

承 認 書

SPECIFICATION FOR APPROVAL

客 戶：
 CUSTOMER: _____
 客 戶 料 號：
 CUST P/N: _____
 淘 软 料 號：
 BESOFTP/N: _____
 產 品 型 號：
 DESC: **Φ 20.5x39-10Ts-0.08x24-10mm-CLB**
 日 期：
 DATE: **2020/11/16**
 版 本：
 Version: **A.0**

擬制 PREPARED BY	審核 CHECKED BY	批准 APPROVED BY	客戶承認 CUSTOMER APPROVE
苏燕平	钱立谋	钱立谋	

深圳淘软电子有限公司

工廠地址：深圳市光明区公明街道李松荫

第一工业区大园路90-6栋9楼TEL:

13824883512/18038013240

SPECIFICATION

產品型號: DESC	$\Phi 20.5 \times 39-10Ts-0.08 \times 24-10mm-CLB$	版本 Rev: A.0	客戶 CUST:	
			Operation frequency:	113kHz-205kHz
			Antenna gain:	0dBi

一、尺寸 DIMENSION:(mm)

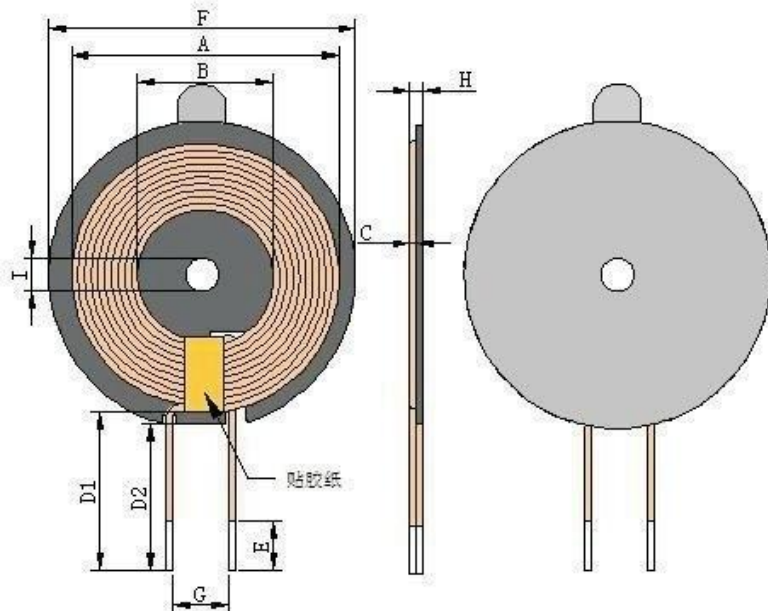

A	39.0±1.5
B	20.5±0.5
C	0.5±0.1
D1	12 ref
D2	10±2
E	3.5±1.5
F	42.5±0.5
G	11.0 ref
H	1.2Max
I	5.3 ref

Note:

1. Coil attached magnetic disc, magnetic disc size 42.5±0.5mm, inner hole 5.3mm, thickness 0.8±0.2mm, L slot.
2. Wrap high temperature adhesive paper with a width of 8mm±0.5 at the coil outlet position.
3. The back of the magnetic disc is affixed with a hand-torn circular diameter of 42.8mm (ref), and the inner hole is 6.0mm (ref).

二、原理图 SCHEMATIC DIAGRAM:



三、绕线参数 Winding Specification:

序号 NO.	端子 TERMINAL	线径 WIRE	圈数 Turns	绕线方向 Winding Direction
1	S F	Hot air cable 0.08*24*2P	10Ts	CCW

四、电气特性 ELECTRICAL CHARACTERISTICS:

温度 TEMPERATURE:25 ±10°C, 湿度 RELATIVE HUMIDITY:65 ±20%

序号 NO.	项目 ITEM	端子 TERMINAL	标准 SPECIFICATION	测试条件 TEST FREQUENCY	测试仪器 TEST EQUIPMENTS
1	IND.	S-F	3.8uH ±20% Individual coil	100KHz/1.0V	LCZ METER 1062B
2	IND.	S-F	6.3uH ±10% Magnetized sheet	100KHz/1.0V	LCZ METER 1062B
3	Q	S-F	70.0(ref) Magnetized sheet	100KHz/1.0V	LCZ METER 1062B
4	DCR	S-F	≤50mΩ		LCZ METER 502B

擬制/日期 PREPARED BY/DATE 苏燕平 2020/11/16	審核/日期 CHECKED BY/DATE 钱立谋 2020/11/16
--	---

SPECIFICATION

產品型號: DESC	Φ20.5x39-10Ts-0.08x24-10mm-CLB	版本 Rev: A.0	客戶 CUST:	
			淘软料号 Fine P/N:	
			客户料号 CUST P/N:	

五、包装 PACKONG:

5.1 包装图片 Packing pictures:

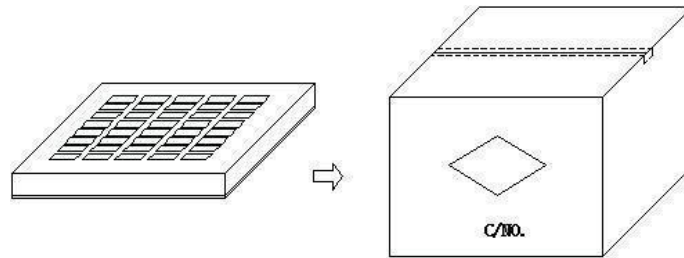

5.2 包装数量及规格 Packing Quantity:

项目 Item	数量 Quantity	材料规格 Material
盒 Box	3500 Pcs	370*265*55mm
箱 Big Carton	1400 Pcs	420*270*310mm

5.3 包装以现有包装盘为参照标准，以实际出货包装为准,如有特需要求可以定制。

The packaging shall be based on the existing packing plate and the actual delivery package shall prevail. If there is any requirement, we can customize it.

六、材料清单 Material list:

序号 number	材料名称 Material name	品名描述 Description	制造商 Manufacturer
1	Enamelled wire 0.07*100 strands	Hot air enamelled wire 0.08*24 strands 2P	
2	Lead-free tin strip	Lead-free tin strip	
3	Glue	201 Glue	
4	High-temperature adhesive tape	8mm wide high temperature adhesive paper	
5	Double-sided tape with holes	With hand tear round diameter 42.8mm(ret) backing	

擬制/日期 PREPARED BY/DATE	審核/日期 CHECKED BY/DATE
苏燕平 2020/11/16	钱立谋 2020/11/16