

TEST REPORT

Report No...... : **KS2205S2141E02**

FCC ID..... : **2A5SKVP211200**

Applicant..... : **Klimtek (Shen Zhen) Tech.Ltd**

Address..... : 5A,Building 1,Tingwei Industrial Park,Xin 'an Street,Bao'an District,Shenzhen

Manufacturer..... : Klimtek (Shen Zhen) Tech.Ltd

Address..... : 5A,Building 1,Tingwei Industrial Park,Xin 'an Street,Bao'an District,Shenzhen

Product Name..... : **Portable Power Station**

Trade Mark..... :  **VIGORPOOL**

Model/Type reference..... : VP21

Listed Model(s)..... : CAPTAIN 1200

Standard..... : **FCC Rules and Regulations Part 15 Subpart C (Section 15.209), ANSI C63.10: 2013**

Date of Receipt..... : May 27, 2022

Date of Test Date..... : May 27, 2022~June 01, 2022

Date of issue..... : June 09, 2022

Test result..... : **Pass**

Prepared by:
(Printed name + Signature) Sky dong



Approved by:
(Printed name + Signature) Neil Wan

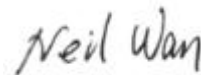

Testing Laboratory Name..... : **KSIGN(Guangdong) Testing Co., Ltd.**

Address..... : West Side of 1/F., Building C, Zone A, Fuyuan New Factory, Jiujiu Industrial Park, Minzhu, Shatou, Shajing, Bao'an District, Shenzhen, Guangdong, People's Republic of China

This test report may be duplicated completely for legal use with the approval of the applicant. It should not be reproduced except in full, without the written approval of our laboratory. The client should not use it to claim product endorsement by KSIGN. The test results in the report only apply to the tested sample. The test report shall be invalid without all the signatures of testing engineers, reviewer and approver. Any objections must be raised to KSIGN within 15 days since the date when the report is received. It will not be taken into consideration beyond this limit. The test report merely correspond to the test sample.

TRF No. Part 15 Subpart C Section 15.207_R1

Add : West Side of 1/F., Building C, Zone A, Fuyuan New Factory, Jiujiu Industrial Park, Minzhu, Shatou, Shajing, Bao'an District, Shenzhen, Guangdong, China

Tel : +(86) 0755-2985 2678 Fax: +(86) 0755-2985 2397 E-mail : info@gdkesign.cn Web: www.gdkesign.com

TABLE OF CONTENTS	Page
1. TEST SUMMARY	3
1.1. TEST STANDARDS	3
1.2. REPORT VERSION	3
1.3. TEST DESCRIPTION	4
1.4. MEASUREMENT UNCERTAINTY	5
1.5. ENVIRONMENTAL CONDITIONS	5
1.6. TEST FACILITY	6
2. GENERAL INFORMATION	7
2.1. GENERAL DESCRIPTION OF EUT	7
2.2. DESCRIPTION OF TEST MODES	8
2.3. MEASUREMENT INSTRUMENTS LIST	9
2.4. TEST SOFTWARE	9
3. TEST ITEM AND RESULTS	10
3.1. ANTENNA REQUIREMENT	10
3.2. CONDUCTED EMISSION	11
3.3. RADIATED SPURIOUS EMISSIONS	14
4. PHOTOGRAPHS OF TEST SETUP	23
5. PHOTOGRAPHS OF EUT CONSTRUCTIONAL	25

1. TEST SUMMARY

1.1. Test Standards

The tests were performed according to following standards:

FCC Rules Part 15 Subpart C: Operation within the bands 115~205 KHz .

ANSI C63.10-2020: American National Standard for Testing Unlicensed Wireless Devices.

1.2. Report version

Revised No.	Date of issue	Description
01	July 19, 2022	Original

1.3. Test Description

EMC Emission			
Test Item	FCC Rules	Result	Test Engineer
Conducted Emission	§15.207	Pass	Cyril Cai
Radiated Emission	§15.209	Pass	Cyril Cai
Antenna Application	§15.203	Pass	Cyril Cai

Note: The measurement uncertainty is not included in the test result.

1.4. Measurement Uncertainty

The data and results referenced in this document are true and accurate. The reader is cautioned that there may be errors within the calibration limits of the equipment and facilities. The measurement uncertainty was calculated for all measurements listed in this test report acc. to TR-100028-01” Electromagnetic compatibility and Radio spectrum Matters (ERM);Uncertainties in the measurement of mobile radio equipment characteristics; Part 1” and TR-100028-02 “Electromagnetic compatibility and Radio spectrum Matters (ERM);Uncertainties in the measurement of mobile radio equipment characteristics; Part 2 “ and is documented in the KSIGN(Guangdong) Testing Co., Ltd. system acc. to DIN EN ISO/IEC 17025. Furthermore, component and process variability of devices similar to that tested may result in additional deviation. The manufacturer has the sole responsibility of continued compliance of the device. Below is the best measurement capability for KSIGN(Guangdong) Testing Co., Ltd.

Test Items	Measurement Uncertainty	Notes
Transmitter power conducted	0.42 dB	(1)
Transmitter power Radiated	2.14 dB	(1)
Conducted spurious emissions 9kHz~40GHz	1.60 dB	(1)
Radiated spurious emissions 9kHz~40GHz	2.20 dB	(1)
Conducted Emissions 9kHz~30MHz	3.20 dB	(1)
Radiated Emissions 30~1000MHz	4.70 dB	(1)
Radiated Emissions 1~18GHz	5.00 dB	(1)
Radiated Emissions 18~40GHz	5.54 dB	(1)
Occupied Bandwidth	2.80 dB	(1)

Note (1): This uncertainty represents an expanded uncertainty expressed at approximately the 95% confidence level using a coverage factor of k=1.96.

1.5. Environmental conditions

During the measurement the environmental conditions were within the listed ranges:

Temperature:	15~35°C
Relative Humidity:	30~60 %
Air Pressure:	950~1050mba

1.6. TEST FACILITY

Address of the report laboratory

KSIGN(Guangdong) Testing Co., Ltd.

West Side of 1/F., Building C, Zone A, Fuyuan New Factory, Jiujiu Industrial Park, Minzhu, Shatou, Shajing, Bao'an District, Shenzhen, Guangdong, People's Republic of China

Laboratory accreditation

The test facility is recognized, certified, or accredited by the following organizations:

CNAS-Lab Code: L13261

KSIGN(Guangdong) Testing Co., Ltd. has been assessed and proved to be in Compliance with CNAS-CL01 Accreditation Criteria for Testing and Calibration Laboratories (identical to ISO/IEC17025: 2017 General Requirements) for the Competence of Testing and Calibration Laboratories.

A2LA-Lab Cert. No.: 5457.01

KSIGN(Guangdong) Testing Co., Ltd. EMC Laboratory has been accredited by A2LA for technical Competence in the field of electrical testing, and proved to be in compliance with ISO/IEC 17025:2017 General Requirements for the Competence of Testing and Calibration Laboratories and any additional program requirements in the identified field of testing.

ISED#: 25693 CAB identifier.: CN0096

KSIGN(Guangdong) Testing Co., Ltd. has been listed by Innovation, Science and Economic Development Canada to perform electromagnetic emission measurement.

FCC-Registration No.: 294912 Designation Number: CN1328

KSIGN(Guangdong) Testing Co., Ltd. EMC Laboratory has been listed on the US Federal Communications Commission list of test facilities recognized to perform electromagnetic emissions measurements.

2. GENERAL INFORMATION

2.1. General Description of EUT

Test Sample Number:	1-1-1(Normal Sample)
Product Name:	Portable Power Station
Trade Mark:	 VIGORPOOL
Model/Type reference:	VP21
Listed Model(s):	CAPTAIN 1200
Model Different:	All models have the same circuit and RF module, except for the different name.
Power supply(Adapter) :	Anderson Input: 12-56V== 12A Max, 400W Max AC Input: 120V~60Hz 10.5A AC Output (x4): 120V~60Hz 10A, Total 1200W (Surge 2400W) AC Parallel Interface (Being Connected): 120V~60Hz, 1200W DC5521 Output (x2): 12V== 3A 36W Max per port, Total 72W Car Output: 12V== 10A, 120W Max (2 x DC5521 Output + Car Output: Total 120W) USB-C Output (x2): 5V== 3A, 9V== 3A, 12V== 3A, 15V== 3A, 20V== 5A 100W Max per port, Total 200W USB-A Output (x2): 5V== 3A, 9V== 2A, 12V== 1.5A 18W Max per port, Total 36W Wireless Output: 10W Max Max. Output Power: 1320W Discharging Temperature: -10-40°C Charging Temperature: 0-40°C
Power supply(Battery) :	DC 25.6V
Hardware version:	VP1200E008C-2150
Software version:	2.0.2

Specification	
Frequency range	115KHz~205KHz
Modulation:	ASK
Antenna type:	Coil Antenna
Antenna gain:	0 dBi

2.2. Description of Test Modes

Operation Frequency List: The EUT has been tested under typical operating condition. The Applicant provides communication tools software to control the EUT for staying in continuous transmitting and receiving mode for testing.

Operation Frequency range: 115KHz~205KHz

Test mode

MODE	TEST MODE DESCRIPTION	
Mode 1	Wireless Charging(5W)	Recorded
Mode 2	Wireless Charging(7.5W)	Recorded
Mode 3	Wireless Charging(10W)	Recorded
Mode 4	Standby	Pre-tested

Note: All test modes were pre-tested, but we only recorded the worst case in this report. Mode 3 is the worst Mode

2.3. Measurement Instruments List

Tonscend JS0806-2 Test system					
Item	Test Equipment	Manufacturer	Model No.	Serial No.	Cal. Until
1	Spectrum Analyzer	R&S	FSV40-N	101798	03/04/2023
2	Wideband Radio Communication Tester	R&S	CMW500	157282	03/04/2023
3	Climate Chamber	Angul	AGNH80L	1903042120	03/04/2023
4	Dual Output DC Power Supply	Agilent	E3646A	MY40009992	03/04/2023

Transmitter spurious emissions & Receiver spurious emissions					
Item	Test Equipment	Manufacturer	Model No.	Serial No.	Cal. Until
1	EMI Test Receiver	R&S	ESR	102525	03/04/2023
2	Spectrum Analyzer	HP	8593E	3831U02087	03/04/2023
3	Ultra-Broadband logarithmic period Antenna	Schwarzbeck	VULB 9163	01230	12/04/2023
4	Loop Antenna	Beijin ZHINAN	ZN30900C	18050	03/05/2023
5	Spectrum Analyzer	R&S	FSV40-N	101798	03/04/2023
7	Pre-Amplifier	Schwarzbeck	BBV 9745	9745#129	03/04/2023
8	Pre-Amplifier	EMCI	EMC051835SE	980662	03/04/2023

Item	Test Equipment	Manufacturer	Model No.	Serial No.	Cal. Until
1	LISN	R&S	ENV432	1326.6105.02	03/04/2023
2	EMI Test Receiver	R&S	ESR	102525	03/04/2023
3	Manual RF Switch	JS TOYO	/	MSW-01/002	03/04/2023

Note:

1)The Cal. Interval was one year.

2)The cable loss has calculated in test result which connection between each test instruments.

Auxiliary test equipment					
Item	Test Equipment	Manufacturer	Model No.	Serial No.	Cal. Until
1	PHONE 1	HUAWEI	P40	/	/

2.4. Test Software

Software name	Model	Version
Conducted emission Measurement Software	EZ-EMC	EMC-Con 3A1.1
Radiated emission Measurement Software	EZ-EMC	FA-03A.2.RE

3. TEST ITEM AND RESULTS

3.1. Antenna requirement

Requirement

FCC CFR Title 47 Part 15 Subpart C Section 15.203:

An intentional radiator shall be designed to ensure that no antenna other than that furnished by the responsible party shall be used with the device. The use of a permanently attached antenna or of an antenna that uses a unique coupling to the intentional radiator, the manufacturer may design the unit so that a broken antenna can be replaced by the user, but the use of a standard antenna jack or electrical connector is prohibited.

Systems operating in the 115KHz~205KHz band that is used exclusively for fixed.

Test Result

The directional gain of the antenna less than 6dBi, please refer to the EUT internal photographs antenna photo.

Note: The antenna is permanently fixed to the EUT

3.2. Conducted Emission

Limit

Conducted Emission Test Limit

Frequency	Maximum RF Line Voltage (dB μ V)	
	Quasi-peak Level	Average Level
150kHz~500kHz	66 ~ 56 *	56 ~ 46 *
500kHz~5MHz	56	46
5MHz~30MHz	60	50

Notes:

- (1) *Decreasing linearly with logarithm of the frequency.
- (2) The lower limit shall apply at the transition frequencies.
- (3) The limit decrease in line with the logarithm of the frequency in the range of 0.15 to 0.50MHz.

Test Configuration

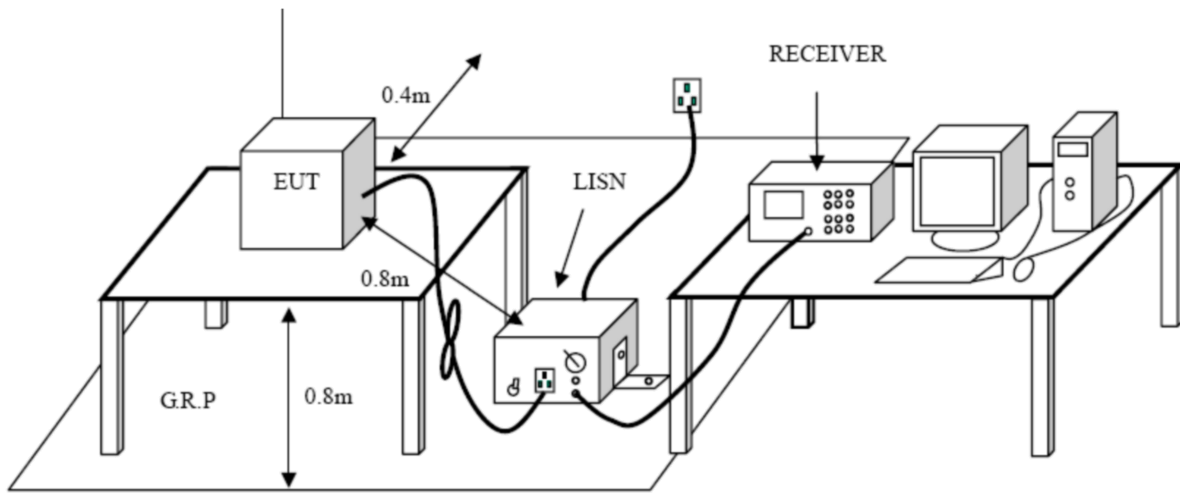

Test Procedure

1. The EUT was setup according to ANSI C63.10:2020 requirements.
2. The EUT was placed on a platform of nominal size, 1 m by 1.5 m, raised 80 cm above the conducting ground plane. The vertical conducting plane was located 40 cm to the rear of the EUT. All other surfaces of EUT were at least 80 cm from any other grounded conducting surface.
3. The EUT and simulators are connected to the main power through a line impedances stabilization network (LISN). The LISN provides a 50ohm /50uH coupling impedance for the measuring equipment. The peripheral devices are also connected to the main power through a LISN. (Please refer to the block diagram of the test setup and photographs)
4. Each current-carrying conductor of the EUT power cord, except the ground (safety) conductor, was individually connected through a LISN to the input power source.
5. The excess length of the power cord between the EUT and the LISN receptacle were folded back and forth at the center of the lead to form a bundle not exceeding 40 cm in length.
6. Conducted Emissions were investigated over the frequency range from 0.15MHz to 30MHz using a receiver bandwidth of 9 kHz.
7. During the above scans, the emissions were maximized by cable manipulation.

Test Mode:

Please refer to the clause 2.3.

Test Results

Pre-scan Mode 1, Mode 2, Mode 3, and found Mode 3 which it is worse case, so only show the test data for worse case (Mode 3) .

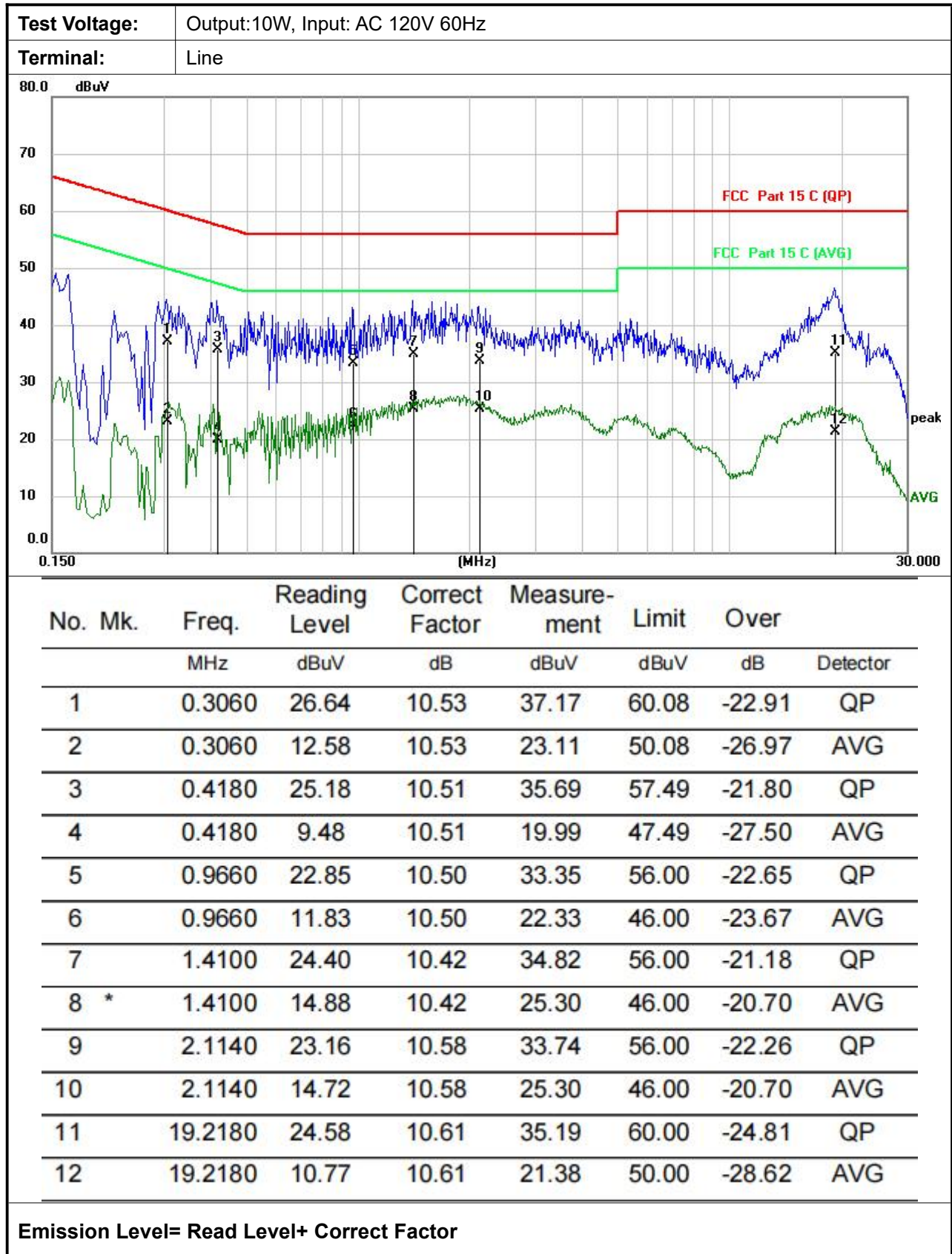

TRF No. Part 15 Subpart C Section 15.207_R1

Add : West Side of 1/F., Building C, Zone A, Fuyuan New Factory, Jiujiu Industrial Park, Minzhu, Shatou, Shajing, Bao'an District, Shenzhen, Guangdong, China

Tel : +(86) 0755-2985 2678 Fax: +(86) 0755-2985 2397 E-mail : info@gksign.cn Web: www.gksign.com

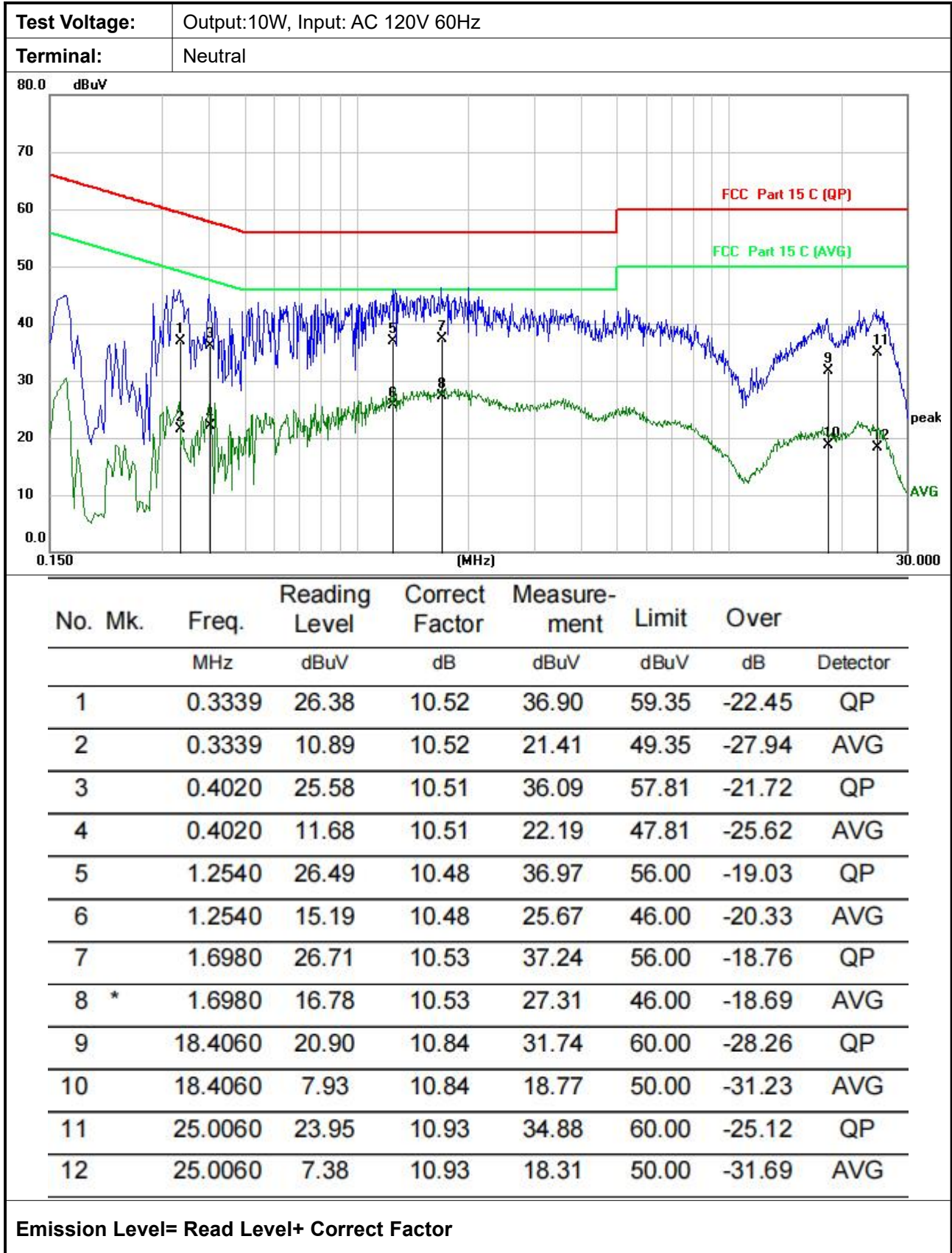

3.3. Radiated Spurious Emissions

LIMIT

FCC CFR Title 47 Part 15 Subpart C Section 15.209(a) and 15.205(a)

20dBc in any 100 kHz bandwidth outside the operating frequency band. In case the emission fall within the restricted band specified on 15.205(a), then the 15.209(a) limit in the table below has to be followed.

15.209(a)

Frequencies (MHz)	Field Strength (microrvolts/meter)	Measurement Distance (meters)
0.009~0.490	2400/F(KHz)	300
0.490~1.705	24000/F(KHz)	30
1.705~30.0	30	30
30~88	100	3
88~216	150	3
216~960	200	3
Above 960	500	3

15.205 Restricted bands of operation:

MHz	MHz	MHz	GHz
0.090-0.110	16.42-16.423	399.9-410	4.5-5.15
¹ 0.495-0.505	16.69475-16.69525	608-614	5.35-5.46
2.1735-2.1905	16.80425-16.80475	960-1240	7.25-7.75
4.125-4.128	25.5-25.67	1300-1427	8.025-8.5
4.17725-4.17775	37.5-38.25	1435-1626.5	9.0-9.2
4.20725-4.20775	73-74.6	1645.5-1646.5	9.3-9.5
6.215-6.218	74.8-75.2	1660-1710	10.6-12.7
6.26775-6.26825	108-121.94	1718.8-1722.2	13.25-13.4
6.31175-6.31225	123-138	2200-2300	14.47-14.5
8.291-8.294	149.9-150.05	2310-2390	15.35-16.2
8.362-8.366	156.52475-156.52525	2483.5-2500	17.7-21.4
8.37625-8.38675	156.7-156.9	2690-2900	22.01-23.12
8.41425-8.41475	162.0125-167.17	3260-3267	23.6-24.0
12.29-12.293	167.72-173.2	3332-3339	31.2-31.8
12.51975-12.52025	240-285	3345.8-3358	36.43-36.5
12.57675-12.57725	322-335.4	3600-4400	(2)
13.36-13.41			

Notes:

- (1).Measurement was performed at an antenna to the closed point of EUT distance of meters.
- (2).Emission level (dBuV/m)=20log Emission level (uV/m).
- (3).Only spurious frequency is permitted to locate within the Restricted Bands specified in provision of 15.205, and the emissions located in restricted bands also comply with 15.209 limit.

(4) .The emission limits shown in the above table are based on measurements employing a CISPR quasi-peak detector except for the frequency bands 9-90 kHz, 110-490 kHz and above 1000 MHz. Radiated emission limits in these three bands are based on measurements employing an average detector.

FREQUENCY RANGE OF RADIATED MEASUREMENT (For unintentional radiators)

Highest frequency generated or Upper frequency of measurement used in the device or on which the device operates or tunes (MHz)	Range (MHz)
Below 1.705	30
1.705 – 108	1000
108 – 500	2000
500 – 1000	5000
Above 1000	5 th harmonic of the highest frequency or 40 GHz, whichever is lower

Spectrum Parameter	Setting
Attenuation	Auto
Start Frequency	1000 MHz
Stop Frequency	10th carrier harmonic
RB / VB (emission in restricted band)	1 MHz / 1 MHz for Peak, 1 MHz / 10Hz for Average

Receiver Parameter	Setting
Attenuation	Auto
Start ~ Stop Frequency	9kHz~150kHz / RB 200Hz for QP
Start ~ Stop Frequency	150kHz~30MHz / RB 9kHz for QP
Start ~ Stop Frequency	30MHz~1000MHz / RB 120kHz for QP

Test Configuration

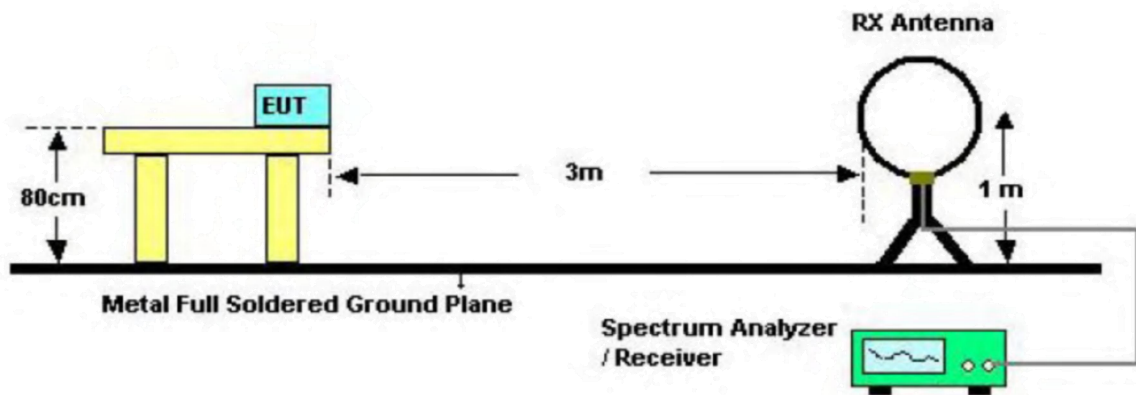

Below 30MHz Test Setup

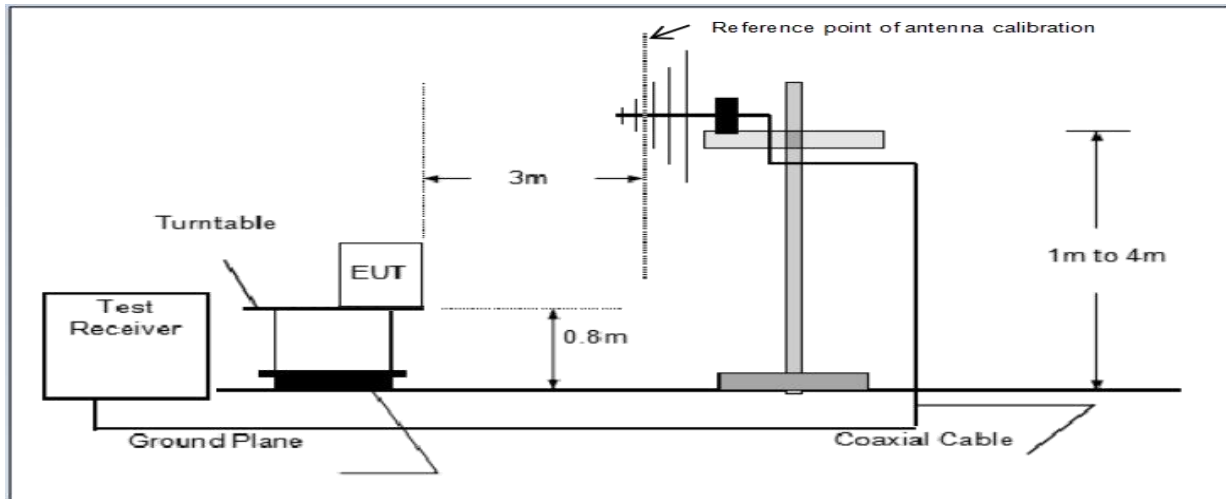

Below 1GHz Test Setup

Test Procedure

1. The EUT was setup and tested according to ANSI C63.10:2020
2. The EUT is placed on a turn table which is 0.8 meter above ground for below 1 GHz, and 1.5 m for above 1 GHz. The turn table is rotated 360 degrees to determine the position of the maximum emission level.
3. The EUT was set 3 meters from the receiving antenna, which was mounted on the top of a variable height antenna tower.
4. For each suspected emission, the EUT was arranged to its worst case and then tune the Antenna tower (from 1 m to 4 m) and turntable (from 0 degree to 360 degrees) to find the maximum reading. A pre-amp and a high pass filter are used for the test in order to get better signal level to comply with the guidelines.
5. Set to the maximum power setting and enable the EUT transmit continuously.
6. Use the following spectrum analyzer settings
 - (1) Span shall wide enough to fully capture the emission being measured;
 - (2) Below 1 GHz:
 RBW=120 kHz, VBW=300 kHz, Sweep=auto, Detector function=peak, Trace=max hold;
 If the emission level of the EUT measured by the peak detector is 3 dB lower than the applicable limit, the peak emission level will be reported. Otherwise, the emission measurement will be repeated using the quasi-peak detector and reported.
 - (3) From 1 GHz to 10th harmonic:
 RBW=1MHz, VBW=3MHz Peak detector for Peak value.
 RBW=1MHz, VBW=10Hz Peak detector for Average value.

TEST MODE:

Please refer to the clause 2.3

TEST RESULTS

Passed **Not Applicable**

9 KHz~30 MHz and 30MHz~1GHz

From 9 KHz~30 MHz and 30MHz~1GHz: Conclusion: PASS

Note:

- 1) Final level = Reading level + Correct Factor
 Correct Factor=Antenna Factor + Cable Loss -Preamplifier Factor

For 9 KHz-30MHz

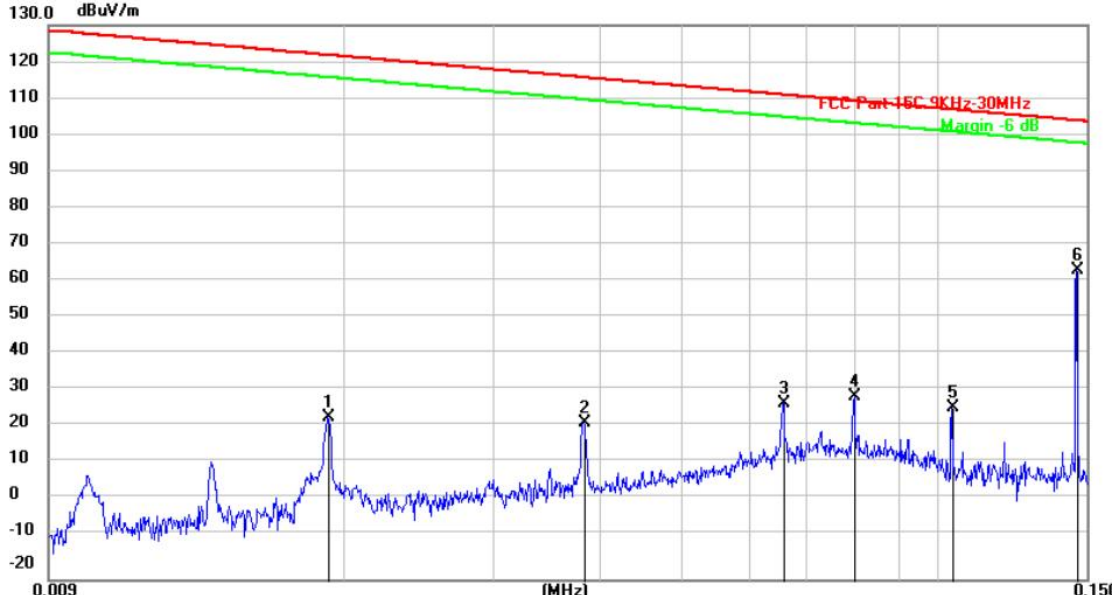
Test Voltage:	Output: 10W, Input: AC 120V 60Hz						
Ant. Pol.	Horizontal						
Test Mode:	Mode 3 worse case						
							
No. Mk.	Freq.	Reading Level	Correct Factor	Measure-ment	Limit	Over	Detector
	MHz	(dBuV)	(dB/m)	(dBuV/m)	(dBuV/m)	(dB)	
1	0.0192	32.93	-9.05	23.88	121.94	-98.06	peak
2	0.0384	31.64	-8.91	22.73	115.92	-93.19	peak
3	0.0659	37.10	-9.28	27.82	111.23	-83.41	peak
4	0.0799	38.88	-9.15	29.73	109.55	-79.82	peak
5	0.1041	35.55	-8.90	26.65	107.26	-80.61	peak
6 *	0.1459	73.27	-9.41	63.86	104.32	-40.46	peak
Emission Level= Read Level+ Correct Factor							

Test Voltage:	Output: 10W, Input: AC 120V 60Hz
Ant. Pol.	Horizontal
Test Mode:	Mode 3 worse case

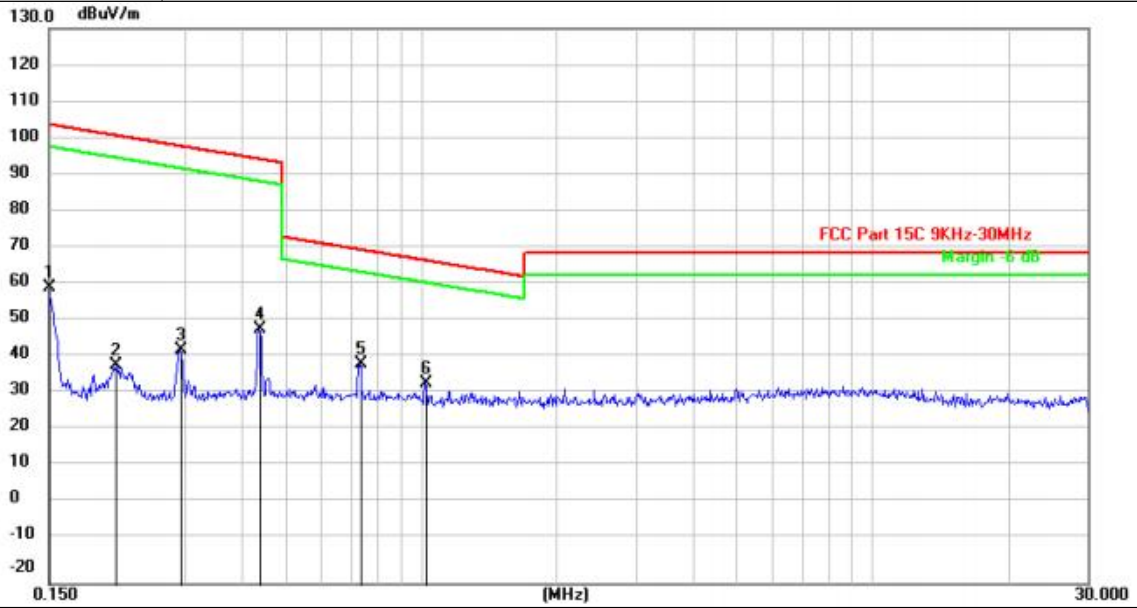

No.	Mk.	Freq. MHz	Reading Level (dBuV)	Correct Factor (dB/m)	Measure- ment (dBuV/m)	Limit (dBuV/m)	Over (dB)	Detector
1		0.1500	69.50	-9.33	60.17	104.08	-43.91	peak
2		0.2107	48.52	-9.31	39.21	101.13	-61.92	peak
3		0.2934	52.31	-9.29	43.02	98.25	-55.23	peak
4		0.4395	57.87	-9.24	48.63	94.74	-46.11	peak
5	*	0.7316	48.69	-9.16	39.53	70.32	-30.79	peak
6		1.0249	43.21	-9.11	34.10	67.39	-33.29	peak

Emission Level= Read Level+ Correct Factor

Test Voltage:	Output: 10W, Input: AC 120V 60Hz
Ant. Pol.	Vertical
Test Mode:	Mode 3 worse case

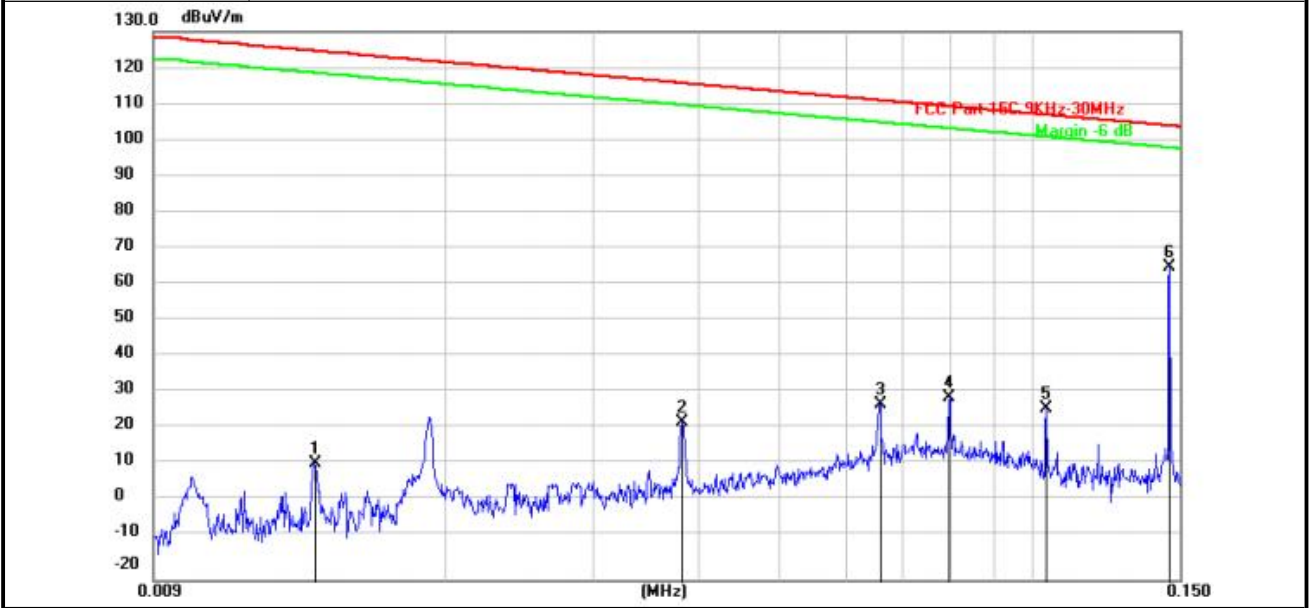

No.	Mk.	Freq. MHz	Reading Level (dBuV)	Correct Factor (dB/m)	Measure- ment (dBuV/m)	Limit (dBuV/m)	Over (dB)	Detector
1		0.0140	21.08	-9.08	12.00	124.68	-112.68	peak
2		0.0383	32.15	-8.92	23.23	115.94	-92.71	peak
3		0.0659	37.60	-9.28	28.32	111.23	-82.91	peak
4		0.0796	39.39	-9.16	30.23	109.59	-79.36	peak
5		0.1039	36.05	-8.90	27.15	107.27	-80.12	peak
6	*	0.1457	75.26	-9.40	65.86	104.34	-38.48	peak

Emission Level= Read Level+ Correct Factor

Test Voltage:	Output: 10W, Input: AC 120V 60Hz
Ant. Pol.	Vertical
Test Mode:	Mode 3 worse case

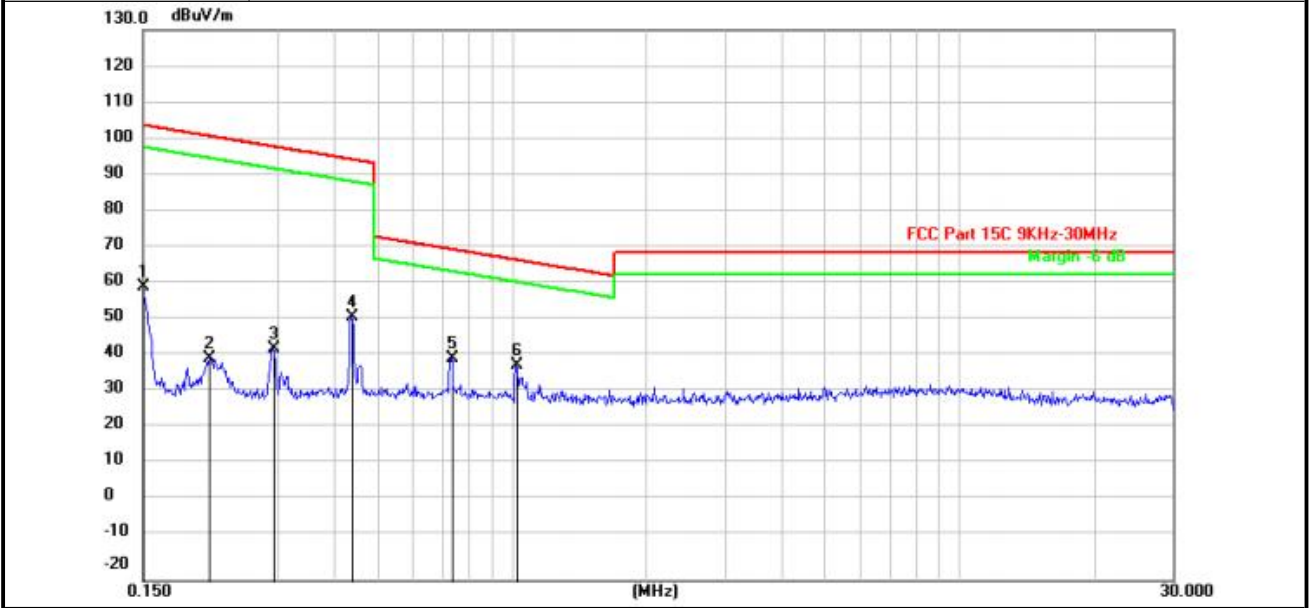

No.	Mk.	Freq. MHz	Reading Level (dBuV)	Correct Factor (dB/m)	Measure- ment (dBuV/m)	Limit (dBuV/m)	Over (dB)	Detector
1		0.1500	69.50	-9.33	60.17	104.08	-43.91	peak
2		0.2106	50.02	-9.31	40.71	101.13	-60.42	peak
3		0.2933	52.31	-9.29	43.02	98.26	-55.24	peak
4		0.4395	60.87	-9.24	51.63	94.74	-43.11	peak
5		0.7316	49.69	-9.16	40.53	70.32	-29.79	peak
6	*	1.0245	47.71	-9.11	38.60	67.39	-28.79	peak

Emission Level= Read Level+ Correct Factor

30MHz-1GHz

Test Voltage:	Output: 10W, Input: AC 120V 60Hz
Ant. Pol.	Horizontal
Test Mode:	Mode 3 worse case



No.	Mk.	Freq. MHz	Reading Level (dBuV)	Correct Factor (dB/m)	Measure- ment (dBuV/m)	Limit (dBuV/m)	Over (dB)	Detector
1	!	214.1385	56.56	-17.37	39.19	43.50	-4.31	QP
2	*	263.4491	58.93	-15.49	43.44	46.00	-2.56	QP
3		340.9012	44.40	-12.92	31.48	46.00	-14.52	QP
4	!	399.4502	50.99	-10.93	40.06	46.00	-5.94	QP
5		440.6596	44.04	-10.43	33.61	46.00	-12.39	QP
6		483.5702	37.88	-10.06	27.82	46.00	-18.18	QP

Note

- 1). Level (dBuV/m) = Reading (dBuV) + Factor (dB/m)
- 2). Factor (dB/m) = Antenna Factor (dB/m) + Cable loss (dB) - Pre Amplifier gain (dB)
- 3). Margin (dB) = Limit (dBuV/m) - Level (dBuV/m)

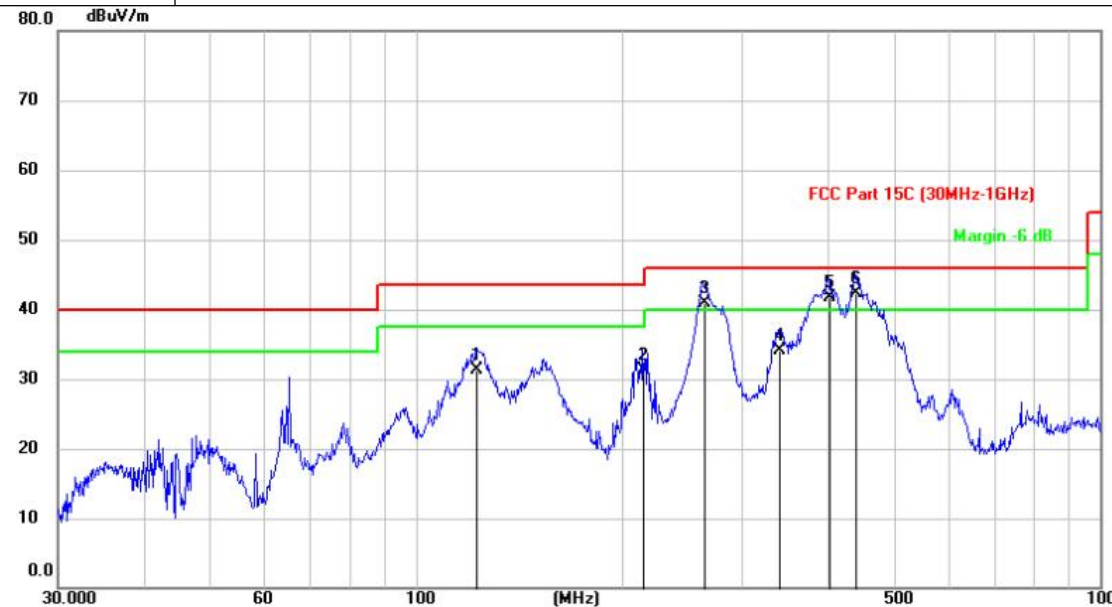
Test Voltage:	Output: 10W, Input: AC 120V 60Hz							
Ant. Pol.	Vertical							
Test Mode:	Mode 3 worse case							
								
No.	Mk.	Freq.	Reading	Correct	Measurement	Limit	Over	
		MHz	(dBuV)	(dB/m)	(dBuV/m)	(dBuV/m)	(dB)	Detector
1		122.5758	51.07	-19.73	31.34	43.50	-12.16	QP
2		215.1923	48.56	-17.32	31.24	43.50	-12.26	QP
3	!	263.7265	56.37	-15.48	40.89	46.00	-5.11	QP
4		340.6622	46.99	-12.94	34.05	46.00	-11.95	QP
5	!	400.5723	52.71	-10.91	41.80	46.00	-4.20	QP
6	*	438.9589	52.66	-10.45	42.21	46.00	-3.79	QP
Note								
1).Level (dBuV/m)= Reading (dBuV)+ Factor (dB/m)								
2). Factor(dB/m)=Antenna Factor (dB/m) + Cable loss (dB) - Pre Amplifier gain (dB)								
3). Margin(dB) = Limit (dBuV/m) - Level (dBuV/m)								

4.PHOTOGRAPHS OF TEST SETUP

CONDUCTED EMISSION TEST SETUP

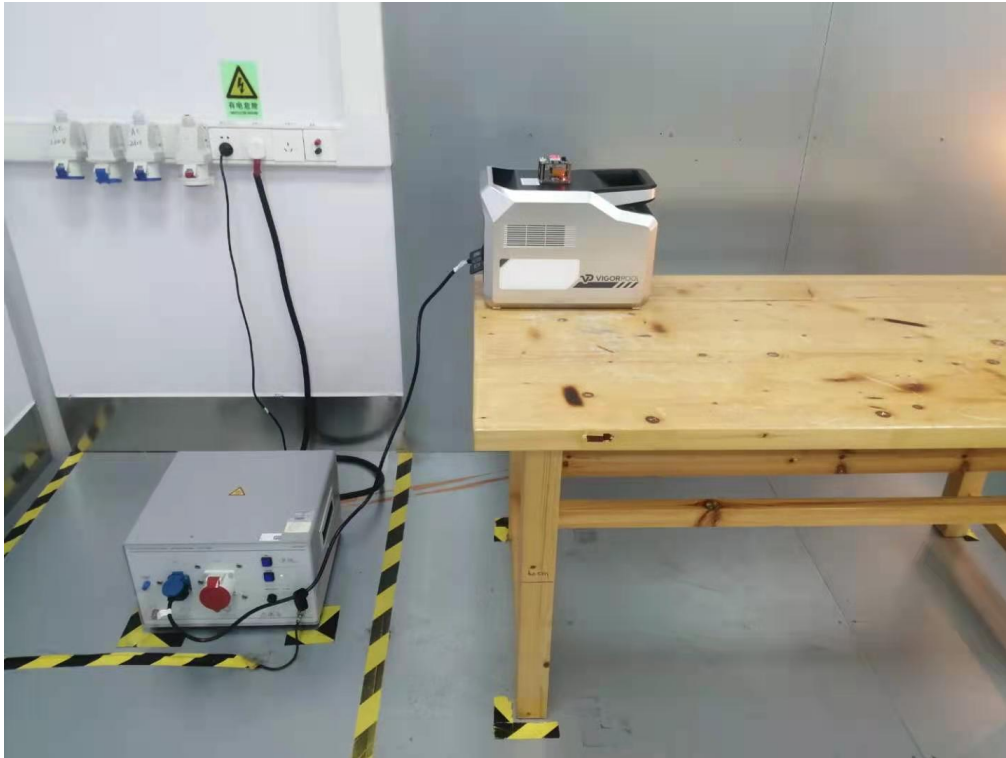

9KHz-30MHz



30MHz-1GHz

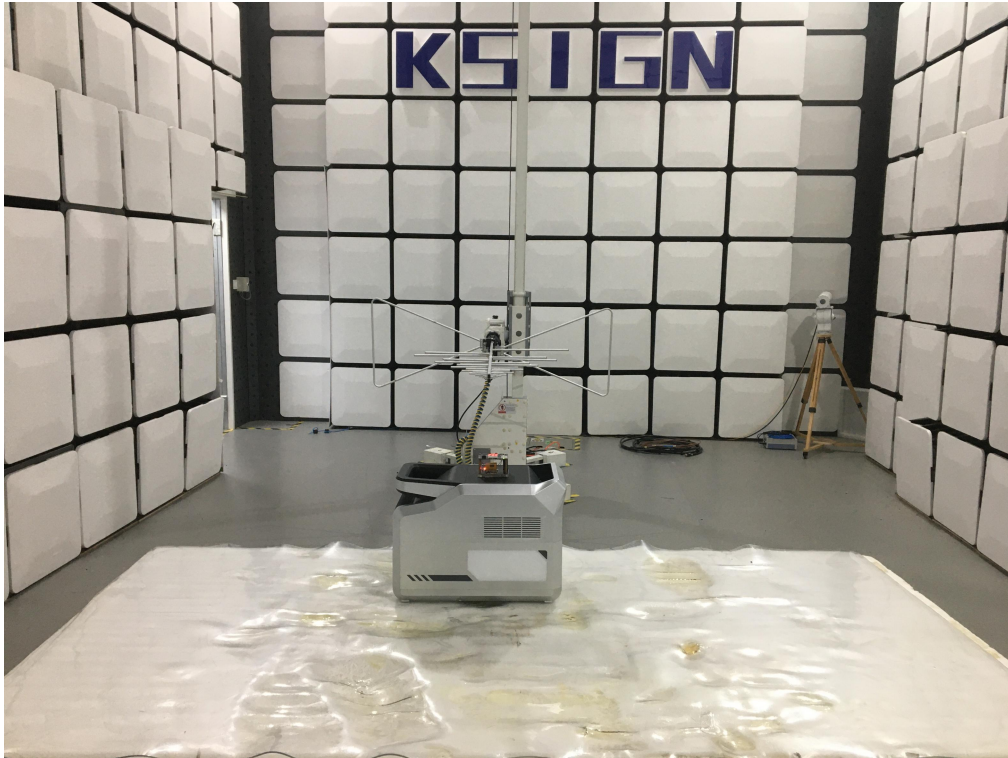

5. PHOTOGRAPHS OF EUT CONSTRUCTIONAL

Reference to the test report No.: KS2205S2141E01

--THE END--