

FCC RADIO TEST REPORT

Applicant..... : Abbingdon Global Limited
Address..... : 79 SCARISBRICK NEW ROAD SOUTHPORT ENGLAND PR&8 6LJ
Manufacturer..... : Abbingdon Global Limited
Address..... : 79 SCARISBRICK NEW ROAD SOUTHPORT ENGLAND PR&8 6LJ
Factory..... : Dongguan Kaiyun Technology Co., Ltd.
Address..... : No. 1 Wenming Street, Jinhe, Zhangmutou, Dongguan, Guangdong,
523628, China
Product Name..... : Bluetooth decoder
Brand Name..... : iFi
Model No. : ZEN Blue V2
FCC ID..... : 2A5QJZENBLUEV2
Measurement Standard..... : 47 CFR FCC Part 15, Subpart C (Section 15.247)
Receipt Date of Samples..... : March 11, 2022
Date of Tested..... : March 11, 2022 to April 15, 2022
Date of Report..... : April 18, 2022

This report shows that above equipment is technically compliant with the requirements of the standards above. All test results in this report apply only to the tested sample(s). Without prior written approval of Dongguan Nore Testing Center Co., Ltd, this report shall not be reproduced except in full.

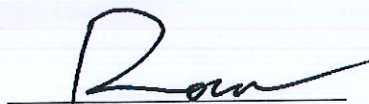

Prepared by

Rose Hu / Project Engineer



Approved by

Iori Fan / Authorized Signatory

Table of Contents

| | |
|---|----|
| 1. Summary of Test Result | 4 |
| 2. General Description of EUT | 5 |
| 3. Test Channels and Modes Detail..... | 8 |
| 4. Configuration of EUT | 8 |
| 5. Modification of EUT | 8 |
| 6. Description of Support Device | 9 |
| 7. Test Facility and Location | 10 |
| 8. Applicable Standards and References | 11 |
| 9. Deviations and Abnormalities from Standard Conditions | 11 |
| 10. Test Conditions | 12 |
| 11. Measurement Uncertainty | 13 |
| 12. Sample Calculations | 14 |
| 13. Test Items and Results | 15 |
| 13.1 Conducted Emissions Measurement..... | 15 |
| 13.2 Radiated Spurious Emissions and Restricted Bands Measurement | 19 |
| 13.3 Channel Separation test..... | 26 |
| 13.4 20dB Bandwidth | 29 |
| 13.5 Hopping Channel Number | 33 |
| 13.6 Time of Occupancy (Dwell Time)..... | 36 |
| 13.7 Maximum Peak Output Power | 38 |
| 13.8 Band Edge Conducted Spurious Emission Measurement..... | 42 |
| 13.9 Antenna Requirement | 49 |
| 14. Test Equipment List..... | 50 |

1. Summary of Test Result

| FCC Rules | Description of Test | Result | Remarks |
|---------------------------------|-----------------------------------|--------|---------|
| §15.247(a)(1) | Channel Separation test | PASS | --- |
| §15.247(a)(1) | 20dB Bandwidth | PASS | --- |
| §15.247(a)(1)(iii) | Hopping Channel Number | PASS | --- |
| §15.247(a)(1)(iii) | Time of Occupancy (Dwell Time) | PASS | --- |
| §15.247(b) | Max Peak output Power test | PASS | --- |
| §15.247(d) | Band edge test | PASS | --- |
| §15.207 (a) | AC Power Conducted Emission | PASS | --- |
| §15.247(d), §15.209, §15.205 | Radiated Emission | PASS | --- |
| §15.203 | Antenna Requirement | PASS | --- |
| §15.247(d) | Conducted Spurious Emission | PASS | --- |

2. General Description of EUT

| Product Information | |
|-------------------------|--|
| Product Name: | Bluetooth decoder |
| Main Model Name: | ZEN Blue V2 |
| Additional Model Name: | N/A |
| Model Difference: | N/A |
| S/N: | 2203-0853 |
| Brand Name | iFi |
| Hardware Version: | V01 |
| Software Version: | V01 |
| Rating: | DC 5V come from DC port |
| Typical Arrangement: | Table-top |
| I/O Port: | RCA output port*1, DC 5V port *1 |
| Accessories Information | |
| Adapter: | Manufacturer: Powertron Technology Co., Ltd. M/N: LN-0531 Input: AC100-240V 50/60Hz, 0.5A Output: DC 5V 2.5A |
| Cable: | DC line: 1.95m unshielded, with a core |
| Other: | N/A |
| Additional Information | |
| Note: | N/A |
| Remark: | All the information above are provided by the manufacturer. More detailed feature of the EUT please refers to the user manual. |

| Technical Specification | |
|--|--|
| Bluetooth Version: | V5.0 |
| Frequency Range: | 2402-2480MHz |
| Modulation Type: | GFSK, $\pi/4$ -DQPSK, 8DPSK |
| Number of Channel: | 79 (refer to following channel list for details) |
| Channel Space: | 1MHz |
| Antenna Type: | Integral antenna |
| Antenna Gain: | 3.0dBi |
| Note: The EUT does not support Bluetooth Low Energy feature. | |

| Channel List | | | | | | | |
|--------------|-----------------|---------|-----------------|---------|-----------------|---------|-----------------|
| Channel | Frequency (MHz) | Channel | Frequency (MHz) | Channel | Frequency (MHz) | Channel | Frequency (MHz) |
| 1 | 2402 | 21 | 2422 | 41 | 2442 | 61 | 2462 |
| 2 | 2403 | 22 | 2423 | 42 | 2443 | 62 | 2463 |
| 3 | 2404 | 23 | 2424 | 43 | 2444 | 63 | 2464 |
| 4 | 2405 | 24 | 2425 | 44 | 2445 | 64 | 2465 |
| 5 | 2406 | 25 | 2426 | 45 | 2446 | 65 | 2466 |
| 6 | 2407 | 26 | 2427 | 46 | 2447 | 66 | 2467 |
| 7 | 2408 | 27 | 2428 | 47 | 2448 | 67 | 2468 |
| 8 | 2409 | 28 | 2429 | 48 | 2449 | 68 | 2469 |
| 9 | 2410 | 29 | 2430 | 49 | 2450 | 69 | 2470 |
| 10 | 2411 | 30 | 2431 | 50 | 2451 | 70 | 2471 |
| 11 | 2412 | 31 | 2432 | 51 | 2452 | 71 | 2472 |
| 12 | 2413 | 32 | 2433 | 52 | 2453 | 72 | 2473 |
| 13 | 2414 | 33 | 2434 | 53 | 2454 | 73 | 2474 |
| 14 | 2415 | 34 | 2435 | 54 | 2455 | 74 | 2475 |
| 15 | 2416 | 35 | 2436 | 55 | 2456 | 75 | 2476 |
| 16 | 2417 | 36 | 2437 | 56 | 2457 | 76 | 2477 |
| 17 | 2418 | 37 | 2438 | 57 | 2458 | 77 | 2478 |
| 18 | 2419 | 38 | 2439 | 58 | 2459 | 78 | 2479 |
| 19 | 2420 | 39 | 2440 | 59 | 2460 | 79 | 2480 |
| 20 | 2421 | 40 | 2441 | 60 | 2461 | --- | --- |

3. Test Channels and Modes Detail

| No. | Mode | Channel | Frequency (MHz) | Modulation |
|-----|---------|---------|-----------------|-------------------------------|
| 1 | TX | Hopping | 2402-2480 | GFSK / $\pi/4$ -DQPSK / 8DPSK |
| 2 | TX | Low | 2402 | GFSK / $\pi/4$ -DQPSK / 8DPSK |
| 3 | TX | Mid | 2441 | GFSK / $\pi/4$ -DQPSK / 8DPSK |
| 4 | TX | High | 2480 | GFSK / $\pi/4$ -DQPSK / 8DPSK |
| 5 | BT Link | --- | --- | --- |

Note: TX mode means that the EUT was programmed to be in continuously transmitting mode.

4. Configuration of EUT

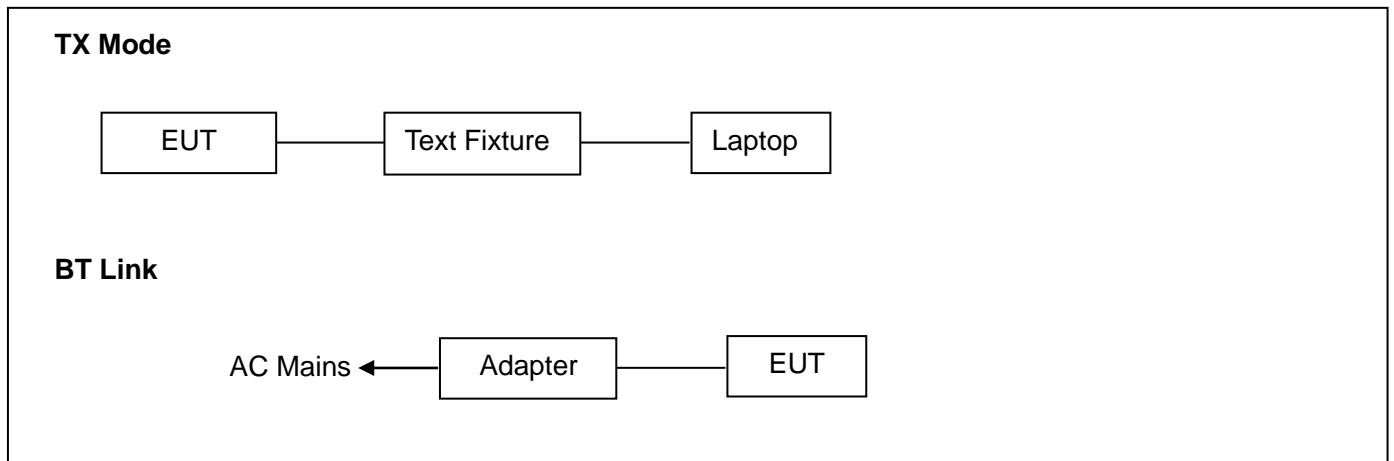

5. Modification of EUT

No modifications are made to the EUT during all test items.

6. Description of Support Device

The EUT has been tested as an independent unit together with other necessary accessories or support units. The following support units or accessories were used to form a representative test configuration during the tests.

| No. | Equipment | Brand | M/N | S/N | Cable Specification | Remarks |
|-----|-------------------------------|-----------------|-----------------|------------------|---|--|
| 1. | Laptop | R720-15 1KBN | PF0Z35FH | | Power cord, 1.8m, unshielded | Provided by the Lab. |
| 2. | Power supply of the Laptop | Delta | ADL135ND C3A | N/A | AC Line: 1.10m unshielded DC Line: 1.15m unshielded with a core | I/P: AC 100-240V 50-60Hz, 1.5A O/P: DC 20V 6.75A Provided by the Lab. |
| 3. | Laptop | DELL | VOSTR0340 0 | H3K 2XA 01 | Power cord, 1.8m, unshielded | Provided by the Lab. |
| 4. | Power supply of the Laptop | DELL | HA45NM14 0 | N/A | AC Line: 1.10m unshielded DC Line: 1.15m unshielded with a core | I/P: AC 100-240V 50-60Hz, 1.3A O/P: DC 19.5V 2.31A 45W |
| 5. | Test fixture | --- | --- | --- | ---- | Provided by manufacturer |

| No. | Test Software | Modulation | Power Setting |
|-----|-----------------|----------------|---------------|
| 1. | BlueSuite 3.2.0 | GFSK | 2,5,1 |
| 2. | | $\pi/4$ -DQPSK | 2,5,1 |
| 3. | | 8DPSK | 2,5,1 |

7. Test Facility and Location

| | | |
|-----------------------------------|---|---|
| Test Site | : | Dongguan Nore Testing Center Co., Ltd. (Dongguan NTC Co., Ltd.) |
| Accreditations and Authorizations | : | <p>The Laboratory has been assessed and proved to be in compliance with CNAS/CL01 Listed by CNAS, August 13, 2018 The Certificate Registration Number is L5795. The Certificate is valid until August 13, 2024</p> <p>The Laboratory has been assessed and proved to be in compliance with ISO17025 Listed by A2LA, November 01, 2017 The Certificate Registration Number is 4429.01 The Certificate is valid until December 31, 2023</p> <p>Listed by FCC, November 06, 2017 Test Firm Registration Number: 907417</p> <p>Listed by Industry Canada, June 08, 2017 The Certificate Registration Number. Is 46405-9743A</p> |
| Test Site Location | : | Building D, Gaosheng Science and Technology Park, Hongtu Road, Nancheng District, Dongguan City, Guangdong Province, China |

8. Applicable Standards and References

According to the specifications of the manufacturer, the EUT must comply with the requirements of the following standards:

Test Standards:

47 CFR Part 15, Subpart C, 15.247

ANSI C63.10-2013

References Test Guidance:

DTS KDB 558074 D01 15.247 Meas Guidance v05r02

Remark:

The EUT has also been tested and complied with the requirements of FCC Part 15, Subpart B, recorded in a separate test report.

9. Deviations and Abnormalities from Standard Conditions

No additions, deviations and exclusions from the standard.

10. Test Conditions

| No. | Test Item | Test Mode | Test Voltage | Tested by | Remarks |
|-----|-----------------------------------|-----------|-------------------------------|-----------|-----------------------|
| 1. | Channel Separation test | 1 | AC 120V 60Hz | Sean | See note ¹ |
| 2. | 20dB Bandwidth | 2-4 | AC 120V 60Hz | Sean | See note ¹ |
| 3. | Hopping Channel Number | 1 | AC 120V 60Hz | Sean | See note ¹ |
| 4. | Time of Occupancy (Dwell Time) | 1 | AC 120V 60Hz | Sean | See note ¹ |
| 5. | Max Peak output Power test | 2-4 | AC 120V 60Hz | Sean | See note ¹ |
| 6. | Band edge test | 1-4 | AC 120V 60Hz | Sean | See note ¹ |
| 7. | AC Power Conducted Emission | 5 | AC 120V 60Hz, AC 240V 60Hz | Sean | See note ¹ |
| 8. | Radiated Emission | 1-4 | AC 120V 60Hz, AC 240V 60Hz | Sean | See note ¹ |
| 9. | Antenna Requirement | --- | --- | --- | --- |
| 10. | Conducted Spurious Emission | 1-4 | AC 120V 60Hz | Sean | See note ¹ |

Note:

1. The testing climatic conditions for temperature, humidity, and atmospheric pressure are within: 15~35°C, 30~70%, 86~106kPa.
2. For the test voltage AC 120V 60Hz, AC 240V 60Hz was come from adapter, only the worst case was recorded in the test report.

11. Measurement Uncertainty

| No. | Test Item | Frequency | Uncertainty | Remarks |
|-----|----------------------------|----------------|-------------------------------|---------|
| 1. | Conducted Emission | 150KHz ~ 30MHz | ±2.52 dB | --- |
| 2. | Radiated Emission | 9kHz ~ 30MHz | ±2.60 dB | |
| | | 30MHz ~ 1GHz | ±4.68 dB | --- |
| | | 1GHz ~ 18GHz | ±5.14 dB | --- |
| | | 18GHz ~ 40GHz | ±5.14 dB | |
| 3. | RF Conducted Test | 10Hz ~ 40GHz | ±1.06 dB | --- |
| 4. | Occupied Channel Bandwidth | --- | ±1.42 x10 ⁻⁴ % MHz | --- |

Note:

1. This uncertainty represents an expanded uncertainty expressed at approximately the 95% confidence level using a coverage factor of k=2.
2. The measurement uncertainty levels above are estimated and calculated according to CISPR 16-4-2.
3. The conformity assessment statement in this report is based solely on the test results, measurement uncertainty is excluded.

12. Sample Calculations

| Conducted Emission | | | | | | |
|--------------------|----------------------|---------------------|--------------------|--------------|-----------|----------|
| Freq. (MHz) | Reading Level (dBuV) | Correct Factor (dB) | Measurement (dBuV) | Limit (dBuV) | Over (dB) | Detector |
| 0.2100 | 33.90 | 10.60 | 44.50 | 63.21 | -18.71 | QP |

Where,

Freq. = Emission frequency in MHz
 Reading Level = Spectrum Analyzer/Receiver Reading
 Corrector Factor = Insertion loss of LISN + Cable Loss + RF Switching Unit attenuation
 Measurement = Reading + Corrector Factor
 Limit = Limit stated in standard
 Margin = Measurement - Limit
 Detector = Reading for Quasi-Peak / Average / Peak

| Radiated Spurious Emissions and Restricted Bands | | | | | | |
|--|----------------------|-----------------------|----------------------|----------------|-----------|----------|
| Freq. (MHz) | Reading Level (dBuV) | Correct Factor (dB/m) | Measurement (dBuV/m) | Limit (dBuV/m) | Over (dB) | Detector |
| 35.8200 | 45.09 | -8.91 | 36.18 | 40.00 | -3.82 | QP |

Where,

Freq. = Emission frequency in MHz
 Reading Level = Spectrum Analyzer/Receiver Reading
 Corrector Factor = Antenna Factor + Cable Loss - Pre-amplifier
 Measurement = Reading + Corrector Factor
 Limit = Limit stated in standard
 Over = Margin, which calculated by Measurement - Limit
 Detector = Reading for Quasi-Peak / Average / Peak

Note: For all conducted test items, the spectrum analyzer offset or transducer is derived from RF cable loss and attenuator factor. The offset or transducer is equal to the RF cable loss plus attenuator factor.

13. Test Items and Results

13.1 Conducted Emissions Measurement

LIMITS

According to the requirements of FCC PART 15.207, the limits are as follows:

| Frequency (MHz) | Quasi-peak | Average |
|-----------------|------------|----------|
| 0.15 to 0.5 | 66 to 56 | 56 to 46 |
| 0.5 to 5 | 56 | 46 |
| 5 to 30 | 60 | 50 |

Note: 1. If the limits for the average detector are met when using the quasi-peak detector, then the limits for the measurements with the average detector are considered to be met.
 2. The lower limit shall apply at the transition frequencies.
 3. The limit decreases linearly with the logarithm of the frequency in the range 0.15 MHz to 0.5MHz.

BLOCK DIAGRAM OF TEST SETUP

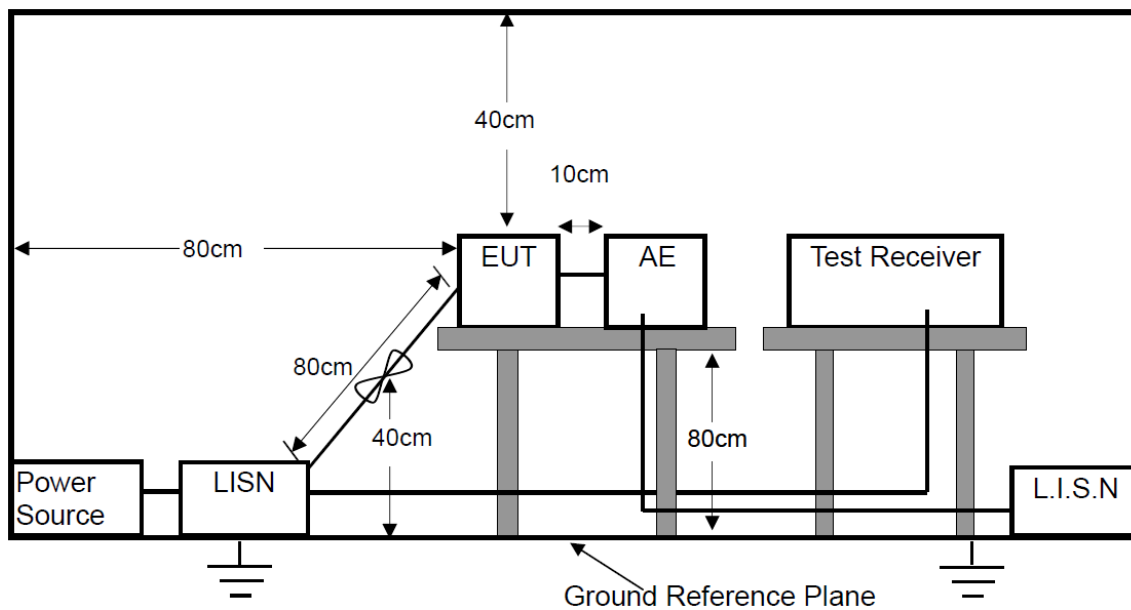

TEST PROCEDURES

- a. The EUT was placed on a wooden table 0.8m height from the metal ground plan and 0.4m from the conducting wall of the shielding room and it was kept at 0.8m from any other grounded conducting surface.
- b. All I/O cables and support devices were positioned as per ANSI C63.10.
- c. Connect mains power port of the EUT to a line impedance stabilization network (LISN).
- d. Connect all support devices to the other LISN and AAN, if needed.
- e. Scan the frequency range from 150KHz to 30MHz at both sides of AC line for maximum conducted interference checking and record the test data.

TEST RESULTS

PASS

Please refer to the following pages of the worst case.

| | |
|----------------------------------|-------------------------------|
| M/N: ZEN Blue V2 | Testing Voltage: AC 240V/60Hz |
| Phase: L1 | Detector: QP & AVG |
| Test Mode: 5 (8DPSK Low channel) | |

Conducted Emission Measurement

Date: 2022/3/12

Time: 15:19:09

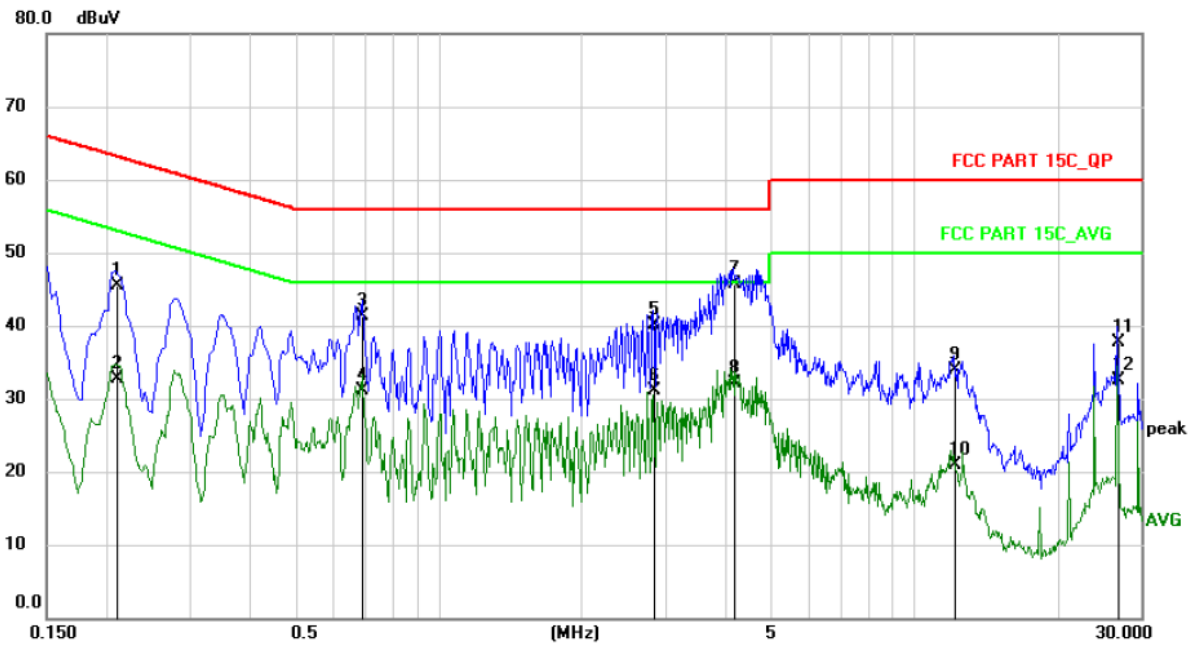

| No. Mk. | Freq. MHz | Reading Level dBuV | Correct Factor dB | Measurement dBuV | Limit dBuV | Over dB | Detector | Comment |
|---------|-----------|--------------------|-------------------|------------------|------------|---------|----------|---------|
| 1 | 0.2100 | 34.90 | 10.60 | 45.50 | 63.21 | -17.71 | QP | |
| 2 | 0.2100 | 22.10 | 10.60 | 32.70 | 53.21 | -20.51 | AVG | |
| 3 | 0.6900 | 30.74 | 10.66 | 41.40 | 56.00 | -14.60 | QP | |
| 4 | 0.6900 | 20.54 | 10.66 | 31.20 | 46.00 | -14.80 | AVG | |
| 5 | 2.8260 | 29.39 | 10.71 | 40.10 | 56.00 | -15.90 | QP | |
| 6 | 2.8260 | 20.49 | 10.71 | 31.20 | 46.00 | -14.80 | AVG | |
| 7 * | 4.1577 | 35.09 | 10.71 | 45.80 | 56.00 | -10.20 | QP | |
| 8 | 4.1577 | 21.49 | 10.71 | 32.20 | 46.00 | -13.80 | AVG | |
| 9 | 12.1539 | 23.16 | 10.74 | 33.90 | 60.00 | -26.10 | QP | |
| 10 | 12.1539 | 10.16 | 10.74 | 20.90 | 50.00 | -29.10 | AVG | |
| 11 | 26.8140 | 27.01 | 10.79 | 37.80 | 60.00 | -22.20 | QP | |
| 12 | 26.8140 | 21.71 | 10.79 | 32.50 | 50.00 | -17.50 | AVG | |

| | |
|----------------------------------|-------------------------------|
| M/N: ZEN Blue V2 | Testing Voltage: AC 240V/60Hz |
| Phase: N | Detector: QP & AVG |
| Test Mode: 5 (8DPSK Low channel) | |

Conducted Emission Measurement

Date: 2022/3/12

Time: 15:24:38

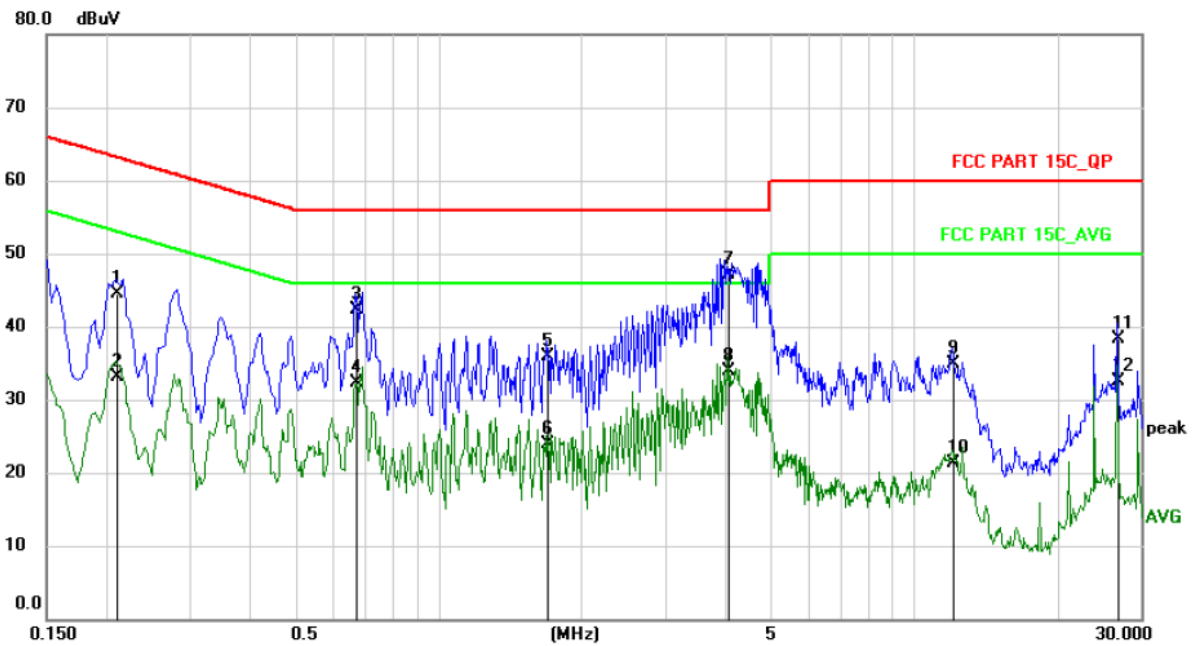

| No. Mk. | Freq. | Reading Level | Correct Factor | Measurement | Limit | Over | Detector | Comment |
|---------|---------|---------------|----------------|-------------|-------|--------|----------|---------|
| | MHz | dBuV | dB | dBuV | dBuV | dB | | |
| 1 | 0.2100 | 33.90 | 10.60 | 44.50 | 63.21 | -18.71 | QP | |
| 2 | 0.2100 | 22.60 | 10.60 | 33.20 | 53.21 | -20.01 | AVG | |
| 3 | 0.6700 | 31.75 | 10.65 | 42.40 | 56.00 | -13.60 | QP | |
| 4 | 0.6700 | 21.75 | 10.65 | 32.40 | 46.00 | -13.60 | AVG | |
| 5 | 1.6940 | 25.30 | 10.70 | 36.00 | 56.00 | -20.00 | QP | |
| 6 | 1.6940 | 13.20 | 10.70 | 23.90 | 46.00 | -22.10 | AVG | |
| 7 * | 4.0619 | 36.49 | 10.71 | 47.20 | 56.00 | -8.80 | QP | |
| 8 | 4.0619 | 23.19 | 10.71 | 33.90 | 46.00 | -12.10 | AVG | |
| 9 | 12.0340 | 24.26 | 10.74 | 35.00 | 60.00 | -25.00 | QP | |
| 10 | 12.0340 | 10.66 | 10.74 | 21.40 | 50.00 | -28.60 | AVG | |
| 11 | 26.8140 | 27.61 | 10.79 | 38.40 | 60.00 | -21.60 | QP | |
| 12 | 26.8140 | 21.81 | 10.79 | 32.60 | 50.00 | -17.40 | AVG | |

13.2 Radiated Spurious Emissions and Restricted Bands Measurement

LIMITS

| Frequency range MHz | Distance Meters | Field Strengths Limit (15.209) |
|------------------------|-----------------|--------------------------------|
| | | $\mu\text{V/m}$ |
| 0.009 ~ 0.490 | 300 | 2400/F(kHz) |
| 0.490 ~ 1.705 | 30 | 24000/F(kHz) |
| 1.705 ~ 30 | 30 | 30 |
| 30 ~ 88 | 3 | 100 |
| 88 ~ 216 | 3 | 150 |
| 216 ~ 960 | 3 | 200 |
| Above 960 | 3 | 500 |

- Remark:
- (1) Emission level (dB) μV = 20 log Emission level $\mu\text{V/m}$
 - (2) The smaller limit shall apply at the cross point between two frequency bands.
 - (3) As shown in 15.35(b), for frequencies above 1000MHz, the field strength limits are based on average detector, however, the peak field strength of any emission shall not exceed the maximum permitted average limits, specified above by more than 20dB under any condition of modulation.
 - (4) The frequency range scanned is from the lowest radio frequency signal generated in the device which is greater than 9 kHz to the tenth harmonic of the highest fundamental frequency or 40 GHz, whichever is lower.
 - (5) §15.247(d) specifies that emissions which fall in the restricted bands, as defined in §15.205 comply with radiated emission limits specified in §15.209.

BLOCK DIAGRAM OF TEST SETUP

For Radiated Emission below 30MHz

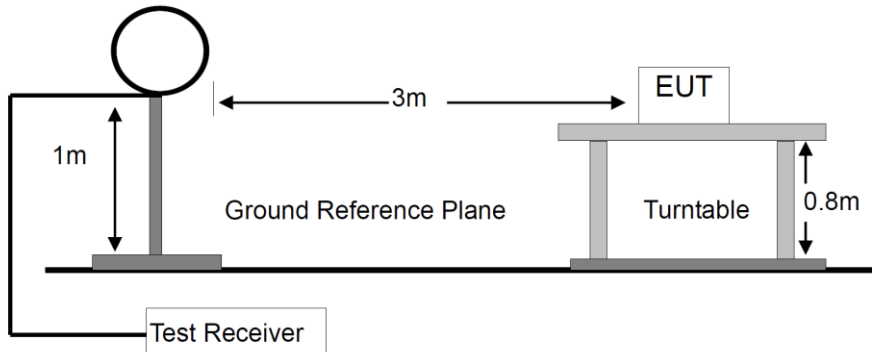

For Radiated Emission 30-1000MHz

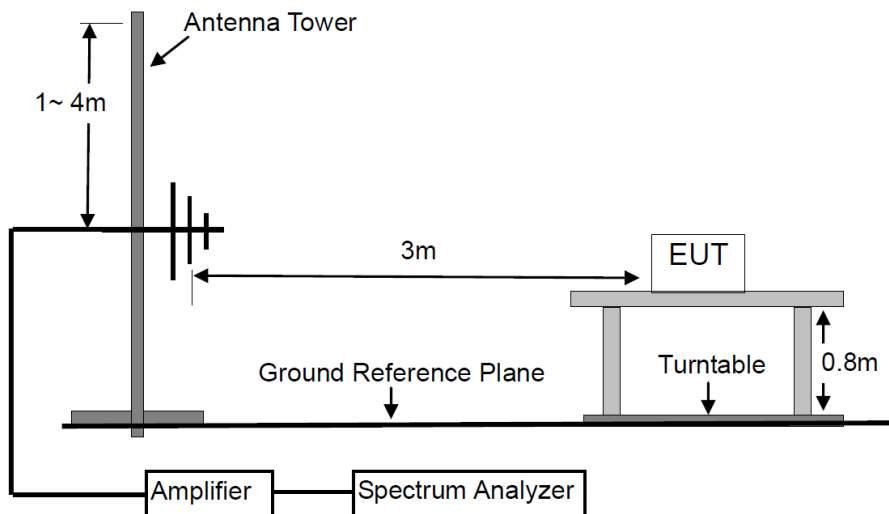

For Radiated Emission Above 1000MHz.

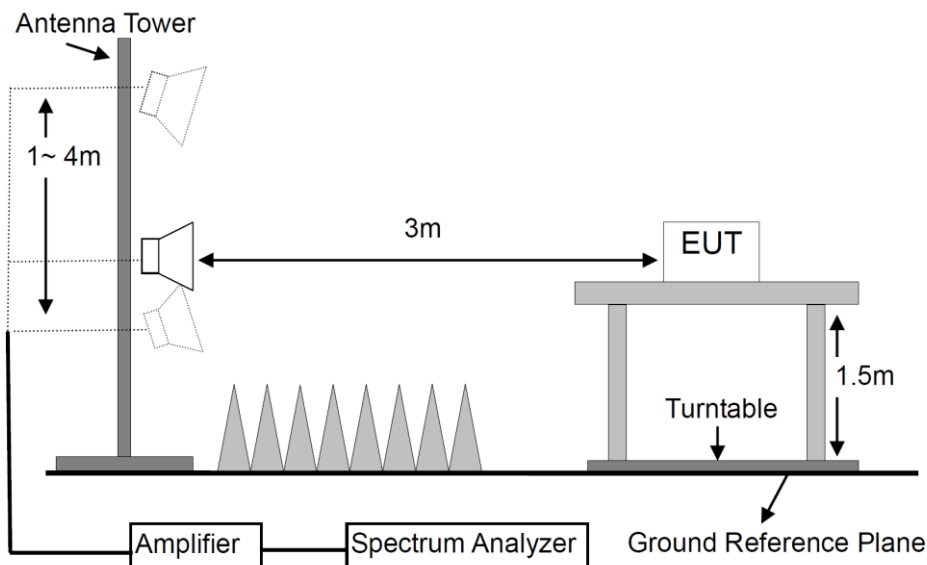

TEST PROCEDURES

- a. Below 1GHz, the EUT was placed on the top of a rotating table 0.8 meters above the ground at a 3 meter semi- anechoic chamber room.
- b. For the radiated emission test above 1GHz:

The EUT was placed on the top of a rotating table 1.5 meters above the ground at a 3 meter full anechoic chamber room. The table was rotated 360 degrees to determine the position of the highest radiation. Place the measurement antenna away from each area of the EUT determined to be a source of emissions at the specified measurement distance, while keeping the measurement antenna aimed at the source of emissions at each frequency of significant emissions, with polarization oriented for maximum response. The measurement antenna may have to be higher or lower than the EUT, depending on the radiation pattern of the emission and staying aimed at the emission source for receiving the maximum signal. The final measurement antenna elevation shall be that which maximizes the emissions. The measurement antenna elevation for maximum emissions shall be restricted to a range of heights of from 1 m to 4 m above the ground or reference ground plane.
- c. The EUT was set 3 meters away from the interference-receiving antenna, which was mounted on the top of a variable-height antenna tower.
- d. The height of antenna is varied from one meter to four meters above the ground to determine the maximum value of the field strength. Both horizontal and vertical polarizations of the antenna are set to make the measurement.
- e. For each suspected emission, the EUT was arranged to its worst case and then the antenna was tuned to heights from 1 meter to 4 meters and the rotatable table was turned from 0 degrees to 360 degrees to find the maximum reading. The test-receiver system was set to peak detect function and specified bandwidth with maximum hold mode.
- f. A Quasi-peak measurement was then made for that frequency point for below 1GHz test. PK and AV for above 1GHz emission test.

During the radiated emission test, the spectrum analyzer was set with the following configurations:

| Frequency Band (MHz) | Detector | Resolution Bandwidth | Video Bandwidth |
|----------------------|----------|----------------------|-----------------|
| 30 to 1000 | QP | 120 kHz | 300 kHz |
| Above 1000 | Peak | 1 MHz | 3 MHz |
| | Average | 1 MHz | 10 Hz |

TEST RESULTS

PASS

Please refer to the following pages of the worst case.

| | |
|----------------------------------|-------------------------------|
| M/N: ZEN Blue V2 | Testing Voltage: AC 120V/60Hz |
| Polarization: Horizontal | Detector: QP |
| Test Mode: 1 (8DPSK Low channel) | Distance: 3m |

Radiated Emission Measurement

Date: 2022/4/11

Time: 9:09:51

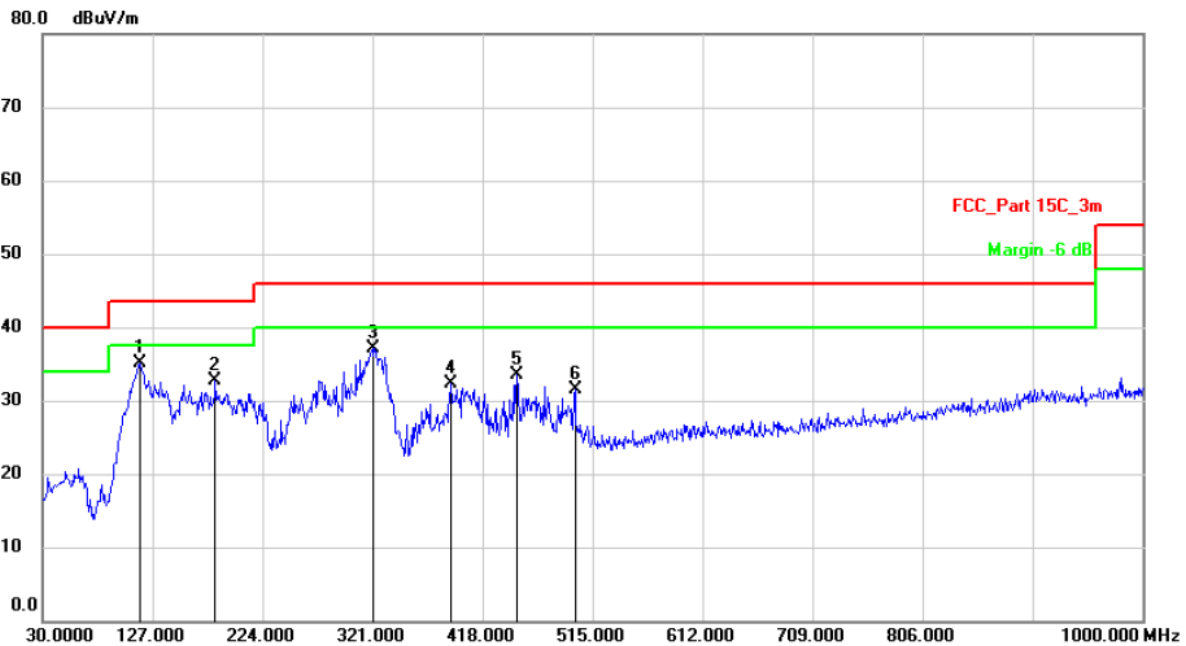

| No. | Mk. | Freq. MHz | Reading Level dBuV | Correct Factor dB/m | Measure- ment dBuV/m | Limit dBuV/m | Over dB | Detector | Comment |
|-----|-----|--------------|--------------------------|---------------------------|----------------------------|-----------------|------------|----------|---------|
| 1 | * | 116.3300 | 43.80 | -8.62 | 35.18 | 43.50 | -8.32 | QP | |
| 2 | | 182.2899 | 41.74 | -9.01 | 32.73 | 43.50 | -10.77 | QP | |
| 3 | | 321.0000 | 42.09 | -4.95 | 37.14 | 46.00 | -8.86 | QP | |
| 4 | | 389.8700 | 35.91 | -3.54 | 32.37 | 46.00 | -13.63 | QP | |
| 5 | | 448.0700 | 36.16 | -2.57 | 33.59 | 46.00 | -12.41 | QP | |
| 6 | | 499.4800 | 33.21 | -1.78 | 31.43 | 46.00 | -14.57 | QP | |

Note: Below 30MHz, the emissions are lower than 20dB below the allowable limit.

| | |
|----------------------------------|-------------------------------|
| M/N: ZEN Blue V2 | Testing Voltage: AC 120V/60Hz |
| Polarization: Vertical | Detector: QP |
| Test Mode: 1 (8DPSK Low channel) | Distance: 3m |

Radiated Emission Measurement

Date: 2022/4/11

Time: 9:02:28

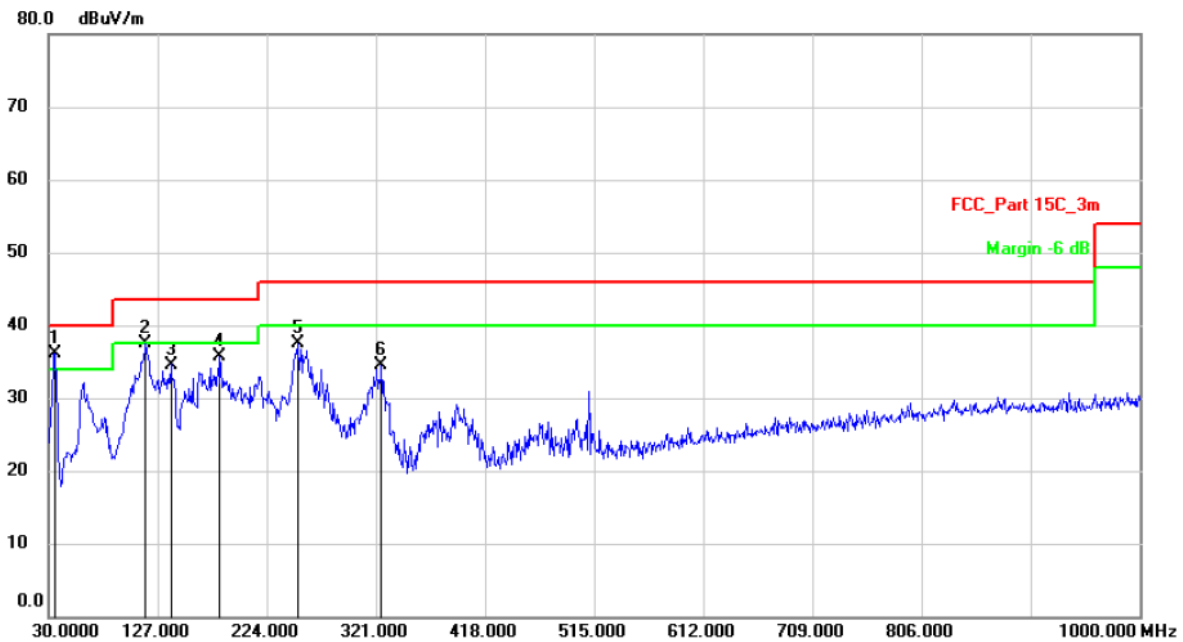

| No. | Mk. | Freq. MHz | Reading Level dBuV | Correct Factor dB/m | Measure- ment dBuV/m | Limit dBuV/m | Over dB | Detector | Comment |
|-----|-----|--------------|--------------------------|---------------------------|----------------------------|-----------------|------------|----------|---------|
| 1 | * | 35.8200 | 45.09 | -8.91 | 36.18 | 40.00 | -3.82 | QP | |
| 2 | | 116.3300 | 48.39 | -10.90 | 37.49 | 43.50 | -6.01 | QP | |
| 3 | | 138.6400 | 46.05 | -11.45 | 34.60 | 43.50 | -8.90 | QP | |
| 4 | | 182.2899 | 45.04 | -9.31 | 35.73 | 43.50 | -7.77 | QP | |
| 5 | | 252.1300 | 44.88 | -7.31 | 37.57 | 46.00 | -8.43 | QP | |
| 6 | | 325.8500 | 40.34 | -5.78 | 34.56 | 46.00 | -11.44 | QP | |

Note: Below 30MHz, the emissions are lower than 20dB below the allowable limit.

| Modulation: 8DPSK (the worst case) | | | | Test Result: PASS | | | Test frequency range: 1-25GHz | | | |
|---|-----------------|---------------------|-------|-------------------|-------------------------|-------|-------------------------------|-------|-------------|--------|
| Freq. (MHz) | Ant. Pol. (H/V) | Reading Level(dBuV) | | Factor (dB/m) | Emission Level (dBuV/m) | | Limit 3m (dBuV/m) | | Margin (dB) | |
| | | PK | AV | | PK | AV | PK | AV | PK | AV |
| Operation Mode: TX Mode (Low) | | | | | | | | | | |
| 4804 | V | 53.58 | 43.35 | 6.30 | 59.88 | 49.65 | 74.00 | 54.00 | -14.12 | -4.35 |
| 7206 | V | 50.76 | 40.02 | 10.44 | 61.20 | 50.46 | 74.00 | 54.00 | -12.80 | -3.54 |
| --- | | | | | | | | | | |
| 4804 | H | 55.13 | 44.39 | 6.30 | 61.43 | 50.69 | 74.00 | 54.00 | -12.57 | -3.31 |
| 7206 | H | 48.92 | 37.90 | 10.44 | 59.36 | 48.34 | 74.00 | 54.00 | -14.64 | -5.66 |
| --- | | | | | | | | | | |
| Operation Mode: TX Mode (Mid) | | | | | | | | | | |
| 4882 | V | 57.32 | 47.10 | 6.60 | 63.92 | 53.70 | 74.00 | 54.00 | -10.08 | -0.30 |
| 7323 | V | 49.64 | 38.08 | 10.55 | 60.19 | 48.63 | 74.00 | 54.00 | -13.81 | -5.37 |
| --- | | | | | | | | | | |
| 4882 | H | 55.82 | 45.81 | 6.60 | 62.42 | 52.41 | 74.00 | 54.00 | -11.58 | -1.59 |
| 7323 | H | 48.46 | 37.01 | 10.55 | 59.01 | 47.56 | 74.00 | 54.00 | -14.99 | -6.44 |
| --- | | | | | | | | | | |
| Operation Mode: TX Mode (High) | | | | | | | | | | |
| 4960 | V | 56.15 | 45.87 | 6.89 | 63.04 | 52.76 | 74.00 | 54.00 | -10.96 | -1.24 |
| 7440 | V | 49.28 | 37.15 | 10.60 | 59.88 | 47.75 | 74.00 | 54.00 | -14.12 | -6.25 |
| --- | | | | | | | | | | |
| 4960 | H | 55.30 | 45.72 | 6.89 | 62.19 | 52.61 | 74.00 | 54.00 | -11.81 | -1.39 |
| 7440 | H | 48.60 | 36.43 | 10.60 | 59.20 | 47.03 | 74.00 | 54.00 | -14.80 | -6.97 |
| --- | | | | | | | | | | |
| Spurious Emission in restricted band: | | | | | | | | | | |
| 2390.000 | V | 53.94 | 37.32 | 0.09 | 54.03 | 37.41 | 74.00 | 54.00 | -19.97 | -16.59 |
| 2390.000 | H | 47.37 | 36.45 | 0.09 | 47.46 | 36.54 | 74.00 | 54.00 | -26.54 | -17.46 |
| 2483.500 | V | 68.41 | 44.34 | 0.35 | 68.76 | 44.69 | 74.00 | 54.00 | -5.24 | -9.31 |
| 2483.500 | H | 63.60 | 38.51 | 0.35 | 63.95 | 38.86 | 74.00 | 54.00 | -10.05 | -15.14 |
| Remark: Data of measurement within this frequency range shown “---” in the table above means the reading of emissions are attenuated more than 20dB below the permissible limits. | | | | | | | | | | |

13.3 Channel Separation test

LIMITS

Frequency hopping systems operating in the 2400-2483.5 MHz band may have hopping channel carrier frequencies that are separated by 25 kHz or two-thirds of the 20 dB bandwidth of the hopping channel, whichever is greater.

BLOCK DIAGRAM OF TEST SETUP

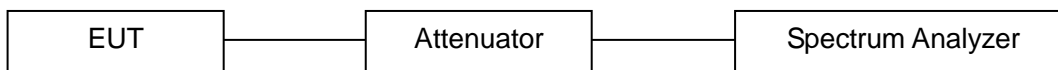

TEST PROCEDURES

- a. The RF output of EUT was connected to the spectrum analyzer by RF cable and attenuator. The path loss was compensated to the results for each measurement.
- b. Set to the maximum power setting and enable the EUT transmit continuously.
- c. Enable the EUT hopping function.
- d. Set spectrum analyzer and perform testing according to ANSI C63.10-2013 clause 7.8.2.

TEST RESULTS

PASS

Please refer to the following table.

| Modulation | Channel | Frequency (MHz) | Hopping Separation Measurement (KHz) | Hopping Separation Limit (KHz) | Test Result |
|----------------|---------|-----------------|--------------------------------------|--------------------------------|-------------|
| GFSK | Low | 2402 | 1009 | >621.9 | Pass |
| | Mid | 2441 | 999 | >621.4 | Pass |
| | High | 2480 | 999 | >620.1 | Pass |
| $\pi/4$ -DQPSK | Low | 2402 | 999 | >894.7 | Pass |
| | Mid | 2441 | 999 | >895.3 | Pass |
| | High | 2480 | 1005 | >896.7 | Pass |
| 8DPSK | Low | 2402 | 999 | >877.3 | Pass |
| | Mid | 2441 | 999 | >879.3 | Pass |
| | High | 2480 | 999 | >878.0 | Pass |



8DPSK / Low Channel



8DPSK / Mid Channel

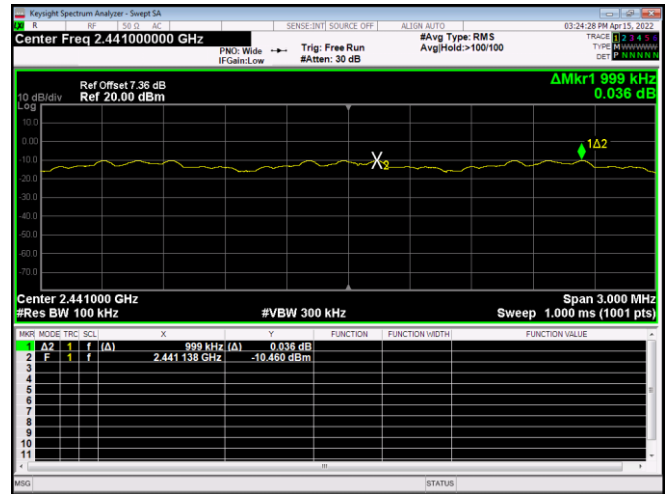

8DPSK / High Channel

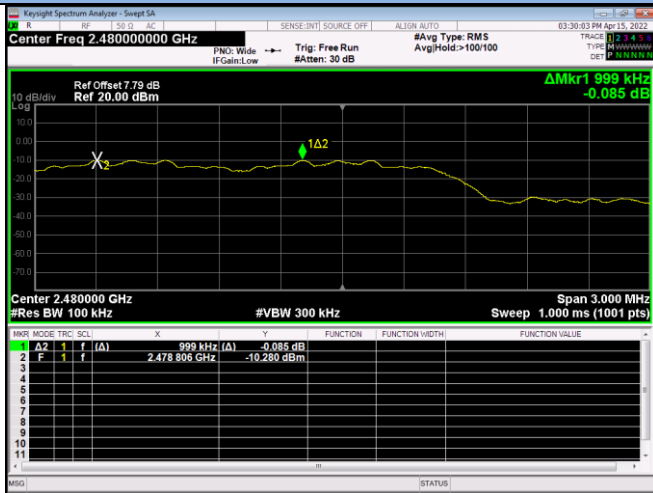

Blank

13.4 20dB Bandwidth

LIMITS

N/A

BLOCK DIAGRAM OF TEST SETUP

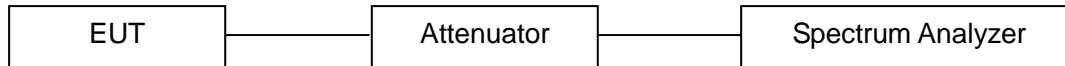

TEST PROCEDURES

- a. The RF output of EUT was connected to the spectrum analyzer by RF cable and attenuator. The path loss was compensated to the results for each measurement.
- b. Set to the maximum power setting and enable the EUT transmit continuously.
- c. Set spectrum analyzer and perform testing according to ANSI C63.10-2013 clause 6.9.2.

TEST RESULTS

PASS

Please refer to the following table.

| Modulation | Channel | Frequency (MHz) | 20dB Measurement (KHz) | Limit (KHz) | Remark |
|----------------|---------|-----------------|------------------------|-------------|----------------|
| GFSK | Low | 2402 | 932.8 | --- | Reporting only |
| | Mid | 2441 | 932.1 | --- | |
| | High | 2480 | 930.2 | --- | |
| $\pi/4$ -DQPSK | Low | 2402 | 1342 | --- | |
| | Mid | 2441 | 1343 | --- | |
| | High | 2480 | 1345 | --- | |
| 8DPSK | Low | 2402 | 1316 | --- | |
| | Mid | 2441 | 1319 | --- | |
| | High | 2480 | 1317 | --- | |

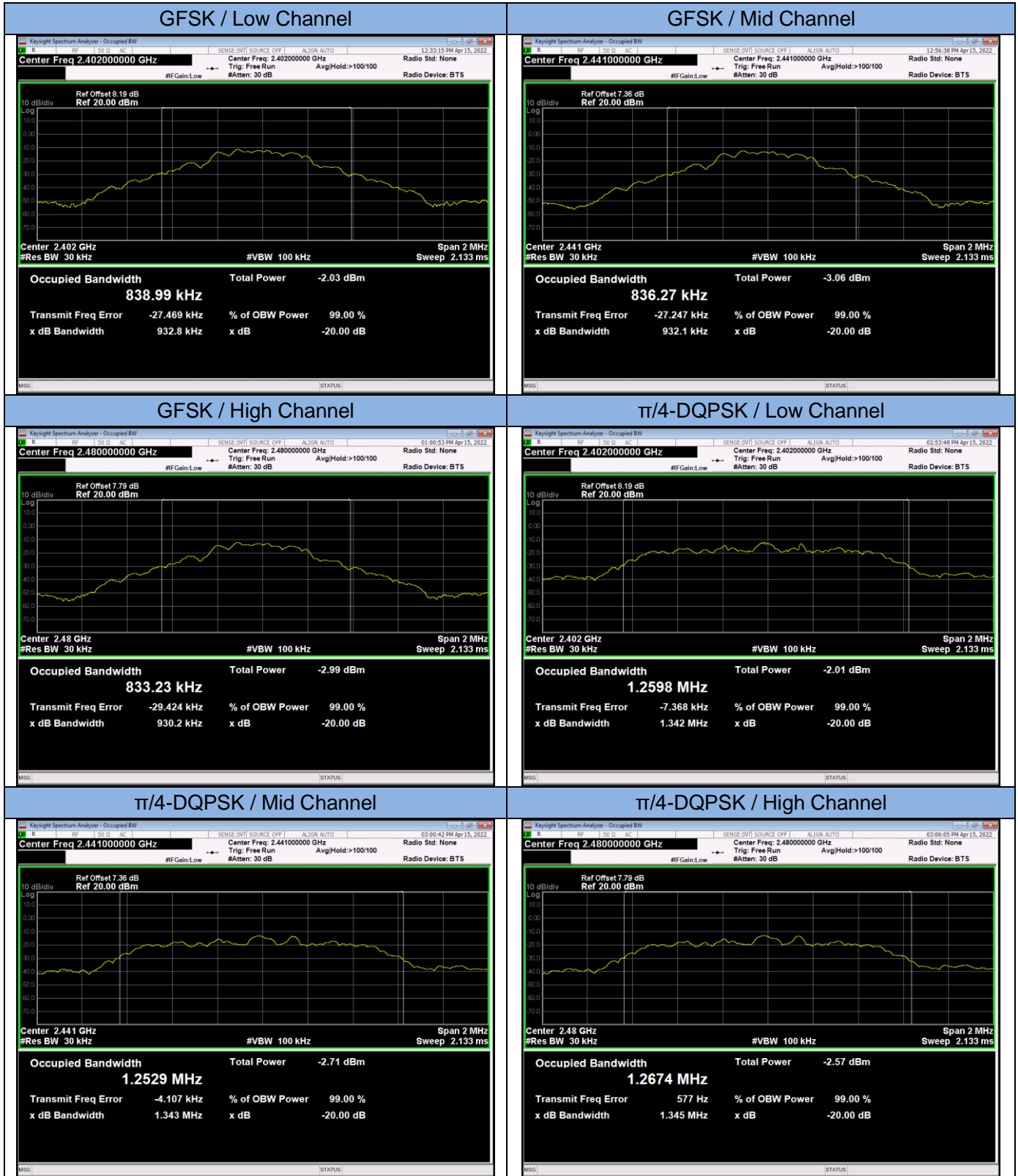

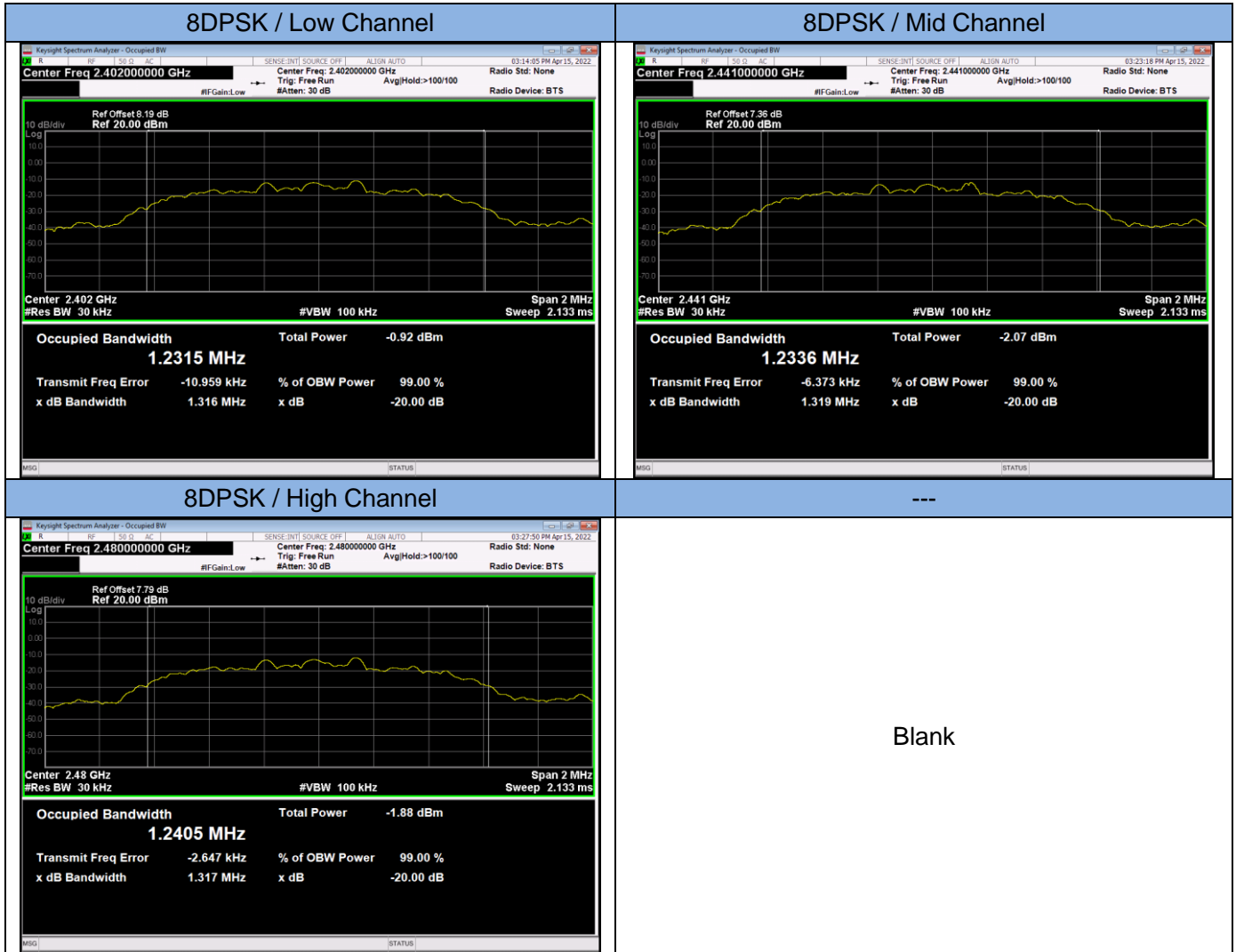

13.5 Hopping Channel Number

LIMITS

Frequency hopping systems in the 2400-2483.5MHz band shall use at least 15 channels.

BLOCK DIAGRAM OF TEST SETUP

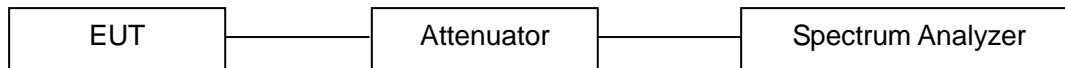

TEST PROCEDURES

- a. The RF output of EUT was connected to the spectrum analyzer by RF cable and attenuator. The path loss was compensated to the results for each measurement.
- b. Set to the maximum power setting and enable the EUT transmit continuously.
- c. Enable the EUT hopping function.
- d. Set spectrum analyzer and perform testing according to ANSI C63.10-2013 clause 7.8.3.

TEST RESULTS

PASS

Please refer to the following table.

| Modulation | Number of Hopping Channels Measurement | Limit | Test Result |
|------------|--|-------|-------------|
| GFSK | 79 | ≥15 | PASS |
| π/4-DQPSK | 79 | ≥15 | PASS |
| 8DPSK | 79 | ≥15 | PASS |

The worst case: 8DPSK

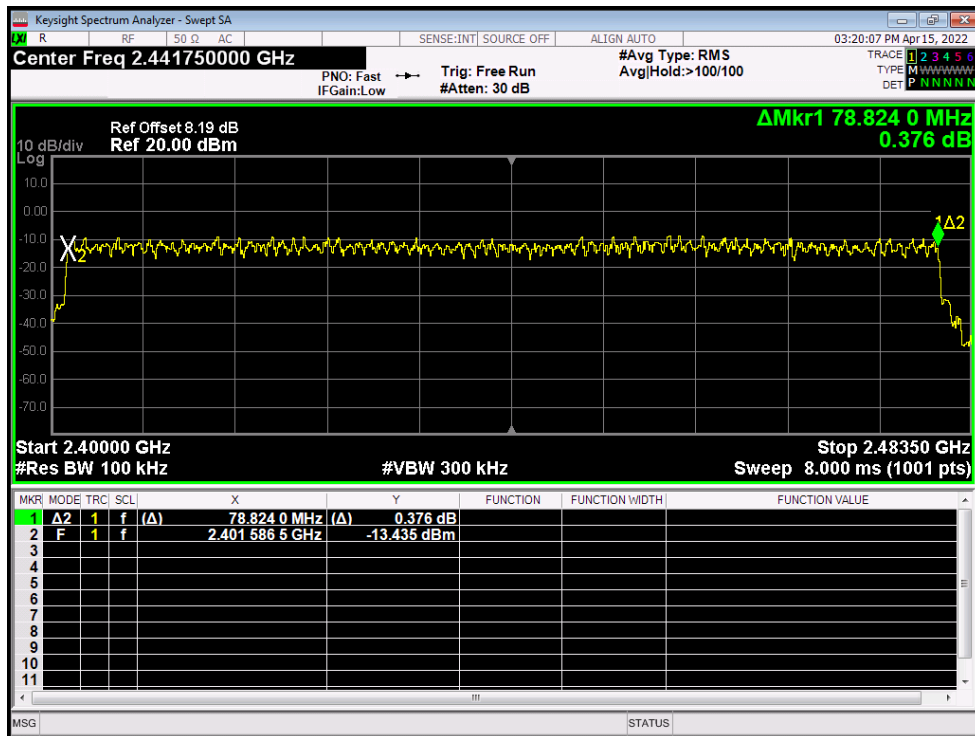

13.6 Time of Occupancy (Dwell Time)

LIMITS

The average time of occupancy on any channel shall not be greater than 0.4 seconds within a period of 0.4 seconds multiplied by the number of hopping channels employed.

BLOCK DIAGRAM OF TEST SETUP

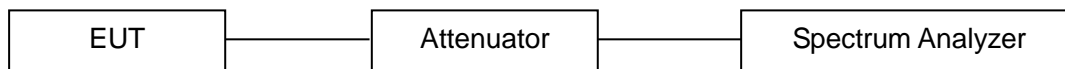

TEST PROCEDURES

- a. The RF output of EUT was connected to the spectrum analyzer by RF cable and attenuator. The path loss was compensated to the results for each measurement.
- b. Set to the maximum power setting and enable the EUT transmit continuously.
- c. Enable the EUT hopping function.
- d. Set spectrum analyzer and perform testing according to ANSI C63.10-2013 clause 7.8.4.

TEST RESULTS

PASS

Please refer to the following table.

| Modulation | Packet | Frequency (MHz) | Dwell Time Measurement (msec) | | Limit (msec) | Test Result |
|----------------|--------|-----------------|-------------------------------|--|--------------|-------------|
| GFSK | DH1 | 2441 | 0.383 | $(ms) * (1600 / (2 * 79)) * 31.6 = 122.56$ | 400 | Pass |
| | DH3 | 2441 | 1.635 | $(ms) * (1600 / (4 * 79)) * 31.6 = 261.60$ | 400 | Pass |
| | DH5 | 2441 | 2.885 | $(ms) * (1600 / (6 * 79)) * 31.6 = 307.73$ | 400 | Pass |
| $\pi/4$ -DQPSK | 2-DH1 | 2441 | 0.383 | $(ms) * (1600 / (2 * 79)) * 31.6 = 122.56$ | 400 | Pass |
| | 2-DH3 | 2441 | 1.640 | $(ms) * (1600 / (4 * 79)) * 31.6 = 262.40$ | 400 | Pass |
| | 2-DH5 | 2441 | 2.893 | $(ms) * (1600 / (6 * 79)) * 31.6 = 308.59$ | 400 | Pass |
| 8DPSK | 3-DH1 | 2441 | 0.380 | $(ms) * (1600 / (2 * 79)) * 31.6 = 121.60$ | 400 | Pass |
| | 3-DH3 | 2441 | 1.640 | $(ms) * (1600 / (4 * 79)) * 31.6 = 262.40$ | 400 | Pass |
| | 3-DH5 | 2441 | 2.893 | $(ms) * (1600 / (6 * 79)) * 31.6 = 308.59$ | 400 | Pass |

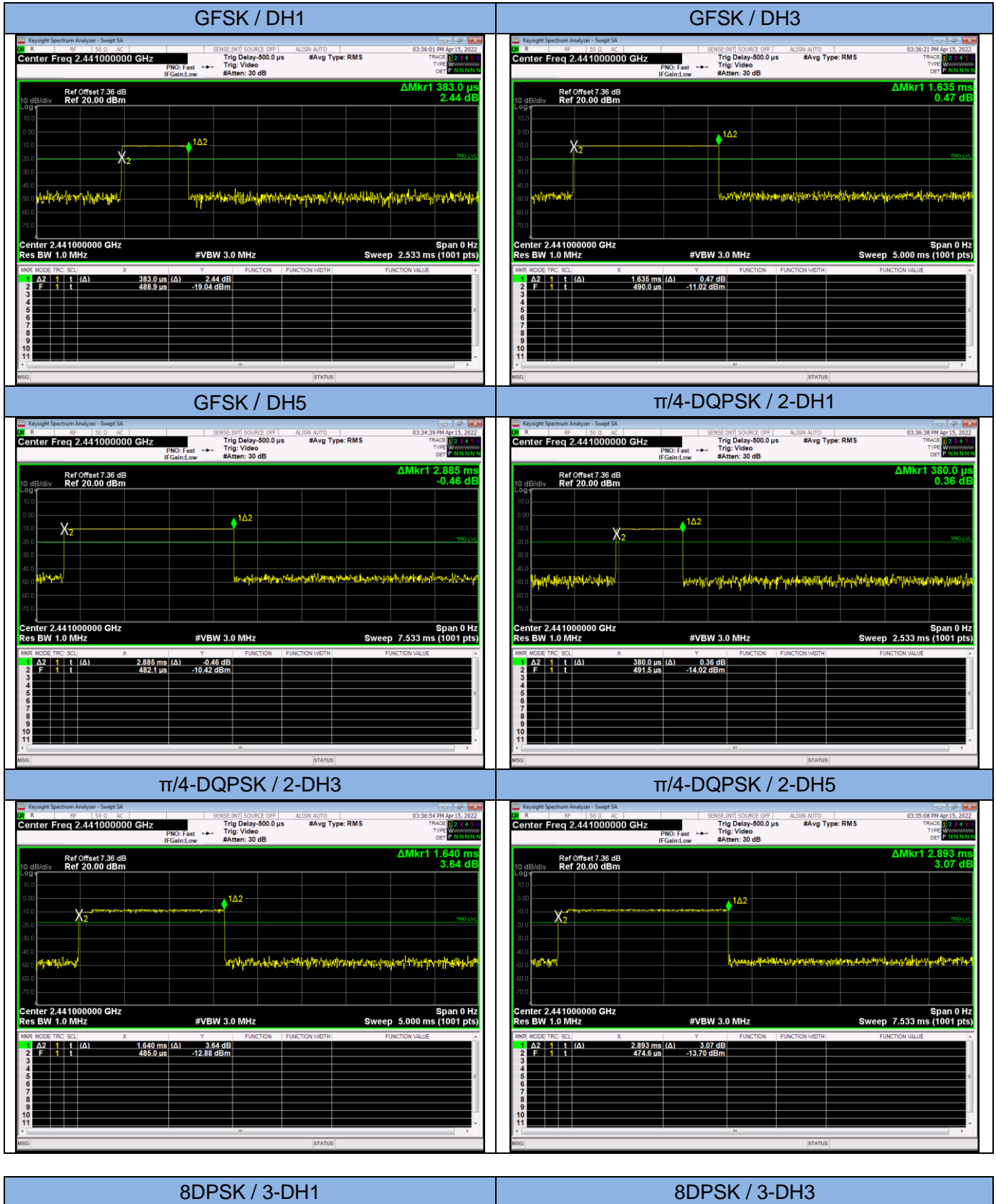

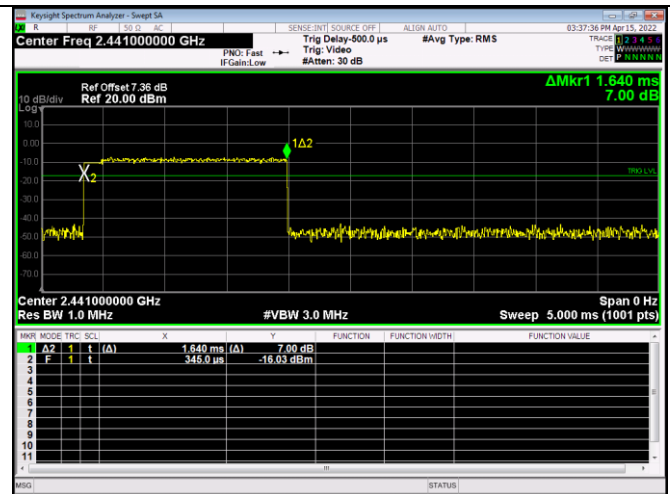
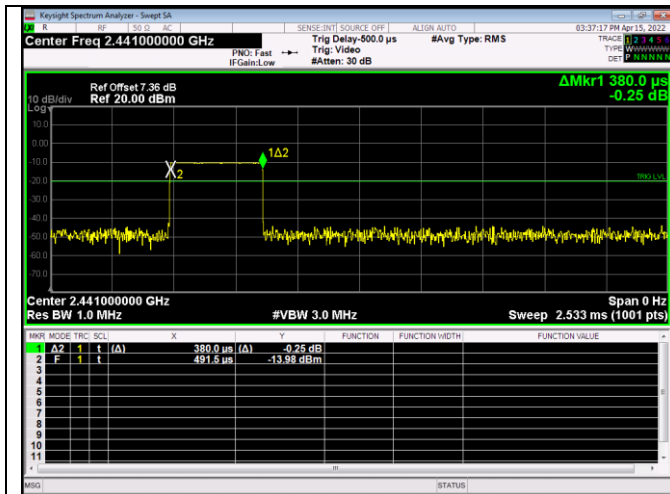

8DPSK / 3-DH5

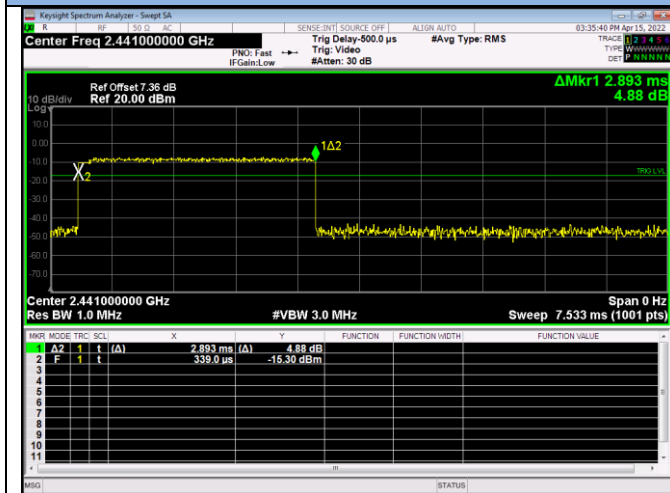

Blank

13.7 Maximum Peak Output Power

LIMITS

The maximum peak conducted output power of the intentional radiator shall not exceed the following: For frequency hopping systems operating in the 2400-2483.5 MHz band employing at least 75 non-overlapping hopping channels, and all frequency hopping systems in the 5725-5850 MHz band: 1 watt. For all other frequency hopping systems in the 2400-2483.5 MHz band 0.125 watts.

BLOCK DIAGRAM OF TEST SETUP

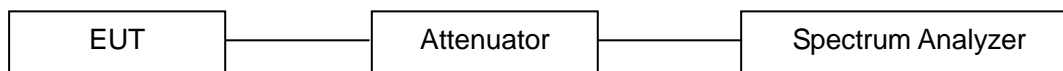

TEST PROCEDURES

- a. The RF output of EUT was connected to the spectrum analyzer by RF cable and attenuator. The path loss was compensated to the results for each measurement.
- b. Set to the maximum power setting and enable the EUT transmit continuously.
- c. Set spectrum analyzer and perform testing according to ANSI C63.10-2013 clause 7.8.5.

TEST RESULTS

PASS

Please refer to the following table.

| Modulation | Frequency (MHz) | Peak Power output Measurement (dBm) | Peak Power output Measurement (mW) | Peak Power Limit (dBm) | Test Result |
|----------------|-----------------|-------------------------------------|------------------------------------|------------------------|-------------|
| GFSK | 2402.00 | -9.191 | 0.12 | 20.97 | Pass |
| | 2441.00 | -10.140 | 0.10 | 20.97 | Pass |
| | 2480.00 | -10.077 | 0.10 | 20.97 | Pass |
| $\pi/4$ -DQPSK | 2402.00 | -6.207 | 0.24 | 20.97 | Pass |
| | 2441.00 | -7.392 | 0.18 | 20.97 | Pass |
| | 2480.00 | -7.304 | 0.19 | 20.97 | Pass |
| 8DPSK | 2402.00 | -5.662 | 0.27 | 20.97 | Pass |
| | 2441.00 | -6.848 | 0.21 | 20.97 | Pass |
| | 2480.00 | -6.699 | 0.21 | 20.97 | Pass |

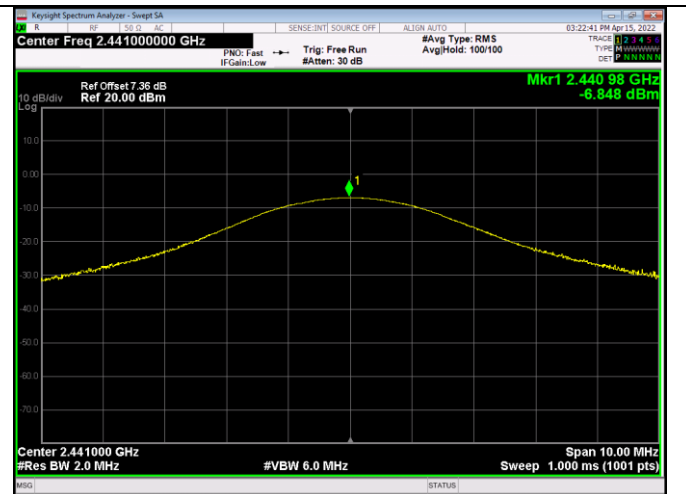
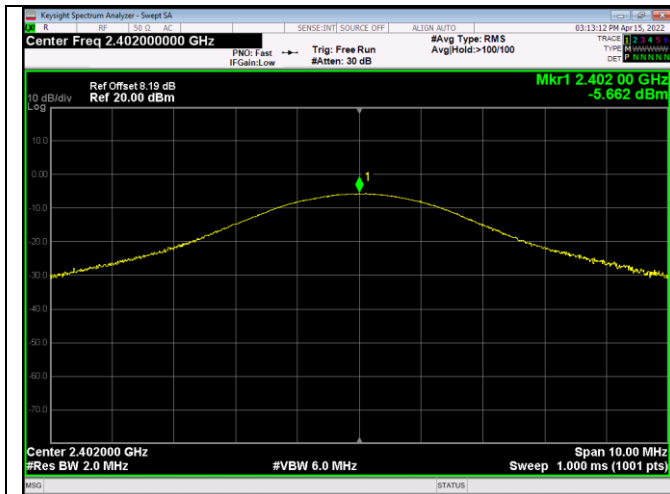

8DPSK / High Channel

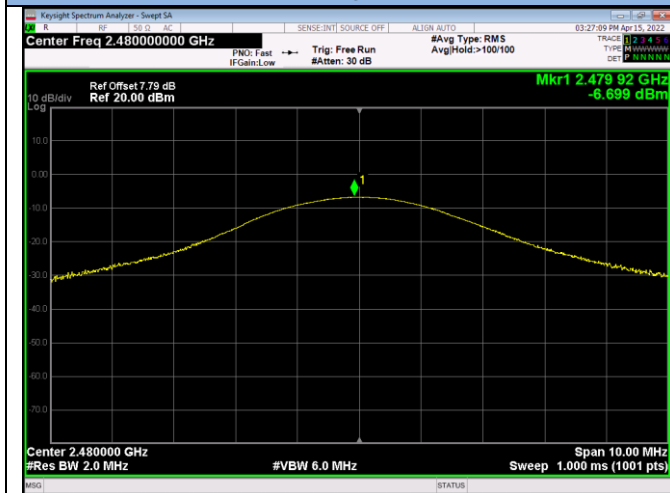

Blank

13.8 Band Edge Conducted Spurious Emission Measurement

LIMITS

In any 100KHz bandwidth outside the frequency band in which the spread spectrum intentional radiator is operating, the radio frequency power that is produced by the intentional radiator shall be at least 20dB below that in the 100KHz bandwidth within the band that contains the highest level of the desired power, based on either an RF conducted or a radiated measurement.

BLOCK DIAGRAM OF TEST SETUP

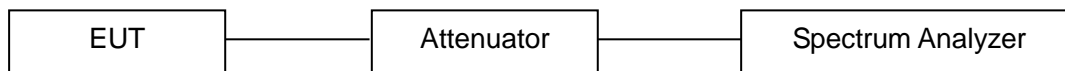

TEST PROCEDURES

- a. The RF output of EUT was connected to the spectrum analyzer by RF cable and attenuator. The path loss was compensated to the results for each measurement.
- b. Set to the maximum power setting and enable the EUT transmit continuously.
- c. Set spectrum analyzer and perform testing according to ANSI C63.10-2013 clause 7.8.6 and 6.10.
- d. Enable hopping function of the EUT and then repeat steps above.

TEST RESULTS

PASS

Please refer to the following test plots.

Band Edge



Band Edge

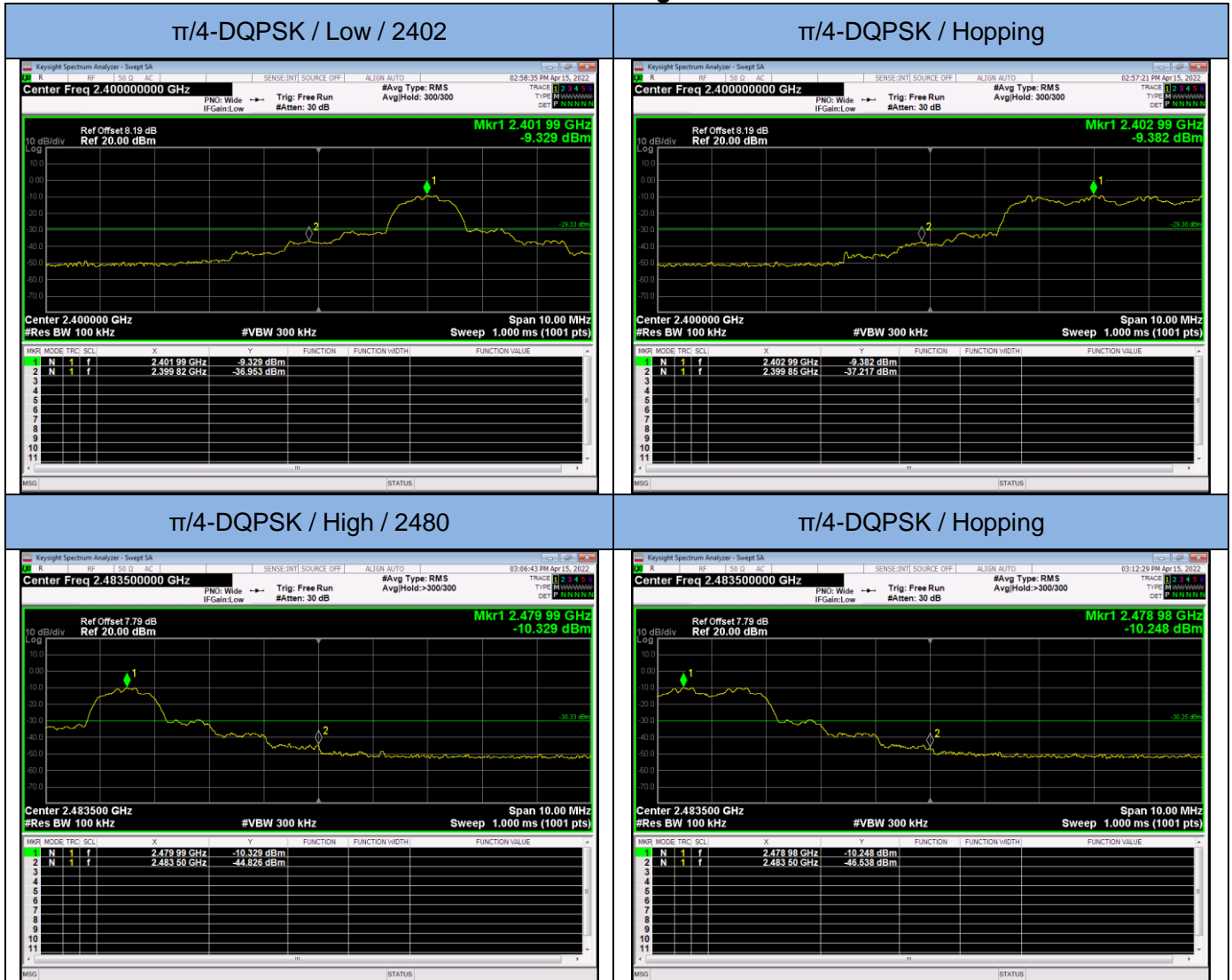

Band Edge



Conducted Spurious Emission (the worst case)

8DPSK / Low Channel / 30MHz~26.5GHz

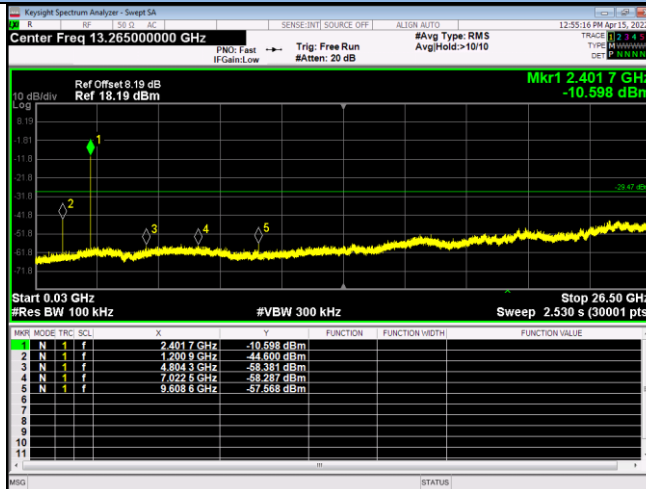

8DPSK / Mid Channel / 30MHz~26.5GHz

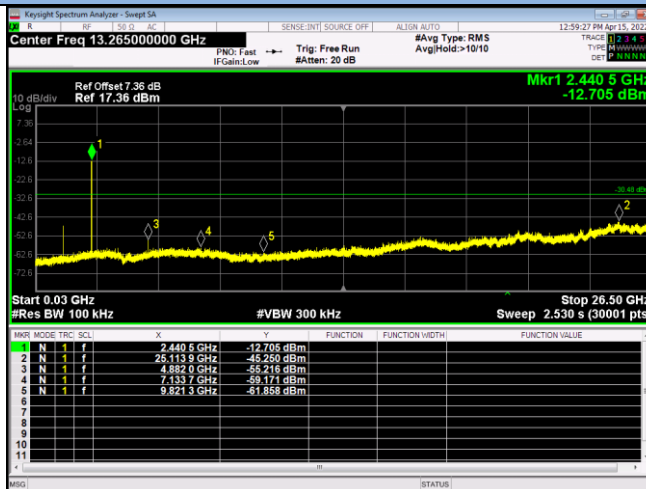

8DPSK / High Channel / 30MHz~26.5GHz

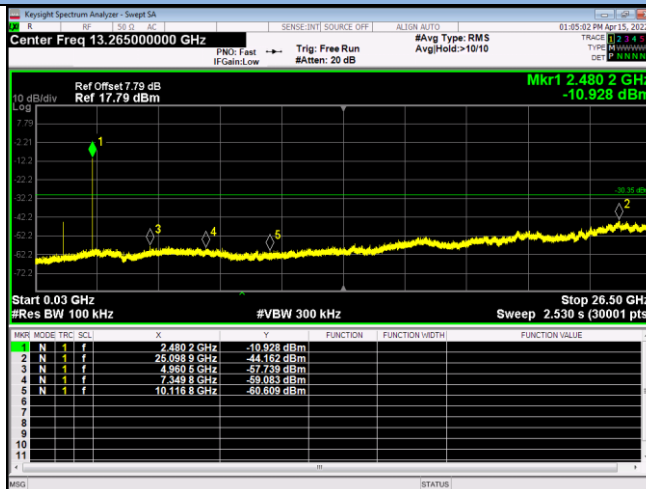

13.9 Antenna Requirement

STANDARD APPLICABLE

According to of FCC part 15C section 15.203 and 15.204:

An intentional radiator shall be designed to ensure that no antenna other than that furnished by the responsible party shall be used with the device. The use of a permanently attached antenna or of an antenna that uses a unique coupling to the intentional radiator, the manufacturer may design the unit so that a broken antenna can be replaced by the user, but the use of a standard antenna jack or electrical connector is prohibited.

Systems operating in the 2400-2483.5MHz band that are used exclusively for fixed, point-to-point operations may employ transmitting antennas with directional gain greater than 6dBi provided the maximum peak output power of the intentional radiator is reduced by 1dB for every 3dB that the directional gain of the antenna exceeds 6dBi.

ANTENNA CONNECTED CONSTRUCTION

The antenna is Integral antenna that no antenna other than furnished by the responsible party shall be used with the device, and the best case gain of the antenna is 3.0 dBi, Therefore, the antenna is consider meet the requirement.

14. Test Equipment List

| Item | Equipment | Manufacturer | Model No. | Serial No. | Last Cal. | Cal. Interval |
|------|--------------------------------|-----------------------------------|----------------------|-------------------|---------------|---------------|
| 1. | Test Receiver | Rohde & Schwarz | ESCI7 | 100837 | Mar. 13, 2022 | 1 Year |
| 2. | Antenna | Schwarzbeck | VULB9162 | 9162-010 | Mar. 23, 2022 | 1 Year |
| 3. | Spectrum Analyzer | Rohde & Schwarz | FSU26 | 200409/026 | Mar. 13, 2022 | 1 Year |
| 4. | Spectrum Analyzer | Keysight | N9020A | MY54200831 | Mar. 13, 2022 | 1 Year |
| 5. | Spectrum Analyzer | Rohde & Schwarz | FSV40 | 101094 | Mar. 13, 2022 | 1 Year |
| 6. | Horn Antenna | Schwarzbeck | BBHA9170 | 9170-172 | Mar. 23, 2022 | 2 Year |
| 7. | Power Sensor | DARE | RPR3006W | 15I00041SNO 64 | Mar. 13, 2022 | 1 Year |
| 8. | Communication Tester | Rohde & Schwarz | CMW500 | 149004 | Mar. 13, 2022 | 1 Year |
| 9. | Horn Antenna | COM-Power | AH-118 | 071078 | Mar. 23, 2022 | 1 Year |
| 10. | Pre-Amplifier | HP | HP 8449B | 3008A00964 | Mar. 13, 2022 | 1 Year |
| 11. | Pre-Amplifier | HP | HP 8447D | 1145A00203 | Mar. 13, 2022 | 1 Year |
| 12. | Loop Antenna | Schwarzbeck | FMZB 1513 | 1513-272 | Mar. 23, 2022 | 1 Year |
| 13. | Test Receiver | Rohde & Schwarz | ESCI | 101152 | Mar. 14, 2022 | 1 Year |
| 14. | L.I.S.N | Rohde & Schwarz | ENV 216 | 101317 | Mar. 13, 2022 | 1 Year |
| 15. | L.I.S.N | Rohde & Schwarz | ESH2-Z5 | 893606/014 | Mar. 13, 2022 | 1 Year |
| 16. | RF Switching Unit | Compliance Direction Systems Inc. | RSU-M2 | 38311 | Mar.13, 2022 | 1 Year |
| 17. | Temperature & Humidity Chamber | REMAFEE | SYHR225L | N/A | Mar. 13, 2022 | 1 Year |
| 18. | DC Source | Maynuo | MY8811 | N/A | Mar. 13, 2022 | 1 Year |
| 19. | Temporary antenna connector | TESCOM | SS402 | N/A | N/A | N/A |
| 20. | Chamber | SAEMC | 9*7*7m | N/A | Apr. 21, 2021 | 2 Year |
| 21. | Test Software | EZ | EZ EMC, NTC-3A1.1 | N/A | N/A | N/A |

Note: For photographs of EUT and measurement, please refer to appendix in separate documents.

---End---