

承 認 書

SPECIFICATION FOR APPROVAL

客 戶: CUSTOMER:	WeiE
客 戶 料 號: CUST P/N:	
音 澤 料 號: FINE P/N:	G43.5*0.5-13.8-0.08*105P-12T-6.8UH-W39.3-L180MM+ BJ
產 品 型 號: DESC:	Φ43.5MMX0.8MM
日 期: DATE:	2023/10/27
版 本: Version:	A.0

擬 制 PREPARED BY	審 核 CHECKED BY	批 准 APPROVED BY	客 戶 承 認 CUSTOMER APPROVE
黃小定			

東莞市來特好科技有限公司

Dongguan Lai Te Hao Technology Co., LTD

Factory address: Room 301, Building 9, No.2, Dongshan Industrial Street, Zhangluo Town, Dongguan, Guangdong, China

SPECIFICATION

產品型號: DESC	G43.5*0.8-13.8-0.08*105P-12 T*6.8UH-W39.3-L180MM+BJ	版本 Rev: A.0	客戶 CUST: 客戶料号 CUST P/N:	微鵝
---------------	--	----------------	----------------------------	-----------

一、尺寸 DIMENSION:(mm)

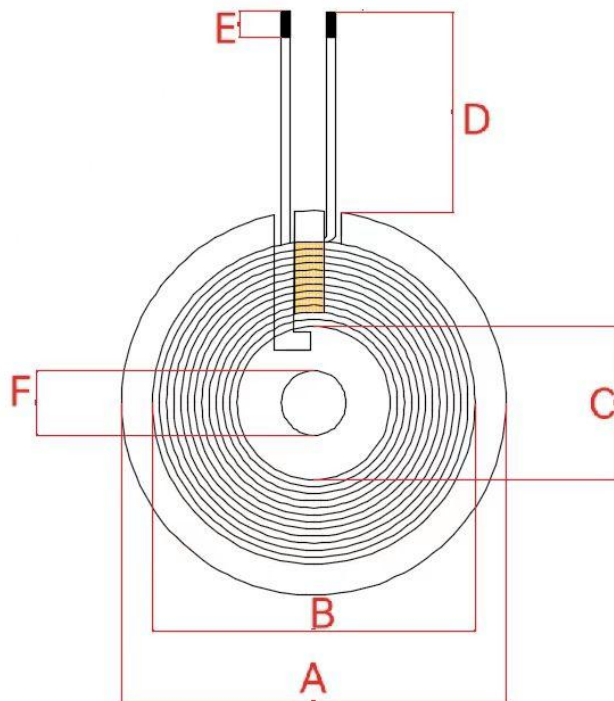

A	43.5±0.5
B	39.3±0.5
C	13.8±0.5
D	180 ±2
E	3±2
F	5.3±0.2
G	
H	
I	
K	

注:

- 1.交叉出线;
- 2.线圈贴 43.5 双槽磁片, 磁片尺寸 43.5±0.5mm, 厚度为 0.8±0.05mm.
- 3.磁片背面贴背胶

二、原理图 SCHEMATIC DIAGRAM:

三、绕线参数 Winding Specification:

序号 NO.	端子 TERMINAL		线径 WIRE	圈数 Turns	绕线方向 Winding Direction
1	S	F	丝包线 0.08*105P	12Ts	CCW

四、电气特性 ELECTRICAL CHARACTERISTICS:

温度 TEMPERATURE:25±10°C, 湿度 RELATIVE HUMIDITY:65±20%

序号 NO.	项目 ITEM	端子 TERMINAL	标准 SPECIFICATION	测试条件 TEST FREQUENCY	测试仪器 TEST EQUIPMENTS
1	IND.	S-F	3.8uH ±10%单独线圈	100KHz/1.0V	LCZ METER 1062B
2	IND.	S-F	6.8H ±10%加磁片	100KHz/1.0V	LCZ METER 1062B
3	DCR	S-F	≤55mΩ		LCZ METER 502B

擬制/日期 PREPARED BY/DATE	審核/日期 CHECKED BY/DATE
黃小定 2023.10.27	
