

SPECIFICATION FOR APPROVAL

CUSTOMER:

CUSTOMER P/N:

DESCRIPTION :

DATE:2023-2-13

SPECIFICATION : MPA2 slotted 15w+ adhesive back REV.NO.:A0

lead length 50mm

HRSW ELECTRONICS CO., LTD

Department	Confirm/Date	Check/Date	Approve/Date	Company seal
Quality	wanhong Dong ₂₀₂₃₋₂₋₁₃	hui Lv ₂₀₂₃₋₂₋₁₃	hanman Wei ₂₀₂₃₋₂₋₁₃	
engineering	weihua He ₂₀₂₃₋₂₋₁₃	lihong Wei ₂₀₂₃₋₂₋₁₃	lihong Wei ₂₀₂₃₋₂₋₁₃	

Note:

HRSW ELECTRONICS CO., LTD

Department	Confirm/Date	Check/Date	Approve/Date	
Engineering				
Purchase				
Quality				

Note :

HRSW ELECTRONICS CO.,LTD

ADD: Floor 2, Building 1, No.48 Guanlan Huanguan Middle Road, Longhua New District, Shenzhen

TEL: +86-755-23461055

FAX: +86-0755-28015170

page:1/3

SPECIFICATION FOR APPROVAL

1.MECHANICAL DIMENSION (UNIT:mm)

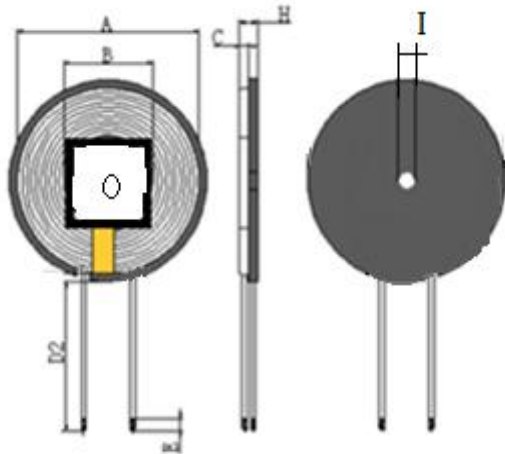

2. SCHEMATICS:

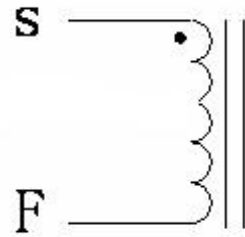

Coil gain:0dbi

A	B	C	D2	E	H
50±1	20±1	0.8±0.05	50±3	4±2	2.8MAX

3.WINDING:

STEP	START-FINISH	WIRE TYPE	TURNS	TAPE	REMARK
N1	S-F	丝包线 0.08*105mm 2UEW	12TS (Ref)		

4. ELECTRICAL SPECIFICATION:

ITEM	L	DCR	L	Q value	HI-POT
TEST COND	Coil plus magnetic sheet	S-F			
	100KHz, 0.25V	AT 25°C			
SPEC	10uH±10%	90mΩ Max			

5.BILF OF MATERIAL:

NO.	ITEM	MATERIAL SPECIFICATION	MANUFACTURER	SGS NO.
1	0.08*105 strands of silk covered wire	acetone	NANJINGJINNINGCO,LTD	
2	Lead-free tin bar	Lead-free tin bar	QIAODO	
3	magnetic sheet	50 Mn-Zn hard magnetic sheet with L slot	TAIYI CO.,LTD	
4	Glue	Yellow glue9999	LIANCHENG CO.,LTD	
5	High temperature adhesive tape	8mm High temperature adhesive tape	CUDAK CO.,LTD	

HRSW ELECTRONICS CO.,LTD	PART NO	
	TITLE	MPA2
DRAWN BY	CHECKED BY	APPROVED BY

SPECIFICATION FOR APPROVAL

6. SAMPLE TEST DATA									
6. 1DIMENSION TEST (UNIT:mm)									
TEST ITEM	A	B	C	D	E	H			
SPEC	50±1	19.5±0.5	0.8±0.05	50±3	4±2	2.8MAX			
1	50.01	19.8	0.82	50	3.50	2.45			
2	49.95	19.98	0.85	51	3.68	2.48			
3	49.98	19.9	0.89	50.6	3.79	2.43			
4	49.97	19.89	0.86	50.1	3.80	2.41			
5	50.01	19.82	0.87	52	4.00	2.40			
6									
7									
8									
9									
10									
MAX	50.01	19.98	0.89	52.00	4.00	2.48			
MIN	49.95	19.80	0.82	50.00	3.50	2.40			
AVERAGE	49.98	19.88	0.86	50.74	3.75	2.43			
6. 2ELECTRICAL TEST									
TEST ITEM	L		DCR	IDC		Q	HI-POT		
	S-F		S-F						
TEST COND	100KHz/0.25v		AT 25°C						
SPEC	10uH ±10%		90mΩ (Max)						
1	10.04		57.00						
2	9.98		59.00						
3	9.80		59.80						
4	9.96		60.00						
5	9.95		58.50						
6									
7									
8									
9									
10									
MAX	10.04		60.00						
MIN	9.80		57.00						
AVERAGE	9.95		58.86						
HRSW ELECTRONICS CO., LTD					PART NO				
					TITLE		MPA2		
DRAWN BY			CHECKED BY				APPROVED		