

BYD's self-made in-car detection antenna is used for keyless systems. A car is installed with 3 to 4 pieces, and different protective structures are selected according to the different installation positions. The relevant performance requirements of the antenna are as follows:

Work requirements

Conditions of Use

- a) Working temperature: $-40^{\circ}\text{C} \sim 80^{\circ}\text{C}$;
- b) Storage temperature: $-40^{\circ}\text{C} \sim 90^{\circ}\text{C}$;
- c) Working humidity: $0\% \sim 100\%$;
- d) Storage humidity: $0\% \sim 100\%$;
- d) Atmospheric pressure: $50\text{kPa} \sim 106\text{kPa}$.

technical parameter

Table 1 Low frequency emission frequency range

Nominal transmit frequency	Temperature (unit: $^{\circ}\text{C}$)	Transmit power range (unit: KHz)	
		min	max
125	$-40 \sim 80$	110	145
	$18 \sim 28$	120	130

Function and use: Send low-frequency signals to detect electronic keys.

Power supply mode: controller power supply

External interface: VBAT, GND

Product shape and size (product photos or design drawings can be provided):

Product usage scenarios

PKE\PKS

The electrical parameters of the product, input and output voltage and current, etc.

Steady-state working current 120mA

Inrush current and locked rotor current 200mA

Working voltage 9-16V

The wireless parameters of the product, such as the frequency used, the modulation method $125\text{KHz} \pm 3\text{KHz}$, the modulation method refers to the whole vehicle

The simple working principle of the product

The controller supplies power to the antenna to drive the antenna to transmit low-frequency signals, and the electronic key receives low-frequency signals to transmit high-frequency signals to the vehicle for authentication.

What is the specific communication of wireless transmission (reception) specifications, Bluetooth, wifi, 2/3/4/5G working frequency band

low frequency communication

Transmit and receive power

No rated power, calculated from the controller supply voltage and current.

Installation location

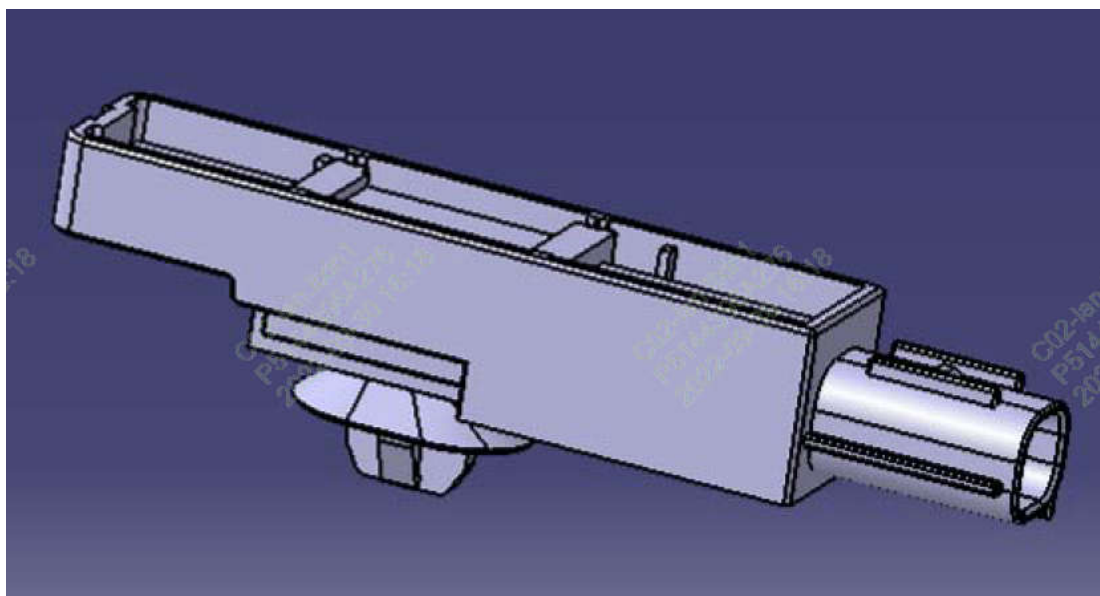

Any Changes or modifications not expressly approved by the party responsible for compliance could void the user's authority to operate the equipment.

This device complies with part 15 of the FCC Rules. Operation is subject to the following two conditions:

- (1) This device may not cause harmful interference, and
- (2) this device must accept any interference received, including interference that may cause undesired operation.

Note: This equipment has been tested and found to comply with the limits for a Class B digital device, pursuant to part 15 of the FCC Rules. These limits are designed to provide reasonable protection against harmful interference in a residential installation. This equipment generates uses and can radiate radio frequency energy and, if not installed and used in accordance with the instructions, may cause harmful interference to radio communications. However, there is no guarantee that interference will not occur in a particular installation. If this equipment does cause harmful interference to radio or television reception, which can be determined by turning the equipment off and on, the user is encouraged to try to correct the interference by one or more of the following measures:

- Reorient or relocate the receiving antenna.
- Increase the separation between the equipment and receiver.
- Connect the equipment into an outlet on a circuit different from that to which the receiver is connected.
- Consult the dealer or an experienced radio/TV technician for help.

This transmitter must not be co-located or operating in conjunction with any other antenna or transmitter.

The device has been evaluated to meet general RF exposure requirement. The device can be used in portable exposure condition without restriction.