

Air Purifier Use and Care Guide

Model: P550

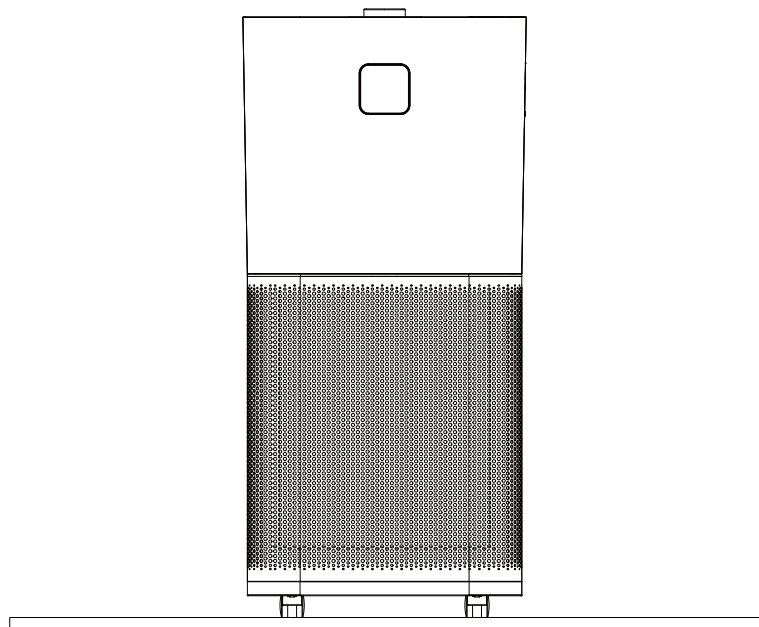

Table of Contents

Table of Contents

Product Components ----- 1

Operating instructions ----- 4

Care and Cleaning ----- 9

Notices ----- 10

Troubleshooting ----- 13

Technical specifications ----- 14

- Carefully read and understand the information given in this manual.
- Our company reserves all rights to interpret this instruction manual.
- The actual appearance is based on the object.
- IM should be well kept after reading together with invoice.
- Product technology or software upgrades are available without prior notice.

Product Components

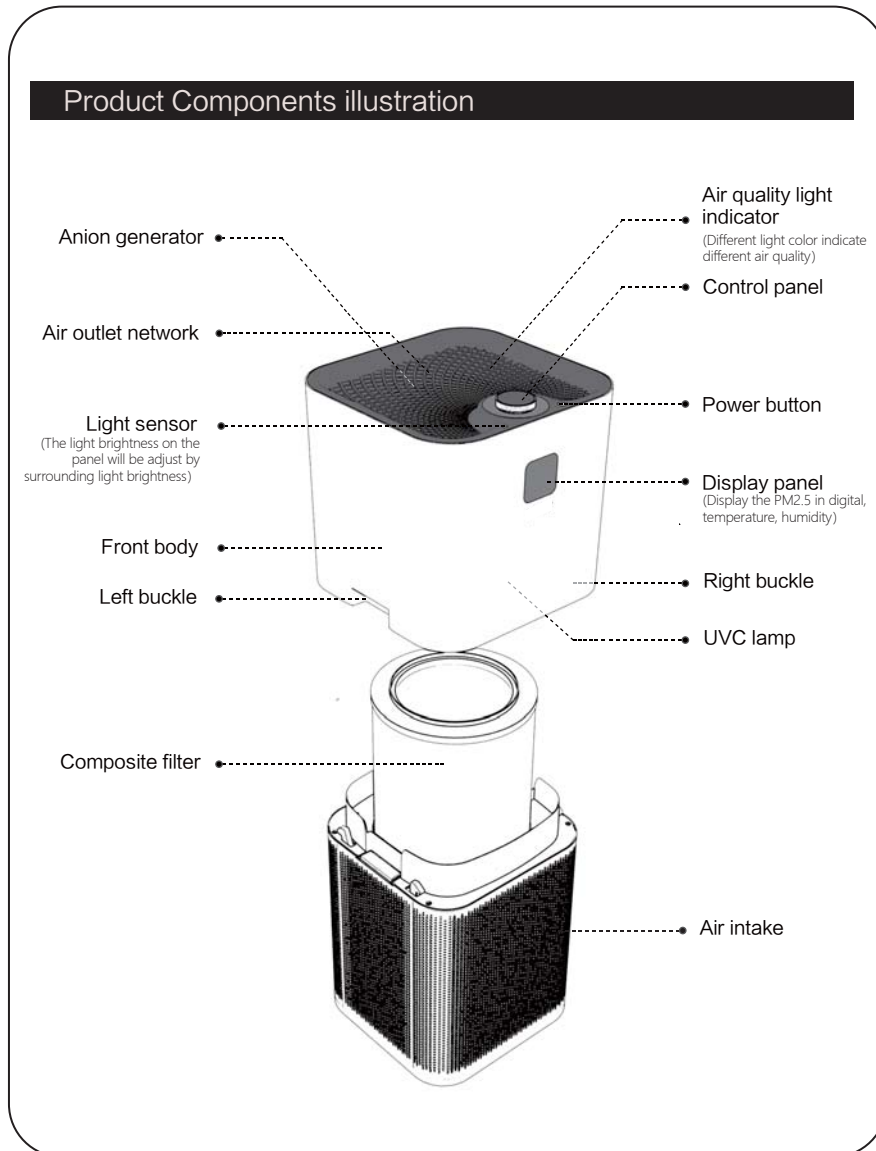

Product components

Purification principle and characteristic



- High efficient purification of PM2.5, smog, pollen and other particulate pollutants
- Formaldehyde removal
- 3 wind speed design
- Time set
- Filter change indicate
- Manual-operate mode, auto mode, sleep mode
- Temperature and humidity sense monitor
- Child lock
- PM2.5 value real-time display
- Wifi control
- UV

Purification technique

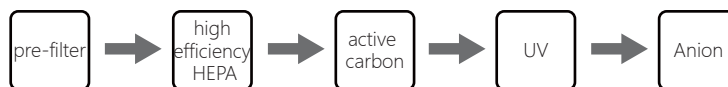

Composite filter

Pre-filter: Filter the contaminants of more than 20 micros, such as hair, dander, fiber and so on.
High efficiency HEPA: Filter particles of more than 0.1 microns in diameter, such as pollen, dust mites and other allergic gases.

Active carbon: Clear and remove volatile organic compounds, such as secondhand smoke, CO, formaldehyde, benzene, helium, TVOC and other harmful gases and so on negative.

UV Lamp

The built-in UV C-band LED disinfection lamp and irradiates the filter and airflow to achieve targeted irradiation and disinfection of the passing airflow and the filter that intercepts small particles attached to pathogens. The C-band UV lamp can destroy the molecular structure of DNA or RNA in the cells of the pathogenic bacteria, let the bacterial cells die, and achieve the effect of disinfection and sterilization.

Anion generator

Release the neg anion amount of more than 6×10 pas/cm, to fresh the indoor air, and make people stay as in the forest.

Product Components

Filter changement

- ⊙ Machine power off and unplug.(Picture 1)
Notice: Press the power button to turn off the machine, machine will under standby mode. Unplug to cut the power.
- ⊙ Pull the upper parts. Put hands to the both side of the buckle, and press down the buckle to make the two parts flick, then pull up the upper parts. (Picture 2.3.4)
- ⊙ Ttake out the new filter with plastic film from the machine, remove all packaging then reload.(Picture 5.6)
- ⊙ Install the upper body back to the original position, ensure that the buckle is installed in place(Picture 6)

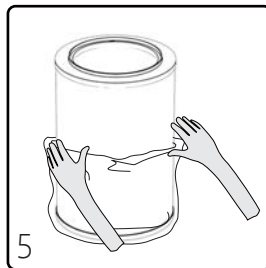
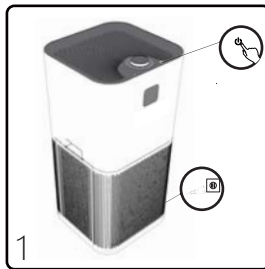

Notice: Please be sure to remove the outer package of the filter when first time using the machine.

Operating Instructions

Product operating Instructions

Machine will enter the standby mode after plug.



Power switch

Plug the machine to enter standby condition; press the power button to enter working condition; when machine in working condition, press the button to enter standby condition.



Filter reset

With the filter lifetime remain 48 hours left, filter reset light will flash red and remind user to change the filter.

a. After changing the filter, long press the "filter reset" till the red light stop flash



Time set

Touch the time set key in working condition, timing button and display lights up, and machine enter time set mode. Press the key once for 1 hour setting, press twice for 2 hour setting, and press one more time for one more hour setting. There are total seven hours setting, and when the lights off, it means to turn off the time set.



Anion

Touch the anion button to turn on the anion function. The built-in anion generator starts to release the anion. Touch the anion button again to turn off.



UVC

Touch the UVC button to turn on the UVC function. The built-in ultraviolet lamp starts to work to kill the bacteria and viruses in the filter and the airflow. Touch the UVC button again to turn off.

Operating Instructions

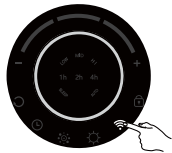

WiFi

Long pressed "WiFi" for 5 seconds to start the network match.

- The WiFi indicator lights flash white when matching the network
- The WiFi indicator will be white when the matching is done
- Long press the "WiFi" key again for 5 seconds to reset the WiFi

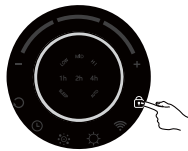

Child lock

Long press the child lock for 3 seconds in working condition, child lock key lights, and no key is functional during this period. Long press the child lock 3 seconds again to unlock it, child lock lights off, and all the key back to functional again.

Rotate the button clockwise or anticlockwise, there will be sleep mode, low speed, medium speed, high speed, auto mode changed cyclical.



Sleep

Rotate the button clockwise or anticlockwise, sleep indicator light on and enter the sleep mode. Turn off the sleep indicator light to close sleep mode.

- Sleep indicator light on under sleep mode
- All the other indicator light will be off under sleep mode, including the front panel display and the air quality indicator light.



Auto

Rotate the button clockwise or anticlockwise, the auto indicator light on to enter auto mode, the auto indicator light off to close auto mode.

- Auto mode will be started when turn on the machine
- Fan speed will be auto adjusted with the air quality around under auto mode, and the fan speed indicator light will be also auto adjusted.

Operating Instructions



Rotate the button clockwise or anticlockwise to set the fan speed. There are low speed, medium speed and high speed for user to choose.

a. The correspond fan speed indicator light will be on according to the real-time fan speed.



Low speed



Medium speed



High speed

Operating Instructions

Control panel and display

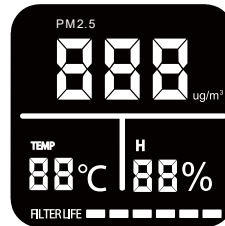

Instructions of panel display

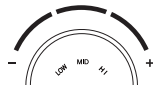

Fan speed display Rotate the knob to set the fan speed, clockwise from low to high, and anticlockwise from high to low. The fan speed light indicator will change with the fan speed, low speed shows in one block, medium speed shows in 2 blocks, high speed shows in 3 blocks. The low, medium, high will also be lighted at the different fan speed.

1h 2h 4h

Time set The related light will be lighted base on different time set. (please refer to page 6 for details)



Function display Rotate the knob to choose the different function, and the related lights on.

PM2.5
888
ug/m³

PM2.5 Display the PM2.5 value in real-time.

TEMP
28°C

Temperature display Display the temperature in real-time.

H
88%

Humidity display Display the humidity in real-time.

FILTER LIFE ■■■■■■

Filter lifetime With the filter lifetime reduced gradually, each one block dropped with each 500 hours used. One block stands for 500hours using time.

Air quality value and indicate light

| Air quality inspection will be turn on automatically with machine working normally | | | |
|--|-----------|--------|-----------|
| Air quality | Excellent | Good | Poor |
| Colors of air quality indicate light | Green | Blue | Red |
| Air quality digital display | 1-75 | 76-150 | above 150 |

Operating Instructions

Filter changement

- ⊙ Machine power off and unplug.(Picture 1)
Notice: Press the power button to turn off the machine, machine will under standby mode. Unplug the machine to cut the power.
- ⊙ Pull the upper parts. Put hands to the both side of the buckle, and press down the buckle to make the two parts flick, then pull up the upper parts.(Picture 2.3.4)
- ⊙ Take out the new filter with plastic film from the machine, remove all packaging then reload. (Picture 5.6)
- ⊙ Install the upper body back to the original position, ensure that the buckle is installed in place (Picture 6)

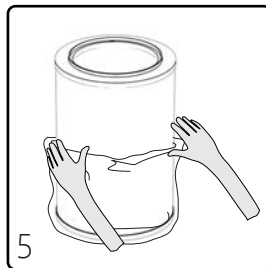
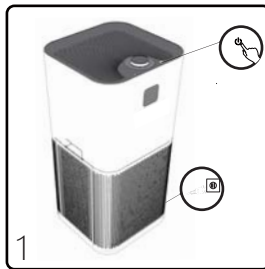

Notice: Please be sure to remove the outer package of the filter when first time using the machine.

Care and Cleaning

Care and Cleaning

Machine must unplug before care and cleaning

1. Clean the machine

- 1) Wipe the stains with soft cloth.
- 2) For the Stubborn stains that hard to clean, please dip some neutral onto the soft cloth then clean.

Notice: No hard object to scratch the machine surface during care and clean. When tear down the machine, please refer to the instruction manual and do as the requirement to avoid damaging the components.

2. Filter clean and change

- 1) The build-in program will remind to change the filter. Due to different air quality around and the filter life time will also different. User change the filter can also judge from the machine noise and the smell.
- 2) If there are dust cover on the composite filter, vacuum cleaner can be used to clean the dust on the surface, to extend the lifetime of the filter. (Advise to clean once a month)

| | Change frequency | Condition |
|------------------|-------------------------------|--|
| Composite filter | Change the filter once a year | Absorb the emissions of about 3 cigarettes per day |

1. The filter change time will be shorten for the different place and different using method (Such as the place where many people smokes). Please change the filter in time when purify effect is not good.
2. Please dispose the used filter as Non-combustible garbage.

Notices



Notes:

All the items are related with the safety and please obey as below.

The goal of below notice is for user to use machine correctly.

There explains the dangers, danger lever and the accident that may occurs in below notice item.

1. Please do not use other components that not permitted by manufacturer, and warranty will be terminated if machine breakdown in that case.
2. Please check whether machine is fine and whether spare parts are complete after unfold the package.
3. Children and the Incapacitated person should use the machine accompany with their superintendent,
4. Please unplug the machine immediately if accident occurs, and please do not use the machine under defect condition.
5. In order to avoide the danger, if supply cord damaged, they can only be changed by the manufacturer or the qualified maintenance person.

| | |
|--|---|
|  Firbidden marks | All the contents with this mark are forbidden behaviour, otherwise it will lead to the machine damaged or user harmed. |
|  Warring marks | All the contents with this mark, user should operate as it required, otherwise it will lead to the machine damaged or user harmed. |
|  Notice mark | All the contents with this mark, user must pay more attention to them, otherwise there will be machine damaged or other harmed due to improper operation. |















Please do not put your hands or foreign matter into the air inlet and the air outlet









Please do not unplug the power with wet hands

Notices

| | |
|---|--|
|  <p>Please do not use the air purifier at the place where full of hydrogen, natural gas, dimethylmethane and some other inflammable gas.</p> |  <p>Please do not use the air purifier if power cord or plug damaged, or power socket slack off.</p> |
|  <p>Please do not use the air purifier when using the aerosol bomb, or there are oil residue, incense' smoke, a light flame, Chemical odor in the room. Also do not use the air purifier in the deep wet place such as in the shower room.</p> |  <p>Please do not jam the air inlet and air outlet.</p> |
|  <p>Please do not operate the air purifier without filter inside.</p> |  <p>Please do not wash or re-use the composite filter.</p> |
|  <p>Only 220V voltage socket can be used.</p> |  <p>Please hold still the plug when unplug, and do not pull the power cord, otherwise it will cause electric shock or the fire disaster of short out.</p> |
|  <p>Please unplug the machine when machine not in use or need clean, otherwise it will cause electric shock of low insulation or the fire disaster of short out.</p> |  <p>Please clean the dust on the plug regularly.</p> |
|  <p>Pls do not use the strong causticity detergent when cleaning the machine, as they will damage the surface of the air purifier.</p> |  <p>Only soft cloth can be used to clean the surface of the machine, otherwise the machine may be damaged or fractured.</p> |

Notices

| | |
|---|---|
|  <p>When using the machine, do not put it close to the the heat source object or put onto it.(Such as the fireplace or the stove or the place where can get touch with the Inflammable gases)</p> |  <p>Ethyl alcohol or organic solvent are forbidden to be used to wipe the machine, otherwise it will damage the machine or lead to electric shork or fire disaster.</p> |
|  <p>This symbol represent for, there are possiblity of injury or physical damage.</p> |  <p>User can directly push the machine or hands hold on both sides of the buckle to move the machine. If user hold the air outlet to move the machine, it is possible to make the air outlet or the host machine fall off,which will cause the human injury.</p> |
|  <p>If the air purifier cause signal interference on the radio or the television, please try the adjust measure one or more items as below:</p> <ol style="list-style-type: none"> 1. Re-adjust or rotate the receiving antenna. 2. Take the air purifier far away form the radio/televi-sion singal receiver. 3. Connect the the air purifier power and the singal power on different socket. 4. Please contact the manufacturer or the qulified radio/television man if assistance needed. |  <p>This machine do not suit for the disabilities person, perceptually handicapped, Mentally handicapped or child operate by themselves except there are guardians or safety director on the spot to guide or assist operate.</p> |

Trouble shooting

Trouble shooting

| Problem | Possible cause and solution |
|---|--|
| Machine can not start up | <ol style="list-style-type: none"> 1. Machine haven't plug well; need to re-plug. 2. Check whether the front panel installed properly. |
| Small air flow from air outlet | <ol style="list-style-type: none"> 1. Filter package have not been removed; remove the package and re-install the filter 2. There are foriegn matters jam the air inlet or air outlet;clear up the foreign matters. 3. The filter is too dirty, clean the filter or change the filter. |
| Dust remval effect is not obvious and air quality have not get better obviously | <ol style="list-style-type: none"> 1. No filter in the machine; install the filter into the machine. 2. The door or window in the room are opened too often to let the dirty air flow into room.The air flow slow indoor, and longer time needed to purify the air indoor. 3. Machine is put in narrow place or there are barrier around, which will effect the purify efficiency 4. Filter dirty and will effect the purify efficiency;advise to clean the filter or change a new filter. |
| Odors from the air outlet | <ol style="list-style-type: none"> 1. Many people smoke or barbecue or do something others in the room that cause odor in the room; advise to change the indoor air 2. Filter seriously dirty; advise to change a new filter |

Notice: Please do not tear down the machine by yourself,in case that will cause danger or damage to mahcine.

Technical specifications

Technical parameters

| | | | |
|--------------------|--------------|------------------------------|------------|
| Product Name | Air Purifier | Product model | P550 |
| Rated voltage | 120V~ | Rated frequency | 60Hz |
| Rated input power | 70W | Noise | 35-61dB(A) |
| Particle CADR | | 350 CFM | |
| Available area | | 1100 ft ² (ACH=2) | |
| Product dimensions | | 13.8"(L)×13.4"(W)×29.5"(H) | |
| Net weight | 20.9 lbs. | Gross weight | 30.8 lbs. |

Technical specifications

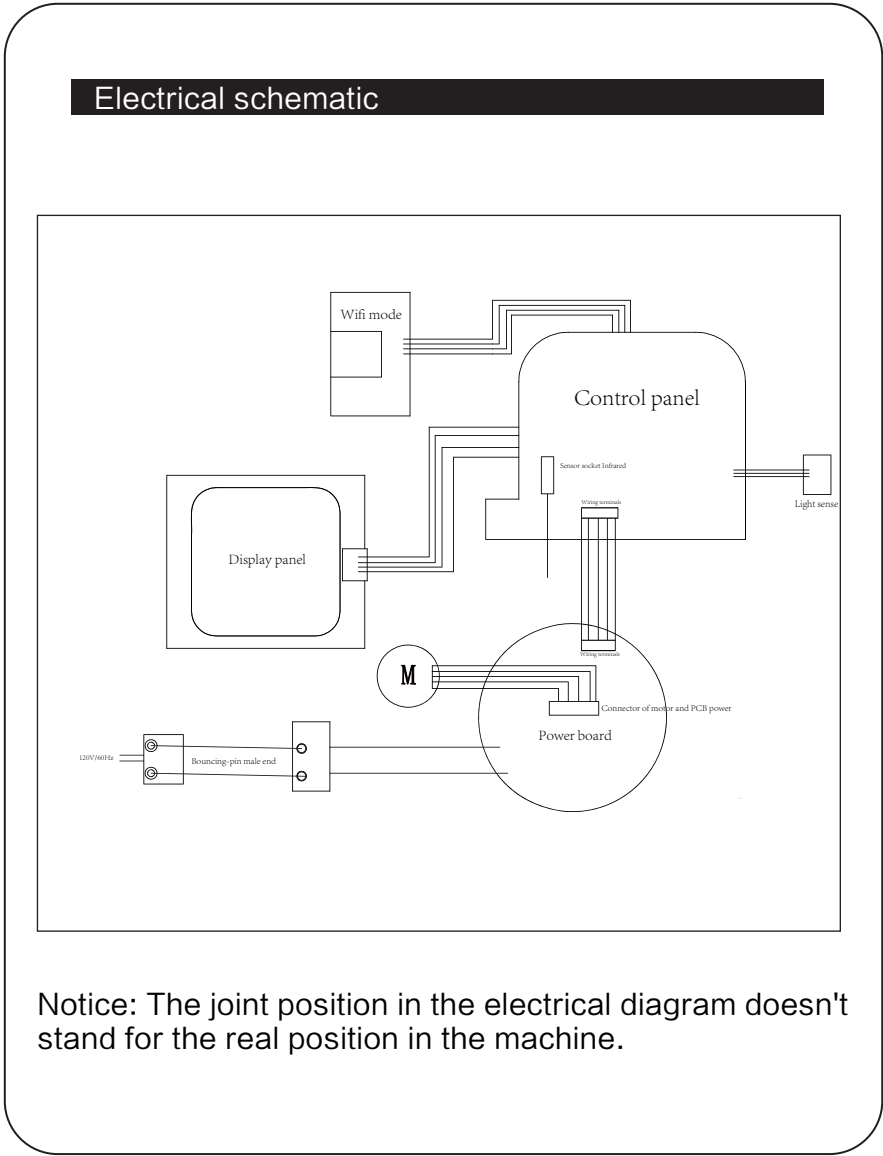

FCC Warning

This device complies with part 15 of the FCC Rules. Operation is subject to the following two conditions: (1) this device may not cause harmful interference, and (2) this device must accept any interference received, including interference that may cause undesired operation.

Any changes or modifications not expressly approved by the party responsible for compliance could void the user's authority to operate the equipment.

NOTE: This equipment has been tested and found to comply with the limits for a Class B digital device, pursuant to Part 15 of the FCC Rules. These limits are designed to provide reasonable protection against harmful interference in a residential installation. This equipment generates, uses and can radiate radio frequency energy and, if not installed and used in accordance with the instructions, may cause harmful interference to radio communications. However, there is no guarantee that interference will not occur in a particular installation. If this equipment does cause harmful interference to radio or television reception, which can be determined by turning the equipment off and on, the user is encouraged to try to correct the interference by one or more of the following measures:

- Reorient or relocate the receiving antenna.
 - Increase the separation between the equipment and receiver.
 - Connect the equipment into an outlet on a circuit different from that to which the receiver is connected.
 - Consult the dealer or an experienced radio/TV technician for help.
- To maintain compliance with FCC's RF Exposure guidelines, This equipment should be installed and operated with minimum distance between 20cm the radiator your body: Use only the supplied antenna.