

USER MANUAL

For more details,
please consult online
customer service.



Please read this user manual carefully before use.

Important Safety Notes

For the best viewing effect, please use the projector in dark room.

1. Do not install this projector in the area which directly blown by the air conditioner, to prevent projector failed caused by water vapor condensation or excessive temperature.
2. Ensure that the environment is ventilated to prevent overheat caused by heats build-up.
3. Prevent foreign objects from falling into the machine. Never insert any metal objects into the machine. If foreign objects fall into the machine accidentally, please power off immediately and seek professional assistance.
4. Do not place any liquid on the machine to avoid leakage.
5. Avoid violent vibrations when transporting. Please protect the lens from wear.
6. Do not touch the vents when using the projector to avoid burns due to excessive temperature.
7. Do not look directly at the lens while the projector is running to prevent eye injury.
8. Please clean the filter regularly to prevent malfunction caused by clogging.

Notice

Do not open the case of projector to prevent electric shock. Please seek professional assistance for maintenance matters.

Warn

Do not touch! The inside of the projector contains uninsulated voltage.

Warn

Do not install the projector around flammable objects to prevent fire.

Important Safety Notes

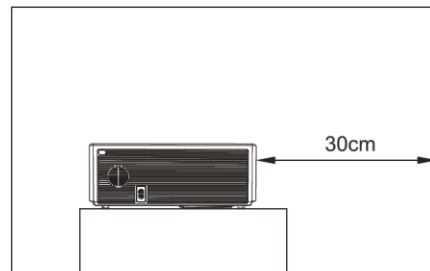
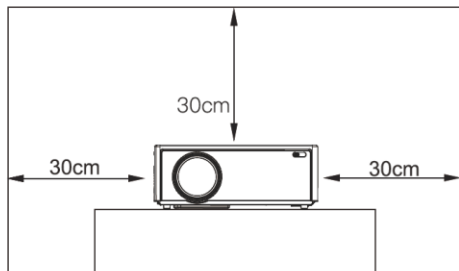

To ensure the performance and stability of the projector, please place it horizontally and leave a space of about 30cm between the projector and the wall.

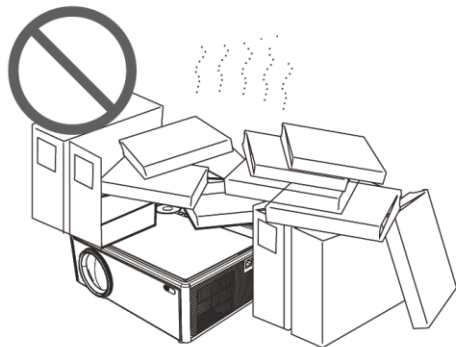

Do not install in place with poor ventilation.

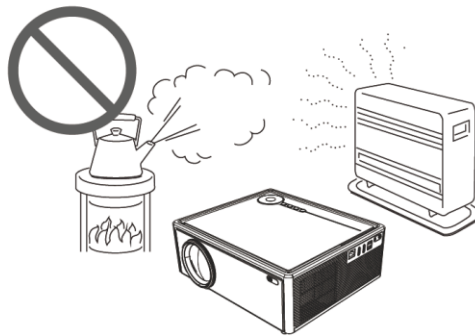

Do not install in high temperature or humid places.

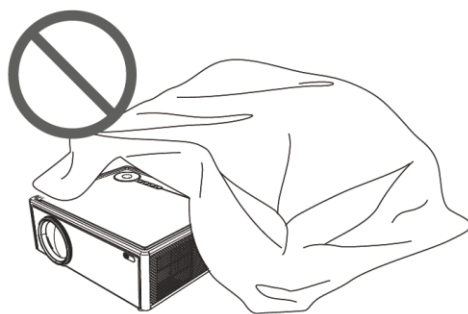

Do not block the vents

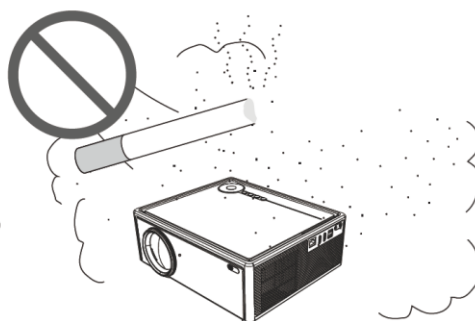

Do not install in dust or smoky places

Specifications

Item	Specification	
Product	X7	
Brightness	600 ANSI	
Native Resolution	1920×1080	
Video	Support 8K/4K Decoding	
Audio	Dual Stereo Speakers, Support Dolby Audio	
System	Android 9.0 OS, OTA Upgrade Support	
CPU+GPU	Amlogic T972 + ARM Mali-G31 MP2	
WiFi	Dual Band WiFi 2.4/5GHz	
BT	BT 5.0	
Ethernet	100Mbps	
Interface	HDMI	HDMI IN*2
	USB	USB 2.0 Port*2
	Earphone	3.5mm Earphone*1
	AV	AV IN*1
	LAN	LAN IN*1
Environment		
Power Input	AC 110–240V 50~60HZ	
Operating Temperature	0 ~ 40°C	
Storage Temperature	-20 ~ 65°C	
Operating Humidity	0 ~ 90% Non-condensing	

1 Package Contents



Projector



Power Cable



Voice Remote



Heightening Screw



HD Cable



User Manual

Projector Introduction

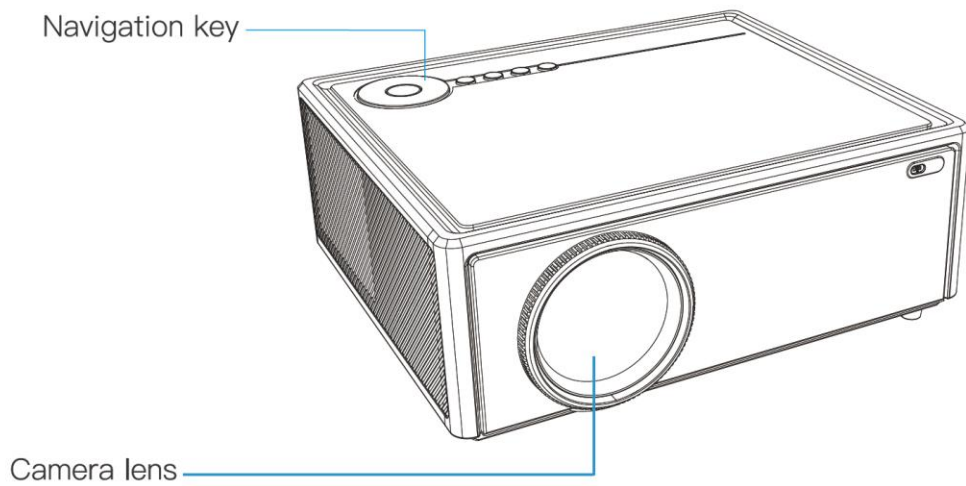
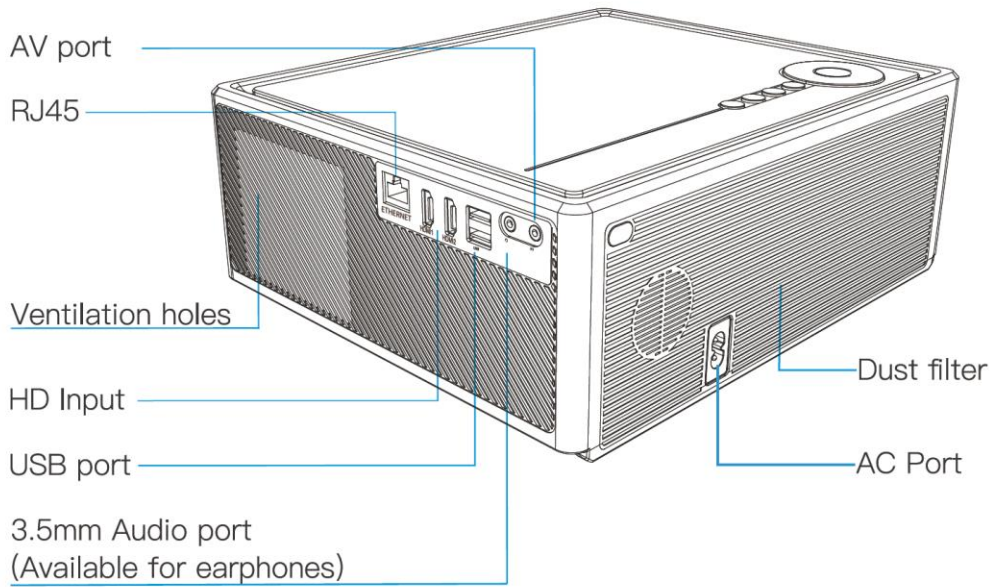

💡 All the key presses described in this document are available on the remote controller or projector.

Infrared Signal Indicator LED

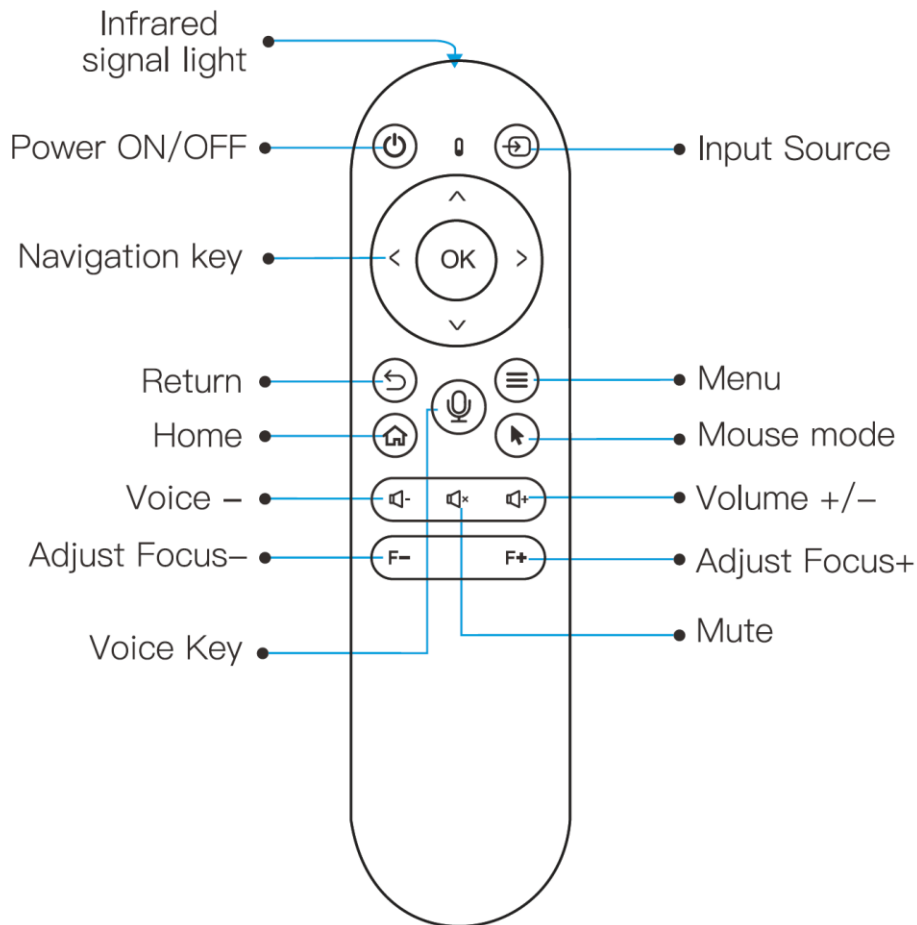

Pairing method(Bluetooth mode connection)

1. Select [Settings] > [Bluetooth & Remotes]> [Add accessory].
2. Press and hold the left & right direction buttons at the same time for 3–5 seconds until the red light flashes.
3. Select the name [Bluetooth remote] of the list to connect.
4. After pairing, you can now use the voice button to search for what you want.

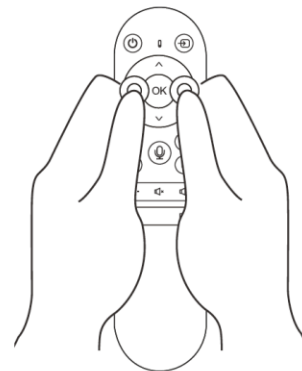

Projection Size/ Distance Reference

The projection screen size (or size of images) is determined by the distance between the lens of the projector and the projection surface.

- The projection image size is up to **120"**
- The projection distance is **4.1ft – 13ft**

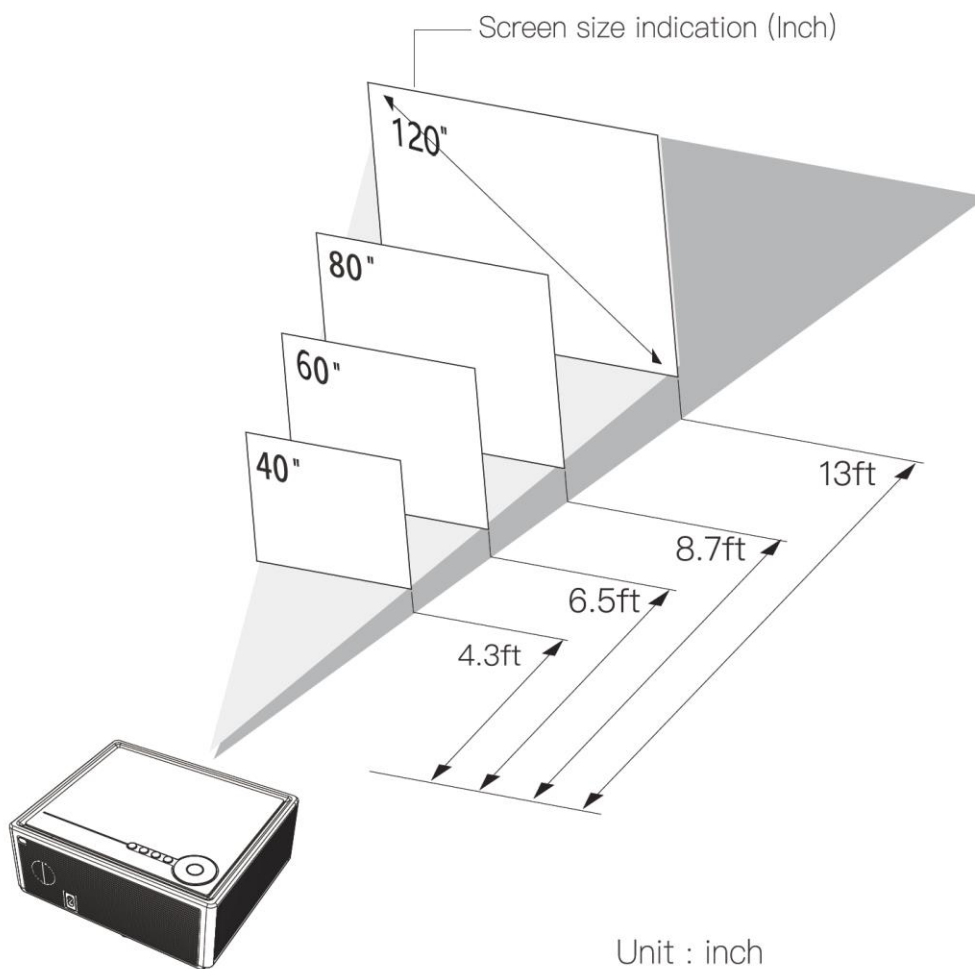

Unit : inch
Data for reference only

Power- On/Off Operation

1 Power Connection

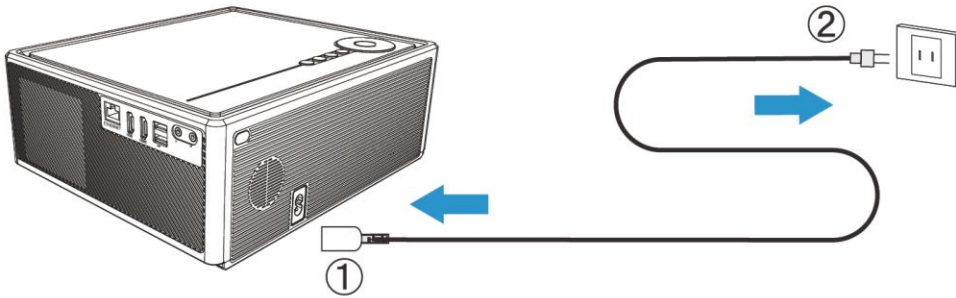

Connect the included power on the projector, and then to the wall outlet.

2 Power On&Power Off

Press the power button to boot up projector.

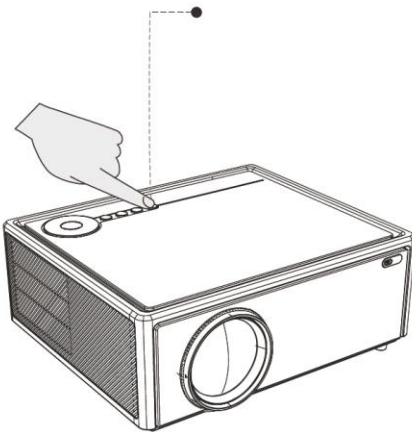

Way1:
Power on/off by the button on projector.

Aim the remote controller at the receiver sensor part of the projector.

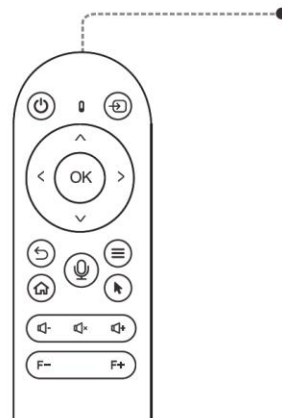

Way2:
Power on/off by remote control.

Screen Adjustment

Adjust the size and position of the picture by adjusting the projection angle (height of the image), tilting the image left and right, adjusting the focus, zoom out/zoom in the image size, adjusting the keystone correction.

1 Adjust the Height Screw

1. Raise the front of the projector.
2. Screw on the heightening screw to adjust the picture to the height you want.

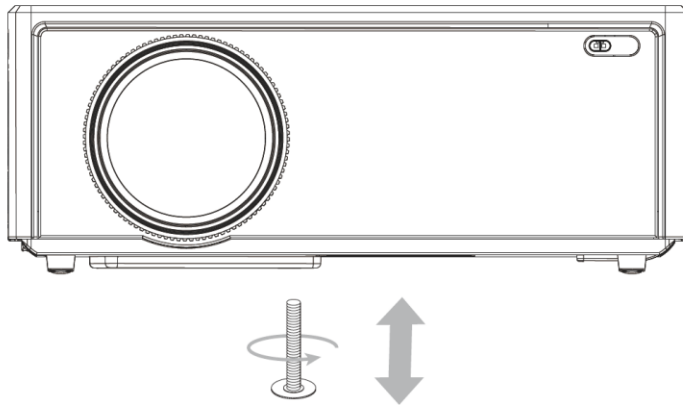

2 Auto Focus

After the first startup, the focus will be automatically completed. Long press F+/F- button of remote control to control the lens for fine tuning.

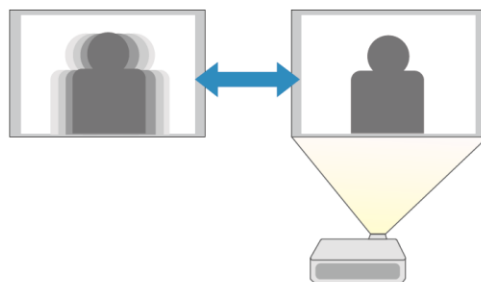

Screen Adjustment

3 Projection Methods

Depending on the installation method, select the appropriate option in the settings.

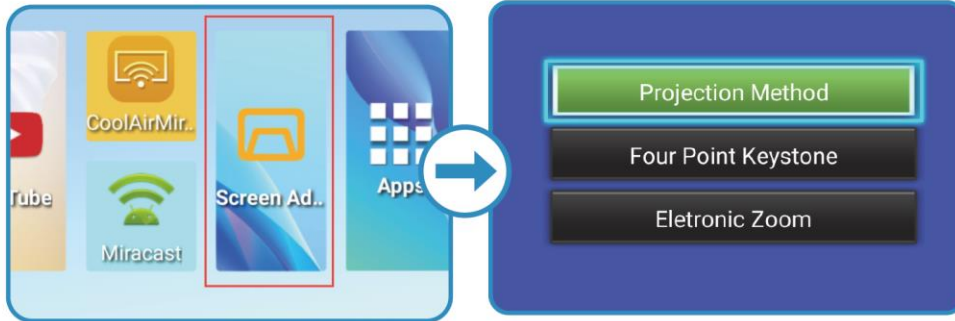

1: Frontal projection

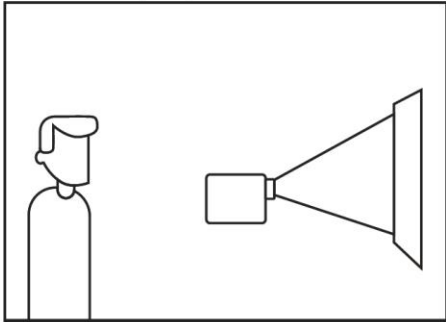

2: Hanging projection

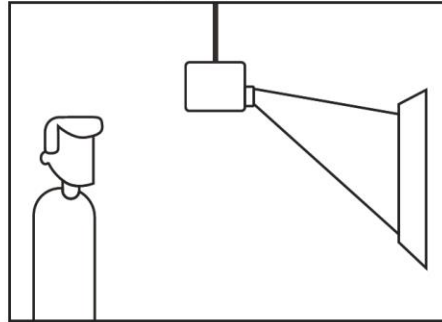

3: Rear projection

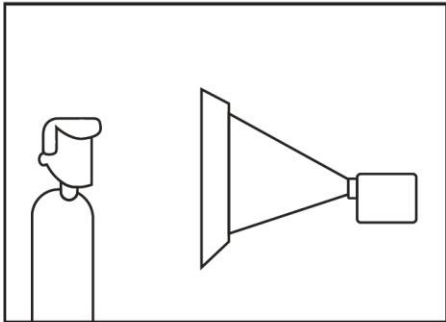

4: Rear hanging projection

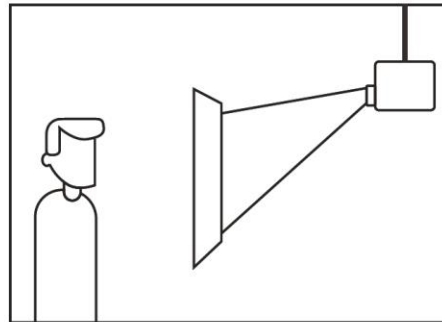

Screen Adjustment

4 Auto & Manual Keystone Correction

Automatic Keystone Correction Enable is off by default.

How to make it work:

Settings > Auto Focus & Auto Keystone> Turn on the switch for automatic Keystone Correction.

Manual Keystone Correction:

Go to Settings and then adjust it according to the projected image.

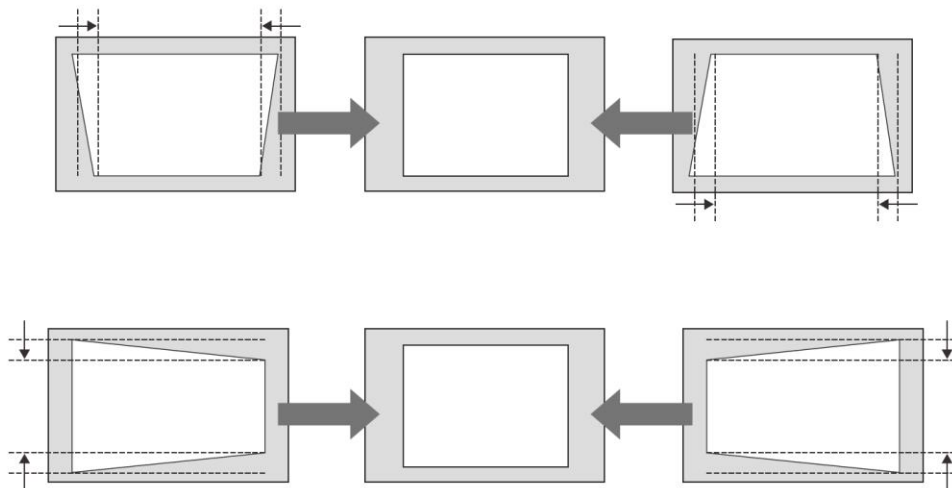

Screen Adjustment

5 Eletronic Zoom

No more space constraints, no need to change the projector distance, just move the projector to fit the screen size, you can customize your projection screen size from 50% to100%.

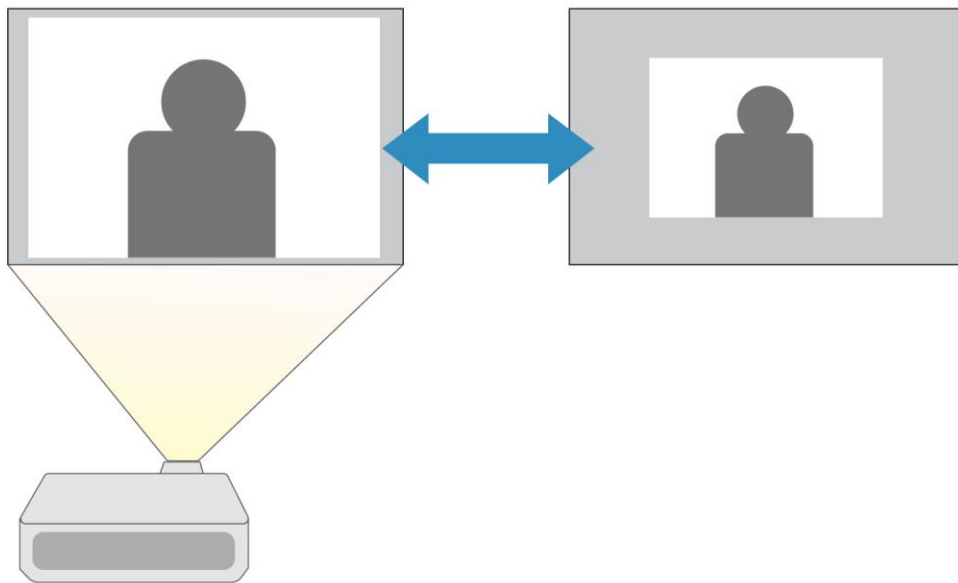
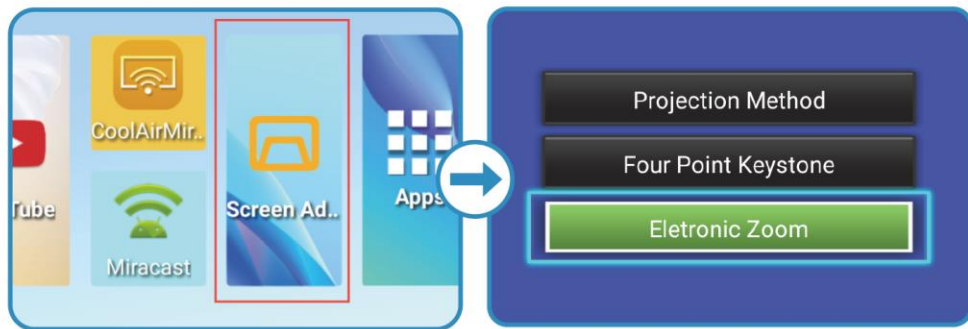

Screen Adjustment

5 Brightness Adjustment

When playing a video, you can set the picture mode.

1. Set picture mode

Press [Settings] button on the remote, open [picture], click [picture mode], select the picture mode you want.

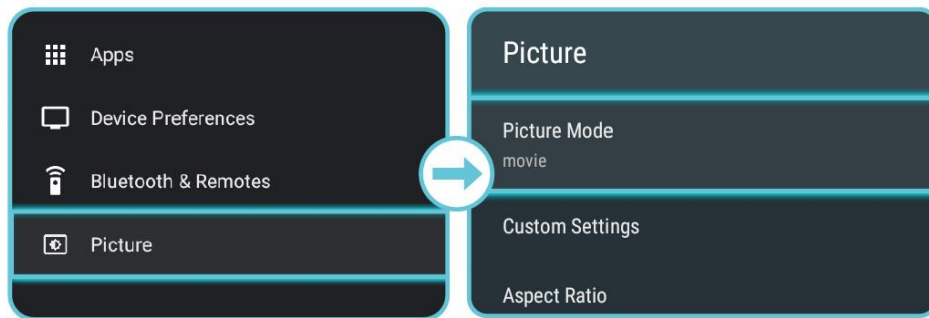

2. Custom picture mode:

Select [Settings] > [Picture] > [Custom Settings], adjust the parameters as needed.

 **Remember to take pictures and record the original values before modifying parameters.**

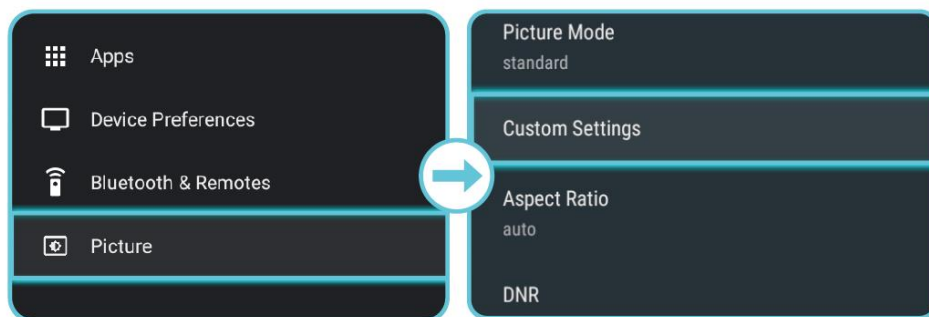

System Initial Setup

1 Language Select

Select [Settings], open [Device Preferences], click [Language], choose your preferred language.

2 Date & Time

Select [Settings], open [Device Preferences], click [Date & time], then you can access to [Set time zone] and [Use 24-hour format].

3 Network

1. Select [Settings], click [Network & Wi-Fi] to access to the Wi-Fi settings page.
2. Choose the Wi-Fi option and enter passwords to connect.

4 FOTA Update Online

Select [Apps], open [FOTA update], click [Check Version], follow the screen instructions to upgrade the software version.

System Initial Setup

5 Bluetooth Connection

A. Projector Mode

Connect projector to a Bluetooth speaker, Bluetooth headphone, Bluetooth remote, etc.

- ① Turn on your device's Bluetooth
- ② Select [Settings]> [Bluetooth & Remotes]>[Add accessory],turn on your devices Bluetooth and choose the name of your device to complete the Bluetooth connection.

B. Bluetooth Speaker Mode

Use the projector's speakers to output audio from a compatible device connected by Bluetooth, such as Smart phone, Laptop,etc.

- ① Open [Apps], open [Bluetooth Speaker] to switch to Bluetooth speaker mode.
- ② Enable Bluetooth on your smartphone and select [ZH_X7] as the devices to be added.
- ③ Play the music you want.
- ④ Press the [Return] button on the remote controller to exit this mode.

System Initial Setup

6 Apps

Once connected to a wireless network, you can access online services, enjoy movies, music and pictures, and browse internet. Apart from the apps installed, you can also install any other apps either from the App Store or by a USB flash drive.

Installed Apps, like Netflix, TikTok, YouTube, Chrome, PrimeVideo, WPS office, etc.

💡 **When open Netflix at the first time, there is notice popup reminding customer to update, please click "CANCEL", DO NOT update. (Installed Netflix is very stable, so up dating is not recommended).**

App Manager

① Press [Home] button >select [Settings] >[Apps] >[See all apps] and press [OK].

② Select an app and check the current version, open or forces-top, check the storage used or clear data, or clear cache, or clear default, or uninstall it.

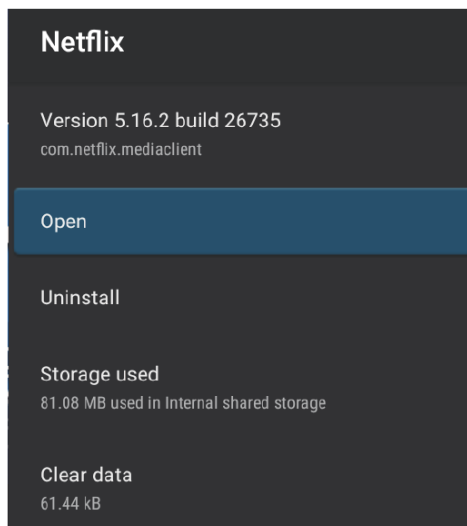

Select the Input Source

1 Connect to HDMI/AV Playback Devices

This device supports connections with various HD/AV playback devices such as streaming media player, TV stick, TV box, DVD player, set-top box(STB), game machine or other devices(HD cable provided).

① Connect this device to an HD/AV playback device with an HDMI/AV cable.

② Press [Input Source] key or Select [Signal Source] to access the menu, then select the source channel you need.

💡 **Press [Menu] on the remote control, you can set parameters of the picture for Signal Source.**

💡 **It can be set to stay on the previous input source after you reboot this device.**

2 Connect to USB Storage Device

With this device, you can enjoy music, video, and picture, or install apps that are stored on a USB storage device.

① Press [Home] button to access the home menu.

② Select File Manager app and press [OK].

③ Select a file, then press [OK].

Screen Mirroring

You can wireless cast the screen of your smart phone or tablet onto the projection surface.

1 For iOS Devices:

- ① Ensure the iOS device and projector connected to the same network.
- ② Select and open [iOS Cast] on the home page.
- ③ Open the Screen Mirroring from the control center on iOS Devices.
- ④ Search for available devices.
- ⑤ Connect to [Bytefly-xxxxxx] option to start mirroring screen.

2 For Android Devices:

- ① Select and open [Miracast] on the home page.
- ② Open the Wireless Cast on Miracast-compatible device to search available devices, select the [ZH_X7] option to connect.
- ③ Accept the connection invitation from the device. If the screen is synchronized, means screencast completed.

3 For Windows Laptop(Win 8.1/10/11)

- ① Select [Cast] on home page > open [Miracast].
- ② Press the Windows key and P key on your keyboard at the same time > [Project] > Select Connect to a wireless display.

Screen Mirroring

⚠ If the Connect to a wireless display option is not listed, this means your device or video card does not support Miracast.

③ A scan for wireless display devices will start. Select your desired wireless display device named [ZH_X7].

④ Once connected, your Windows 10 device should now be mirrored by the wireless display.

💡 Certain content may be unavailable to be casted due to copyright restrictions. In this case, you can stream those content via the same app installed in your projector.

Maintenance Suggestion

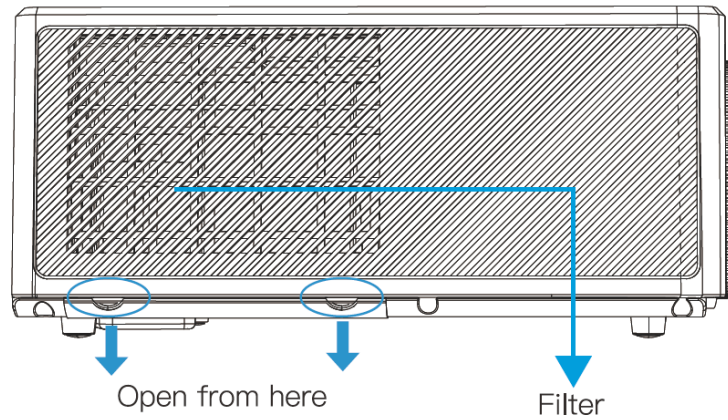

Notice

To make this projector work longer, we recommend you to follow the suggestions.

1. Before cleaning the projector, turn off the projector, then turn off main power and unplug it from the outlet.
2. Clean the filter regularly every month to prevent clogging.
3. Make sure to close the projector off once you finished using it.
4. Make sure not to use it continuously for more than 6 hours.

Troubleshooting

1 Unable to Boot Up

* Check if the power cord is connected properly, and if the power light is on. Try to unplug and plug the power if the projector still can not boot up.

2 Remote Controller is Insensitive or Unresponsive

- * Do not cover IR receiver.
- * In the infrared mode, make sure remote points at IR receiver directly.
- * There is an obstacle between the remote control and the projector.
- * The batteries are out of power or the battery is not installed correctly.
- * Pair the Bluetooth remote control and make sure is working within 5 meters.

3 No Network Connection

- * WiFi is not connected properly, or the WiFi signal is poor.
- * Please connect hotspot of smart phone to verify if router is working properly.

4 No Network Connection

- * The connection cables are not securely connected to the projector or the signal source.
- * The Internet bandwidth is limited or over-occupied.
- * The projector is out of effective range of Bluetooth connection.

Troubleshooting

5 No Input Source

- * The video source is not turned on or connected correctly.
- * The projector is not correctly connected to the input source device.
- * The video or audio file format is not supported by the projector.

6 Computer Can't Display Through HD Cable

- * HD cable not securely connected.
- * Try to turn off HD 2.0.

7 Black Screen or Abnormal Picture After Booting for a While

- * Make sure the power plug is working and firmly fitted into the outlet.
- * Reboot the projector.
- * The vents are blocked (Cleaning every three months is recommended).
- * Cooling fan is not working properly. If abnormal, please return for repair.

8 Blurry Display

- * The lens is not clean.
- * The projection lens is not correctly focused.
- * The projector and the screen are not aligned properly.
- * The environment is too bright.

9 Screen Freeze

- * Please reboot the projector to test again. If the screen still freeze, please turn off for 10 minutes and turn on again.

If you have any other problems or suggestions, please contact our online services to help you immediately.

Warranty Card

1. This projector supports Three Guarantees Service Warranty for 1 year from the date of purchase(non—artificial damage).
2. Within warranty, we support warranty service for any failures caused by product technology.
3. The following situations are not covered by the warranty:
 - * Accessories except the projector.
 - * Products that have been disassembled and repaired without permission.
 - * Damage caused by external force and other natural disasters.
- 4 . When the product fails, please contact the dealer or supplier in time to arrange for repair with this warranty card.
5. This warranty liability is limited to product failure repairs within the warranty period.

FCC Statement

This equipment has been tested and found to comply with the limits for a Class B digital device, pursuant to Part 15 of the FCC Rules. These limits are designed to provide reasonable protection against harmful interference in a residential installation. This equipment generates uses and can radiate radio frequency energy and, if not installed and used in accordance with the instructions, may cause harmful interference to radio communications. However, there is no guarantee that interference will not occur in a particular installation. If this equipment does cause harmful interference to radio or television reception, which can be determined by turning the equipment off and on, the user is encouraged to try to correct the interference by one or more of the following measures:

- Reorient or relocate the receiving antenna.
- Increase the separation between the equipment and receiver.
- Connect the equipment into an outlet on a circuit different from that to which the receiver is connected.
- Consult the dealer or an experienced radio/TV technician for help.

This device complies with part 15 of the FCC Rules. Operation is subject to the following two conditions:

(1) This device may not cause harmful interference, and (2) this device must accept any interference received, including interference that may cause undesired operation.

Changes or modifications not expressly approved by the party responsible for compliance could void the user's authority to operate the equipment.

This equipment complies with FCC radiation exposure limits set forth for an uncontrolled environment.

This equipment should be installed and operated with minimum distance 20cm between the radiator & your body.

Warranty Card

Client Name: _____ Client ID: _____

Client Phone Number: _____

Purchase shop: _____

Return Address: _____

Fault description:
(For quick repair, please describe the problem in details.)