

# ANTENNA SPECIFICATION0

CUS P/N : T2970  
CREDITS P/N :

ApplicationDate: 2022-12-9  
Editor:

Rev: R:A0  
Page 1 of 7

## Index

1.		<b>General Description</b>	1
2.		<b>Electrical Specifications</b>	2
	2-1	<b>Set-up</b>	2
		2-1-1 <i>Frequency Band</i>	2
		2-1-2 <i>Impedance</i>	2
		2-1-3 <i>Matching Requirements</i>	2
		2-1-4 <i>VSWR</i>	2
	2-2	<b>Test Data</b>	3to4
		2-2-1 <i>VSWR</i>	3
		2-2-2 <i>TRP&amp;TIS</i>	4
3.		<b>Mechanical Specification</b>	5to7
	3-1	<b>Mechanical Configuration</b>	5
		3-1-1 <i>Mechanical Configuration</i>	5
		3-1-2 <i>Mechanical Configuration</i>	6
	3-2	<b>Measurement Data</b>	7
	3-3	<b>Salt-Spray Test</b>	7
4.		<b>Environment Characteristics</b>	7

# ANTENNA SPECIFICATION0

CUS P/N : T2970  
CREDITS P/N :

ApplicationDate: 2022-12-9  
Editor:

Rev: R:A0  
Page 2 of 7

## 1. General Description

This report summarizes the electrical performance results of the proposed Internal antenna to support the F12 (BT) program. The antenna is an assembly BT 2.4G.



## 2. Electrical Specifications

### 2-1 Set-up

#### 2-1-1 Frequency Band

Frequency Band	Tx(MHz)	Rx(MHz)
<b>2.4GHz</b>	<b>2400-2450-2500</b>	<b>2400-2450-2500</b>

#### 2-1-2 Impedance

Nominal Impedance(including matching circuit) : **50** ohms

#### 2-1-3 Matching Requirements

The matching circuit on the PCB of the handset is according to Figure 1

Optimum matching circuit is highly dependent on the handset and thus.

Final matching circuit layout and values will be defined when handset is available.

#### 2-1-4 VSWR And GAIN

VSWR			GAIN			
Freq. Band	OPEN	SPEC	Band	Freq.	OPEN	SPEC

# ANTENNA SPECIFICATION0

CUS P/N : T2970  
CREDITS P/N :

ApplicationDate: 2022-12-9  
Editor:

Rev: R:A0  
Page 3 of 7

2400MHz	$\leq 2.5$	2400MHz	$\geq -1.0\text{dBi}$
2450MHz	$\leq 2.0$	2450MHz	$\geq 0.5\text{dBi}$
2500MHz	$\leq 2.0$	2500MHz	$\geq -1.0\text{dBi}$

※Measuring a  $50\Omega$  test jig is connected to a network analyzer to measure the VSWR

※※All test value is done in customer approval fixture.

## 2-2 Test Data

### 2-2-1 BT VSWR

Model No:	<b>File:</b>
CREDITS NO:	Note:
Sample No:	BT-VSWR
Ant. Gain	1.0dBi Max.
Confirmation:	Engineer:

# ANTENNA SPECIFICATION0

CUS P/N : T2970  
 CREDITS P/N :

ApplicationDate: 2022-12-9  
 Editor:

Rev: R:A0  
 Page 4 of 7

## 2-2-2 BT GAIN&EFF

Passive Test For BT										
Freq (MHz)	Effi (%)	Effi (dB)	Gain (dBi)	Gain (dBd)	UHS (%)	DHS (%)	Max (dB)	Min (dB)	irectivity (dBi)	Beamwidth (3dB)
2400	38.15	-4.18	1	-1.15	16.755	21.397	1	-11.33	5.18	0
2410	37.93	-4.21	0.98	-1.17	16.611	21.323	0.98	-11.36	5.19	0
2420	36.91	-4.33	0.91	-1.24	16.003	20.912	0.91	-11.57	5.24	0
2430	35.46	-4.5	0.76	-1.39	15.253	20.212	0.76	-11.84	5.27	0
2440	35.09	-4.55	0.72	-1.43	15.089	20	0.72	-11.91	5.26	0
2450	34.57	-4.61	0.69	-1.46	14.837	19.732	0.69	-11.94	5.3	0
2460	33.34	-4.77	0.55	-1.6	14.206	19.138	0.55	-12.16	5.32	0
2470	33.25	-4.78	0.55	-1.6	14.145	19.101	0.55	-12.11	5.33	0
2480	32.71	-4.85	0.48	-1.67	13.964	18.746	0.48	-12.08	5.34	0
2490	31.93	-4.96	0.4	-1.75	13.566	18.364	0.4	-12.1	5.36	30
2500	32.01	-4.95	0.44	-1.71	13.496	18.512	0.44	-12.12	5.38	30

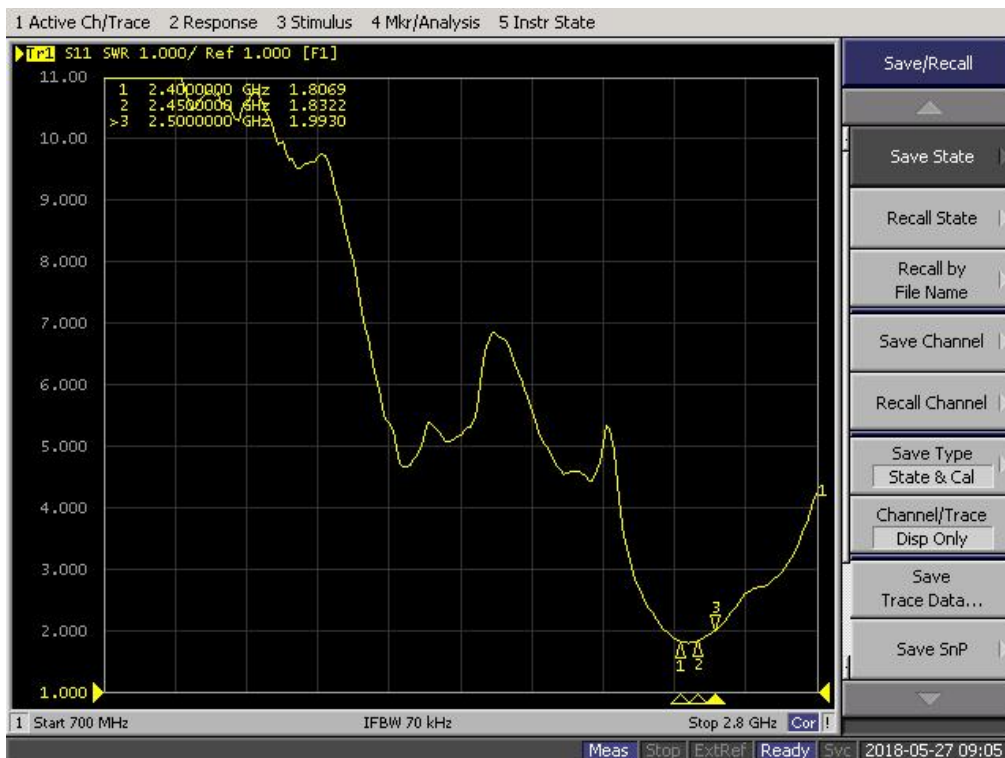

# ANTENNA SPECIFICATION0

CUS P/N : T2970  
CREDITS P/N :

ApplicationDate: 2022-12-9  
Editor:

Rev: R:A0  
Page 5 of 7

### 2400.000MHz

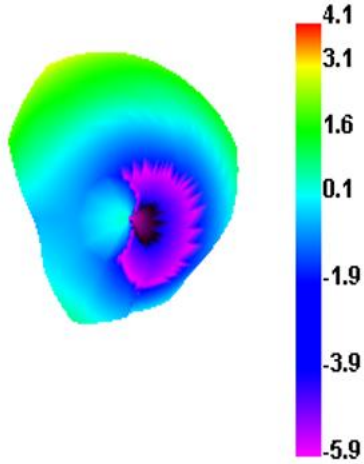

### 2400.000MHz H

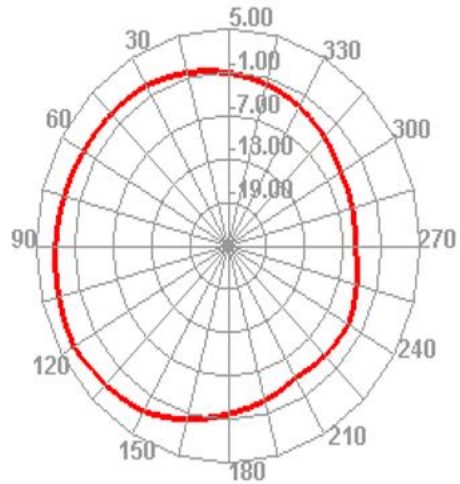

### 2400.000MHz E1

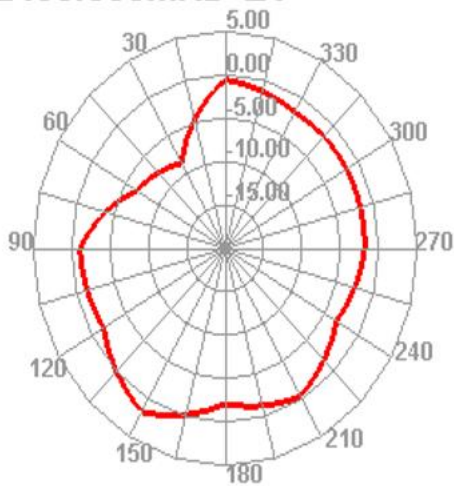

### 2400.000MHz E2

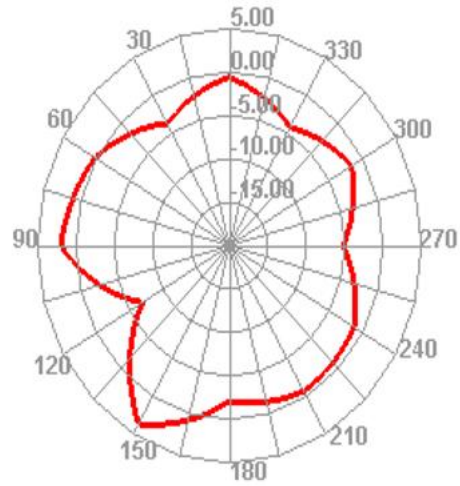

# ANTENNA SPECIFICATION0

CUS P/N : T2970  
CREDITS P/N :

ApplicationDate: 2022-12-9  
Editor:

Rev: R:A0  
Page 6 of 7

2450.000MHz

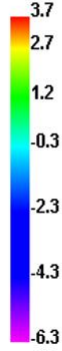
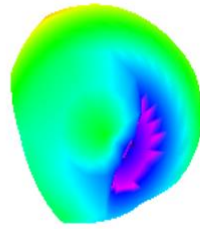

2450.000MHz H

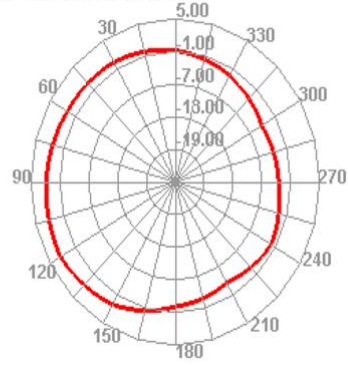

2450.000MHz H

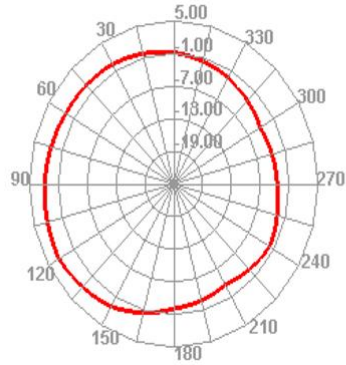

2450.000MHz E2

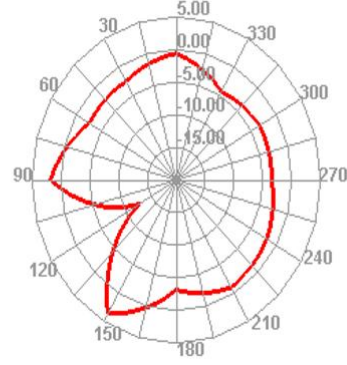

# ANTENNA SPECIFICATION0

CUS P/N : T2970  
 CREDITS P/N :

ApplicationDate: 2022-12-9  
 Editor:

Rev: R:A0  
 Page 7 of 7

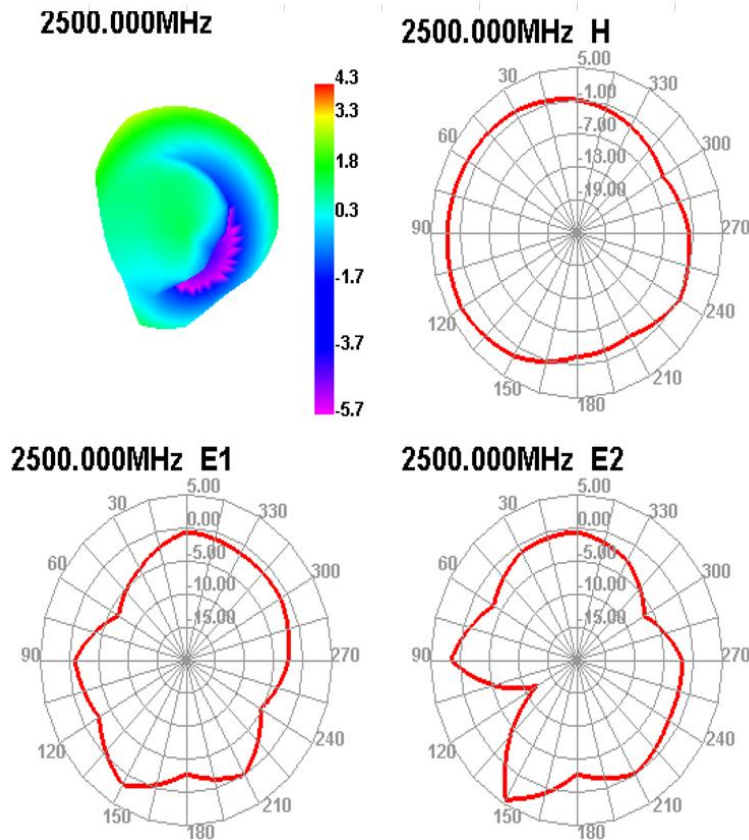

### 3. Mechanical Specification

3-1-1 **Mechanical Configuration( 组装图 )**

3-2 **Measurement Data**

3-3 **Salt-Spray test**

35°C, 85%RH, 48Hours(According to MIL-STD-810E)The

salt-spray is generated from a 5% salt solution., The VSWR, Gain, Radiation Pattern must be met specifications after the salt-spray test.

### 4. Environment Characteristic

NO.	ITEM	TEST CONDITION	SPECIFICATION
4-1	High Temperature/Humidity Storage Test(non operating)	1.Temperature: <b>+70 ±2°C</b> 2.Humidity: <b>90~95%RH</b> 3.Time: <b>48hrs</b>	No material deformation is allowed.

# ANTENNA SPECIFICATION0

CUS P/N : T2970  
 CREDITS P/N :

ApplicationDate: 2022-12-9  
 Editor:

Rev: R:A0  
 Page 8 of 7

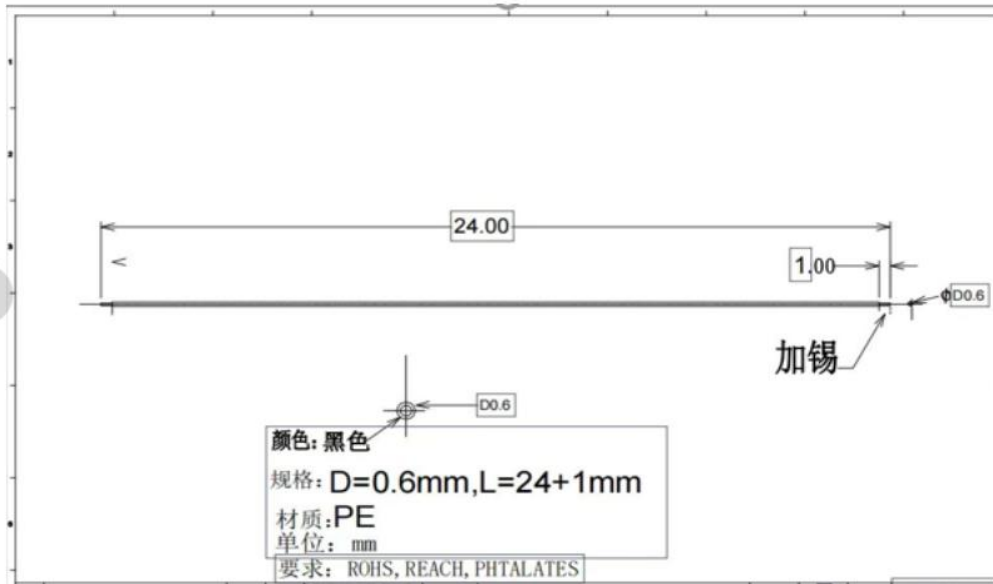

Gain, Radiation  
 to be met  
 after these test.

4-2	Low Temperature/Humidity Storage Test(non operating)	1.Temperature: $-30\pm 2^{\circ}\text{C}$ 2.Humidity: $0\%RH$ 3.Time: $48\text{hrs}$	
-----	---	--	--