

TEST REPORT

Product Name : Monitor
Model Number : 34E9R, XXXX34XXXXXX (“X” can be any alphanumeric character, symbol or blank or none, Represents different color and sales area)
FCC ID : 2A54C-34E9R

Prepared for : Guangxi Century Innovation Display Electronics Co.,Ltd
Address : No.3 standard workshop,Zhongguancun Electronic Industry Park,No. 67 Lianchou Road, Nanning City

Prepared by : EMTEK (SHENZHEN) CO., LTD.
Address : Building 69, Majialong Industry Zone, Nanshan District, Shenzhen, Guangdong, China

Tel: (0755) 26954280
Fax: (0755) 26954282

Report Number : ENS2308180025W00101R
Date(s) of Tests : August 18, 2023 to September 19, 2023
Date of issue : September 19, 2023

\$二维码\$

Table of Contents

1	EUT TECHNICAL DESCRIPTION	4
2	SUMMARY OF TEST RESULT	5
3	TEST METHODOLOGY	6
3.1	GENERAL DESCRIPTION OF APPLIED STANDARDS	6
3.2	MEASUREMENT EQUIPMENT USED	6
3.3	DESCRIPTION OF TEST MODES	7
3.4	INDEPENDENT OPERATION MODES	7
3.5	TEST MANNER	7
4	FACILITIES AND ACCREDITATIONS	8
4.1	FACILITIES	8
4.2	LABORATORY ACCREDITATIONS AND LISTINGS	8
5	TEST SYSTEM UNCERTAINTY	9
6	SETUP OF EQUIPMENT UNDER TEST	10
6.1	RADIO FREQUENCY TEST SETUP 1	10
6.2	RADIO FREQUENCY TEST SETUP 2	10
6.3	CONDUCTED EMISSION TEST SETUP	11
6.4	BLOCK DIAGRAM CONFIGURATION OF TEST SYSTEM	12
6.5	SUPPORT EQUIPMENT	12
7	TEST REQUIREMENTS	13
7.1	OCCUPIED BANDWIDTH	13
7.2	RADIATED SPURIOUS EMISSION	15
7.3	CONDUCTED EMISSION TEST	25
8	ANTENNA APPLICATION	28

TEST RESULT CERTIFICATION

Applicant : Guangxi Century Innovation Display Electronics Co.,Ltd
 Address : No.3 standard workshop,Zhongguancun Electronic Industry Park,No. 67 Lianchou Road, Nanning City
 Manufacturer : Guangxi Century Innovation Display Electronics Co.,Ltd
 Address : No.3 standard workshop,Zhongguancun Electronic Industry Park,No. 67 Lianchou Road, Nanning City
 EUT : Monitor
 Model Name : 34E9R, XXXX34XXXXXX ("X"can be any alphanumeric character, symbol or blank or none, Represents different color and sales area)
 Trademark : Innocn

Measurement Procedure Used:

APPLICABLE STANDARDS	
STANDARD	TEST RESULT
FCC 47 CFR Part 2, Subpart J FCC 47 CFR Part 15, Subpart C	PASS

The above equipment was tested by EMTEK(SHENZHEN) CO., LTD. The test data, data evaluation, test procedures, and equipment configurations shown in this report were made in accordance with the procedures given in ANSI C63.10 (2013) and the energy emitted by the sample EUT tested as described in this report is in compliance with the requirements of FCC Rules Part 15.207&15.209.

The test results of this report relate only to the tested sample identified in this report.

Date of Test : August 18, 2023 to September 19, 2023

Prepared by : Luo Pei Ye
 Luo peiye /Editor

Reviewer : Joe Xia
 Joe Xia/Editor

Approve & Authorized Signer : [Signature]
 Lisa Wang/Manager



1 EUT TECHNICAL DESCRIPTION

Product:	Monitor
Model Number:	34E9R, XXXX34XXXXXX ("X" can be any alphanumeric character, symbol or blank or none, Represents different color and sales area)
Power Supply	Input: 100-240V~50/60Hz, 4.0A Wireless output: 5W/7.5W/10W/15W
Operating Frequency	110-205KHz
Modulation	ASK
Antenna Type	Induction coil antenna
Temperature Range	0°C ~ +50°C

Note: for more details, please refer to the User's manual of the EUT.



2 SUMMARY OF TEST RESULT

FCC Part Clause	Test Parameter	Verdict	Remark
2.1049	Occupied Bandwidth	PASS	
15.209	Radiated Spurious Emissions	PASS	
15.207	Conducted Emission	PASS	
NOTE1: N/A (Not Applicable)			

RELATED SUBMITTAL(S) / GRANT(S):

This submittal(s) (test report) is intended for FCC ID: 2A54C-34E9R filing to comply with Section 15.225 of the FCC Part 15, Subpart C Rules.



3 TEST METHODOLOGY

3.1 GENERAL DESCRIPTION OF APPLIED STANDARDS

According to its specifications, the EUT must comply with the requirements of the following standards:
 FCC 47 CFR Part 2, Subpart J
 FCC 47 CFR Part 15, Subpart C

3.2 MEASUREMENT EQUIPMENT USED

Conducted Emission Test Equipment

Equipment	Manufacturer	Model No.	Serial No.	Last Cal.	DUE CAL.
EMI Test Receiver	Rohde & Schwarz	ESCI	101384	May 14, 2023	1 Year
AMN	Rohde & Schwarz	ENV216	101161	May 14, 2023	1 Year
AMN	Kyoritsu	KNW-407	8-1492-9	May 14, 2023	1 Year

Radiated Emission Test Equipment

Equipment	Manufacturer	Model No.	Serial No.	Last Cal.	DUE CAL.
EMI Test Receiver	Rohde & Schwarz	ESU 26	100154	May 14, 2023	1 Year
Loop Antenna	Schwarzbeck	FMZB1519	1519-012	Jun. 12, 2023	2 Year
Pre-Amplifie	Lunar EM	LNA30M3G-2 5	J10100000070	May 14, 2023	1 Year
Bilog Antenna	Schwarzbeck	VULB9163	661	Jun. 12, 2023	2 Year

Radio Frequency Test Equipment

Equipment	Manufacturer	Model No.	Serial No.	Last Cal.	DUE CAL.
Spectrum Analyzer	Rohde & Schwarz	FSV30	103039	May 14, 2023	1 Year

3.3 DESCRIPTION OF TEST MODES

The EUT has been tested under its charging mode condition.

The EUT configuration for testing is installed on RF field strength measurement to meet the Commissions requirement and operating in a manner which intends to maximize its emission characteristics in a continuous normal application.

The Transmitter was operated in the normal operating mode. The TX frequency was fixed which was for the purpose of the measurements.

Pre-defined engineering program for regulatory testing used to control the EUT for staying in continuous transmitting mode is programmed.

3.4 INDEPENDENT OPERATION MODES

Test Mode A	Description	Remark
Mode A Charging(5W)	100% Load	With dummy load
	50% Load	With dummy load
	10% Load	With dummy load

Test Mode B	Description	Remark
Mode B Charging(7.5W)	100% Load	With dummy load
	50% Load	With dummy load
	10% Load	With dummy load

Test Mode C	Description	Remark
Mode C Charging(10W)	100% Load	With dummy load
	50% Load	With dummy load
	10% Load	With dummy load

Test Mode D	Description	Remark
Mode C Charging(15W)	100% Load	With dummy load
	50% Load	With dummy load
	10% Load	With dummy load

3.5 TEST MANNER

Test Items	Test Voltage	Operation Modes	Worst case
Conducted Emission	AC 120/60Hz	Mode A, B, C,D	Mode D(100% Load)
Radiated Emission	AC 120/60Hz	Mode A, B, C,D	Mode D(100% Load)
99% Occupied Bandwidth	AC 120/60Hz	Mode A, B, C,D	Mode D(100% Load)

Notes: The EUT supports charging the load while charging itself.

All wireless charging modes have been tested, and the worst mode is shown below.

4 FACILITIES AND ACCREDITATIONS

4.1 FACILITIES

All measurement facilities used to collect the measurement data are located at

Building 69, Majialong Industry Zone District, Nanshan District, Shenzhen, China

The sites are constructed in conformance with the requirements of ANSI C63.7, ANSI C63.10 and CISPR Publication 22.

4.2 LABORATORY ACCREDITATIONS AND LISTINGS

Site Description

EMC Lab.

: **Accredited by CNAS**

The Certificate Registration Number is L2291.

The Laboratory has been assessed and proved to be in compliance with CNAS-CL01 (identical to ISO/IEC 17025:2017)

Accredited by FCC

Designation Number: CN1204

Test Firm Registration Number: 882943

Accredited by A2LA

The Certificate Number is 4321.01.

Accredited by Industry Canada

The Conformity Assessment Body Identifier is CN0008

Name of Firm

: EMTEK (SHENZHEN) CO., LTD.

Site Location

: Building 69, Majialong Industry Zone,
Nanshan District, Shenzhen, Guangdong, China

5 TEST SYSTEM UNCERTAINTY

The following measurement uncertainty levels have been estimated for tests performed on the apparatus:

Parameter	Uncertainty
Radio Frequency	$\pm 1 \times 10^{-5}$
Conducted Emissions Test	$\pm 2.0\text{dB}$
Radiated Emission Test	$\pm 2.0\text{dB}$
Occupied Bandwidth Test	$\pm 1.0\text{dB}$
All emission, radiated	$\pm 3\text{dB}$
Temperature	$\pm 0.5^\circ\text{C}$
Humidity	$\pm 3\%$

Measurement Uncertainty for a level of Confidence of 95%



6 SETUP OF EQUIPMENT UNDER TEST

6.1 RADIO FREQUENCY TEST SETUP 1

The component's antenna ports(s) of the EUT are connected to the measurement instrument per an appropriate attenuator. The EUT is controlled by PC/software to emit the specified signals for the purpose of measurements.

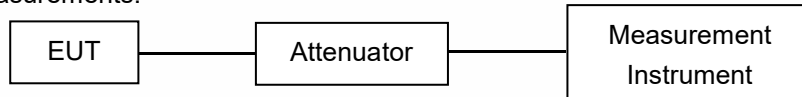

6.2 RADIO FREQUENCY TEST SETUP 2

The test site semi-anechoic chamber has met the requirement of NSA tolerance 4 dB according to the standards: ANSI C63.10. The test distance is 3m. The setup is according to the requirements in Section 13.1.4.1 of ANSI C63.10-2013 and CAN/CSA-CEI/IEC CISPR 22.

Below 30MHz:

The EUT is placed on a turntable 0.8 meters above the ground in the chamber, 3 meter away from the antenna (loop antenna). The Antenna should be positioned with its plane vertical at the specified distance from the EUT and rotated about its vertical axis for maximum response at each azimuth about the EUT. The center of the loop shall be 1 m above the ground. For certain applications, the loop antenna plane may also need to be positioned horizontally at the specified distance from the EUT.

Above 30MHz:

The EUT is placed on a turntable 0.8 meters above the ground in the chamber, 3 meter away from the antenna. The maximal emission value is acquired by adjusting the antenna height, polarisation and turntable azimuth. Normally, the height range of antenna is 1 m to 4 m, the azimuth range of turntable is 0° to 360°, and the receive antenna has two polarizations Vertical (V) and Horizontal (H).

(a) Radiated Emission Test Set-Up, Frequency Below 30MHz

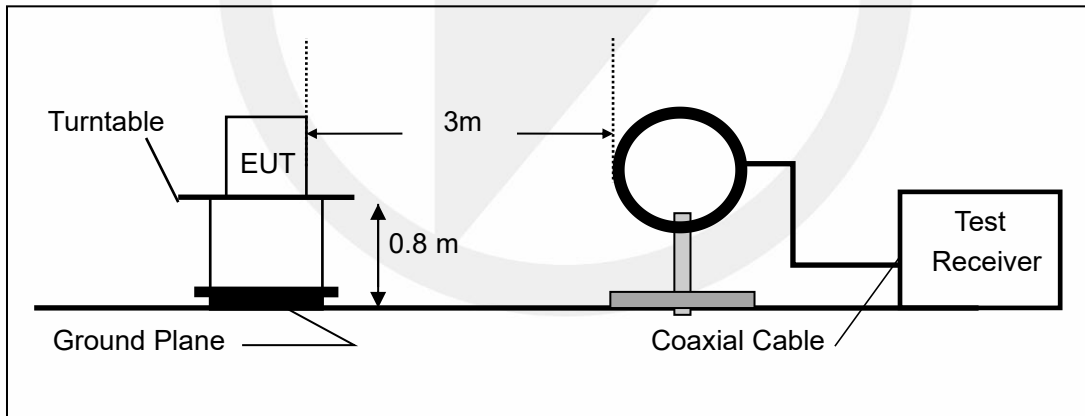

(b) Radiated Emission Test Set-Up, Frequency Below 1000MHz

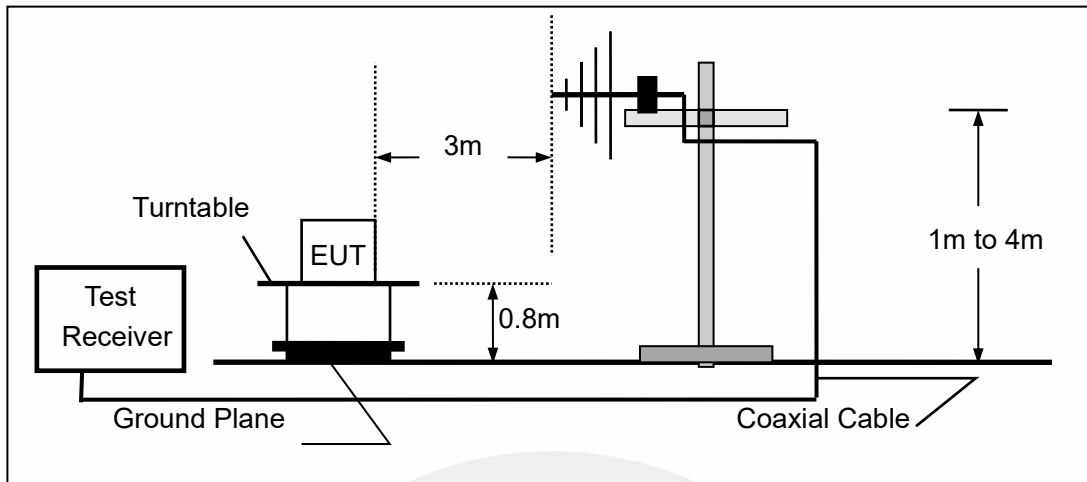

6.3 CONDUCTED EMISSION TEST SETUP

The mains cable of the EUT (maybe per AC/DC Adapter) must be connected to LISN. The LISN shall be placed 0.8 m from the boundary of EUT and bonded to a ground reference plane for LISN mounted on top of the ground reference plane. This distance is between the closest points of the LISN and the EUT. All other units of the EUT and associated equipment shall be at least 0.8m from the LISN.

Ground connections, where required for safety purposes, shall be connected to the reference ground point of the LISN and, where not otherwise provided or specified by the manufacturer, shall be of same length as the mains cable and run parallel to the mains connection at a separation distance of not more than 0.1 m.

According to the requirements in ANSI C63.10-2013 Conducted emissions from the EUT measured in the frequency range between 0.15 MHz and 30 MHz using CISPR Quasi-Peak and average detector mode.

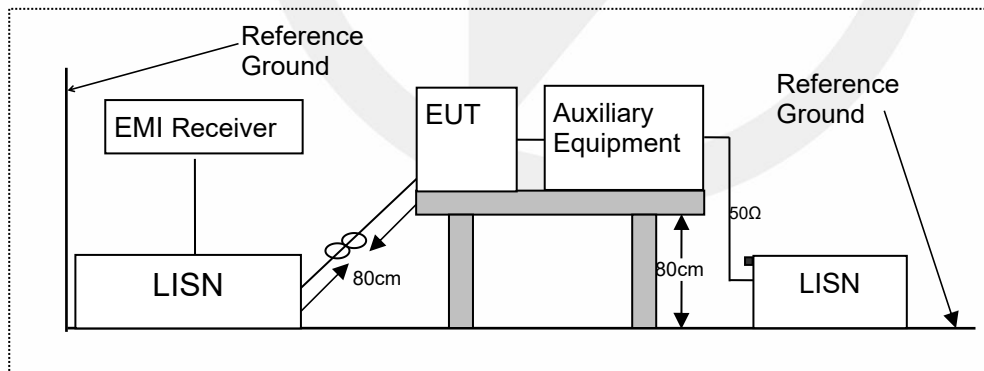

6.4 BLOCK DIAGRAM CONFIGURATION OF TEST SYSTEM

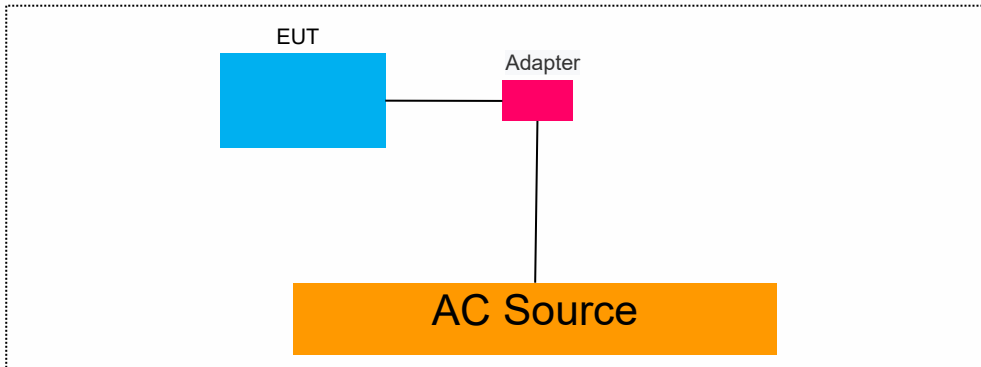

6.5 SUPPORT EQUIPMENT

EUT Cable List and Details			
Cable Description	Length (m)	Shielded/Unshielded	With / Without Ferrite
/	/	/	/

Auxiliary Cable List and Details			
Cable Description	Length (m)	Shielded/Unshielded	With / Without Ferrite

Auxiliary Equipment List and Details			
Description	Manufacturer	Model	Serial Number
Dummy Load	HFJ-AR	ME47562021	/

Notes:

1. All the equipment/cables were placed in the worst-case configuration to maximize the emission during the test.
2. Grounding was established in accordance with the manufacturer's requirements and conditions for the intended use.
3. Unless otherwise denoted as EUT in 『Remark』 column, device(s) used in tested system is a support equipment

7 TEST REQUIREMENTS

7.1 OCCUPIED BANDWIDTH

7.1.1 Applicable Standard

According to FCC Part 2.1049

7.1.2 Conformance Limit

No limit requirement.

7.1.3 Test Configuration

Test according to clause 6.1 radio frequency test setup 1

7.1.4 Test Procedure

The EUT was operating in transmit mode and controlled its channel. Printed out the test result from the spectrum by hard copy function.

The RF output of EUT was connected to the spectrum analyzer by RF cable and attenuator. The path loss was compensated to the results for each measurement.

Set to the maximum power setting and enable the EUT transmit continuously

Set RBW = 1% occupied bandwidth (30Hz).

Set the video bandwidth (VBW) =3 times RBW .

Set Span= approximately 2 to 3 times the occupied bandwidth

Set Detector = Peak.

Set Trace mode = max hold.

Set Sweep = auto couple.

The EUT should be transmitting at its maximum data rate. Allow the trace to stabilize. Use the marker-to-peak function to set the marker to the peak of the emission. Use the marker-delta function to measure 99% down one side of the emission. Reset the markerdelta function, and move the marker to the other side of the emission, until it is (as close as possible to) even with the reference marker level. The marker-delta reading at this point is the 99% bandwidth of the emission.

If this value varies with different modes of operation (e.g., data rate, modulation format, etc.), repeat this test for each variation.

Measure and record the results in the test report.

7.1.5 Test Results

Temperature :	25°C	Test Date :	August 22, 2022
Humidity :	65 %	Test By:	XXH

Modulation Mode	Channel Number	Channel Frequency (KHz)	-20dB Measurement Bandwidth (kHz)	Limit (kHz)	Verdict
ASK	/	127.7KHz	0.305	N/A	PASS
Note: N/A (Not Applicable)					

Test Model

-20dB Bandwidth
Frequency: 127.7KHz

ASK Modulation

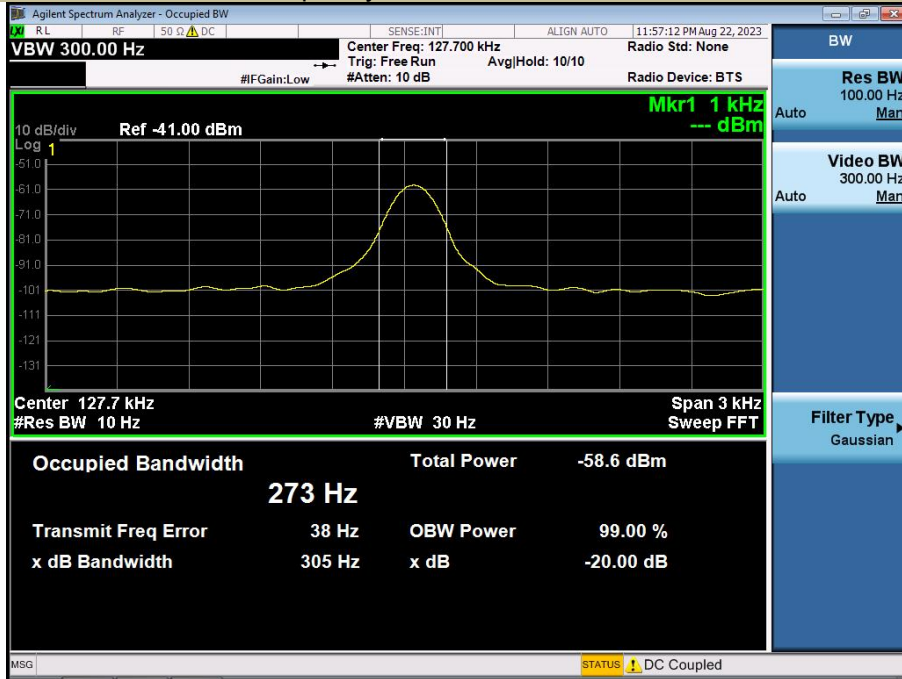

7.2 RADIATED SPURIOUS EMISSION

7.2.1 Applicable Standard

According to FCC Part 15.209

7.2.2 Conformance Limit

FCC Part 15.209				
Frequency (MHz)	Field Strength Limitation		Field Strength Limitation Frequency tion at 3m Measurement Dist	
	(uV/m)	Dist	(uV/m)	(dBuV/m)
0.009 – 0.490	2400 / F(KHz)	300m	10000 * 2400/F(KHz)	20log 2400/F(KHz) + 80
0.490 – 1.705	24000 / F(KHz)	30m	100 * 24000/F(KHz)	20log 24000/F(KHz) + 40
1.705 – 30.00	30	30m	100* 30	20log 30 + 40
30.0 – 88.0	100	3m	100	20log 100
88.0 – 216.0	150	3m	150	20log 150
216.0 – 960.0	200	3m	200	20log 200
Above 960.0	500	3m	500	20log 500

According to FCC Part15.205, Restricted bands

MHz	MHz	MHz	GHz
0.090-0.110	16.42-16.423	399.9-410	4.5-5.15
10.495-0.505	16.69475-16.69525	608-614	5.35-5.46
2.1735-2.1905	16.80425-16.80475	960-1240	7.25-7.75
4.125-4.128	25.5-25.67	1300-1427	8.025-8.5
4.17725-4.17775	37.5-38.25	1435-1626.5	9.0-9.2
4.20725-4.20775	73-74.6	1645.5-1646.5	9.3-9.5
6.215-6.218	74.8-75.2	1660-1710	10.6-12.7
6.26775-6.26825	123-138	2200-2300	14.47-14.5
8.291-8.294	149.9-150.05	2310-2390	15.35-16.2
8.362-8.366	156.52475-156.52525	2483.5-2500	17.7-21.4
8.37625-8.38675	156.7-156.9	2690-2900	22.01-23.12
8.41425-8.41475	162.0125-167.17	3260-3267	23.6-24.0
12.29-12.293	167.72-173.2	3332-3339	31.2-31.8
12.51975-12.52025	240-285	3345.8-3358	36.43-36.5
12.57675-12.57725	322-335.4	3600-4400	(2)
13.36-13.41			

Remark: 1. Emission level in dBuV/m=20 log (uV/m)
 2. Measurement was performed at an antenna to the closed point of EUT distance of meters.
 3. Only spurious frequency is permitted to locate within the Restricted Bands specified in provision of § 15.205, and the emissions located in restricted bands also comply with 15.209 limit.

7.2.3 Test Configuration

Test according to clause 6.2 radio frequency test setup 2

7.2.4 Test Procedure

This test is required for any spurious emission that falls in a Restricted Band, as defined in Section 15.205. It must be performed with the highest gain of each type of antenna proposed for use with the

EUT. Use the following spectrum analyzer settings:

The EUT was placed on a turn table which is 0.8m above ground plane.

Maximum procedure was performed on the highest emissions to ensure EUT compliance.

Span = wide enough to fully capture the emission being measured

RBW = 100 kHz for $f < 1$ GHz(30MHz to 1GHz), 200Hz for $f < 150$ KHz(9KHz to 150KHz), 9KHz for $f < 30$ MHz(150KHz to 30KHz)

VBW \geq RBW

Sweep = auto

Detector function = peak

Trace = max hold

Follow the guidelines in ANSI C63.10-2013 with respect to maximizing the emission by rotating the EUT, measuring the emission while the EUT is situated in three orthogonal planes (if appropriate), adjusting the measurement antenna height and polarization, etc. A pre-amp and a high pass filter are required for this test, in order to provide the measuring system with sufficient sensitivity. Allow the trace to stabilize. The peak reading of the emission, after being corrected by the antenna factor, cable loss, pre-amp gain, etc., is the peak field strength, which must comply with the limit specified in Section 15.35(b). Submit this data.

Now set the VBW to 10 Hz, while maintaining all of the other instrument settings. This peak level, once corrected, must comply with the limit specified in Section 15.209. If the dwell time per channel of the hopping signal is less than 100 ms, then the reading obtained with the 10 Hz VBW may be further adjusted by a "duty cycle correction factor", derived from $20\log(\text{dwell time}/100 \text{ ms})$, in an effort to demonstrate compliance with the 15.209 limit. Submit this data.

Repeat above procedures until all frequency measured was complete.

7.2.5 Test Results

Temperature:	28.1° C
Relative Humidity:	43%
ATM Pressure:	1011 mbar

■ Field Strength of the fundamental signal

Freq. (KHz)	Ant.Pol.	Reading Level (dBuV/m)	Correct Factor (dB/m)	Corrected Reading (dBuV/m)	Limit 3m (dBuV/m)	Margin (dB)
127.60	X	30.30	20.14	50.44	105.48	-55.04
127.60	Y	28.70	20.14	48.84	105.48	-56.64
127.60	Z	29.20	20.14	49.34	105.45	-56.14

Note: (1) Corrected Reading = Reading Level + Correct Factor;

(2) Correct Factor = Ant_F + Cab_L - Preamp;

(3) Margin = Limit - Corrected Reading;

■ Spurious Emission below 150kHz (9kHz to 150kHz)

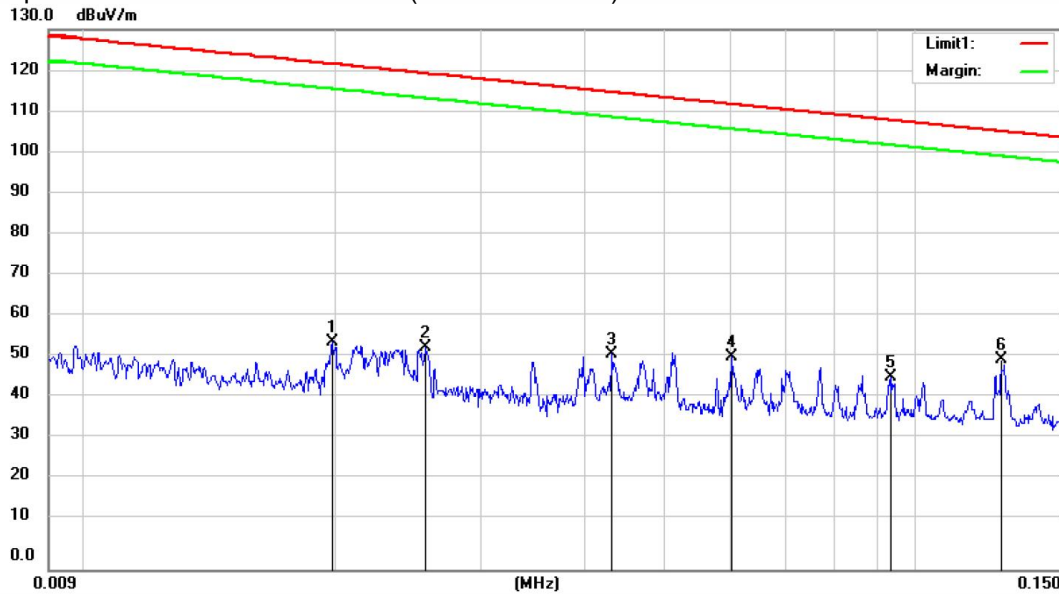

Site 3m Chamber #3

Polarization: X

Temperature: 26 C

Limit: (RE)FCC PART 15.209(9K-30M)
Mode: wireless charging (15W)100%Load

Power: AC 120V/60Hz

Humidity: 60 %

Note:

No.	Mk.	Freq. MHz	Reading Level dBuV	Correct Factor dB	Measure- ment dBuV/m	Limit dBuV/m	Over dB	Detector	Antenna Height cm	Table Degree degree	Comment
1		0.0196	34.46	20.40	54.86	121.74	-66.88	peak			
2		0.0256	33.03	20.40	53.43	119.43	-66.00	peak			
3		0.0430	31.18	20.59	51.77	114.92	-63.15	peak			
4		0.0601	30.46	20.60	51.06	112.02	-60.96	peak			
5		0.0937	25.85	20.56	46.41	108.16	-61.75	peak			
6	*	0.1276	30.30	20.14	50.44	105.48	-55.04	peak			

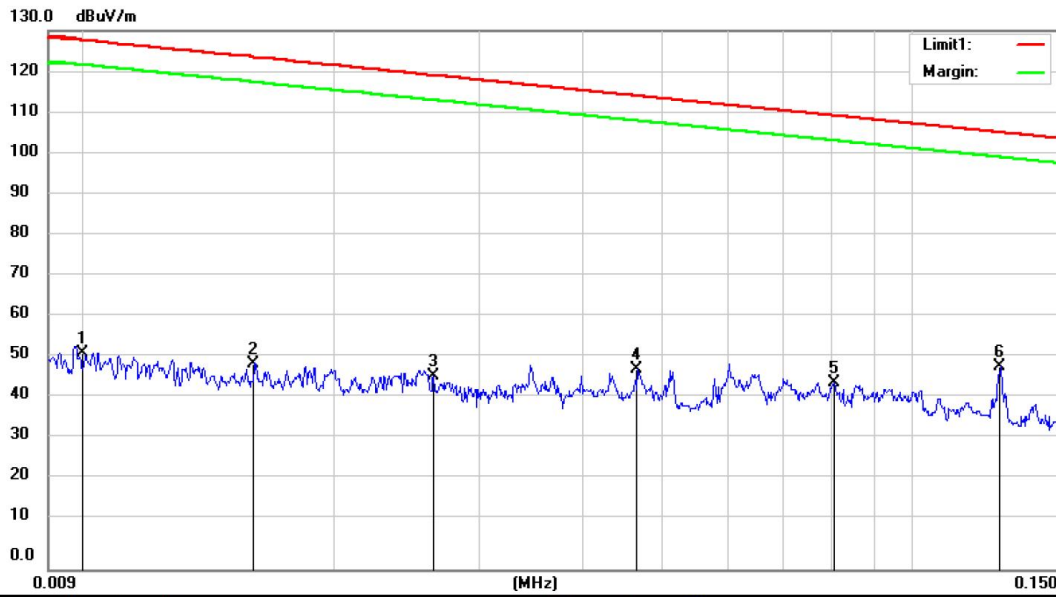

Site 3m Chamber #3 Polarization: **Y** Temperature: 26 C
 Limit: (RE)FCC PART 15.209(9K-30M) Power: AC 120V/60Hz Humidity: 60 %
 Mode:wireless charging (15W)100%Load
 Note:

No.	Mk.	Freq.	Reading Level	Correct Factor	Measurement	Limit	Over	Antenna Height	Table Degree	
		MHz	dBuV	dB	dBuV/m	dBuV/m	dB	cm	degree	Comment
1		0.0100	31.84	20.40	52.24	127.59	-75.35			peak
2		0.0160	29.06	20.40	49.46	123.51	-74.05			peak
3		0.0263	26.34	20.40	46.74	119.19	-72.45			peak
4		0.0463	27.77	20.64	48.41	114.28	-65.87			peak
5		0.0805	24.32	20.55	44.87	109.48	-64.61			peak
6	*	0.1276	28.70	20.14	48.84	105.48	-56.64			peak

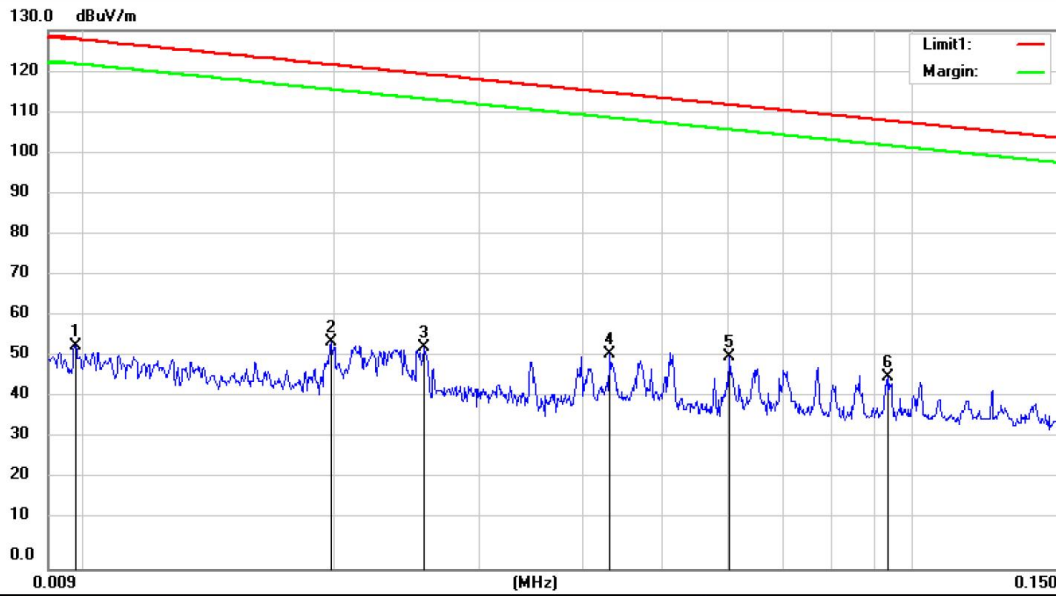

Site 3m Chamber #2 Polarization: **Z** Temperature: 26 C
 Limit: (RE)FCC PART 15.209(9K-30M) Power: AC 120V/60Hz Humidity: 60 %
 Mode: wireless charging (15W)100%Load
 Note:

No.	Mk.	Freq. MHz	Reading Level dBuV	Correct Factor dB	Measure- ment dBuV/m	Limit dBuV/m	Over dB	Antenna Height cm	Table Degree	Comment
1		0.0126	31.06	20.40	51.46	125.58	-74.12	peak		
2		0.0194	31.90	20.40	52.30	121.83	-69.53	peak		
3		0.0316	27.03	20.42	47.45	117.60	-70.15	peak		
4		0.0541	23.70	20.66	44.36	112.93	-68.57	peak		
5		0.0864	22.91	20.58	43.49	108.87	-65.38	peak		
6	*	0.1276	29.20	20.14	49.34	105.48	-56.14	peak		

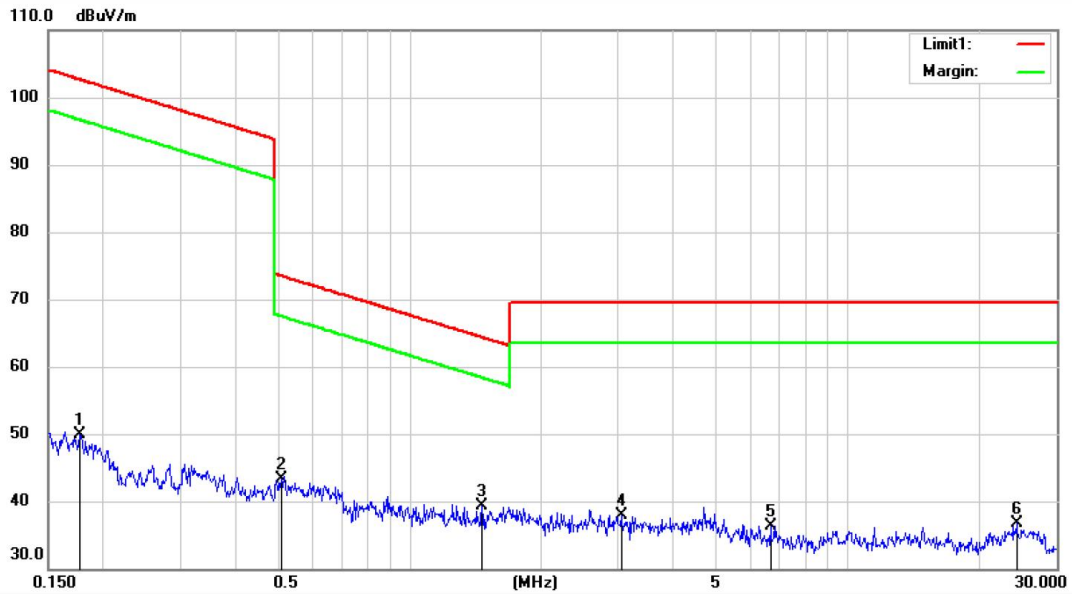

Site 3m Chamber #2
 Limit: (RE)FCC PART 15.209(9K-30M)
 Mode: wireless charging(15W) 100% Load
 Note:

Polarization: X
 Power: AC 120V/60Hz
 Temperature: 26 C
 Humidity: 60 %

No.	Mk.	Freq. MHz	Reading Level dBuV	Correct Factor dB	Measure- ment dBuV/m	Limit dBuV/m	Over dB	Detector	Antenna Height cm	Table Degree	Comment
1		0.1766	29.67	20.15	49.82	102.66	-52.84	peak			
2		0.5100	22.56	20.80	43.36	73.45	-30.09	peak			
3	*	1.4640	18.64	20.71	39.35	64.32	-24.97	peak			
4		3.0412	17.52	20.40	37.92	69.50	-31.58	peak			
5		6.6623	15.87	20.38	36.25	69.50	-33.25	peak			
6		24.2704	17.08	19.63	36.71	69.50	-32.79	peak			

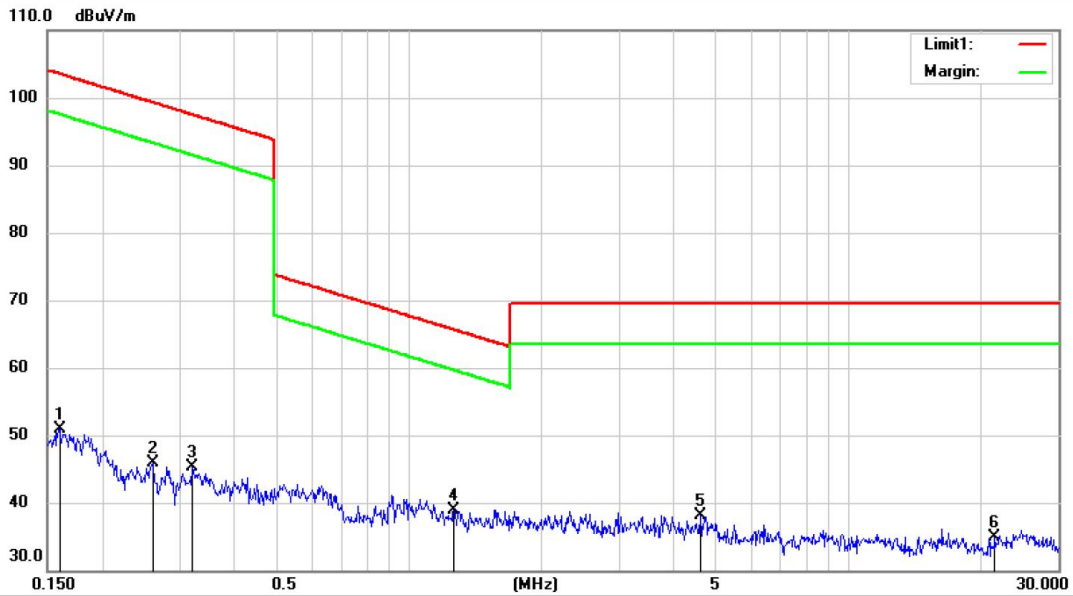

Site 3m Chamber #2 Polarization: Y Temperature: 26 C
 Limit: (RE)FCC PART 15.209(9K-30M) Power: AC 120V/60Hz Humidity: 60 %
 Mode:wireless charging(15W) 100% Load
 Note:

No.	Mk.	Freq. MHz	Reading Level dBuV	Correct Factor dB	Measure- ment dBuV/m	Limit dBuV/m	Over dB	Antenna Height cm	Table Degree degree	Detector	Comment
1		0.1597	30.86	20.12	50.98	103.53	-52.55			peak	
2		0.2601	25.61	20.32	45.93	99.30	-53.37			peak	
3		0.3200	24.84	20.44	45.28	97.50	-52.22			peak	
4	*	1.2620	18.08	20.75	38.83	65.61	-26.78			peak	
5		4.5978	17.75	20.32	38.07	69.50	-31.43			peak	
6		21.4860	15.25	19.58	34.83	69.50	-34.67			peak	

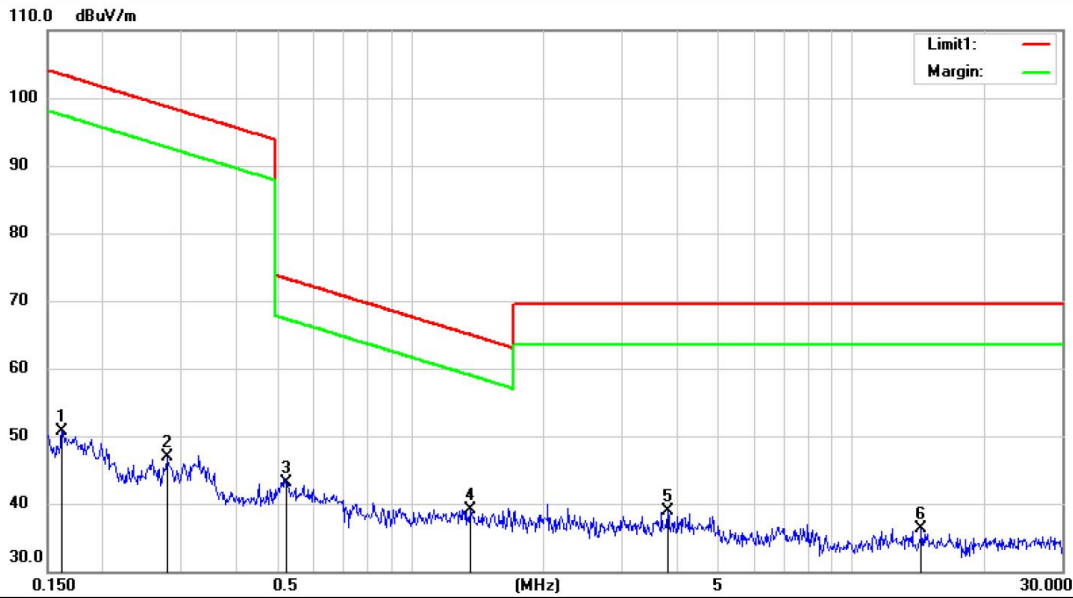

Site 3m Chamber #2 Polarization: Z Temperature: 26 C
 Limit: (RE)FCC PART 15.209(9K-30M) Power: AC 120V/60Hz Humidity: 60 %
 Mode:wireless charging(15W) 100% Load
 Note:

No.	Mk.	Freq. MHz	Reading Level dBuV	Correct Factor dB	Measure- ment dBuV/m	Limit dBuV/m	Over dB	Antenna Height cm	Table Degree	Detector	Comment
1		0.1615	30.51	20.12	50.63	103.44	-52.81			peak	
2		0.2802	26.45	20.36	46.81	98.65	-51.84			peak	
3		0.5210	22.34	20.80	43.14	73.27	-30.13			peak	
4	*	1.3665	18.46	20.73	39.19	64.92	-25.73			peak	
5		3.8195	18.50	20.36	38.86	69.50	-30.64			peak	
6		14.3640	16.44	19.76	36.20	69.50	-33.30			peak	

■ Spurious Emission Above 30MHz (30MHz to 1GHz)

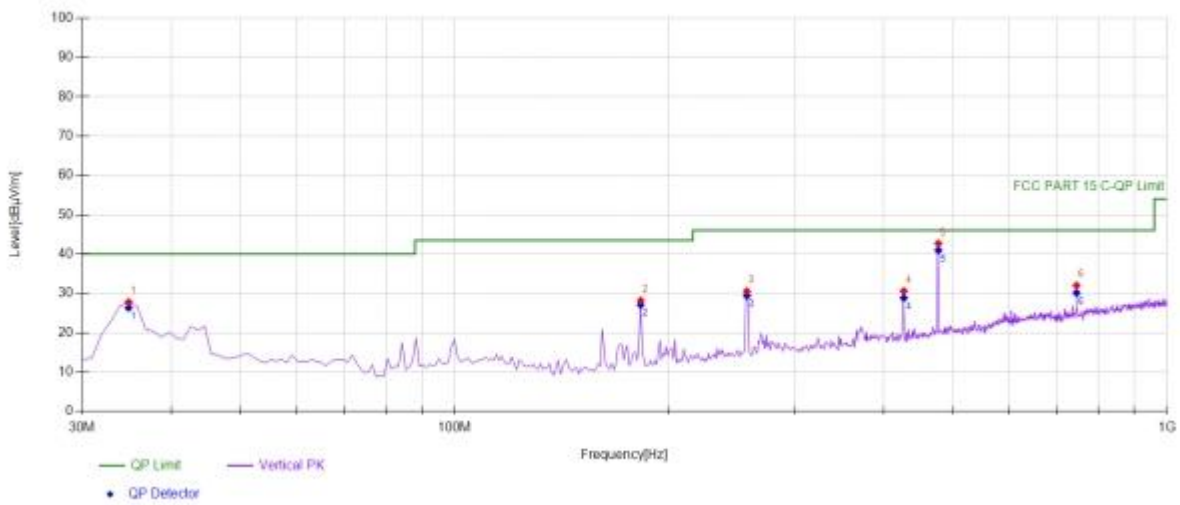

Suspected Data List								
NO.	Freq. [MHz]	Reading [dBµV]	Factor [dB/m]	Level [dBµV/m]	Detector	Limit [dBµV/m]	Margin [dB]	Polarity
1	34.8549	46.02	-18.23	27.79	PK	40.00	12.21	Vertical
2	182.4424	46.42	-18.24	28.18	PK	43.50	15.32	Vertical
3	257.2072	45.71	-15.17	30.54	PK	46.00	15.46	Vertical
4	427.1271	42.11	-11.53	30.58	PK	46.00	15.42	Vertical
5	477.6176	52.63	-9.93	42.70	PK	46.00	3.30	Vertical
6	746.5766	37.36	-5.34	32.02	PK	46.00	13.98	Vertical

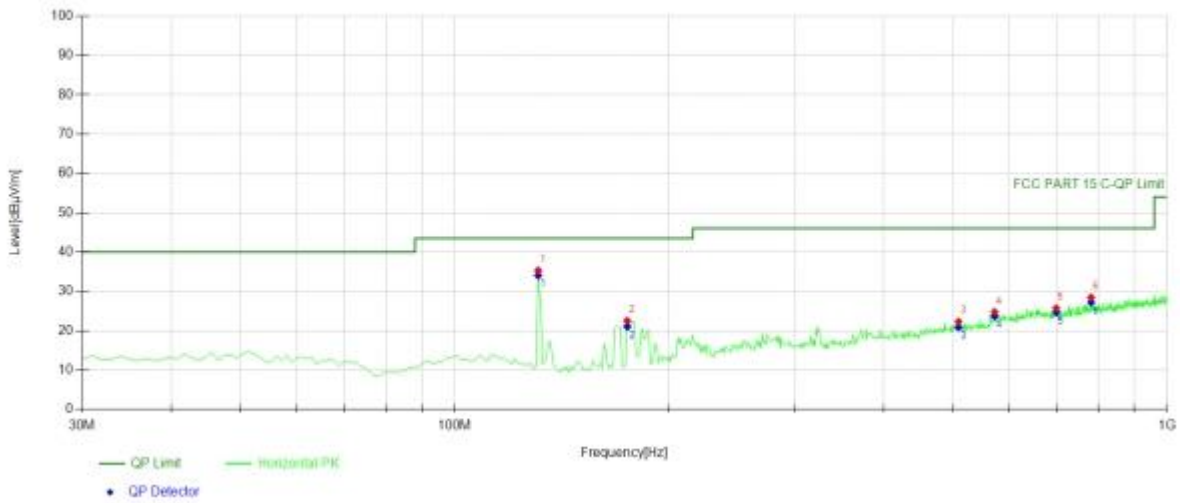

Suspected Data List								
NO.	Freq. [MHz]	Reading [dBµV]	Factor [dB/m]	Level [dBµV/m]	Detector	Limit [dBµV/m]	Margin [dB]	Polarity
1	130.981	54.42	-19.10	35.32	PK	43.50	8.18	Horizontal
2	174.674 7	41.20	-18.69	22.51	PK	43.50	20.99	Horizontal
3	509.659 7	32.09	-9.78	22.31	PK	46.00	23.69	Horizontal
4	572.772 8	32.58	-7.80	24.78	PK	46.00	21.22	Horizontal
5	698.999	31.67	-5.95	25.72	PK	46.00	20.28	Horizontal
6	782.502 5	33.04	-4.59	28.45	PK	46.00	17.55	Horizontal

7.3 CONDUCTED EMISSION TEST

7.3.1 Applicable Standard

According to FCC Part 15.207(a)

7.3.2 Conformance Limit

Conducted Emission Limit		
Frequency(MHz)	Quasi-peak	Average
0.15-0.5	66-56	56-46
0.5-5.0	56	46
5.0-30.0	60	50

Note: 1. The lower limit shall apply at the transition frequencies
2. The limit decreases in line with the logarithm of the frequency in the range of 0.15 to 0.50MHz.

7.3.3 Test Configuration

Test according to clause 7.3 conducted emission test setup

7.3.4 Test Procedure

The EUT was placed on a table which is 0.8m above ground plane.
Maximum procedure was performed on the highest emissions to ensure EUT compliance.
Repeat above procedures until all frequency measured were complete.

7.3.5 Test Results

Pass.

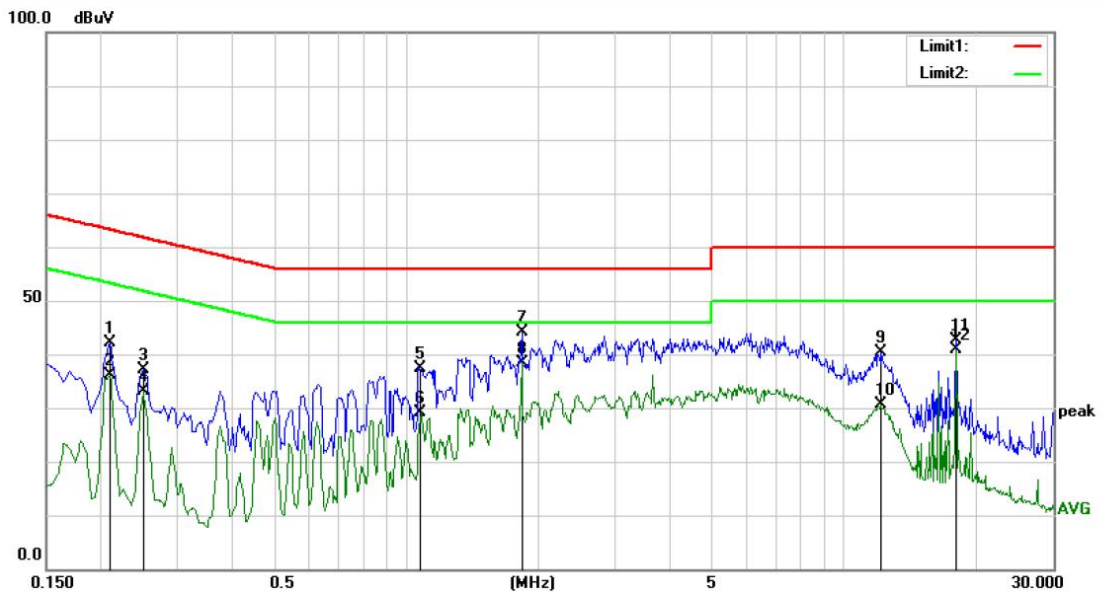

Site Conduction #1 Phase: **L1** Temperature: 21.9
 Limit: (CE)FCC PART 15 class B_QP Power: AC 120V/60Hz Humidity: 58 %
 Mode: wireless charging(15W)100% Load
 Note:

No.	Mk.	Freq. MHz	Reading Level dBuV	Correct Factor dB	Measure- ment dBuV	Limit dBuV	Over dB	Detector	Comment
1		0.2100	32.04	10.09	42.13	63.21	-21.08	QP	
2		0.2100	25.95	10.09	36.04	53.21	-17.17	AVG	
3		0.2500	27.09	10.06	37.15	61.76	-24.61	QP	
4		0.2500	23.18	10.06	33.24	51.76	-18.52	AVG	
5		1.0750	27.66	9.84	37.50	56.00	-18.50	QP	
6		1.0750	19.21	9.84	29.05	46.00	-16.95	AVG	
7		1.8300	34.51	9.73	44.24	56.00	-11.76	QP	
8	*	1.8300	28.58	9.73	38.31	46.00	-7.69	AVG	
9		12.1300	30.47	9.99	40.46	60.00	-19.54	QP	
10		12.1300	20.71	9.99	30.70	50.00	-19.30	AVG	
11		17.9550	32.33	10.18	42.51	60.00	-17.49	QP	
12		17.9550	30.58	10.18	40.76	50.00	-9.24	AVG	

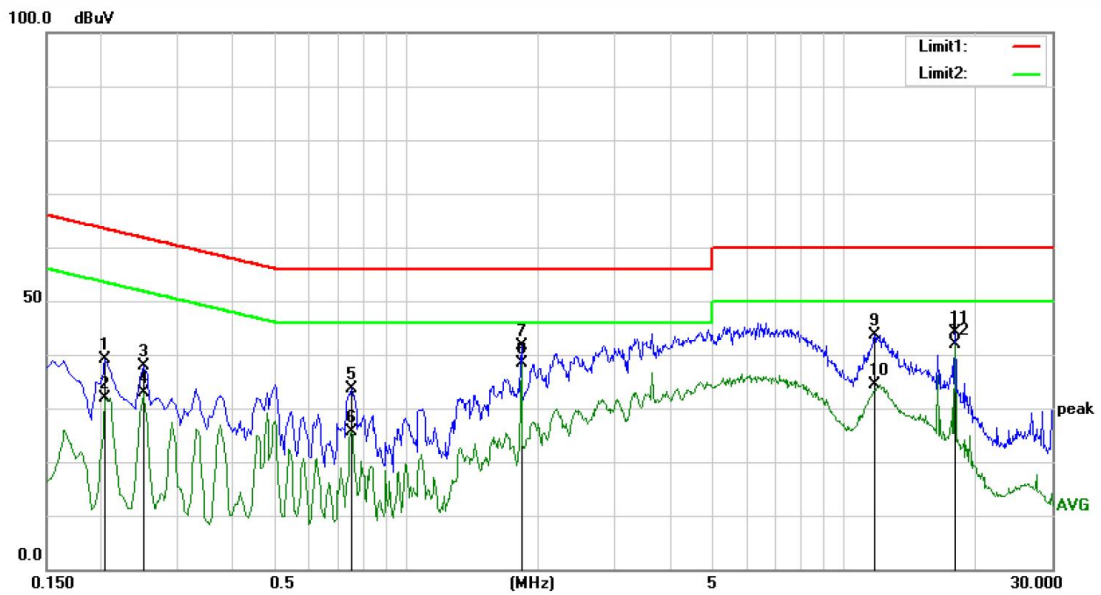

Site Conduction #1 Phase: **N** Temperature: 21.9
 Limit: (CE)FCC PART 15 class B_QP Power: AC 120V/60Hz Humidity: 58 %
 Mode:wireless charging(15W)100% Load
 Note:

No.	Mk.	Freq. MHz	Reading Level dBuV	Correct Factor dB	Measure- ment dBuV	Limit dBuV	Over dB	Detector	Comment
1		0.2050	28.94	10.10	39.04	63.41	-24.37	QP	
2		0.2050	21.68	10.10	31.78	53.41	-21.63	AVG	
3		0.2500	27.75	10.06	37.81	61.76	-23.95	QP	
4		0.2500	22.75	10.06	32.81	51.76	-18.95	AVG	
5		0.7500	23.96	9.68	33.64	56.00	-22.36	QP	
6		0.7500	15.90	9.68	25.58	46.00	-20.42	AVG	
7		1.8300	31.85	9.73	41.58	56.00	-14.42	QP	
8	*	1.8300	28.53	9.73	38.26	46.00	-7.74	AVG	
9		11.8050	33.76	9.99	43.75	60.00	-16.25	QP	
10		11.8050	24.48	9.99	34.47	50.00	-15.53	AVG	
11		17.9550	33.93	10.18	44.11	60.00	-15.89	QP	
12		17.9550	31.76	10.18	41.94	50.00	-8.06	AVG	

8 ANTENNA APPLICATION

8.1.1 Antenna Requirement

Standard	Requirement
FCC CRF Part 15.203	An intentional radiator shall be designed to ensure that no antenna other than that furnished by the responsible party shall be used with the device. The use of a permanently attached antenna or of an antenna that uses a unique coupling to the intentional radiator shall be considered sufficient to comply with the provisions of this section. The manufacturer may design the unit so that a broken antenna can be replaced by the user, but the use of a standard antenna jack or electrical connector is prohibited. This requirement does not apply to carrier current devices or to devices operated under the provisions of §15.211, §15.213, §15.217, §15.219, or §15.221. Further, this requirement does not apply to intentional radiators that must be professionally installed, such as perimeter protection systems and some field disturbance sensors, or to other intentional radiators which, in accordance with §15.31(d), must be measured at the installation site. However, the installer shall be responsible for ensuring that the proper antenna is employed so that the limits in this part are not exceeded.

For intentional device, according to FCC 47 CFR Section 15.203, an intentional radiator shall be designed to ensure that no antenna other than that furnished by the responsible party shall be used with the device. if transmitting antennas of directional gain greater than 6dBi are used, the power shall be reduced by the amount in dB that the directional gain of the antenna exceeds 6dBi.

8.1.2 Result

PASS.

- Note:
- Antenna use a permanently attached antenna which is not replaceable.
 - Not using a standard antenna jack or electrical connector for antenna replacement
 - The antenna has to be professionally installed (please provide method of installation)

Please refer to the attached document Internal Photos to show the antenna connector.

*** End of Report ***