

# SPECIFICATION FOR APPROVAL

## 1. MECHANICAL DIMENSION (UNIT:mm)

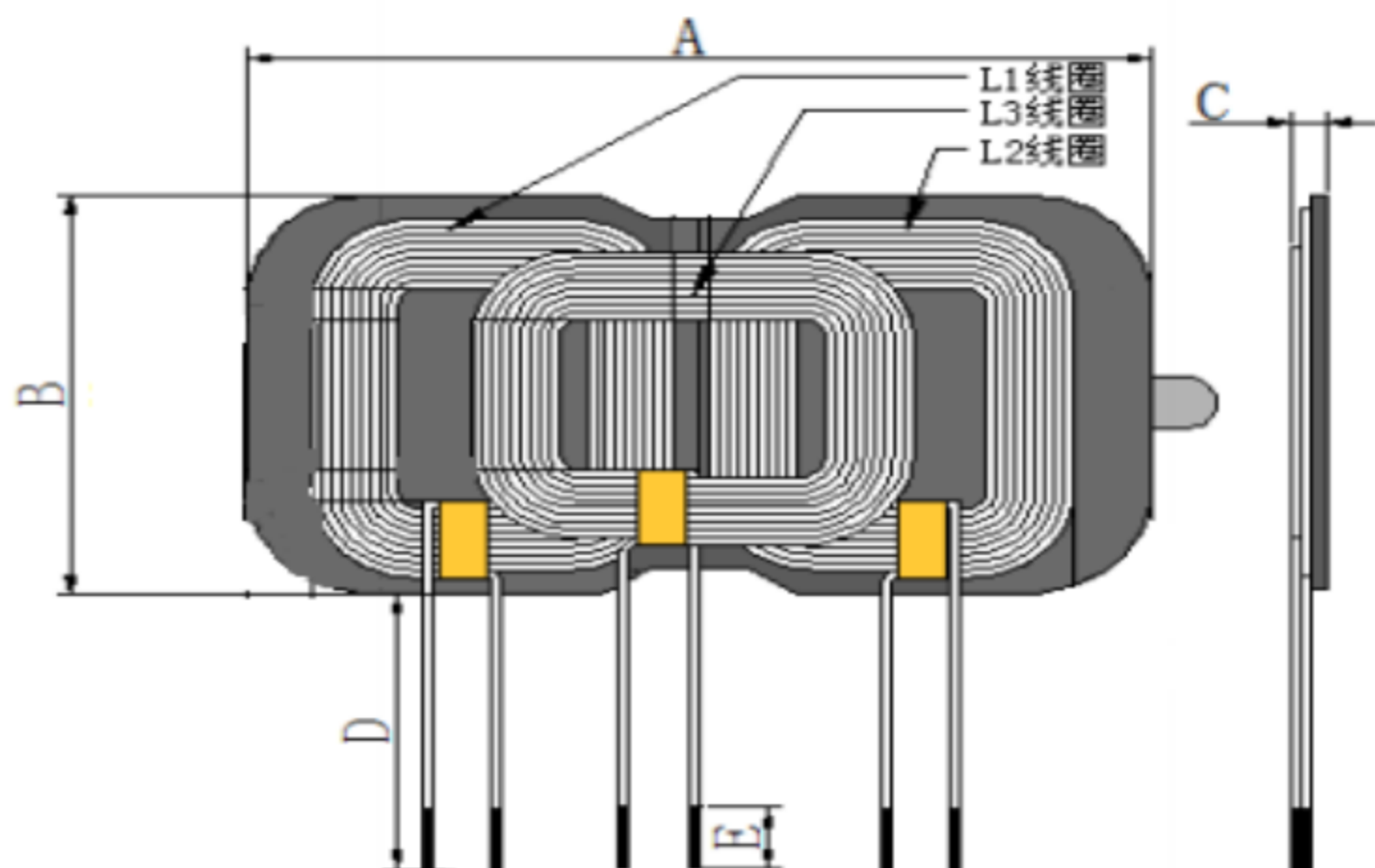

## 2. SCHEMATICS:

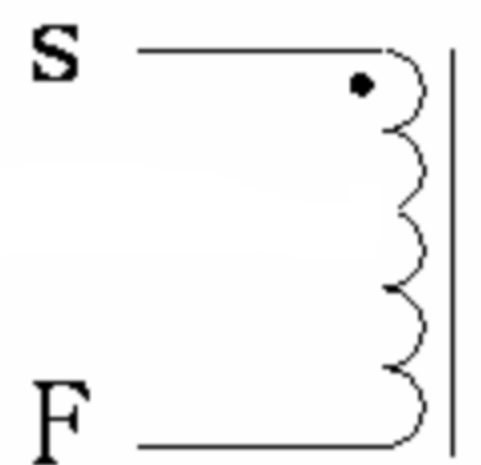

Operation frequency:113kHz-205kHz

A	B	C	D	E
93±1.0	52±1.0	4.8Max	160±5	4±2

## 3. WINDING:

STEP	START-FINISH	WIRE TYPE	TURNS	TAPE	REMARK
N1	S-F	∅ 0.08*105mm2UEW-F	9TS (Ref)		

## 4. ELECTRICAL SPECIFICATION:

ITEM	L1	L2	L3	HI-POT	
	100KHz, 0.25V	100KHz, 0.25V	100KHz, 0.25V		
SPEC	6.8uH±10%	6.8uH±10%	6.3uH±10%		

## 5. BILF OF MATERIAL:

NO.	ITEM	MATERIAL SPECIFICATION	MANUFACTURER	SGS NO.
1	Copper-clad wire	0.08*105	SHENZHEN JINMA NEW MATERIALS TECHNOLOGY	
2	Solder Bar	Solder Bar	QIAODO	
3	magnetic sheet	G46.5*52*2p Manganese zinc hard magnetic sheet	TAIYI CO.,LTD	
4	glue	Yellow Glue 9999	DONGGUANSHIGUOXISHIY EYOUXIANGONGS	
5	High-temperature adhesive paper	8mm Wide high-temperature adhesive paper	CUDAK CO.,LTD	
6	Gain	OdBi		

HRSW ELECTRONICS CO.,LTD

PART NO

TITLE