

# SPECIFICATION FOR APPROVAL

## 1.MECHANICAL DIMENSION (UNIT:mm)

## 2. SCHEMATICS:

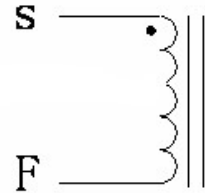
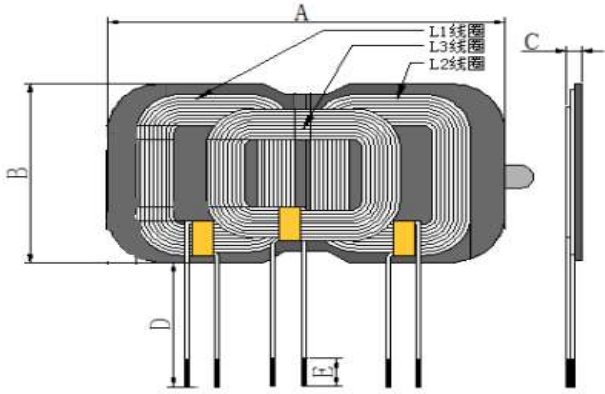

### 1.Coil attached disk, disk size

93\*52mm two sorts

.Coil outlet position wrap tape paper  
1-2Ts;

3. The bottom of the magnetic separator should be affixed with back glue

A	B	C	D	E
93±1.0	52±1.0	4.8Max	160±5	4±2

## 3.WINDING:

STEP	START-FINISH	WIRE TYPE	TURNS	TAPE	REMARK
N1	S-F	∅0.08*105mm2UEW-F	9TS (Ref)		

## 4. ELECTRICAL SPECIFICATION:

ITEM	L1	L2	L3	HI-POT	
TEST	Coil and diskette	Coil and diskette	Coil and diskette		
CON	100KHz, 0.25V	100KHz, 0.25V	100KHz, 0.25V		
SPEC	6.8uH±10%	6.8uH±10%	6.3uH±10%		

## 5.BILF OF MATERIAL:

NO.	ITEM	MATERIAL SPECIFICATION	MANUFACTURER	SGS NO.
1	Acrylic copper silk-covered wire	0.08*105股	SHENZHEN JINMA NEW MATERIALS TECHNOLOGY CO LTD	深圳市金马新材料科技有限公司
2	Lead-free tin strip	Lead-free tin strip	QIAODO	东莞千岛有限公司
3	magnetic sheet	G46.5*52*2pManganese zinc hard disk	TAIYI CO.,LTD	东莞台一实业有限公司
4	glue	黄胶9999	DONGGUANSHIGUOXISHIYEYOUXIANGONGS	东莞国喜实业有限公司
5	high-temperature adhesive tape	8mmWide high temperature adhesive paper	CUDAK CO.,LTD	

## 6.ANTENNA GAIN:

0dBi		
HRSW ELECTRONICS CO.,LTD	PART NO	
	TITLE	A6 Three-coil lead 160mm
DRAWN BY	CHECKED BY	APPROVED BY
Weihua He	Lihong Wei	Lihong Wei