

## SENSERT Base Unit - Cellular product description

Product Name: SENSERT Base Unit - Cellular

Model No.: SST-BCA1HH

Manufacturer: Automatic Timing and Controls Diversified Electronics

Address of Manufacturer: 8019 Ohio River Blvd, PO Box 305, Newell, WV 26050 USA



# SENSERT™



## SENSERT Base Unit Specifications

<b>Power Supply</b>	5-30 V DC	
<b>Analog Inputs</b>	4 - 0-20 mA, 4-20 mA, 0-5 V, 0- 10 V	
<b>Digital Inputs</b>	2 - Dry Contact or NPN Type	
<b>Digital Output</b>	1 - Relay (240 VAC, 5A)	
<b>Internal Measurements</b>	Temperature and Humidity	
<b>Analog Channel Impedance</b>	mA: 200 ohm V: 1M ohm	
<b>Digital Inputs</b>	<b>Type</b>	Dry Contact or NPN Type
	<b>Logic Levels</b>	Logical Level "0": From 0 to 0.5 V DC Logical Level "1": From 3 to 30 V DC
	<b>Maximum Voltage</b>	12 V DC
	<b>Input Impedance</b>	500k ohm
	<b>Input Current @ 12 VDC (Typical)</b>	24uA
	<b>Maximum Frequency (Square Wave)</b>	Dry Contact: 500 Hz NPN: 500 Hz
	<b>Minimum Pulse Duration</b>	Dry Contact: 2 ms NPN: 2 ms
<b>Resolution</b>	4096 (12 bit A DC)	
<b>Report Interval</b>	Configurable	
<b>Alerts</b>	Configurable through the SENSERT Mobile App or Web Portal. Each channel can be configured for a high and low threshold value as well as custom alerts.	
<b>Operation Temp</b>	-4 to 131°F (-20 to 55°C)	
<b>Accuracy</b>	1% for all inputs, 2% for internal measurements	
<b>Communication</b>	RS485 [FUTURE DEVELOPMENT]	

<b>Cellular</b>	Band	LTE-FDD: B2/B4/B12
	Antenna Gain	<=3dBi
	Mode	Cat-M1
<b>Bluetooth</b>	Cat	Bluetooth 5.0 Single Band
	Modulation type	GFSK
	Antenna Gain	0dBi

### FCC statement

This device complies with Part 15 of the FCC rules. Operation is subject to the following two conditions:

1) This device may not cause interference.

2) This device must accept any interference, including interference that may cause undesired operation

of the device.

Note: This equipment has been tested and found to comply with the limits for a Class B digital device, pursuant to part 15 of the FCC Rules. These limits are designed to provide reasonable protection against harmful interference in a residential installation. This equipment generates uses and can radiate radio frequency energy and, if not installed and used in accordance with the instructions, may cause harmful interference to radio communications. However, there is no guarantee that interference will not occur in particular installation. If this equipment does cause harmful interference to radio or television reception, which can be determined by turning the equipment off and on, the user is encouraged to try to correct the interference by one or more of the following measures:

--Reorient or relocate the receiving antenna.

--Increase the separation between the equipment and receiver.

--Connect the equipment into an outlet on a circuit different from that to which the receiver is connected.

--Consult the dealer or an experienced radio/TV technician for help.

Changes or modifications not expressly approved by the party responsible for compliance could void the user's authority to operate the equipment.

FCC Radiation Exposure Statement This device complies with FCC RF radiation exposure limits set forth for an uncontrolled environment. This transmitter must not be co-located or operating in conjunction with any other antenna or transmitter.

## SENSERT Base Unit Diagram

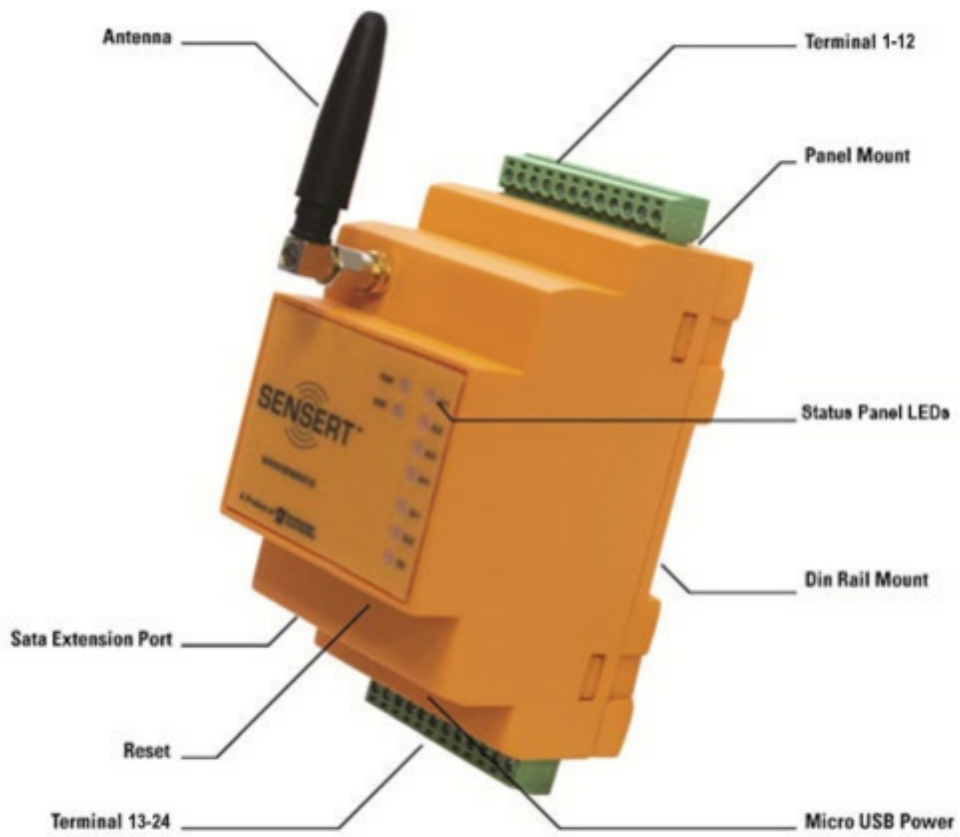

## SENSERT Power and Status LEDs



### **PWR:** Power LED

*Green:* Indicates the power supply is in normal status.

*Red:* Startup or in process of firmware update.

### **STAT:** Status LED

*Green:* Base unit connected to the SENSERT Cloud Server.

*Red:* Base unit is not connected to cellular network.

*Green (Flashing):* Base unit is connected to a cat-m1 network, but not connected to the SENSERT Cloud Server.

### **AI1-AI4:** Analog Inputs

*On/Green:* Channel active and in normal status.

*On/Red:* Channel active and in alarm status.

*Off:* Channel inactive.

### **DI-1 - DI2:** Digital Inputs

*On/Green:* Channel active and in normal status.

*On/Red:* Channel active and in alert status.

*Off:* Channel inactive.

### **DO:** Digital Output

*On/Green:* Channel active and in normal status.

*On/Red:* Channel active and in alert status.

*Off:* Channel inactive.

## SENSERT Setup (cont.)

### Powering SENSERT

SENSERT is able to be powered 5-30 V DC. See diagram below.

The 4-20 mA input from the sensor cannot be floating with the power supply that is used for the SENSERT Base Unit. The max common mode voltage of the AI +/- to the GND of DC power must be 0-24 V.

The floating 4-20 mA AI input might damage the SENSERT Base Unit.

#### **Option 1: 4-20mA 3/4 wire sensor**

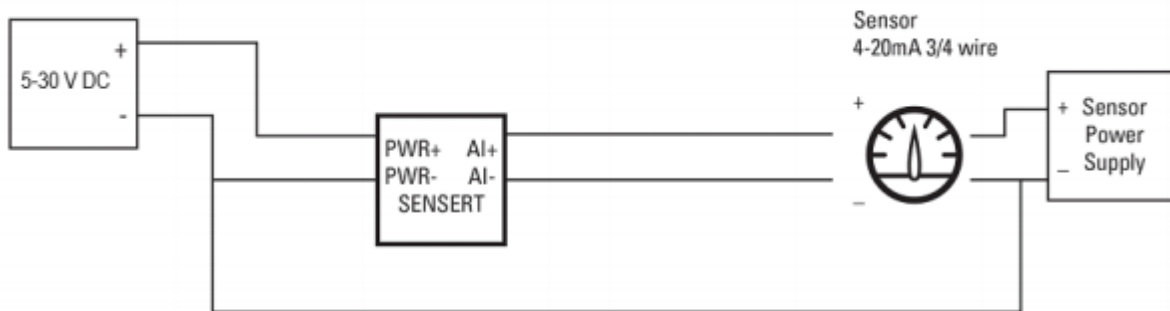

The sensor's 4-20 mA 3/4 wire supply need to share the same negative net with SENSERT power negative net.

#### **Option 2: 4-20mA 2-wire sensor**

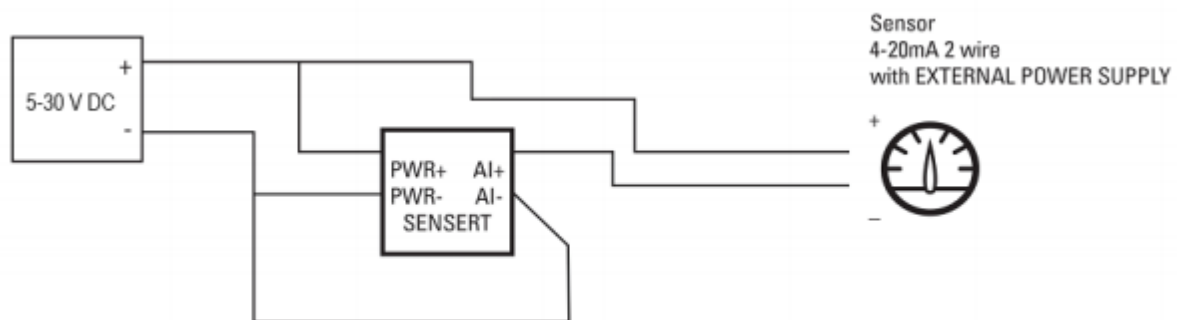

## SENSERT Setup (cont.)

### Connecting to Bluetooth

Download the SENSERT Mobile App available in the Google Play or Apple App Store and log in using the credentials you used to register your account. After logging into your new SENSERT account, navigate to: **Configuration → Device** to add a new SENSERT device.

Input the serial number of the SENSERT Base Unit, located on the underside of the SENSERT device. Please make sure that your Bluetooth connections are enabled on your phone at this time. If the device has not previously been added to an account, it will automatically connect.

If the unit does not automatically connect, please see the troubleshooting section to reset the Bluetooth Mesh.

### Analog Input Channel Setup

Each analog channel can be enabled or disabled in the configuration screen. If enabled, enter the following information:

**Name:**

User-defined name of the analog channel

**Input Sensor Type:**

Select from 0- 10 V, 0-5 V, 4-20 mA, and NTC.

**Analog:**

Select the type of sensor from the drop-down menu.

**Unit:**

Define the unit for the sensor output data.

**Zero & Span:**

Define the zero and span for the channel data for the display.

**Report Intervals:** The interval of the data updated on the cloud, but if the channel data has no changes larger than 0.05%, the data will not be reported.

**Alert:**

Choose the boundaries for the lower and upper limits for the notification alert.

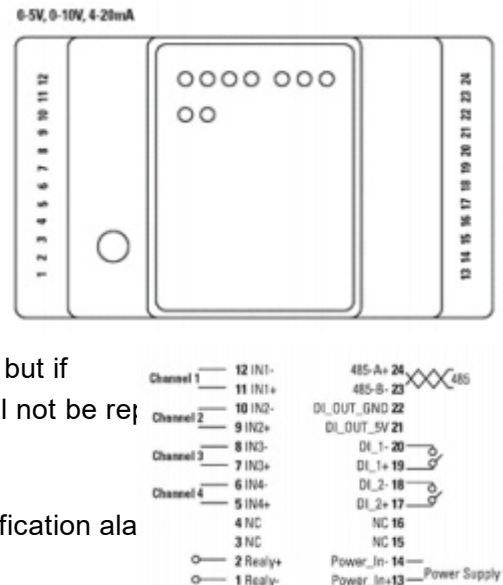

## **SENSERT Setup (cont.)**

### **Digital Input Channel Setup**

**Name:** User-defined name of the digital channel

**Report Intervals:**

The interval of the data updated on the cloud, but if the channel data has no changes of the status of the DI input, the data will not be re-reported to the cloud.

**Sensor Type:**

PNP, NPN, Dry Contact.

**Input Mode:**

DI input will be treated as digital input normally. The data will be 0 or 1. Counting input will count the times of pulse on the DI input pin during the report interval.

**Debounce:**

If the sensor type configured is *Dry Contact*, it is necessary to set a debounce time for edge detection. The debounce time is the sensor stabilization time - the minimum amount of time at which the sensor must remain at the logical level so that the detected edge is considered valid. The minimum configurable debounce time is 50 milliseconds and the maximum is 6 seconds.



## **Troubleshooting:**

Occasionally it may be necessary to reset the SENSERT Base Unit to re-enable connectivity.

### **Reset SENSERT Base Unit:**

Using a pin or paperclip reset the device using the inset rest button on the side of the SENSERT Base Unit. (See SENSERT Base Unit Diagram on page 2) Holding the reset pin for different durations determine the type of reset performed. (See below)

### **Reboot SENSERT Base Unit:**

Hold for 3 seconds until the Power LED flashes then release.

### **Reset Bluetooth Mesh:**

Hold for 6 seconds until the Status LED flashes, then release. In addition to the hardware reset, the user with the account will need to open the smart phone app, go to configuration then device and click reset here as well as the hardware base unit reset.

### **Reset Factory Settings:**

Hold for 9 seconds until both Power and Status LEDs flash, then release. For the user who has the SENSERT already in the account, need to go in smart phone app, go to configuration- device - click RESET to reset the mesh in the app too. **NOTE: This will reset the unit to Factory Settings.**

# Appendix A. Dimension Drawing

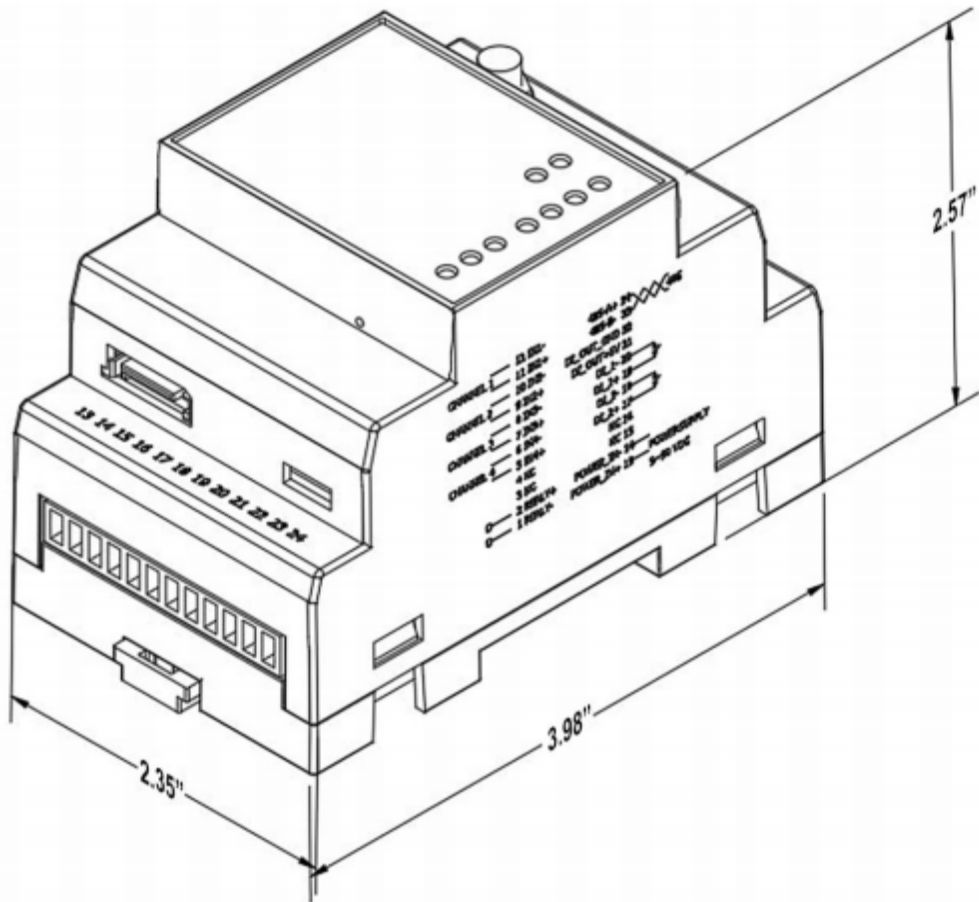

## **Terms and Conditions (cont.)**

### **Changes to Terms**

Marsh Bellofram reserves the right, in its sole discretion, to change the Terms under which [www.sensert.io](http://www.sensert.io) is offered. The most current version of the Terms will supersede all previous versions. Marsh Bellofram encourages you to periodically review the Terms to stay informed of our updates.

### **Contact Us**

Marsh Bellofram welcomes your questions or comments regarding the Terms:

Marsh Bellofram, Inc.  
8019 Ohio River Blvd  
Newell, West Virginia 26050

Email Address:  
[customerrfq@marshbellofram.com](mailto:customerrfq@marshbellofram.com)

Telephone number:  
304-387-1200

Effective as of January 01, 2020

:

#### FCC WARNING

This device complies with part 15 of the FCC Rules. Operation is subject to the following two conditions: (1) this device may not cause harmful interference, and (2) this device must accept any interference received, including interference that may cause undesired operation.

Any changes or modifications not expressly approved by the party responsible for compliance could void the user's authority to operate the equipment.

NOTE: This equipment has been tested and found to comply with the limits for a Class B digital device, pursuant to Part 15 of the FCC Rules. These limits are designed to provide reasonable protection against harmful interference in a residential installation. This equipment generates, uses and can radiate radio frequency energy and, if not installed and used in accordance with the instructions, may cause harmful interference to radio communications.

However, there is no guarantee that interference will not occur in a particular installation.

If this equipment does cause harmful interference to radio or television reception, which can be determined by turning the equipment off and on, the user is encouraged to try to correct the interference by one or more of the following measures:

- Reorient or relocate the receiving antenna.
- Increase the separation between the equipment and receiver.
- Connect the equipment into an outlet on a circuit different from that to which the receiver is connected.
- Consult the dealer or an experienced radio/TV technician for help.

To maintain compliance with FCC's RF Exposure guidelines, This equipment should be installed and operated with minimum 20cm distance between the radiator and your body: Use only the supplied antenna.