

TEST REPORT

Report Number.....:	90121-22-72-22-PP001	
Date of issue	Mar.02.2022	
Tested by (+signature)	Duke	<i>Duke Chen</i>
Approved by (+signature).....:	Jason	<i>Jason gao</i>
Testing Laboratory name.....:	SLG-CPC Testlaboratory Co., Ltd.	
Address	No. 11, Wu Song Road, Dongcheng District, Dongguan, Guangdong Province, China 523117	
Applicant's name	DongGuanShi WeizhiChuang Technology Co., Ltd	
Address	2/F, NO.3, Zhangyang Fuda 1st Road Zhangmutou Town,DongGuanShi	
Manufacturer's name	DongGuanShi WeizhiChuang Technology Co., Ltd	
Address	2/F, NO.3, Zhangyang Fuda 1st Road Zhangmutou Town,DongGuanShi	
Factory's name	DongGuanShi WeizhiChuang Technology Co., Ltd	
Address	2/F, NO.3, Zhangyang Fuda 1st Road Zhangmutou Town,DongGuanShi	
Standard(s).....:	FCC Rules and Regulations Part 15 Subpart C, Section 209	
Test item description.....:	Three-in-one Charger	
Trade Mark.....:	/	
Model/Type reference	W312	
FCC ID.....:	2A4WMWZC-W312	
Date of receipt of test item	Feb.16.2022	
Date (s) of performance of test:	Feb.16.2022 to Feb.26.2022	
Summary of Test Results.....:	Pass	
The Summary of Test Results based on a technical opinion belongs to the standard(s).		
General disclaimer:		
This report shall not be reproduced except in full, without the written approval of SLG-CPC Testlaboratory Co., Ltd. The test results in the report only apply to the tested sample.		

TABLE OF CONTENT

TABLE OF CONTENT	2
1. SUMMARY OF TEST RESULTS	3
2. GENERAL INFORMATION	4
2.1. DESCRIPTION OF DEVICE (EUT).....	4
2.2. INPUT / OUTPUT PORTS	4
2.3. INDEPENDENT OPERATION MODES	5
2.4. DESCRIPTION OF TEST FACILITY	5
2.5. DESCRIPTION OF SUPPORT DEVICE	6
2.6. MEASUREMENT UNCERTAINTY	6
3. MEASURING DEVICE AND TEST EQUIPMENT	7
3.1. MEASUREMENT EQUIPMENT USED	7
4. 20DB BANDWIDTH	8
4.1. TEST PROCEDURE	8
4.2. TEST RESULTS.....	8
5. POWER LINE CONDUCTED EMISSION MEASUREMENT	9
5.1. BLOCK DIAGRAM OF TEST SETUP	9
5.2. LIMITS.....	9
5.3. TEST PROCEDURE	9
5.4. MEASURING RESULTS	10
6. RADIATED EMISSION TEST	13
6.1. MEASUREMENT PROCEDURE	13
6.2. TEST SET-UP (BLOCK DIAGRAM OF CONFIGURATION)	13
6.3. RADIATED EMISSION LIMIT	14
6.4. MEASUREMENT RESULT	15

1. SUMMARY OF TEST RESULTS

EMISSION		
Description of Test Item	Standard & Limits	Results
Conducted Emission	FCC Part 15, Subpart C- Section 15.207 ANSI C63.10-2013	Pass
Radiated Emission	FCC Part 15, Subpart C- Section 15.209 ANSI C63.10-2013	Pass
20dB Bandwidth	FCC Part 15, Subpart C- Section 15.215 ANSI C63.10-2013	Pass
Note: N/A is an abbreviation for Not Applicable.		

2. GENERAL INFORMATION

2.1. Description of Device (EUT)

Product Name	Three-in-one Charger
Trade Name	/
Model Name	W312
Series Model	N/A
Output	Wireless Output1:15W/10W/7.5W Wireless Output2:5W Wireless Output3:2.5W(For iWatch)
Operation frequency	115-205KHz
Modulation Type	MSK
Antenna Type	Inductive Loop Antenna with 0dBi
Power Supply	Input: DC 5V or 9V form Adapter
Hardware version number	V1.0
Software version number	V1.0
Connecting I/O Port(s)	Please refer to the User's Manual

2.2. Input / Output Ports

Port #	Name	Type*	Cable Max. >3m	Cable Shielded	Comments
1	Enclosure	N/E	--	--	None
2	DC power	AC	No	Unshielded	1 ports
3	USB Out	DC	--	--	1 ports
* Note: For the purposes of the present document, the following symbols apply: AC AC Power Port DC DC Power Port N/E Non-Electrical I/O Signal Input or Output Port (Not Involved in Process Control) TP Telecommunication Ports					

2.3. Independent Operation Modes

Mode	TEST MODE DESCRIPTION
1.	AC/DC Adapter + EUT + Mobile Phone(15W) + Earphone (5W) + Watch (2.5W)
2.	AC/DC Adapter + EUT + Mobile Phone(15W) + Watch (2.5W)
3.	AC/DC Adapter + EUT + Mobile Phone(15W) + Earphone (5W)
4.	AC/DC Adapter + EUT + Watch (2.5W)
5.	AC/DC Adapter + EUT + Earphone (5W)
6.	AC/DC Adapter + EUT + Mobile Phone(7.5W)
7.	AC/DC Adapter + EUT + Mobile Phone(10W)
8.	AC/DC Adapter + EUT + Mobile Phone(15W)
Note: 1. All test modes were pre - tested, but we only recorded the worst case in this report.	

2.4. Description of Test Facility

Site Description

EMC Lab. :

Accredited by ISED, October 04 2021
 CAB identifier: CN0126
 Company Number: 27767
 Accredited by A2LA, October 04 2021
 The Certificate Registration Number is 6325.01

Name of Firm : SLG-CPC Testlaboratory Co., Ltd.
 Site Location : No. 11, Wu Song Road, Dongcheng District, Dongguan,
 Guangdong Province, China 523117

2.5. Description of Support Device

No.	Equipment	Trade name	Model	S/N	Power Cord
1.	Mobile phone	HUAWEI	Mare 30		
2.	Adapter	HUAWEI	HW-200675CD1		
3.	Watch	XIAOMI	DL03		
4.	Earphone	Airpors Pro	A2190		

2.6. Measurement Uncertainty

Test Item	Uncertainty
Occupied Channel Bandwidth	: $\pm 2.3\%$
Conducted Emission Uncertainty	: 3.08dB
Radiated Emission Uncertainty (3m Chamber)	: 3.60dB (30M~1GHz) 4.48dB (1~6GHz)

3. MEASURING DEVICE AND TEST EQUIPMENT

3.1. MEASUREMENT EQUIPMENT USED

Equipment	Model	Manufacturer	S/N	Cal. Due
RF Connected Test				
Vector Signal Generator	Rohde & Schwarz	SMBV100B(6G)	101166	2022/07/30
Analog Signal Generator	Rohde & Schwarz	SMB100A(40G)	181333	2022/07/30
Signal Analyzer	Rohde & Schwarz	FSV40	101527	2022/05/24
Power Analyzer	Rohde & Schwarz	OSP-B157W8	N/A	2022/09/23
Wideband Radio Communication Tester	R&S	CMW270	101985	2022/07/30
Temperature&Humidity test chamber	ESPEC	VC 4018	/	2022/04/02
Wideband Radio Communication Tester	Rohde & Schwarz	CMW500	166898	2022/09/07
Radiated Emission Test				
EMI Test Receiver	KEYSIGHT	N9010A	MY56070465	2022/12/10
EMI Test Receiver	Rohde & Schwarz	FSV40	101511	2022/05/24
Bilog Antenna	Schwarzbeck	VULB 9163	01335	2023/04/28
Power Amplifier	EMEC	EM330	060676	2022/12/10
Cable	Tuyue	F4309	L-400-NmNm-12000	2022/12/10
Signal Analyzer	Rohde & Schwarz	FSV40	101511	2022/05/24
Horn Antenna	Schwarzbeck	BBHA9170	/	2022/10/09
Power Amplifier	Rohde & Schwarz	SCU-18F	180118	2022/05/17
Active Loop Antenna	ETS LINDGREN	6512	41623	2022/04/26
Test Software	Farad	EZ-EMC	Ver.CPC-3A1	/
Conducted Emission Test				
LISN	Schwarzbeck	NSLK 8127	8127-892	2022/03/19
EMI Test Receiver	R&S	ESR3	102124	2022/12/10
Pulse Limiter	R&S	ESH3-Z2	357.8810.52	2022/12/10
Test Software	Farad	EZ-EMC	Ver.CPC-3A1	/

4. 20DB BANDWIDTH

4.1. Test Procedure

Set to the maximum power setting and enable the EUT transmit continuously
 Set RBW = 10KHz.
 Set the video bandwidth (VBW) =30KHz.
 Set Span= 100KHz
 Set Detector = Peak.
 Set Trace mode = max hold.
 Set Sweep = auto couple.
 Measure and record the results in the test report.

4.2. Test Results

Temperature: 24°C
 Humidity: 53 %

Test Date: Feb. 25, 2022
 Test By: Ken

20dB Band=28.08kHz

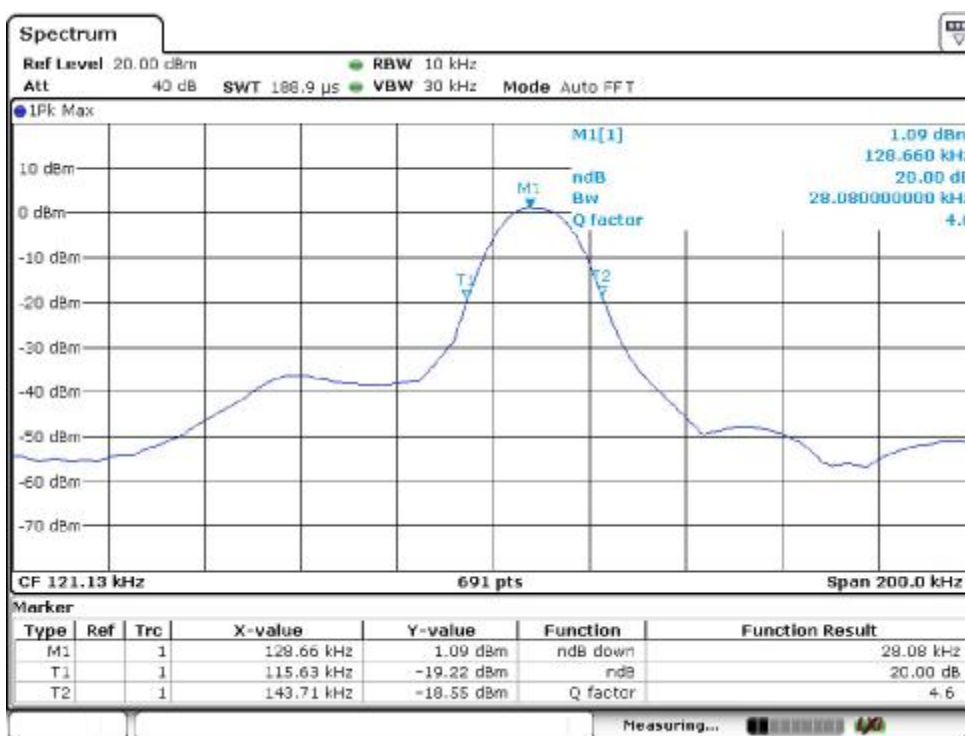

5. POWER LINE CONDUCTED EMISSION MEASUREMENT

5.1. Block Diagram of Test Setup

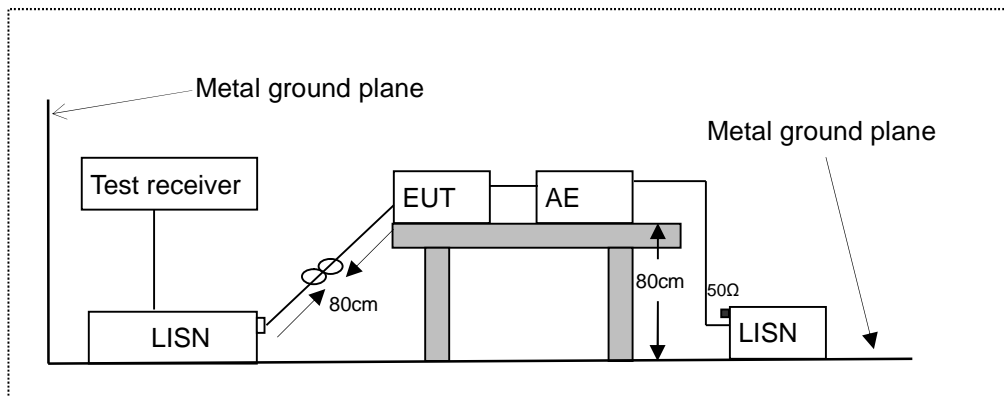

LISN: Line Impedance Stabilization Network
 AE: Associated equipment
 EUT: Equipment under test

5.2. Limits

FCC Part 15.207

Frequency (MHz)	Limit (dB μ V)	
	Quasi-peak Level	Average Level
0.15 ~ 0.50	66.0 ~ 56.0 *	56.0 ~ 46.0 *
0.50 ~ 5.00	56.0	46.0
5.00 ~ 30.00	60.0	50.0

NOTE1-The lower limit shall apply at the transition frequencies.
 NOTE2-The limit decreases linearly with the logarithm of the frequency in the range 0.15MHz to 0.50MHz.

5.3. Test Procedure

The EUT was placed on a desk 0.8 m height from the metal ground plane and 0.4 m from the conducting wall of the shielding room and it was kept at least 0.8 m from any other grounded conducting surface. The size of the table will nominally be 1.5 m x1.0 m.

The rear of the arrangement shall be flush with the back of the supporting tabletop unless that would not be possible or typical of normal use.

All units of equipment forming the system under test (includes the EUT as well as connected peripherals and associated equipment or devices) shall be arranged such that a nominal 0.1 m separation is achieved between the neighboring units.

Connect EUT to the power mains through a line impedance stabilization network (LISN). Where the mains cable supplied by the manufacturer is longer than 1 m, the excess should be folded at the centre into a bundle no longer than 0.4 m, so that its length is shortened to 1 m.

All the support units are connecting to the other LISN.

The LISN provides 50 ohm coupling impedance for the measuring instrument.

Both sides of AC line were checked for maximum conducted interference.

The frequency range from 150 kHz to 30 MHz was sweep.

Set the test-receiver system to quasi peak detect function and average detect function, and to measure the conducted emissions values.

Test results were obtained from the following equation:

Emission Level (dB μ V) = LISN Factor (dB) + Cable Loss (dB) + Reading (dB μ V)

Margin (dB) = Emission Level (dB μ V) - Limit (dB μ V)

5.4. Measuring Results

PASS.

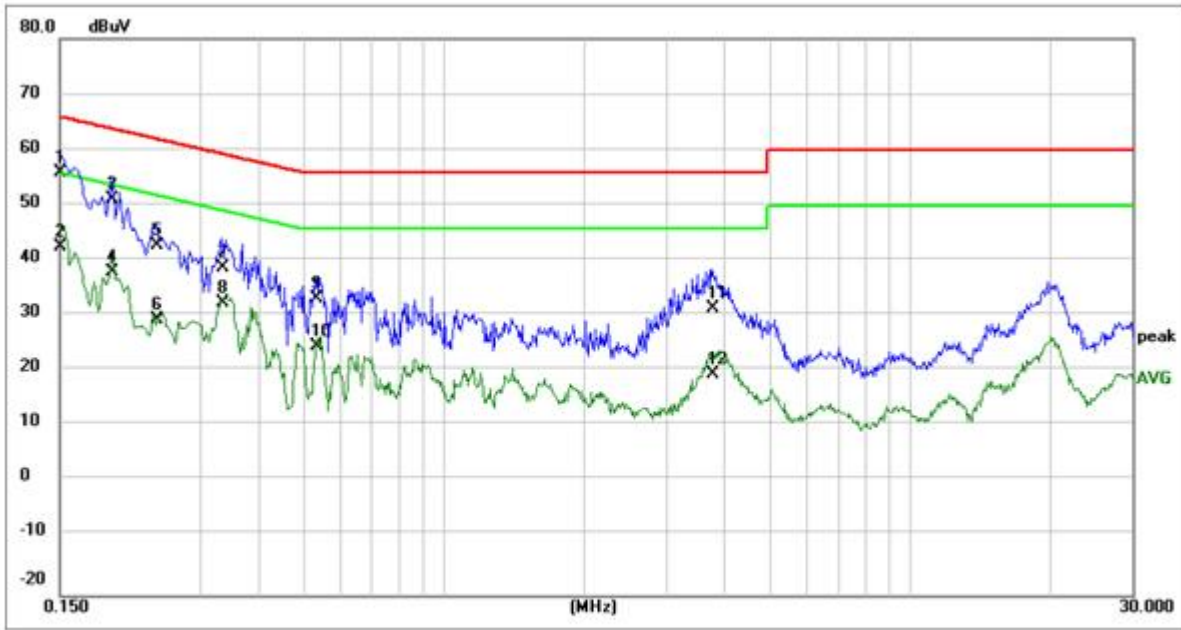

Site:	Phase:L1	Temperature(C):24(C)
Limit: FCC Part 15C Conduction(QP)		Humidity(%):53%
M/N.: W312	Power Rating: AC120V/60Hz	
Mode: Wireless Charge	Test Engineer: Ken	
Note:		

No.	Frequency (MHz)	Reading Level(dBuV)	Factor (dB)	Measurement(dBuV)	Limit (dBuV)	Margin (dB)	Detector	Comment
1 *	0.1505	45.91	10.00	55.91	65.97	-10.06	QP	
2	0.1505	32.80	10.00	42.80	55.97	-13.17	AVG	
3	0.1940	39.52	11.71	51.23	63.86	-12.63	QP	
4	0.1940	26.57	11.71	38.28	53.86	-15.58	AVG	
5	0.2420	30.96	11.92	42.88	62.03	-19.15	QP	
6	0.2420	17.67	11.92	29.59	52.03	-22.44	AVG	
7	0.3339	27.01	11.88	38.89	59.35	-20.46	QP	
8	0.3339	20.71	11.88	32.59	49.35	-16.76	AVG	
9	0.5340	21.43	11.89	33.32	56.00	-22.68	QP	
10	0.5340	12.94	11.89	24.83	46.00	-21.17	AVG	
11	3.7620	21.61	9.94	31.55	56.00	-24.45	QP	
12	3.7620	9.78	9.94	19.72	46.00	-26.28	AVG	

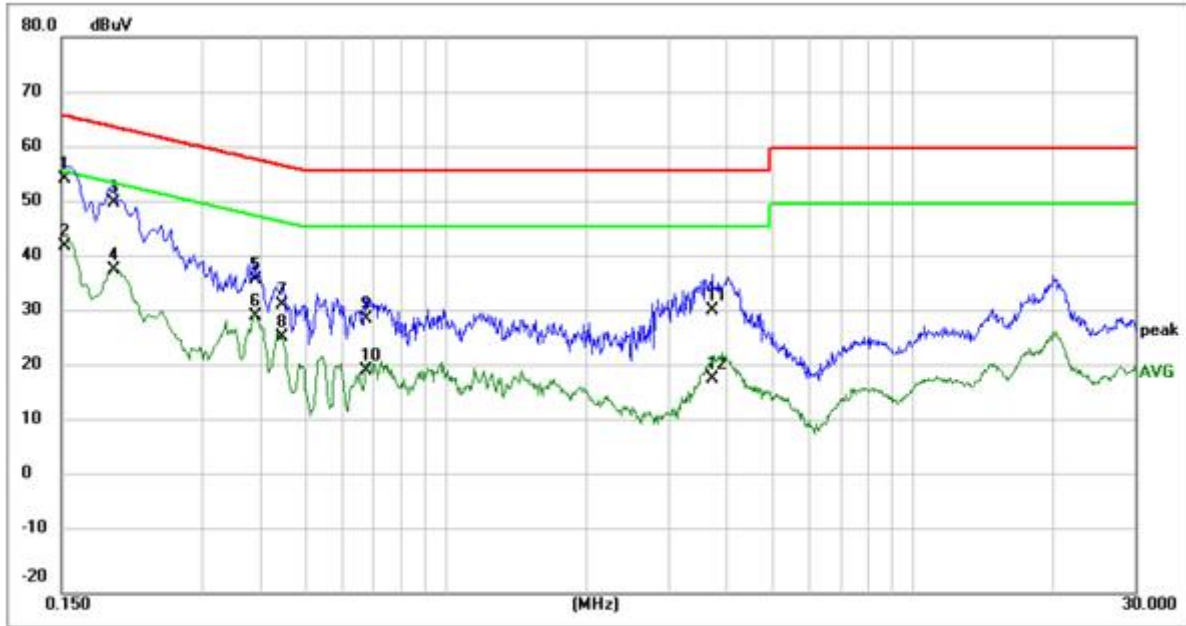

Site:		Phase:N	Temperature(C):24(C)
Limit:	FCC Part 15C Conduction(QP)		Humidity(%):53%
M/N.:	W312	Power Rating:	AC120V/60Hz
Mode:	Wireless Charge	Test Engineer:	Ken
Note:			

No.	Frequency (MHz)	Reading Level(dBuV)	Factor (dB)	Measurement(dBuV)	Limit (dBuV)	Margin (dB)	Detector	Comment
1 *	0.1516	44.51	10.05	54.56	65.91	-11.35	QP	
2	0.1516	32.48	10.05	42.53	55.91	-13.38	AVG	
3	0.1940	38.49	11.71	50.20	63.86	-13.66	QP	
4	0.1940	26.49	11.71	38.20	53.86	-15.66	AVG	
5	0.3899	24.43	11.89	36.32	58.07	-21.75	QP	
6	0.3899	17.98	11.89	29.87	48.07	-18.20	AVG	
7	0.4460	19.87	11.89	31.76	56.95	-25.19	QP	
8	0.4460	14.16	11.89	26.05	46.95	-20.90	AVG	
9	0.6740	17.57	11.89	29.46	56.00	-26.54	QP	
10	0.6740	8.31	11.89	20.20	46.00	-25.80	AVG	
11	3.7300	20.89	9.94	30.83	56.00	-25.17	QP	
12	3.7300	8.64	9.94	18.58	46.00	-27.42	AVG	

6. RADIATED EMISSION TEST

6.1. Measurement Procedure

1. The EUT was placed on a turn table which is 0.8m above ground plane.
2. Maximum procedure was performed on the six highest emissions to ensure EUT compliance.
3. And also, each emission was to be maximized by changing the polarization of receiving antenna both horizontal and vertical.
4. Repeat above procedures until all frequency measured were complete.
5. Use the following receiver/spectrum analyzer settings:
 Span = wide enough to fully capture the emission being measured
 RBW=200Hz for 9KHz to 150KHz,
 RBW=9kHz for 150KHz to 30MHz,
 RBW=120KHz for 30MHz to 1GHz
 VBW ≥ 3*RBW
 Sweep = auto
 Detector function = QP
 Trace = max hold

6.2. Test SET-UP (Block Diagram of Configuration)

(A) Radiated Emission Test Set-Up, Frequency Below 30MHz

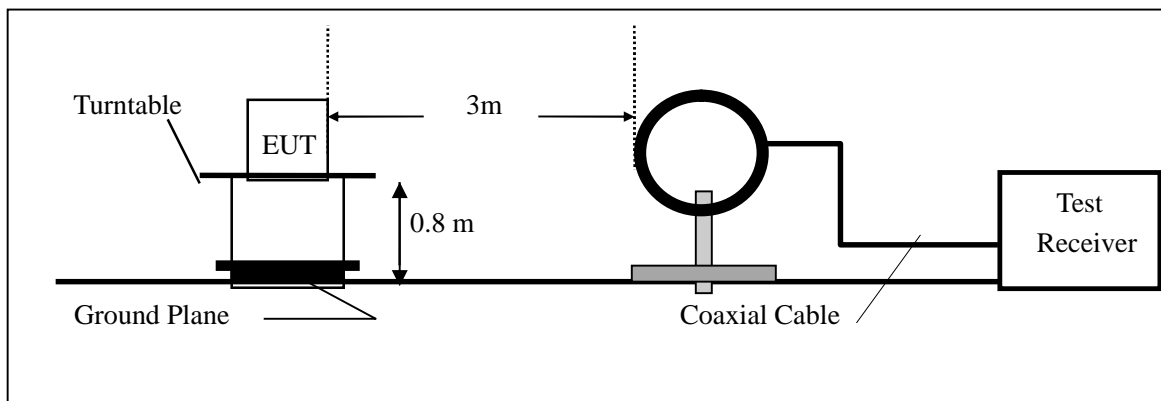

(B) Radiated Emission Test Set-Up, Frequency Below 1000MHz

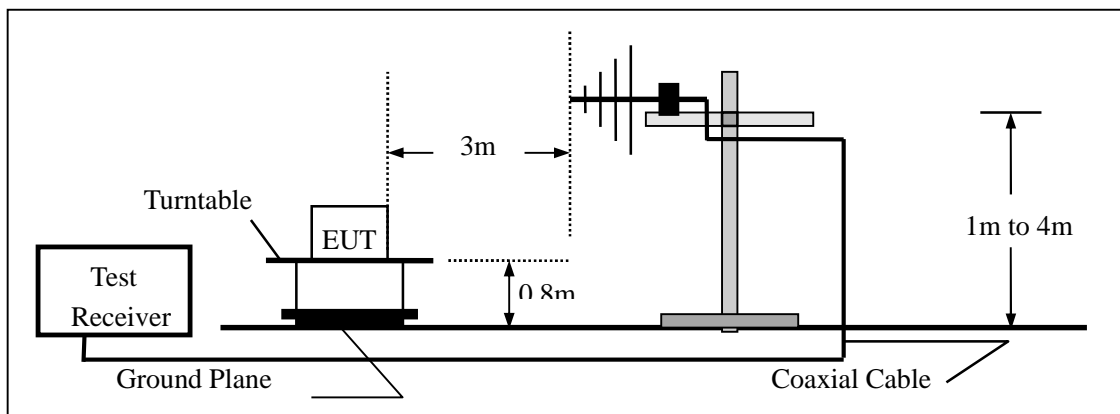

6.3. Radiated Emission Limit

The emissions from an intentional radiator shall not exceed the field strength levels specified in the following table 15.209(a):

FCC Part 15.209				
Frequency (MHz)	Field Strength Limitation		Field Strength Limitation Frequency tion at 3m Measurement Dist	
	(uV/m)	Dist	(uV/m)	(dBuV/m)
0.009 – 0.490	2400 / F(KHz)	300m	10000 * 2400/F(KHz)	20log 2400/F(KHz) + 80
0.490 – 1.705	24000 / F(KHz)	30m	100 * 24000/F(KHz)	20log 24000/F(KHz) + 40
1.705 – 30.00	30	30m	100* 30	20log 30 + 40
30.0 – 88.0	100	3m	100	20log 100
88.0 – 216.0	150	3m	150	20log 150
216.0 – 960.0	200	3m	200	20log 200
Above 960.0	500	3m	500	20log 500

15.205 Restricted bands of operation

MHz	MHz	MHz	GHz
0.090 - 0.110	16.42 - 16.423	399.9 - 410	4.5 - 5.15
¹ 0.495 - 0.505	16.69475 - 16.69525	608 - 614	5.35 - 5.46
2.1735 - 2.1905	16.80425 - 16.80475	960 - 1240	7.25 - 7.75
4.125 - 4.128	25.5 - 25.67	1300 - 1427	8.025 - 8.5
4.17725 - 4.17775	37.5 - 38.25	1435 - 1626.5	9.0 - 9.2
4.20725 - 4.20775	73 - 74.6	1645.5 - 1646.5	9.3 - 9.5
6.215 - 6.218	74.8 - 75.2	1660 - 1710	10.6 - 12.7
6.26775 - 6.26825	108 - 121.94	1718.8 - 1722.2	13.25 - 13.4
6.31175 - 6.31225	123 - 138	2200 - 2300	14.47 - 14.5
8.291 - 8.294	149.9 - 150.05	2310 - 2390	15.35 - 16.2
8.362 - 8.366	156.52475 - 156.52525	2483.5 - 2500	17.7 - 21.4
8.37625 - 8.38675	156.7 - 156.9	2690 - 2900	22.01 - 23.12
8.41425 - 8.41475	162.0125 - 167.17	3260 - 3267	23.6 - 24.0
12.29 - 12.293	167.72 - 173.2	3332 - 3339	31.2 - 31.8
12.51975 - 12.52025	240 - 285	3345.8 - 3358	36.43 - 36.5
12.57675 - 12.57725	322 - 335.4	3600 - 4400	(²)

- Remark:
1. Emission level in dBuV/m=20 log (uV/m)
 2. Measurement was performed at an antenna to the closed point of EUT distance of meters.
 3. Only spurious frequency is permitted to locate within the Restricted Bands specified in provision of § 15.205, and the emissions located in restricted bands also comply with 15.209 limit.

6.4.Measurement Result

9kHz-150kHz:

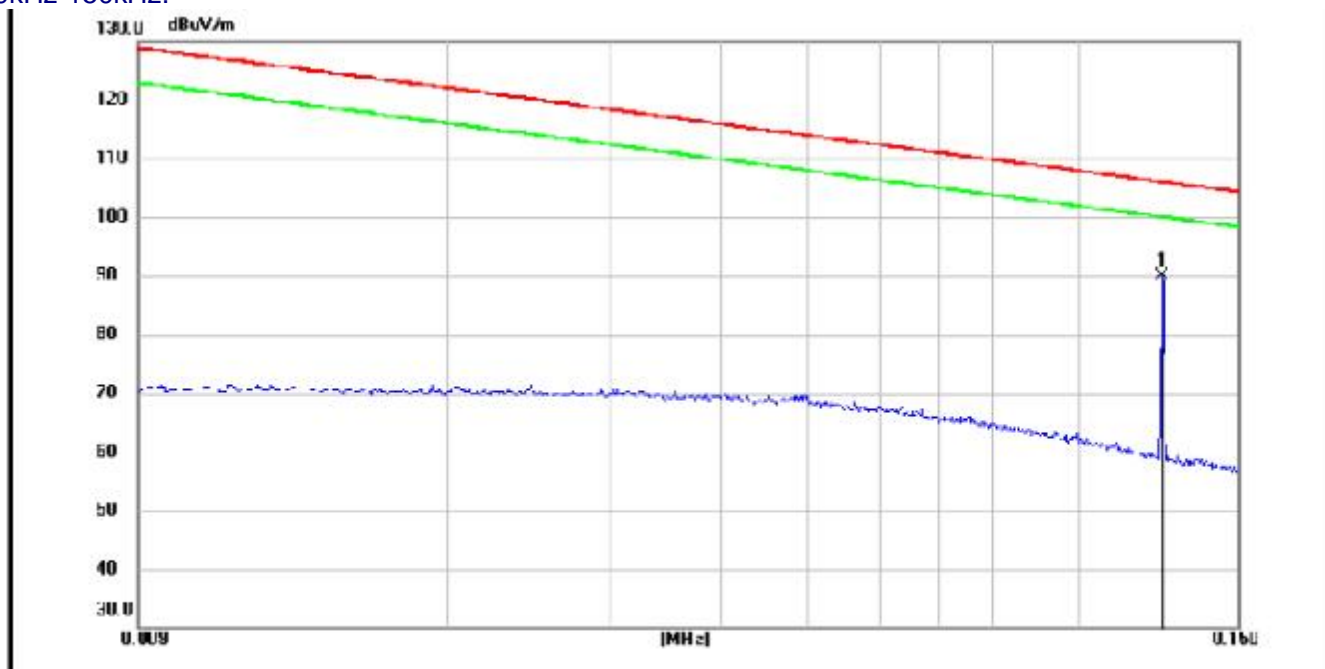

Site aaa	Polarization: Vertical	Temperature: 23.4(C)
Limit: FCC Part15.209 9k-30M	Power: AC 120 V/60 Hz	Humidity: 47 %RH

Mode: Wireless Charging
Note:

No.	Frequency (MHz)	Reading (dBuV)	Factor (dB/m)	Level (dBuV/m)	Limit (dBuV/m)	Margin (dB)	Detector				
1	0.123700	75.98	13.79	89.77	105.99	-16.22	peak				

*:Maximum data x:Over limit !:over margin

150kHz-30MHz:

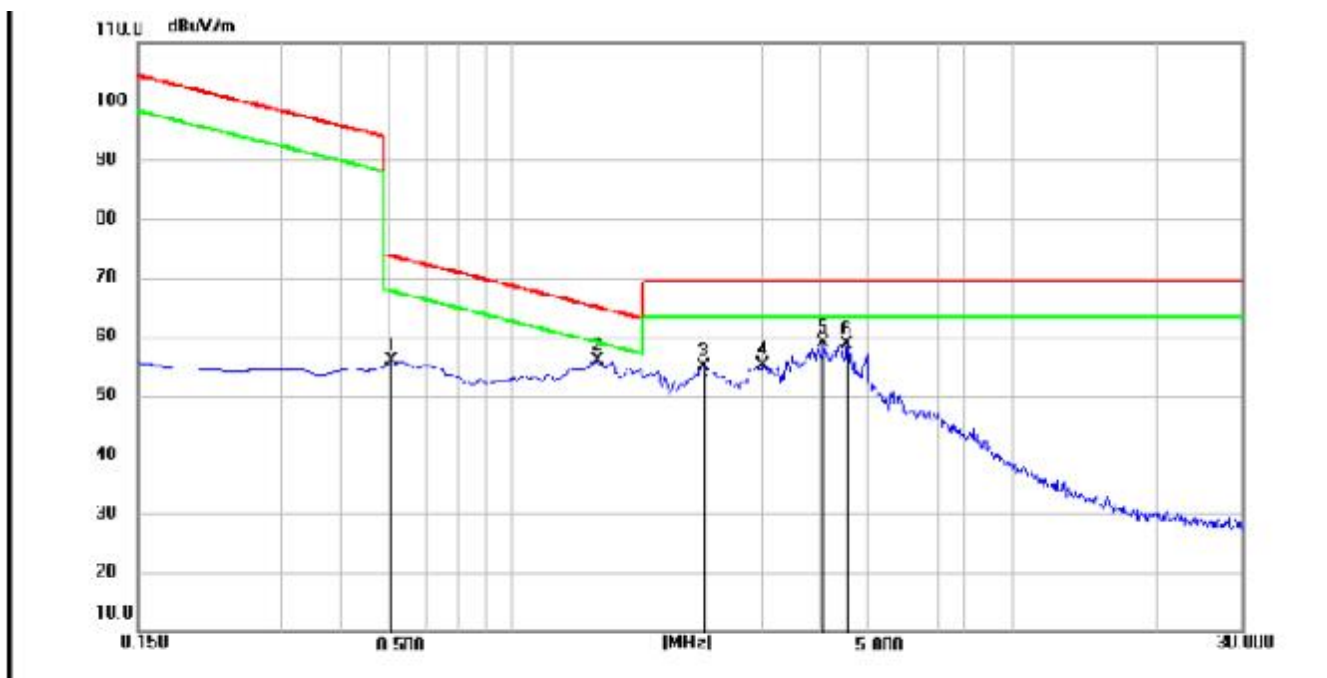

Site aaa

Polarization: **Vertical**

Temperature: 23.4(C)

Limit: FCC Part15.209 9k-30M

Power: AC 120 V/60 Hz

Humidity: 47 %RH

Mode: Wireless Charging

Note:

No.	Frequency (MHz)	Reading (dBuV)	Factor (dB/m)	Level (dBuV/m)	Limit (dBuV/m)	Margin (dB)	Detector				
1	0.508000	53.51	2.26	55.77	73.68	17.91	peak				
2	1.366500	61.78	-5.88	55.90	64.95	-0.05	peak				
3	2.269200	64.46	-9.65	54.81	69.50	-14.69	peak				
4	3.015600	66.89	-11.83	55.06	69.50	-14.44	peak				
5	4.030400	73.26	-14.38	58.88	69.50	-10.62	peak				
6	4.508000	73.79	-15.11	58.68	69.50	-10.82	peak				

^:Maximum data x:Over limit !:over margin

30MHz-1GHz:



Site:		Antenna: Vertical	Temperature(C): 24.5(C)
Limit:	FCC Part 15C Radiation(QP)		Humidity(%): 55%
M/N.:	W312	Power Rating:	AC120V/60Hz
Mode:	Wireless Charge	Test Engineer:	Ken
Note:			

No.	Frequency (MHz)	Reading (dBuV)	Factor (dB/m)	Level (dBuV/m)	Limit (dBuV/m)	Margin (dB)	Det.			
1	30.0000	27.52	0.38	27.90	40.00	-12.10	peak			
2 *	39.9942	37.52	-5.03	32.49	40.00	-7.51	QP			
3	100.9339	33.57	-4.72	28.85	43.50	-14.65	peak			
4	128.5630	26.42	-3.25	23.17	43.50	-20.33	peak			
5	210.0482	27.67	-6.87	20.80	43.50	-22.70	peak			
6	362.9844	27.20	-2.74	24.46	46.00	-21.54	peak			

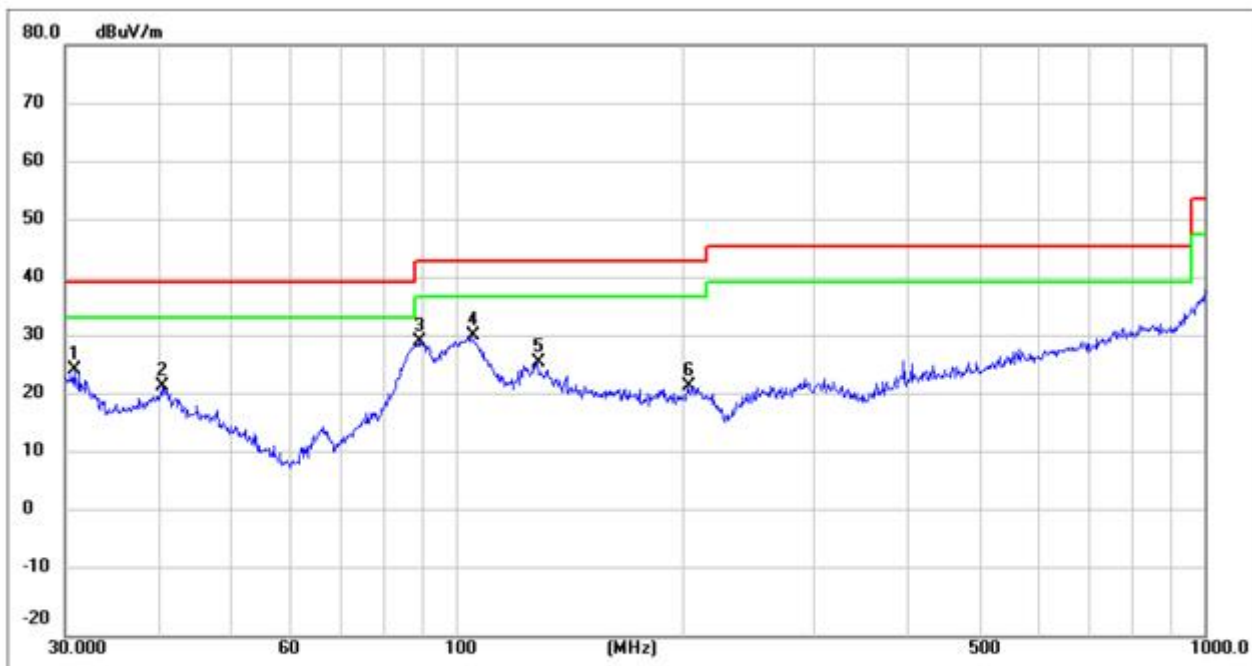

Site:		Antenna::Horizontal	Temperature(C):24.5(C)
Limit:	FCC Part 15C Radiation(QP)		Humidity(%):55%
M/N.:	W312	Power Rating:	AC120V/60Hz
Mode:	Wireless Charge	Test Engineer:	Ken
Note:			

No.	Frequency (MHz)	Reading (dBuV)	Factor (dB/m)	Level (dBuV/m)	Limit (dBuV/m)	Margin (dB)	Det.			
1	30.8535	25.56	-0.55	25.01	40.00	-14.99	peak			
2	40.5591	27.46	-5.23	22.23	40.00	-17.77	peak			
3	89.5899	38.89	-8.96	29.93	43.50	-13.57	peak			
4 *	104.9033	35.26	-4.48	30.78	43.50	-12.72	peak			
5	128.5630	29.70	-3.25	26.45	43.50	-17.05	peak			
6	203.5228	29.43	-6.99	22.44	43.50	-21.06	peak			

-----The end-----