

TEST REPORT

Report Number:	90956-22-72-22-PP001	
Date of issue	2022-11-02	
Tested by (+signature)	Duke	<i>Duke Chen</i>
Approved by (+signature):	Jason	<i>Jason gao</i>
Testing Laboratory name:	SLG-CPC Testlaboratory Co., Ltd.	
Address	No. 11, Wu Song Road, Dongcheng District, Dongguan, Guangdong Province, China 523117	
Applicant's name:	DongGuanShi WeizhiChuang Technology Co., Ltd	
Address	Room 801, Building 5, No.1, Fengjing Road, Daping, Tangxia Town, Dongguan City, Guangdong Province	
Manufacturer's name	DongGuanShi WeizhiChuang Technology Co., Ltd	
Address	Room 801, Building 5, No.1, Fengjing Road, Daping, Tangxia Town, Dongguan City, Guangdong Province	
Factory's name	DongGuanShi WeizhiChuang Technology Co., Ltd	
Address	Room 801, Building 5, No.1, Fengjing Road, Daping, Tangxia Town, Dongguan City, Guangdong Province	
Standard(s):	FCC Rules and Regulations Part 15 Subpart C, Section 209	
Test item description:	2 in 1 Wireless Charger	
Trade Mark:	UCOMX, RTOPS	
Model/Type reference:	W203	
FCC ID:	2A4WMWZC-W203	
Date of receipt of test item	2022-10-20	
Date (s) of performance of test:	2022-10-21 to 2022-10-30	
Summary of Test Results:	Pass	
The Summary of Test Results based on a technical opinion belongs to the standard(s).		
General disclaimer:		
This report shall not be reproduced except in full, without the written approval of SLG-CPC Testlaboratory Co., Ltd. The test results in the report only apply to the tested sample.		

TABLE OF CONTENT

TABLE OF CONTENT	2
1. SUMMARY OF TEST RESULTS	4
2. GENERAL INFORMATION.....	5
2.1. DESCRIPTION OF DEVICE (EUT).....	5
2.2. INPUT / OUTPUT PORTS	5
2.3. INDEPENDENT OPERATION MODES	6
2.4. DESCRIPTION OF TEST FACILITY	6
2.5. DESCRIPTION OF SUPPORT DEVICE	7
2.6. MEASUREMENT UNCERTAINTY	7
3. MEASURING DEVICE AND TEST EQUIPMENT	8
3.1. MEASUREMENT EQUIPMENT USED	8
4. 20DB BANDWIDTH	9
4.1. TEST PROCEDURE	9
4.2. TEST RESULTS.....	9
5. POWER LINE CONDUCTED EMISSION MEASUREMENT	11
5.1. BLOCK DIAGRAM OF TEST SETUP	11
5.2. LIMITS.....	11
5.3. TEST PROCEDURE	11
5.4. MEASURING RESULTS	12
6. RADIATED EMISSION TEST	15
6.1. MEASUREMENT PROCEDURE	15
6.2. TEST SET-UP (BLOCK DIAGRAM OF CONFIGURATION)	15
6.3. RADIATED EMISSION LIMIT	16
6.4. MEASUREMENT RESULT	17
7. ANTENNA APPLICATION.....	21
7.1. ANTENNA REQUIREMENT.....	21
7.2. RESULT	21

Modified Information

Report No.	Revision Data	Summary
90956-22-72-22-PP001	2022-11-02	Original Version

1. SUMMARY OF TEST RESULTS

EMISSION		
Description of Test Item	Standard & Limits	Results
Conducted Emission	FCC Part 15, Subpart C- Section 15.207 ANSI C63.10-2013	Pass
Radiated Emission	FCC Part 15, Subpart C- Section 15.209 ANSI C63.10-2013	Pass
20dB Bandwidth	FCC Part 15, Subpart C- Section 15.215 ANSI C63.10-2013	Pass
Note: N/A is an abbreviation for Not Applicable.		

2. GENERAL INFORMATION

2.1. Description of Device (EUT)

Product Name	2 in 1 Wireless Charger
Trade Name	UCOMX, RTOPS
Model Name	W203
Series Model	/
Output	Wireless Output 1: 10W/7.5W/5W for Phone Wireless Output 2: 2.5W for iWatch
Operation frequency	115-205kHz for Phone 327kHz for iWatch
Modulation Type	MSK
Antenna Type	Inductive Loop Antenna with 0dBi
Power Supply	Input: DC 5V 3A, 9V 2A
Hardware version number	V1.0
Software version number	V1.0
Connecting I/O Port(s)	Please refer to the User's Manual

2.2. Input / Output Ports

Port #	Name	Type*	Cable Max. >3m	Cable Shielded	Comments
1	Enclosure	N/E	--	--	None
2	DC power	AC	No	Unshielded	1 ports
* Note: For the purposes of the present document, the following symbols apply: AC AC Power Port DC DC Power Port N/E Non-Electrical I/O Signal Input or Output Port (Not Involved in Process Control) TP Telecommunication Ports					

2.3. Independent Operation Modes

Mode:	TEST MODE DESCRIPTION
1	EUT + Wireless Output (Phone 10W) + Wireless Output (iWatch 2.5W)
2	EUT + Wireless Output (Phone 10W)
3	EUT + Wireless Output (Phone 7.5W)
4	EUT + Wireless Output (Phone 5W)
5	EUT + Wireless Output (iWatch 2.5W)
Note:	
1. All test modes were pre - tested, but we only recorded the worst case in this report. The worst case is mode 1	

2.4. Description of Test Facility

Site Description

EMC Lab. : Accredited by ISED, October 04 2021
 CAB identifier: CN0126
 Company Number: 27767
 Accredited by A2LA, October 04 2021
 The Certificate Registration Number is 6325.01

Name of Firm : SLG-CPC Testlaboratory Co., Ltd.
 Site Location : No. 11, Wu Song Road, Dongcheng District, Dongguan,
 Guangdong Province, China 523117

2.5. Description of Support Device

No.	Equipment	Trade name	Model	S/N	Power Cord
1.	Cellphone	iPhone	IPhone12		
2	Adapter	HUAWEI	HW-200675CD1		
3	Watch	iPhone	S8		

2.6. Measurement Uncertainty

Test Item	Uncertainty
Occupied Channel Bandwidth	: $\pm 2.3\%$
Conducted Emission Uncertainty	: 3.08dB
Radiated Emission Uncertainty	:
(3m Chamber)	3.46dB (0.009MHz~30MHz)
	3.60dB (30MHz~1GHz)
	4.48dB (1~6GHz)

3. MEASURING DEVICE AND TEST EQUIPMENT

3.1. MEASUREMENT EQUIPMENT USED

Equipment	Manufacturer	Model	S/N	Last Cal.	DUE Cal.
RF Connected Test					
Vector Signal Generator	Rohde & Schwarz	SMBV100B(6G)	101166	2022/06/29	1 year
Analog Signal Generator	Rohde & Schwarz	SMB100A(40G)	181333	2022/06/29	1 year
Signal Analyzer	Rohde & Schwarz	FSV40	101527	2022/04/19	1 year
Power Analyzer	Rohde & Schwarz	OSP-B157W8	N/A	2022/06/29	1 year
Wideband Radio Communication Tester	R&S	CMW270	101985	2022/07/05	1 year
Wideband Radio Communication Tester	Rohde & Schwarz	CMW500	166898	2022/07/14	1 year
Temperature&Humidity test chamber	ESPEC	VC 4018	/	2022/03/23	1 year
Radiated Emission Test					
EMI Test Receiver	KEYSIGHT	N9010A	MY56070465	2021/12/10	1 year
EMI Test Receiver	Rohde & Schwarz	FSV40	101511	2022/04/19	1 year
Bilog Antenna	Schwarzbeck	VULB 9163	01335	2020/04/28	3 year
Power Amplifier	EMEC	EM330	060676	2021/12/10	3 year
Cable	Tuyue	F4309	L-400-NmNm-12000	2021/12/10	1 year
Horn Antenna	Schwarzbeck	BBHA9120D	1779	2022/04/21	3 year
Horn Antenna	Schwarzbeck	BBHA9170	00954	2022/09/13	3 year
Power Amplifier	Rohde & Schwarz	SCU-18F	180118	2022/04/21	3 year
Active Loop Antenna	ETS LINDGREN	6512	41623	2022/04/23	3 year
Test Software	Farad	EZ-EMC	Ver.CPC-3A1	/	/
Conducted Emission Test					
LISN	Schwarzbeck	NSLK 8127	8127-892	2022/03/19	1 year
LISN	Schwarzbeck	NSLK 8127	8127-437	2022/08/26	1 year
EMI Test Receiver	R&S	ESR3	102124	2021/12/10	1 year
Pulse Limiter	R&S	ESH3-Z2	357.8810.52	2021/12/10	1 year
Test Software	Farad	EZ-EMC	Ver.CPC-3A1	/	/

4. 20DB BANDWIDTH

4.1. Test Procedure

Set to the maximum power setting and enable the EUT transmit continuously
 Set RBW = 300Hz.
 Set the video bandwidth (VBW) =1kHz.
 Set Span= 7kHz
 Set Detector = Peak.
 Set Trace mode = max hold.
 Set Sweep = auto couple.
 Measure and record the results in the test report.

4.2. Test Results

Temperature: 24°C Test Date: 2022-10-09
 Humidity: 53 % Test By: Ken

Frequency 327kHz 20dB Band=861Hz

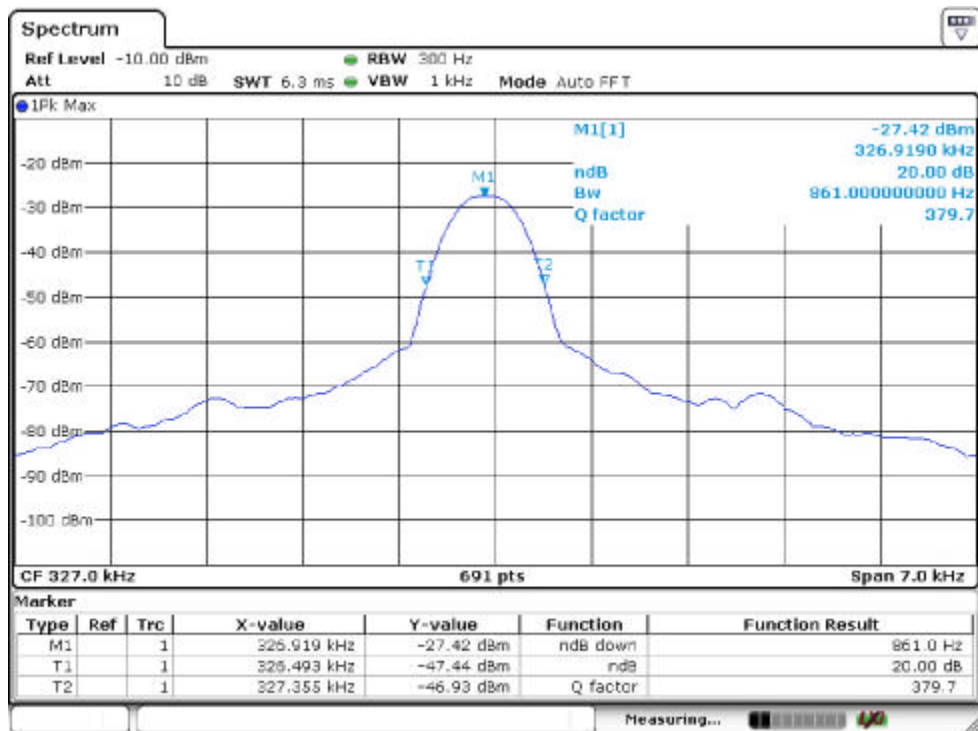

Frequency 115-205kHz 20dB Band=942Hz

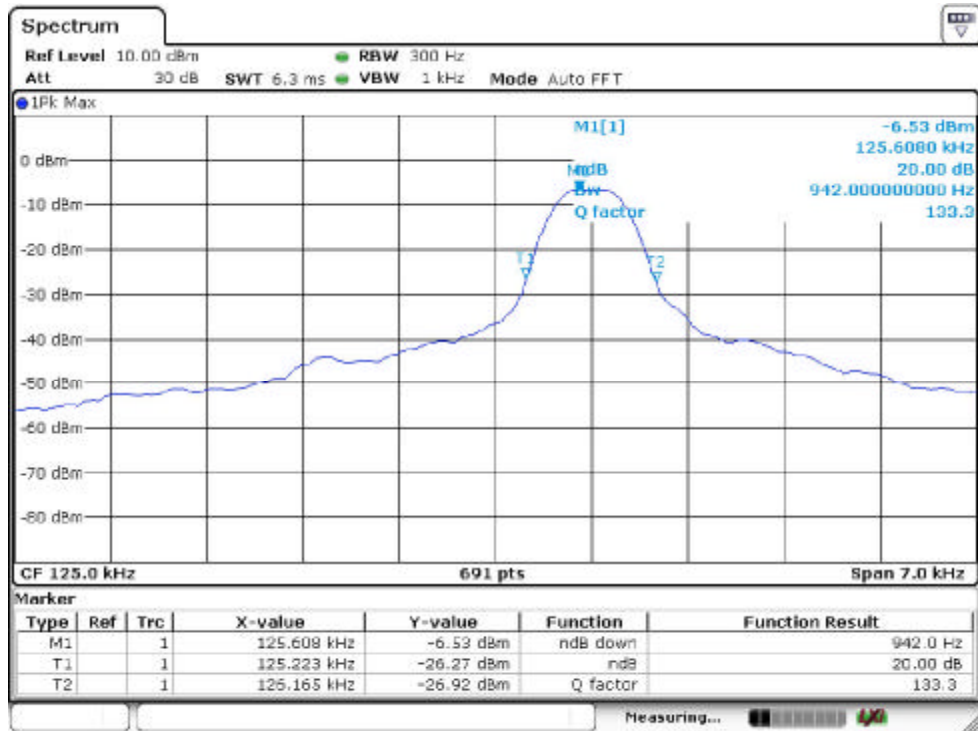

5. POWER LINE CONDUCTED EMISSION MEASUREMENT

5.1. Block Diagram of Test Setup

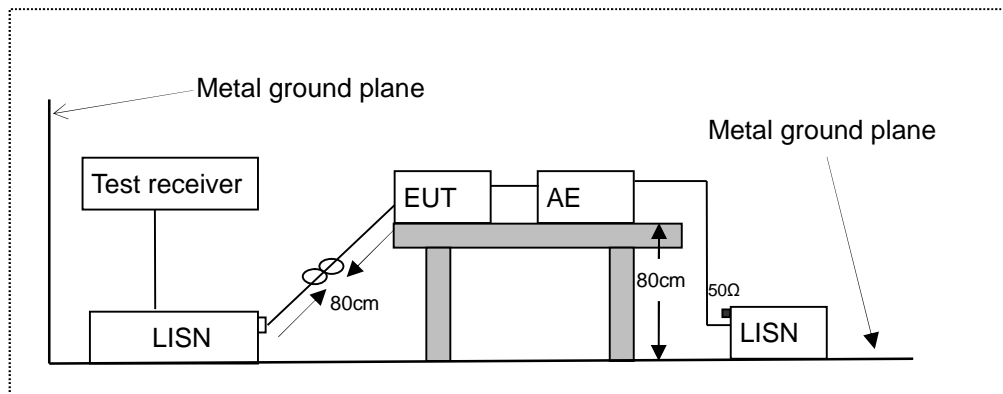

LISN: Line Impedance Stabilization Network

AE: Associated equipment

EUT: Equipment under test

5.2. Limits

FCC Part 15.207

Frequency (MHz)	Limit (dB μ V)	
	Quasi-peak Level	Average Level
0.15 ~ 0.50	66.0 ~ 56.0 *	56.0 ~ 46.0 *
0.50 ~ 5.00	56.0	46.0
5.00 ~ 30.00	60.0	50.0

NOTE1-The lower limit shall apply at the transition frequencies.
 NOTE2-The limit decreases linearly with the logarithm of the frequency in the range 0.15MHz to 0.50MHz.

5.3. Test Procedure

The EUT was placed on a desk 0.8 m height from the metal ground plane and 0.4 m from the conducting wall of the shielding room and it was kept at least 0.8 m from any other grounded conducting surface. The size of the table will nominally be 1.5 m x1.0 m.

The rear of the arrangement shall be flush with the back of the supporting tabletop unless that would not be possible or typical of normal use.

All units of equipment forming the system under test (includes the EUT as well as connected peripherals and associated equipment or devices) shall be arranged such that a nominal 0.1 m separation is achieved between the neighboring units.

Connect EUT to the power mains through a line impedance stabilization network (LISN). Where the mains cable supplied by the manufacturer is longer than 1 m, the excess should be folded at the centre into a bundle no longer than 0.4 m, so that its length is shortened to 1 m.

All the support units are connecting to the other LISN.

The LISN provides 50 ohm coupling impedance for the measuring instrument.

Both sides of AC line were checked for maximum conducted interference.

The frequency range from 150 kHz to 30 MHz was sweep.

Set the test-receiver system to quasi peak detect function and average detect function, and to measure the conducted emissions values.

Test results were obtained from the following equation:

Emission Level (dB μ V) = LISN Factor (dB) + Cable Loss (dB) + Reading (dB μ V)

Margin (dB) = Emission Level (dB μ V) - Limit (dB μ V)

5.4. Measuring Results

PASS.

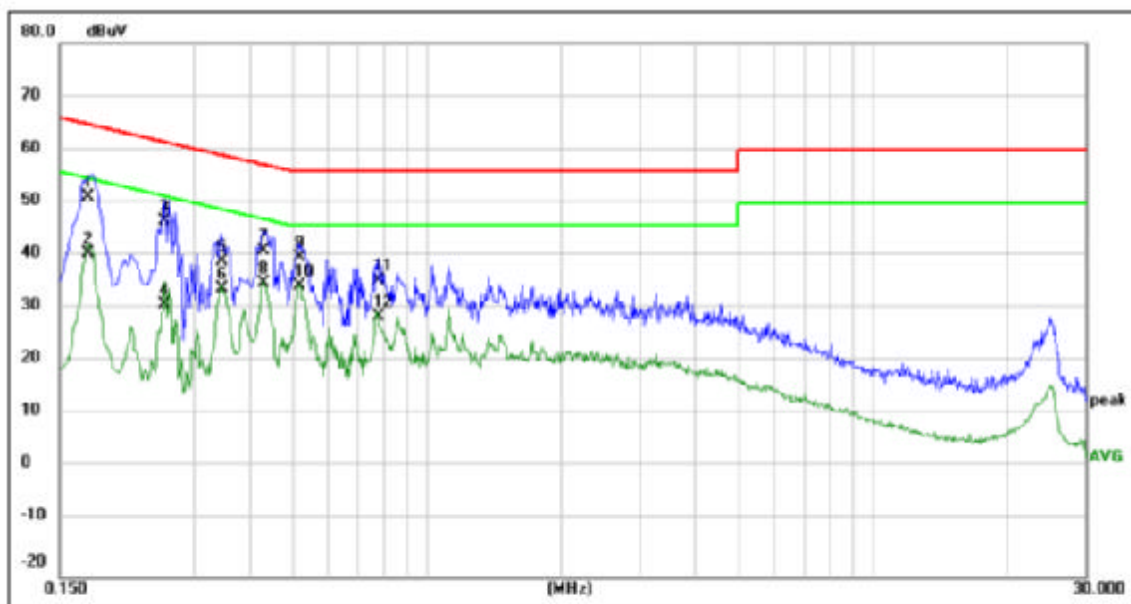

Site:	Phase:L1	Temperature(C):26(C)
Limit: FCC Part 15C Conduction(QP)		Humidity(%):60%
M/N.: W203	Power Rating: AC 120 V/60 Hz	
Mode: Wireless Charge	Test Engineer: Ken	
Note:		

No.	Frequency (MHz)	Reading Level(dBuV)	Factor (dB)	Measurement(dBuV)	Limit (dBuV)	Margin (dB)	Detector	Comment
1	0.1737	40.52	10.75	51.27	64.78	-13.51	QP	
2	0.1737	29.85	10.75	40.60	54.78	-14.18	AVG	
3	0.2580	34.92	11.85	46.77	61.50	-14.73	QP	
4	0.2580	19.33	11.85	31.18	51.50	-20.32	AVG	
5	0.3460	27.28	11.88	39.16	59.06	-19.90	QP	
6	0.3460	22.29	11.88	34.17	49.06	-14.89	AVG	
7	0.4300	29.29	11.89	41.18	57.25	-16.07	QP	
8	0.4300	23.35	11.89	35.24	47.25	-12.01	AVG	
9	0.5180	28.11	11.89	40.00	56.00	-16.00	QP	
10 *	0.5180	22.75	11.89	34.64	46.00	-11.36	AVG	
11	0.7780	23.70	11.88	35.58	56.00	-20.42	QP	
12	0.7780	17.05	11.88	28.93	46.00	-17.07	AVG	

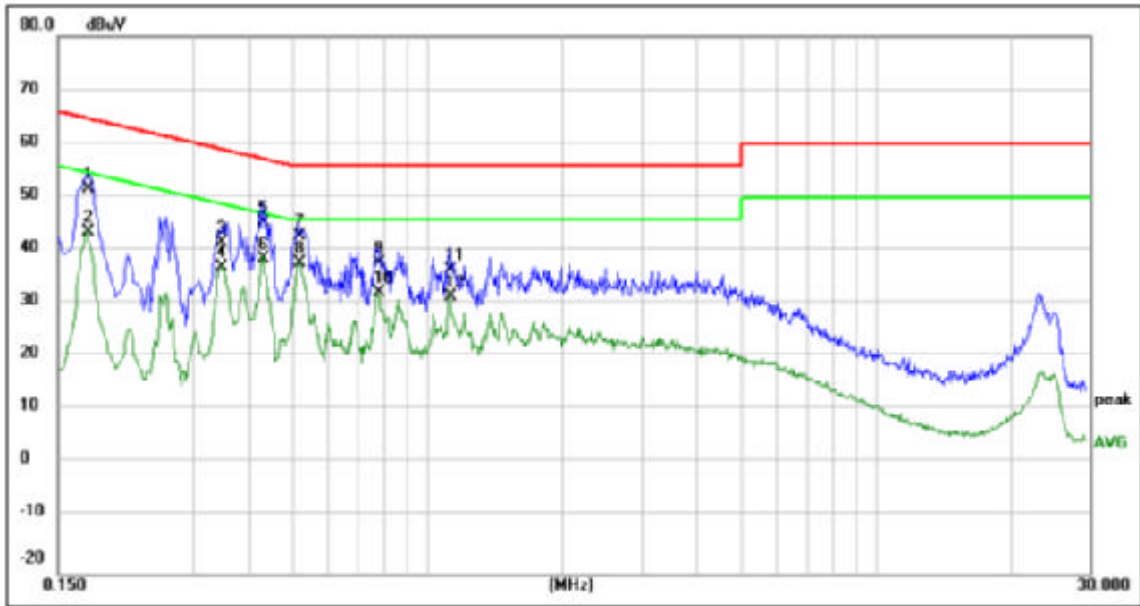

Site:	Phase:N	Temperature(C):26(C)
Limit: FCC Part 15C Conduction(QP)		Humidity(%):60%
M/N.: W203	Power Rating: AC 120 V/60 Hz	
Mode: Wireless Charge	Test Engineer: Ken	
Note:		

No.	Frequency (MHz)	Reading Level(dBuV)	Factor (dB)	Measurement(dBuV)	Limit (dBuV)	Margin (dB)	Detector	Comment
1	0.1740	40.89	10.76	51.65	64.77	-13.12	QP	
2	0.1740	32.81	10.76	43.57	54.77	-11.20	AVG	
3	0.3483	29.91	11.88	41.79	59.00	-17.21	QP	
4	0.3483	25.22	11.88	37.10	49.00	-11.90	AVG	
5	0.4300	33.66	11.89	45.55	57.25	-11.70	QP	
6	0.4300	26.86	11.89	38.75	47.25	-8.50	AVG	
7	0.5180	30.95	11.89	42.84	56.00	-13.16	QP	
8 *	0.5180	26.03	11.89	37.92	46.00	-8.08	AVG	
9	0.7780	26.01	11.88	37.89	56.00	-18.11	QP	
10	0.7780	20.51	11.88	32.39	46.00	-13.61	AVG	
11	1.1220	24.96	11.76	36.72	56.00	-19.28	QP	
12	1.1220	19.87	11.76	31.63	46.00	-14.37	AVG	

6. RADIATED EMISSION TEST

6.1. Measurement Procedure

1. The EUT was placed on a turn table which is 0.8m above ground plane.
2. Maximum procedure was performed on the six highest emissions to ensure EUT compliance.
3. And also, each emission was to be maximized by changing the polarization of receiving antenna both horizontal and vertical.
4. Repeat above procedures until all frequency measured were complete.
5. Use the following receiver/spectrum analyzer settings:
 Span = wide enough to fully capture the emission being measured
 RBW=200Hz for 9KHz to 150KHz,
 RBW=9kHz for 150KHz to 30MHz,
 RBW=120KHz for 30MHz to 1GHz
 VBW $\geq 3 \times$ RBW
 Sweep = auto
 Detector function = QP
 Trace = max hold

6.2. Test SET-UP (Block Diagram of Configuration)

(A) Radiated Emission Test Set-Up, Frequency Below 30MHz

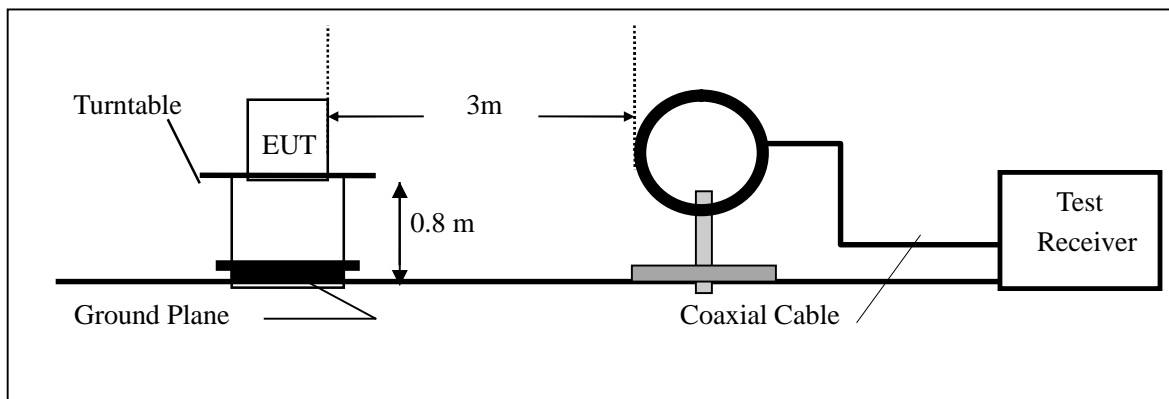

(B) Radiated Emission Test Set-Up, Frequency Below 1000MHz

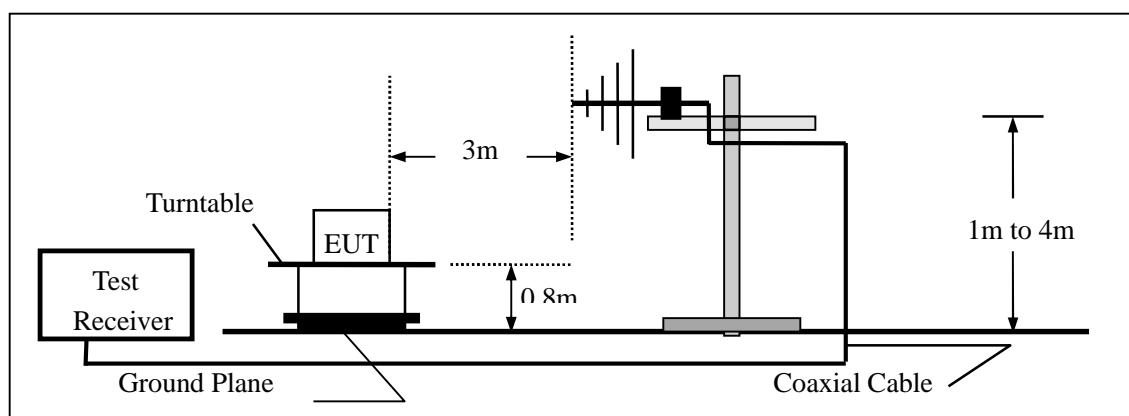

6.3. Radiated Emission Limit

The emissions from an intentional radiator shall not exceed the field strength levels specified in the following table 15.209(a):

FCC Part 15.209				
Frequency (MHz)	Field Strength Limitation		Field Strength Limitation Frequency tion at 3m Measurement Dist	
	(uV/m)	Dist	(uV/m)	(dBuV/m)
0.009 – 0.490	2400 / F(KHz)	300m	10000 * 2400/F(KHz)	20log 2400/F(KHz) + 80
0.490 – 1.705	24000 / F(KHz)	30m	100 * 24000/F(KHz)	20log 24000/F(KHz) + 40
1.705 – 30.00	30	30m	100* 30	20log 30 + 40
30.0 – 88.0	100	3m	100	20log 100
88.0 – 216.0	150	3m	150	20log 150
216.0 – 960.0	200	3m	200	20log 200
Above 960.0	500	3m	500	20log 500

15.205 Restricted bands of operation

MHz	MHz	MHz	GHz
0.090 - 0.110	16.42 - 16.423	399.9 - 410	4.5 - 5.15
0.495 - 0.505	16.69475 - 16.69525	608 - 614	5.35 - 5.46
2.1735 - 2.1905	16.80425 - 16.80475	960 - 1240	7.25 - 7.75
4.125 - 4.128	25.5 - 25.67	1300 - 1427	8.025 - 8.5
4.17725 - 4.17775	37.5 - 38.25	1435 - 1626.5	9.0 - 9.2
4.20725 - 4.20775	73 - 74.6	1645.5 - 1646.5	9.3 - 9.5
6.215 - 6.218	74.8 - 75.2	1660 - 1710	10.6 - 12.7
6.26775 - 6.26825	108 - 121.94	1718.8 - 1722.2	13.25 - 13.4
6.31175 - 6.31225	123 - 138	2200 - 2300	14.47 - 14.5
8.291 - 8.294	149.9 - 150.05	2310 - 2390	15.35 - 16.2
8.362 - 8.366	156.52475 - 156.52525	2483.5 - 2500	17.7 - 21.4
8.37625 - 8.38675	156.7 - 156.9	2690 - 2900	22.01 - 23.12
8.41425 - 8.41475	162.0125 - 167.17	3260 - 3267	23.6 - 24.0
12.29 - 12.293	167.72 - 173.2	3332 - 3339	31.2 - 31.8
12.51975 - 12.52025	240 - 285	3345.8 - 3358	36.43 - 36.5
12.57675 - 12.57725	322 - 335.4	3600 - 4400	(²)

- Remark:
1. Emission level in dBuV/m=20 log (uV/m)
 2. Measurement was performed at an antenna to the closed point of EUT distance of meters.
 3. Only spurious frequency is permitted to locate within the Restricted Bands specified in provision of § 15.205, and the emissions located in restricted bands also comply with 15.209 limit.

6.4.Measurement Result

9kHz-150kHz:

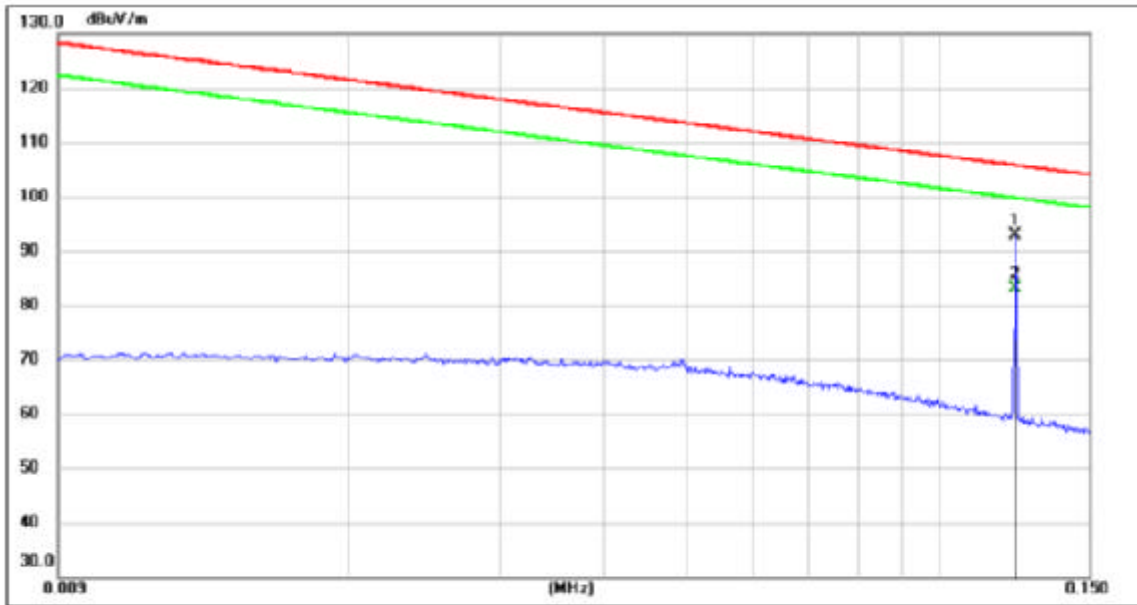

Site:		Antenna:Vertical	Temperature(C): 23.4(C)
Limit:	FCC Part15.209 9k-30M		Humidity(%): 47%RH
M/N.:	W203	Power Rating:	AC 120 V/60 Hz
Mode:	Wireless Charge	Test Engineer:	Ken
Note:			

No.	Frequency (MHz)	Reading (dBuV)	Correct (dB/m)	Result (dBuV/m)	Limit (dBuV/m)	Margin (dB)	Remark
1	0.122800	78.98	13.87	92.85	105.82	-12.97	peak
2	0.122800	69.45	13.87	83.32	105.82	-22.50	AVG

150kHz-30MHz:

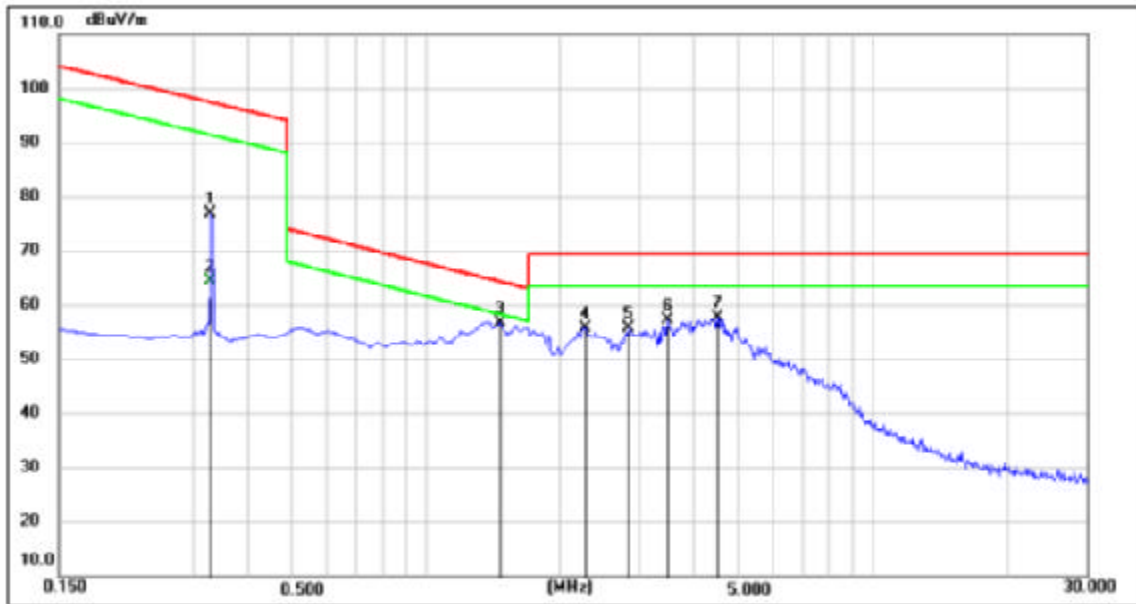

Site:		Antenna: Vertical	Temperature(C): 23.4(C)
Limit:	FCC Part15.209 9k-30M		Humidity(%): 47%RH
M/N.:	W203	Power Rating:	AC 120 V/60 Hz
Mode:	Wireless Charge	Test Engineer:	Ken
Note:			

No.	Frequency (MHz)	Reading (dBuV)	Correct (dB/m)	Result (dBuV/m)	Limit (dBuV/m)	Margin (dB)	Remark
1	0.327100	69.83	7.05	76.88	97.45	-20.57	peak
2	0.327100	57.48	7.05	64.53	97.45	-32.92	AVG
3	1.463700	63.15	-6.33	56.82	64.35	-7.53	QP
4	2.269700	65.46	-9.65	55.81	69.50	-13.69	peak
5	2.866100	67.15	-11.40	55.75	69.50	-13.75	peak
6	3.463200	70.20	-12.97	57.23	69.50	-12.27	peak
7	4.478700	72.75	-15.06	57.69	69.50	-11.81	peak

30MHz-1GHz:

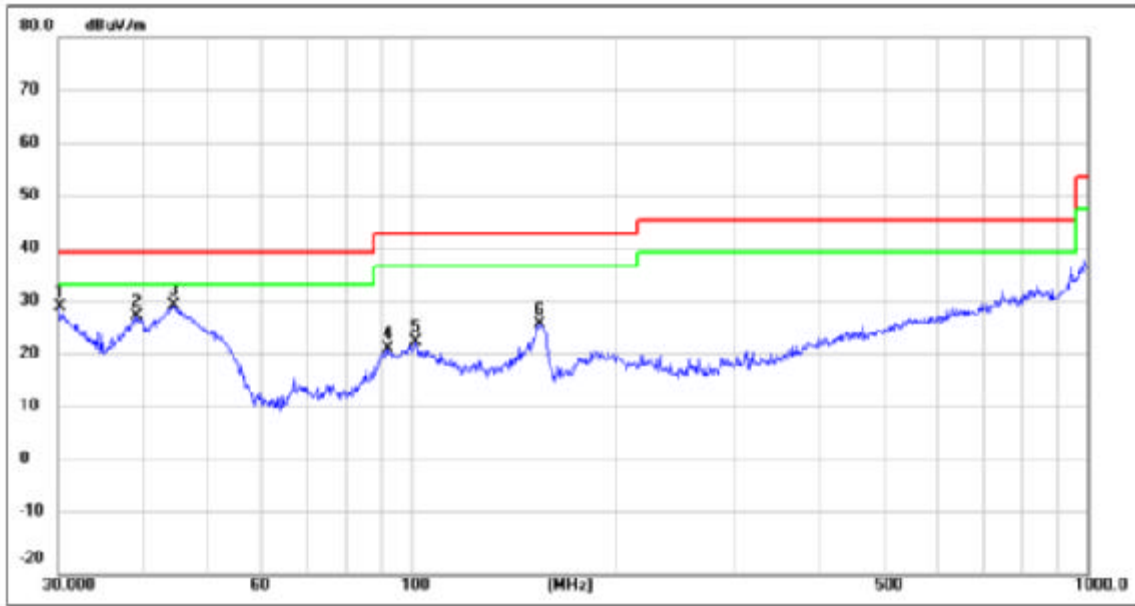

Site:		Antenna: Vertical	Temperature(C): 24(C)
Limit:	FCC Class 15C 3M Radiation(QP)		Humidity(%): 55%

M/N.:	W203	Power Rating:	AC 120 V/60 Hz
Mode:	Wireless Charge	Test Engineer:	Ken
Note:			

No.	Frequency (MHz)	Reading (dBuV)	Factor (dB/m)	Level (dBuV/m)	Limit (dBuV/m)	Margin (dB)	Det.
1	30.1054	27.71	2.24	29.95	40.00	-10.05	peak
2	39.1616	31.28	-3.20	28.08	40.00	-11.92	peak
3 *	44.5868	35.00	-4.82	30.18	40.00	-9.82	peak
4	92.1388	30.86	-8.65	22.21	43.50	-21.29	peak
5	101.6443	31.24	-8.01	23.23	43.50	-20.27	peak
6	154.2786	35.19	-8.47	26.72	43.50	-16.78	peak

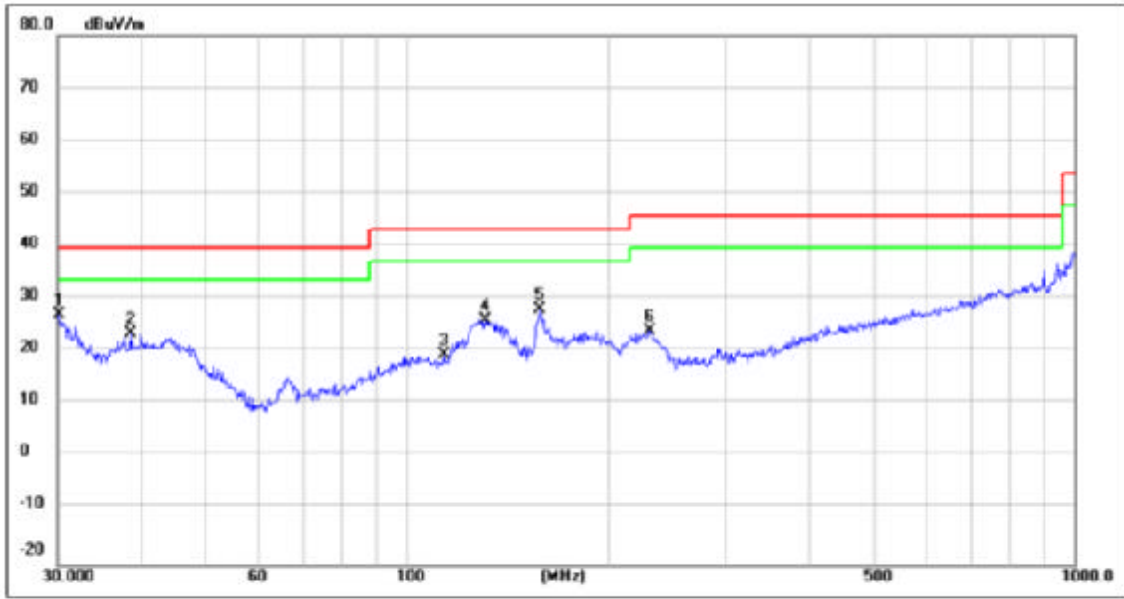

Site:	Antenna:Horizontal	Temperature(C):24(C)
Limit: FCC Class 15C 3M Radiation(QP)		Humidity(%):55%
M/N.: W203	Power Rating: AC 120 V/60 Hz	
Mode: Wireless Charge	Test Engineer: Ken	
Note:		

No.	Frequency (MHz)	Reading (dBuV)	Factor (dB/m)	Level (dBuV/m)	Limit (dBuV/m)	Margin (dB)	Det.
1 *	30.1054	25.06	2.24	27.30	40.00	-12.70	peak
2	38.6160	27.06	-3.31	23.75	40.00	-16.25	peak
3	113.7143	28.66	-8.81	19.85	43.50	-23.65	peak
4	131.2965	34.54	-8.19	26.35	43.50	-17.15	peak
5	158.1123	36.81	-8.47	28.34	43.50	-15.16	peak
6	230.9068	33.00	-8.54	24.46	46.00	-21.54	peak

7. ANTENNA APPLICATION

7.1. Antenna Requirement

Standard	Requirement
FCC CRF Part 15.203	<p>An intentional radiator shall be designed to ensure that no antenna other than that furnished by the responsible party shall be used with the device. The use of a permanently attached antenna or of an antenna that uses a unique coupling to the intentional radiator shall be considered sufficient to comply with the provisions of this section. The manufacturer may design the unit so that a broken antenna can be replaced by the user, but the use of a standard antenna jack or electrical connector is prohibited. This requirement does not apply to carrier current devices or to devices operated under the provisions of §15.211, §15.213, §15.217, §15.219, or §15.221. Further, this requirement does not apply to intentional radiators that must be professionally installed, such as perimeter protection systems and some field disturbance sensors, or to other intentional radiators which, in accordance with §15.31(d), must be measured at the installation site. However, the installer shall be responsible for ensuring that the proper antenna is employed so that the limits in this part are not exceeded.</p>

For intentional device, according to FCC 47 CFR Section 15.203, an intentional radiator shall be designed to ensure that no antenna other than that furnished by the responsible party shall be used with the device.

7.2. Result

PASS.

The EUT has 1 antennas: an Inductive Loop Antenna, antenna has a gain of 0 dBi;

- Note:
- Antenna use a permanently attached antenna which is not replaceable.
 - Not using a standard antenna jack or electrical connector for antenna replacement
 - The antenna has to be professionally installed (please provide method of installation)

which in accordance to section 15.203, please refer to the internal photos.

-----The end-----