

Acknowledgement

ROHS

客户名称 (CUSTOMER): SHENZHEN GTL TECHNOLOGY CO., LTD

客户料号 (CUSTOMER P/N):

品名 (DESCRIPTION):

DATE:2022-6-9

规格 (SPECIFICATION): Watch coil soft magnetic

REV. NO. :A0

Hongrishengwei technology Acknowledgement, signature and seal

Department	Appoval/Date	Reviewed by/Date	Approval/Date	(Official seal of the company)
QC	Dong xiaohong 2022-6-9	Lv Hui2022-6-9	Wei hanmao 2022-6-9	
QC	He weihua 2022-6-9	Wei lihong 2022-6-9	Wei lihong 2022-6-9	

Remark:

GTL Technolgoy Acknowledgement, signature and seal

Department	Appoval/Date	Reviewed by/Date	Approval/Date	(Official seal of the
Development Engineering				
Purchase				
QC				

Remark :

Shenzhen Hongrishengwei Technology Co., Ltd

HRSW ELECTRONICS CO.,LTD

ADD: Floor 2, Building 1, No. 48 Huanguan Middle Road,
Guanlan, Longhua New District, Shenzhen

TEL: +86-755-23461055 FAX: +86-0755-28015170

SPECIFICATION FOR APPROVAL

1. MECHANICAL DIMENSION (UNIT:mm)

2. SCHEMATICS:

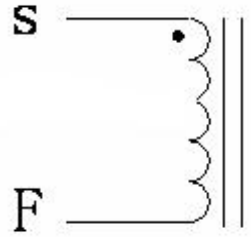
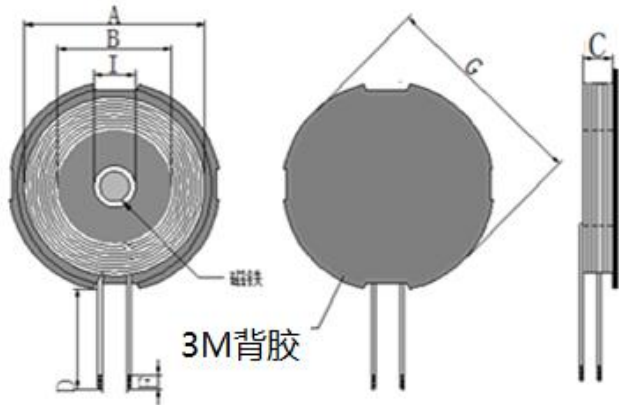

Max coil gain: 0dBi

A	B	C	D	F	G	I			
20±2	15±1	2.8±0.5	30±2	4±2	25REF	7.8±0.5			

3. WINDING:

STEP	START-FINISH	WIRE TYPE	TURNS	TAPE	REMARK
N1	S-F	0.08*24mm 2UEW	12TS (Ref)		

4. ELECTRICAL SPECIFICATION:

ITEM	L	DCR	IDC	Q值	HI-POT
TEST	S-F	S-F	S-F		
CON	100KHz, 0.25V	AT 25°C	AT 25°C		
SPEC	8.1uH±10%	40mΩ (Max)	3A		

5. BILF OF MATERIAL:

NO.	ITEM	MATERIAL SPECIFICATION	MANUFACTURER	SGS NO.
1	Magnetic core	UG25 Soft magnetism	NANJINGJINNINGCO,LTD	
2	Magnet	N52 7.5*2.45/3200 gose	NANJINGJINNINGCO,LTD	
3	Copper wire	0.08mm*24 2UEW	TAIYI CO.,LTD	
4	Gum backing	25 Single side adhesive	HONGBAOJEICO,LTD	
5	Solder Bar	Solder Bar	QIANDAO CO.,LTD	
6	Glue	9999	CUDAK CO.,LTD	

Shenzhen Hongrishengwei Technology Co.

PART NO

TITLE

Watch coil soft magnetic

DRAWN BY

CHECKED BY

APPROVED BY

Xie chao

He weihua

Wei lihong

SPECIFICATION FOR APPROVAL

6. SAMPLE TEST DATA

6.1 DIMENSION TEST (UNIT:mm)

TEST ITEM	A	B	C	D	F	G	I		
	20±2	15±1	2.8±0.5	30±2	4±2	25REF	7.8±0.5		
1	21.5	14.5	2.85	31	2.45	25.10	7.81		
2	20.6	14.68	2.86	30	3.80	23.77	7.86		
3	20.8	14.71	2.79	31.5	3.60	24.05	7.82		
4	21.3	14.38	2.89	32	2.70	25.06	7.89		
5	21.5	14.62	2.91	30.21	3.60	25.08	7.87		
MAX	21.50	14.71	2.91	32.00	3.80	25.10	7.89		
MIN	20.60	14.38	2.79	30.00	2.45	23.77	7.81		
AVERAGE	21.11	14.57	2.86	30.96	3.20	24.61	7.85		

6.2 ELECTRICAL TEST

TEST ITEM	L		DCR	IDC		Q	HI-POT		
	S-F		S-F						
TEST COND	100KHz/0.25v		AT 25°C						
SPEC	8.1uH±10%		40mΩ (Max)						
1	8.10		21.00						
2	7.96		20.00						
3	8.06		21.50						
4	8.04		20.30						
5	8.09		20.40						
6									
MAX	8.10		21.50						
MIN	7.96		20.00						
AVERAGE	8.05		20.75						

Shenzhen Hongrishengwei Technology Co., Ltd				PART NO				
				TITLE		Watch coil soft magnetic		
DRAWN BY			CHECKED BY			APPROVED BY		
Xiechao			He weihua			Wei lihong		