

Acknowledgment Letter

SPECIFICATION FOR APPROVAL

CUSTOMER: Jinzhizhuo Technology Co., Lt

CUSTOMER P/N:

DESCRIPTION : DATE: 2024/7/5

SPECIFICATION : G43.5 slotting+12 circles of adhesive backing 6.3UH 15MM REV.NO.:A0

Hongri Shengwei Technology acknowledges, signs and seals

department	confirm	to examine	ratify	Stamped with the company seal
quality	Dong Wanhong	Lv Hui	Wei Hanman	
engineering	He Weihua	Wei Lihong	Wei Lihong	

notes:

Jin Zhizhuo Technology acknowledges, signs, and stamps

department	Confirmation/Date	Review/Date	Approved/date	Stamped with the company seal
development engineering				
procurement				
quality				

notes:

Shenzhen Hongrishiengwei Technology Co., Ltd

DD: 2nd Floor, Building 1, No. 48 Guanlan Huanguan Middle Road, Longhua New District

TEL: 15112254520/13682412162

page: 1/2

SPECIFICATION FOR APPROVAL

1. MECHANICAL DIMENSION (UNIT:mm)

2. SCHEMATICS:

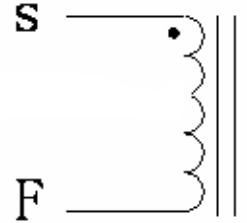
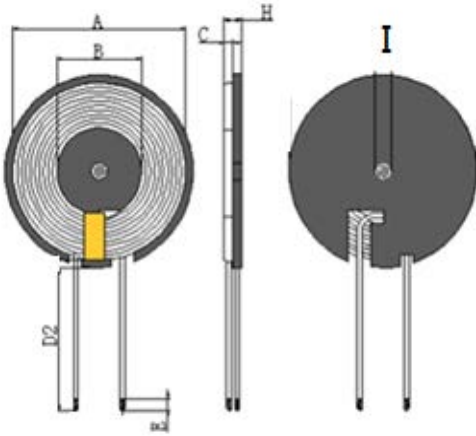

1. Coil magnetic sheet, magnetic sheet size
43.5 ± 0.3mm, with a thickness of 0.8 ± 0.06mm

Open an L cable slot.

2. Coil outlet position

Wrap adhesive paper 1-2Ts;

A	B	C	D2	E	H	I			I
43.5±0.03	13.5±0.2	0.8±0.06	15±2	3±2	2.8MAX	5+0.1			

3. WINDING:

STEP	START-FINISH	WIRE TYPE	TURNS	TAPE	REMARK
N1	S-F	silk covered wire 0.08*105mm 2UEW	12TS (Ref)		

4. ELECTRICAL SPECIFICATION:

ITEM	L	DCR	L	HI-POT
TEST	Coils with magnetic plates	S-F	Individual coils	
CON	100KHz, 0.25V	AT 25°C	100KHz, 0.25V	
SPEC	6.3uH±8%	60mΩ Max	3.8uH±8%	

5. BILF OF MATERIAL:

NO.	ITEM	MATERIAL SPECIFICATION	MANUFACTURER	SGS NO.
1	0.08 * 105 strands of silk wire	Acetone silk wrapped wire 0.08 * 105 strands	NANJINGJINNINGCO,LTD	
2	Solder Bar	Solder Bar	QIAODO	
3	magnetic sheet	43.5*0.8Manganese zinc hard magnetic sheets with L slots	TAIYI CO.,LTD	
4	glue	Yellow gum 9999	LIANCHENG CO.,LTD	
5	High temperature adhesive paper	7mmWide high-temperature adhesive paper	CUDAK CO.,LTD	
6	Adhesive backing	41.8*0.1/3M	CUDAK CO.,LTD	

HRSW ELECTRONICS CO.,LTD	PART NO	
	TITLE	G43.5 slotting+adhesive backing
DRAWN BY	CHECKED BY	APPROVED BY
He Weihua	Wei Lihong	Wei Lihong