



# FCC TEST REPORT

## FCC ID:2A4TT-CW370

**Report Number**..... : **ZKT-2205113073E**

Date of Test..... May. 11, 2022 to May. 22, 2022

Date of issue..... : May. 22, 2022

Total number of pages..... 23

Test Result ..... : PASS

**Testing Laboratory**..... : **Shenzhen ZKT Technology Co., Ltd.**

Address ..... : 1/F, No. 101, Building B, No. 6, Tangwei Community Industrial Avenue, Fuhai Street, Bao'an District, Shenzhen, China

**Applicant's name** ..... : **SHEN ZHEN GTL TECHNOLOGY CO.,LTD**

Address ..... : SHENZHEN BAOAN HANGCHENGJIEDAO  
HENGFENGGONGYECHNG B11,6L SHEN ZHEN China

**Manufacturer's name** ..... : **SHEN ZHEN GTL TECHNOLOGY CO.,LTD**

Address ..... : SHENZHEN BAOAN HANGCHENGJIEDAO  
HENGFENGGONGYECHNG B11,6L SHEN ZHEN China

**Test specification:**

Standard..... : FCC CFR Title 47 Part 15 Subpart C

Test procedure..... : /

Non-standard test method ..... : N/A

**Test Report Form No**..... : TRF-EL-107\_V0

**Test Report Form(s) Originator**..... : ZKT Testing

**Master TRF** ..... : Dated: 2020-01-06

This device described above has been tested by ZKT, and the test results show that the equipment under test (EUT) is in compliance with the FCC requirements. And it is applicable only to the tested sample identified in the report.

This report shall not be reproduced except in full, without the written approval of ZKT, this document may be altered or revised by ZKT, personal only, and shall be noted in the revision of the document.

**Product name**..... : **3 in 1 Charging Station**

Trademark ..... : N/A

Model/Type reference..... : CW370

Ratings..... : Input: DC 5V 2A  
Wireless Output : 3W



**Testing procedure and testing location:**

**Testing Laboratory**.....: **Shenzhen ZKT Technology Co., Ltd.**

**Address**.....: 1/F, No. 101, Building B, No. 6, Tangwei Community Industrial Avenue, Fuhai Street, Bao'an District, Shenzhen, China

**Tested by (name + signature)**.....: Jim Liu

**Reviewer (name + signature)**.....: Tom Zou

**Approved (name + signature)**.....: Lake Xie





## TABLE OF CONTENTS

<b>1. VERSION</b>	<b>4</b>
<b>2. TEST SUMMARY</b>	<b>5</b>
2.1 TEST FACILITY	6
2.2 MEASUREMENT UNCERTAINTY	6
<b>3. GENERAL INFORMATION</b>	<b>7</b>
3.1 GENERAL DESCRIPTION OF EUT	7
3.2 Test mode	7
3.3 Block Diagram of EUT Configuration	7
3.4 Test Conditions	8
3.5 Description Of Support Units (Conducted Mode)	8
3.6 EQUIPMENTS LIST FOR ALL TEST ITEMS	8
<b>4. CONDUCTED EMISSION TEST</b>	<b>10</b>
4.1 CONDUCTED EMISSION MEASUREMENT	10
4.1.1 POWER LINE CONDUCTED EMISSION Limits	10
4.1.2 TEST PROCEDURE	10
4.1.3 DEVIATION FROM TEST STANDARD	11
4.1.4 TEST SETUP	11
4.1.5 EUT OPERATING CONDITIONS	11
4.1.6 Test Result	12
<b>5. RADIATED EMISSION MEASUREMENT</b>	<b>14</b>
5.1 Radiated Emission Limits	15
5.2 Anechoic Chamber Test Setup Diagram	16
5.3 Test Procedure	16
5.4 DEVIATION FROM TEST STANDARD	16
5.5 Test Result	17
<b>6. BANDWIDTH TEST</b>	<b>20</b>
<b>7. TEST SETUP PHOTO</b>	<b>23</b>
<b>8. EUT CONSTRUCTIONAL DETAILS</b>	<b>23</b>



**1. VERSION**

Report No.	Version	Description	Approved
ZKT-2205113073E	Rev.01	Initial issue of report	May. 22, 2022



## 2. TEST SUMMARY

Test Item	Section in CFR 47	Result
Antenna requirement	15.203	Pass
AC Power Line Conducted Emission	15.207	Pass
Spurious Emission	15.209(a)(f)	Pass
20dB Bandwidth	15.215	Pass

NOTE:

(1) "N/A" denotes test is not applicable in this Test Report



## 2.1 TEST FACILITY

Shenzhen ZKT Technology Co., Ltd.  
Add. : 1/F, No. 101, Building B, No. 6, Tangwei Community Industrial Avenue, Fuhai Street,  
Bao'an District, Shenzhen, China

FCC Test Firm Registration Number: 692225  
Designation Number: CN1299  
IC Registered No.: 27033

## 2.2 MEASUREMENT UNCERTAINTY

The reported uncertainty of measurement  $y \pm U$ , where expanded uncertainty  $U$  is based on a standard uncertainty multiplied by a coverage factor of  $k=2$ , providing a level of confidence of approximately 95 %.

No.	Item	Uncertainty
1	3m chamber Radiated spurious emission(9KHz-30MHz)	U=4.5dB
2	3m chamber Radiated spurious emission(30MHz-1GHz)	U=4.8dB
3	3m chamber Radiated spurious emission(1GHz-6GHz)	U=4.9dB
4	3m chamber Radiated spurious emission(6GHz-40GHz)	U=5.0dB
5	Conducted disturbance	U=3.2dB
6	RF Band Edge	U=1.68dB
7	RF power conducted	U=1.86dB
8	RF conducted Spurious Emission	U=2.2dB
9	RF Occupied Bandwidth	U=1.8dB
10	RF Power Spectral Density	U=1.75dB
11	humidity uncertainty	U=5.3%
12	Temperature uncertainty	U=0.59°C



### 3. GENERAL INFORMATION

#### 3.1 GENERAL DESCRIPTION OF EUT

Product Name:	3 in 1 Charging Station
Model No.:	CW370
Model Difference:	N/A
Serial No.:	N/A
Hardware version:	H1.0
Software version:	S1.0
Operation Frequency:	115kHz ~ 205KHz
Modulation type:	MSK
Antenna Type:	Inductive loop coil Antenna
Antenna gain:	0dBi
Power supply:	Input: DC 5V 2A Wireless Output : 3W
Test Description:	Phone Battery>98%, =50%and <1% are tested, and the worst is <1%.

#### 3.2 Test mode

Test Modes:		
Mode 1	AC/DC Adapter (5V/2A) + EUT + I Watch (3W) coil	Record

#### 3.3 Block Diagram of EUT Configuration

##### Conducted Emission

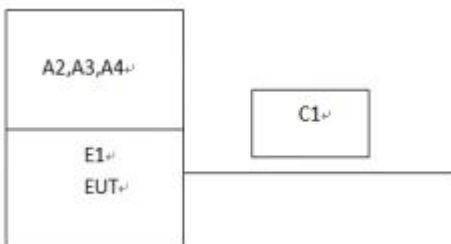

##### Radiated Emission

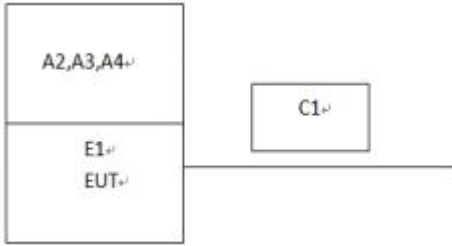

### 3.4 Test Conditions

Temperature: 23~26°C

Relative Humidity: 54~63 %

### 3.5 Description Of Support Units (Conducted Mode)

The EUT has been tested as an independent unit together with other necessary accessories or support units. The following support units or accessories were used to form a representative test configuration during the tests.

Item	Equipment	Mfr/Brand	Model/Type No.	Series No.	Note
E1	3 in 1 Charging Station	N/A	CW370	N/A	EUT
A-1	AC Adapter	HuaWei	ZKT-01	N/A	Auxiliary
A-2	I Watch	Apple	ZKT-02	N/A	Auxiliary
A-3	Phone	XiaoMi	ZKT-03	N/A	Auxiliary
A-4	TWS	XiaoMi	ZKT-04	N/A	Auxiliary

Item	Shielded Type	Ferrite Core	Length	Note
C1	NO	NO	1.0M	DC cable unshielded

Note:

- (1) The support equipment was authorized by Declaration of Confirmation.
- (2) For detachable type I/O cable should be specified the length in cm in 『Length』 column.
- (3) “YES” is means “shielded” “with core”; “NO” is means “unshielded” “without core”.

### 3.6 EQUIPMENTS LIST FOR ALL TEST ITEMS

Radiation Test equipment





Item	Equipment	Manufacturer	Type No.	Serial No.	Last calibration	Calibrated until
1	Spectrum Analyzer (9kHz-26.5GHz)	KEYSIGHT	9020A	MY45109572	Sep. 22, 2021	Sep. 21, 2022
2	Spectrum Analyzer (1GHz-40GHz)	Agilent	E4446A	100363	Sep. 22, 2021	Sep. 21, 2022
3	Test Receiver (9kHz-7GHz)	R&S	ESCI7	101169	Sep. 22, 2021	Sep. 21, 2022
4	Bilog Antenna (30MHz-1400MHz)	Schwarzbeck	VULB9168	00877	Sep. 22, 2021	Sep. 21, 2022
5	Horn Antenna (1GHz-18GHz)	SCHWARZBEC K	BBHA9120D	1541	Sep. 22, 2021	Sep. 21, 2022
6	Horn Antenna (18GHz-40GHz)	A.H. System	SAS-574	588	Sep. 22, 2021	Sep. 21, 2022
7	Amplifier (30-1000MHz)	EM Electronics	EM330 Amplifier	N/A	Sep. 22, 2021	Sep. 21, 2022
8	Amplifier (1GHz-40GHz)	全聚达	DLE-161	097	Sep. 22, 2021	Sep. 21, 2022
9	Loop Antenna (9kHz-30MHz)	SCHWARZBEC K	FMZB1519B	014	Sep. 22, 2021	Sep. 21, 2022
10	RF cables1 (9kHz-30MHz)	N/A	9kHz-30MHz	N/A	Sep. 22, 2021	Sep. 21, 2022
11	RF cables2 (30MHz-1GHz)	N/A	30MHz-1GHz	N/A	Sep. 22, 2021	Sep. 21, 2022
12	RF cables3 (1GHz-40GHz)	N/A	1GHz-40GHz	N/A	Sep. 22, 2021	Sep. 21, 2022
13	CMW500 Test	R&S	CMW500	106504	Sep. 22, 2021	Sep. 21, 2022
14	ESG Signal Generator	Agilent	E4421B	GB40051203	Sep. 22, 2021	Sep. 21, 2022
15	Signal Generator	Agilent	N5182A	MY47420215	Sep. 22, 2021	Sep. 21, 2022
16	D.C. Power Supply	LongWei	TPR-6405D	\	\	\
17	MWRF Power Meter Test system	MW	MW100-RPCB	\	Sep. 22, 2021	Sep. 21, 2022
17	EMC Software	Frad	EZ-EMC	Ver.EMC-CON 3A1.1	\	\
18	RF Software	MW	MTS8310	V2.0.0.0	\	\
19	Turntable	MF	MF-7802BS	\	\	\
20	Antenna tower	MF	MF-7802BS	\	\	\



Conduction Test equipment

Item	Kind of Equipment	Manufacturer	Type No.	Serial No.	Last calibration	Calibrated until
1	LISN	R&S	ENV216	N/A	Sep. 22, 2021	Sep. 21, 2022
2	LISN	CYBERTEK	EM5040A	N/A	Sep. 22, 2021	Sep. 21, 2022
3	Test Cable	N/A	C01	N/A	Sep. 22, 2021	Sep. 21, 2022
4	Test Cable	N/A	C02	N/A	Sep. 22, 2021	Sep. 21, 2022
5	EMI Test Receiver	R&S	ESCI3	101421	Sep. 22, 2021	Sep. 21, 2022
6	Triple-Loop Antenna	LAPLACE	RF300	9194	Sep. 22, 2021	Sep. 21, 2022
7	Absorbing Clamp	DZ	ZN23201	N/A	Sep. 22, 2021	Sep. 21, 2022
8	EMC Software	Frad	EZ-EMC	Ver.EMC-CO N 3A1.1	\	\

**4. CONDUCTED EMISSION TEST**

4.1 CONDUCTED EMISSION MEASUREMENT

Test Requirement:	FCC ParCW3705 C Section 15.207
Test Method:	ANSI C63.10:2013
Test Frequency Range:	150KHz to 30MHz
Receiver setup:	RBW=9KHz, VBW=30KHz, Sweep time=auto

4.1.1 POWER LINE CONDUCTED EMISSION Limits

FREQUENCY (MHz)	Limit (dBuV)		Standard
	Quas-peak	Average	
0.15 -0.5	66 - 56 *	56 - 46 *	FCC
0.50 -5.0	56.00	46.00	FCC
5.0 -30.0	60.00	50.00	FCC

Note:

(1) \*Decreases with the logarithm of the frequency.

4.1.2 TEST PROCEDURE

- a. The EUT was placed 0.8 meters from the horizontal ground plane with EUT being connected to the power mains through a line impedance stabilization network (LISN). All other support equipments powered from additional LISN(s). The LISN provide 50 Ohm/ 50uH of coupling impedance for the measuring instrument.
- b. Interconnecting cables that hang closer than 40 cm to the ground plane shall be folded back and forth in the center forming a bundle 30 to 40 cm long.



- c. I/O cables that are not connected to a peripheral shall be bundled in the center. The end of the cable may be terminated, if required, using the correct terminating impedance. The overall length shall not exceed 1 m.
- d. LISN at least 80 cm from nearest part of EUT chassis.
- e. For the actual test configuration, please refer to the related Item –EUT Test Photos.

#### 4.1.3 DEVIATION FROM TEST STANDARD

No deviation

#### 4.1.4 TEST SETUP

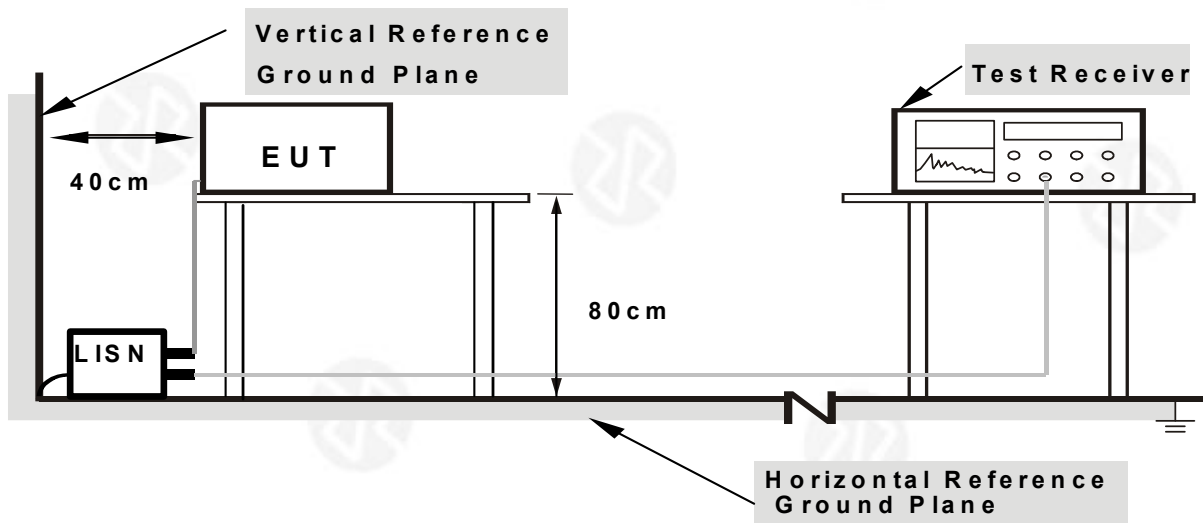

**Note: 1. Support units were connected to second LISN.**

**2. Both of LISNs (AMN) are 80 cm from EUT and at least 80 cm from other units and other metal planes**

#### 4.1.5 EUT OPERATING CONDITIONS

The EUT was configured for testing in a typical fashion (as a customer would normally use it). The EUT has been programmed to continuously transmit during test. This operating condition was tested and used to collect the included data.



#### 4.1.6 Test Result

Temperature:	26°C	Relative Humidity:	54%
Pressure:	101kPa	Phase :	L
Test Voltage :	AC 120V		

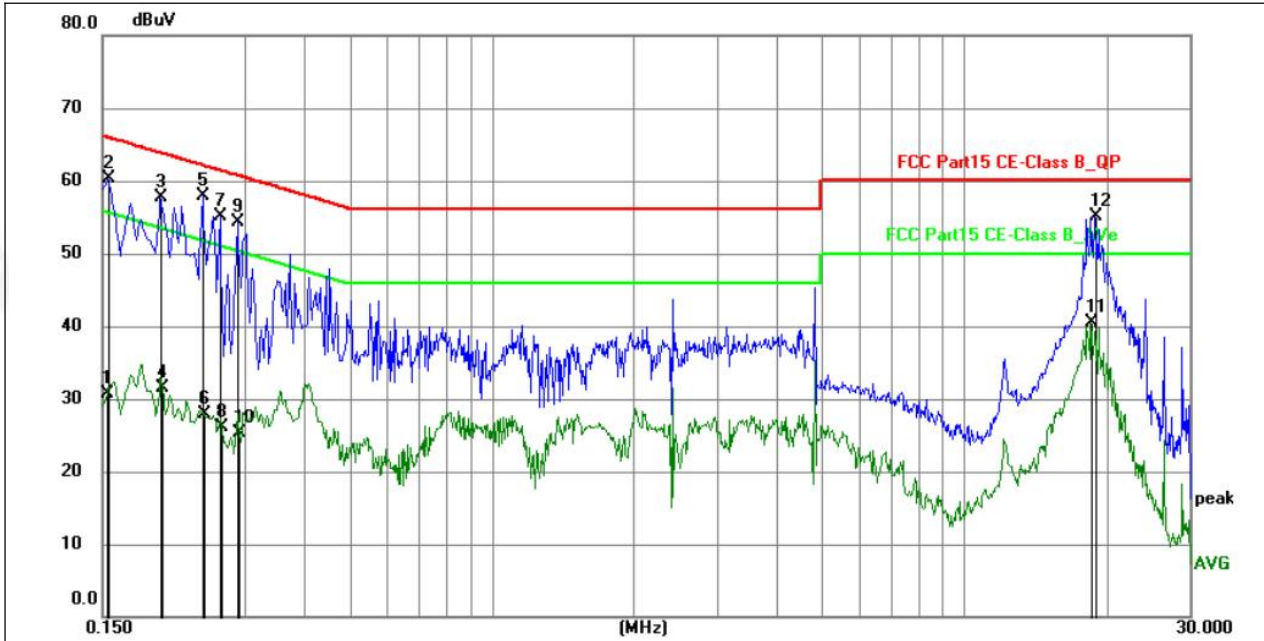

No.	Frequency (MHz)	Reading (dBuV)	Factor (dB)	Level (dBuV)	Limit (dBuV)	Margin (dB)	Detector	P/F	Remark
1	0.1532	17.69	12.94	30.63	55.82	-25.19	AVG	P	
2	0.1544	47.41	12.91	60.32	65.76	-5.44	QP	P	
3	0.1995	45.71	11.93	57.64	63.63	-5.99	QP	P	
4	0.2007	19.56	11.92	31.48	53.58	-22.10	AVG	P	
5	0.2445	46.27	11.71	57.98	61.94	-3.96	QP	P	
6	0.2468	16.11	11.70	27.81	51.86	-24.05	AVG	P	
7	0.2670	43.43	11.61	55.04	61.21	-6.17	QP	P	
8	0.2686	14.47	11.60	26.07	51.16	-25.09	AVG	P	
9	0.2895	42.75	11.51	54.26	60.54	-6.28	QP	P	
10	0.2924	13.89	11.50	25.39	50.46	-25.07	AVG	P	
11	18.6044	30.75	9.66	40.41	50.00	-9.59	AVG	P	
12	18.9240	45.39	9.71	55.10	60.00	-4.90	QP	P	

Notes:

- 1.An initial pre-scan was performed on the line and neutral lines with peak detector.
- 2.Quasi-Peak and Average measurement were performed at the frequencies with maximized peak emission.
- 3.Measurement Level = Reading level + Correct Factor

Temperature:	26°C	Relative Humidity:	54%
Pressure:	101kPa	Phase :	N
Test Voltage :	AC 120V		

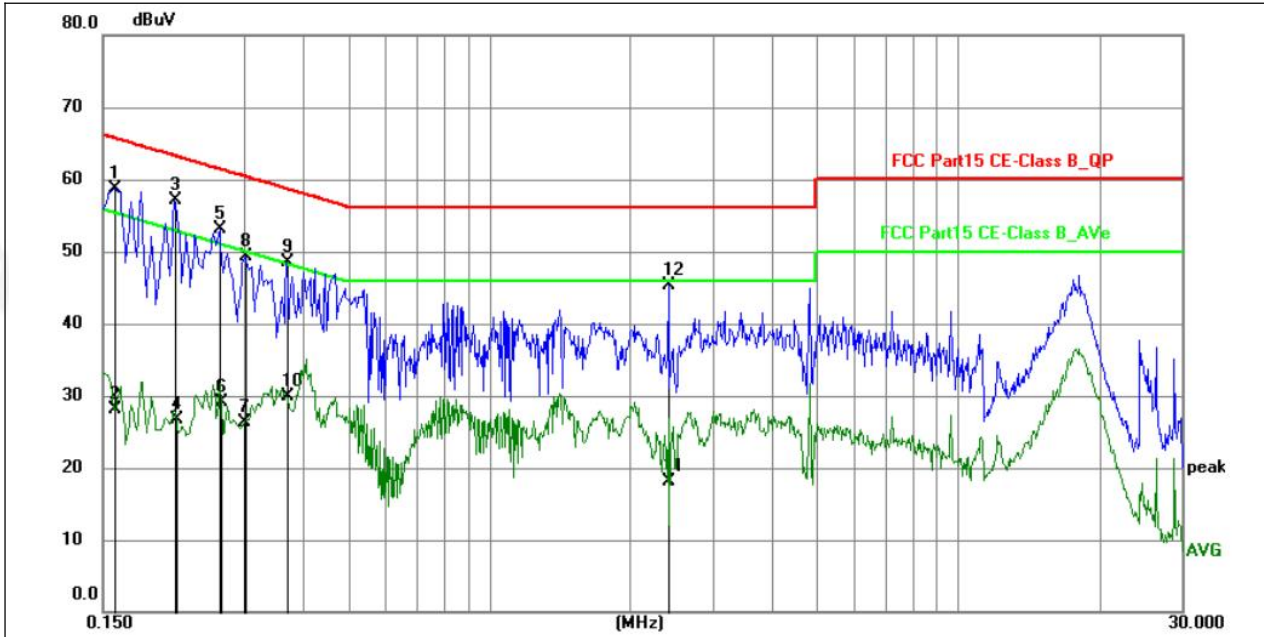

No.	Frequency (MHz)	Reading (dBuV)	Factor (dB)	Level (dBuV)	Limit (dBuV)	Margin (dB)	Detector	P/F	Remark
1	0.1590	45.90	12.81	58.71	65.52	-6.81	QP	P	
2	0.1590	15.35	12.81	28.16	55.52	-27.36	AVG	P	
3	0.2130	45.20	11.86	57.06	63.09	-6.03	QP	P	
4	0.2150	14.78	11.85	26.63	53.01	-26.38	AVG	P	
5	0.2670	41.47	11.61	53.08	61.21	-8.13	QP	P	
6	0.2686	17.52	11.60	29.12	51.16	-22.04	AVG	P	
7	0.3002	14.80	11.46	26.26	50.24	-23.98	AVG	P	
8	0.3030	37.82	11.45	49.27	60.16	-10.89	QP	P	
9	0.3704	37.44	11.13	48.57	58.49	-9.92	QP	P	
10	0.3704	18.86	11.13	29.99	48.49	-18.50	AVG	P	
11	2.4044	8.03	10.09	18.12	46.00	-27.88	AVG	P	
12	2.4134	35.14	10.09	45.23	56.00	-10.77	QP	P	

Notes:

1. An initial pre-scan was performed on the line and neutral lines with peak detector.
2. Quasi-Peak and Average measurement were performed at the frequencies with maximized peak emission.
3. Measurement Level = Reading level + Correct Factor

5. RADIATED EMISSION MEASUREMENT

Test Requirement:	FCC ParCW3705 C Section 15.209
-------------------	--------------------------------



Test Method:	ANSI C63.10:2013				
Test Frequency Range:	9kHz to 1GHz				
Test site:	Measurement Distance: 3m				
Receiver setup:	Frequency	Detector	RBW	VBW	Value
	9KHz-150KHz	Quasi-peak	200Hz	600Hz	Quasi-peak
	150KHz-30MHz	Quasi-peak	9KHz	30KHz	Quasi-peak
	30MHz-1GHz	Quasi-peak	100KHz	300KHz	Quasi-peak
	Above 1GHz	Peak	1MHz	3MHz	Peak
Peak		1MHz	10Hz	Average	

### 5.1 Radiated Emission Limits

#### Limits for frequency below 30MHz

Frequency	Limit (uV/m)	Measurement Distance(m)	Remark
0.009-0.490	2400/F(kHz)	300	Quasi-peak Value
0.490-1.705	24000/F(kHz)	30	Quasi-peak Value
1.705-30	30	30	Quasi-peak Value

#### Limits for frequency Above 30MHz

Frequency	Limit (dBuV/m @3m)	Remark
30MHz-88MHz	40.00	Quasi-peak Value
88MHz-216MHz	43.50	Quasi-peak Value
216MHz-960MHz	46.00	Quasi-peak Value
960MHz-1GHz	54.00	Quasi-peak Value
Above 1GHz	54.00	Average Value
	74.00	Peak Value



## 5.2 Anechoic Chamber Test Setup Diagram

### (A) Radiated Emission Test-Up Frequency Below 30MHz

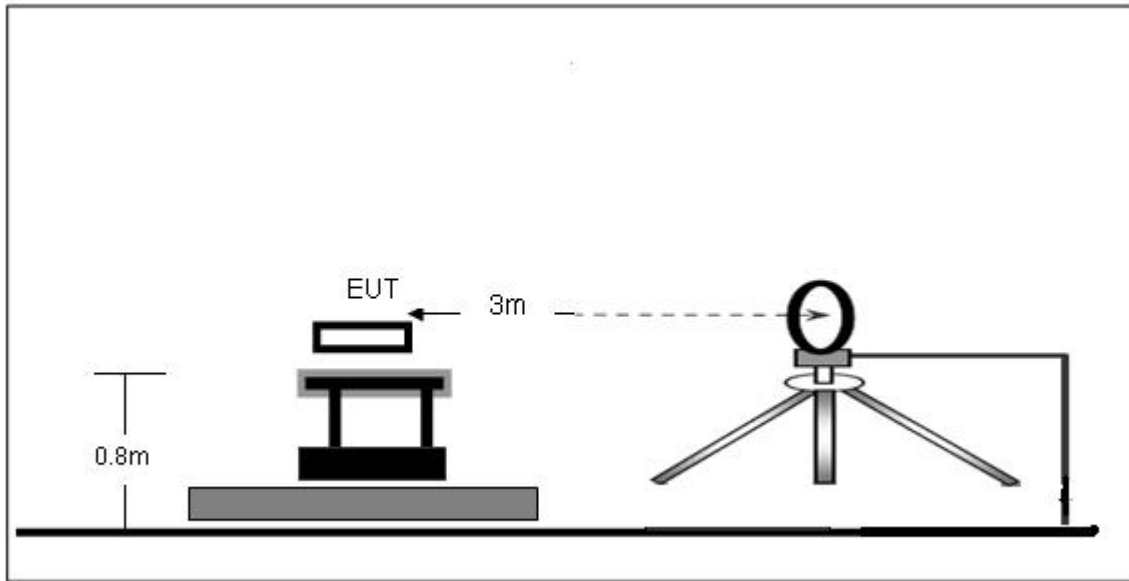

### (B) Radiated Emission Test-Up Frequency 30MHz~1GHz

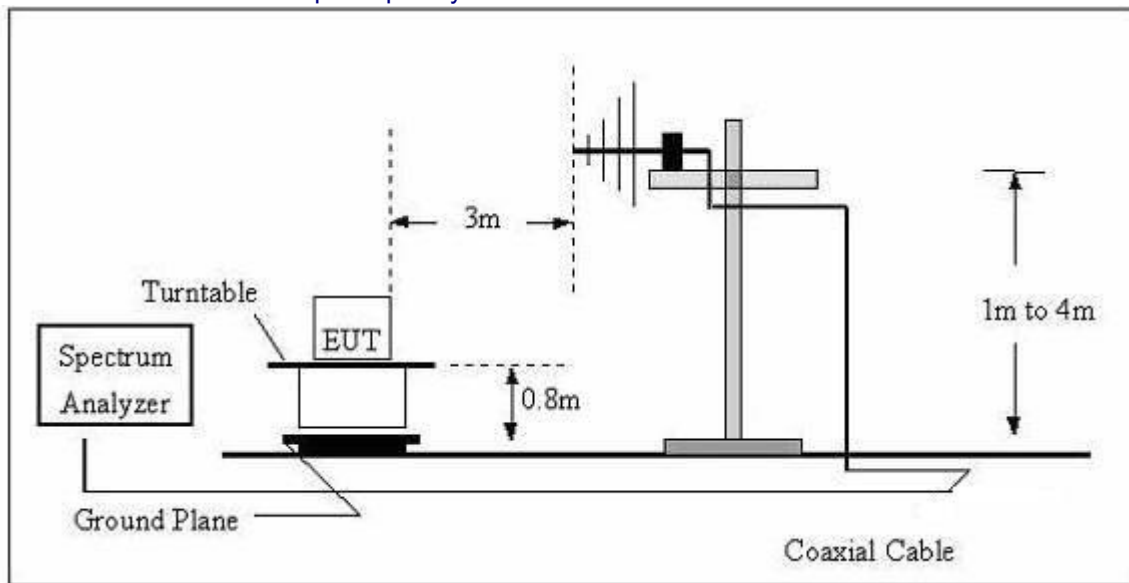

The radiated emission tests were performed in the 3 meters chamber test site, using the setup accordance with the ANSI C63.10-2013. The specification used was the FCC 15.209 and FCC 15.205 limits.

## 5.3 Test Procedure

The EUT is placed on a turn table which is 0.8 meter above ground. The turn table can rotate 360 degrees to determine the position of the maximum emission level. The EUT is set 3 meters away from the receiving antenna which is mounted on a antenna tower. The antenna can move up and down between 1 to 4 meters to find out the maximum emission level. Broadband antenna (calibrated by dipole antenna) are used as a receiving antenna. Both horizontal and vertical polarization of the antenna are set on measurement.

## 5.4 DEVIATION FROM TEST STANDARD

No deviation





### 5.5 Test Result

#### Measurement data:

Note: Limit dBuV/m @3m = Limit dBuV/m @300m+ 80

Limit dBuV/m @3m = Limit dBuV/m @30m + 40

9 kHz~30 MHz

Frequency	Meter Reading	Factor	Emission Level	Limits	Margin	Detector Type
(kHz)	(dBμV)	(dB)	(dBμV/m)	(dBμV/m)	(dB)	
24.86	40.18	20.25	60.43	139.62	-79.19	PK
24.86	31.52	20.17	51.69	119.74	-68.05	AV
56.75	50.24	20.35	70.59	132.57	-61.98	PK
56.75	43.32	20.34	63.66	112.63	-48.97	AV
121.63	68.78	20.75	89.53	125.95	-36.42	PK
121.63	38.77	20.54	59.31	105.98	-46.67	AV
685.34	32.25	20.84	53.09	70.79	-17.7	QP
965.76	36.88	21.16	58.04	67.94	-9.9	QP
1228.34	29.52	22.42	51.94	65.96	-14.02	QP

#### Note:

Pre-scan in the all of mode, the worst case in of was recorded.

Factor = antenna factor + cable loss – pre-amplifier.

Margin = Emission Level- Limit.



30MHz-1GHz

Temperature:	26°C	Relative Humidity:	54%
Pressure:	101 kPa	Polarization:	Horizontal
Test Voltage:	AC 120V/60Hz		

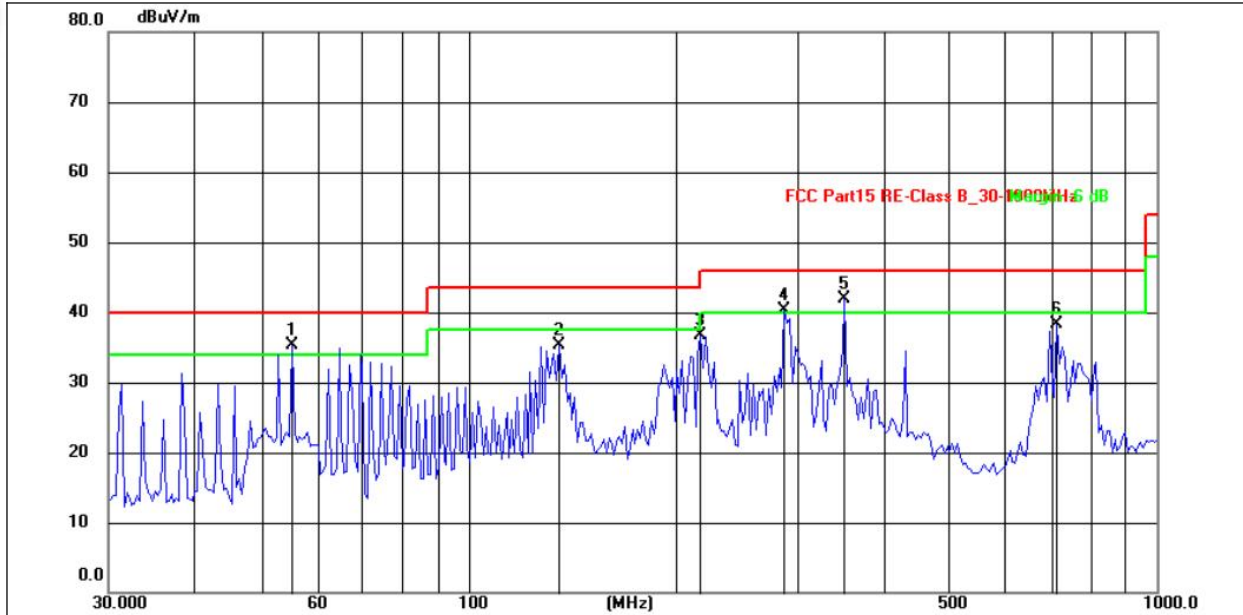

No.	Frequency (MHz)	Reading (dBuV)	Factor (dB/m)	Level (dBuV/m)	Limit (dBuV/m)	Margin (dB)	Detector
1	55.4147	49.41	-14.15	35.26	40.00	-4.74	QP
2	135.5061	52.95	-17.66	35.29	43.50	-8.21	QP
3	217.5442	55.77	-19.09	36.68	46.00	-9.32	QP
4	287.9904	57.68	-17.28	40.40	46.00	-5.60	QP
5	352.3249	60.71	-18.76	41.95	46.00	-4.05	QP
6	716.6820	46.95	-8.74	38.21	46.00	-7.79	QP



Temperature:	26°C	Relative Humidity:	54%
Pressure:	101kPa	Polarization:	Vertical
Test Voltage:	AC 120V/60Hz		

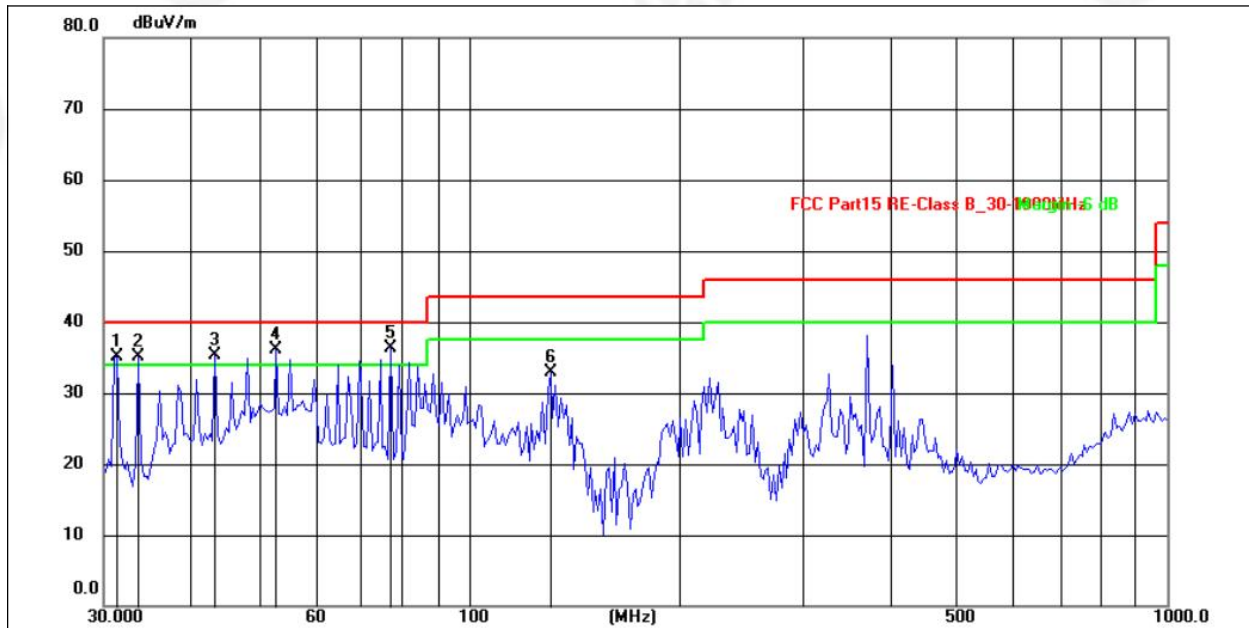

No.	Frequency (MHz)	Reading (dBuV)	Factor (dB/m)	Level (dBuV/m)	Limit (dBuV/m)	Margin (dB)	Detector
1	31.3442	53.36	-18.22	35.14	40.00	-4.86	QP
2	33.6212	52.96	-17.83	35.13	40.00	-4.87	QP
3	43.3534	52.31	-17.01	35.30	40.00	-4.70	QP
4	53.0382	53.74	-17.60	36.14	40.00	-3.86	QP
5	77.3210	57.44	-21.19	36.25	40.00	-3.75	QP
6	130.8369	54.38	-21.44	32.94	43.50	-10.56	QP

Remarks:

- 1.Final Level =Receiver Read level + Antenna Factor + Cable Loss – Preamplifier Factor
- 2.The emission levels of other frequencies are very lower than the limit and not show in test report.



## 6. BANDWIDTH TEST

1. Set RBW = 100Hz.
2. Set the video bandwidth (VBW)  $\geq 3 \times$  RBW.
3. Detector = Peak.
4. Trace mode = max hold.
5. Sweep = auto couple.
6. Allow the trace to stabilize.
7. Measure the maximum width of the emission that is constrained by the frequencies associated with the two outermost amplitude points (upper and lower frequencies) that are attenuated by 20 dB relative to the maximum level measured in the fundamental emission.

### TEST SETUP





Temperature:	26 °C	Relative Humidity:	54%
Pressure:	101kPa		

Frequency (KHz)	20dB bandwidth (Hz)	99% bandwidth (Hz)	Result
124.6	275	270	Pass





## 7. ANTENNA REQUIREMENT

Standard requirement:	FCC Part15 C Section 15.203
15.203 requirement:	An intentional radiator shall be designed to ensure that no antenna other than that furnished by the responsible party shall be used with the device. The use of a permanently attached antenna or of an antenna that uses a unique coupling to the intentional radiator, the manufacturer may design the unit so that a broken antenna can be replaced by the user, but the use of a standard antenna jack or electrical connector is prohibited.
EUT Antenna:	
	The antenna is Coil ANT, the best case gain of the antennas is 0dBi, reference to the appendix II for details



## 8. TEST SETUP PHOTO

Reference to the appendix I for details.

## 9. EUT CONSTRUCTIONAL DETAILS

Reference to the appendix II for details.

\*\*\*\*\* END OF REPORT \*\*\*\*\*