



FCC TEST REPORT

FCC ID: 2A4RD-SW-208

On Behalf of

Shenzhen Sunwin Technology Co.,Ltd

SPEAKER

Model No.: See Annex for details

Prepared for : Shenzhen Sunwin Technology Co.,Ltd
Address : No.202 B Bldg,No.13 Futang Rd, Tangxiayong Community, Yanluo
Street,Bao' an District, Shenzhen,China

Prepared By : Shenzhen Alpha Product Testing Co., Ltd.
Address : Building i, No.2, Lixin Road, Fuyong Street, Bao'an District, 518103,
Shenzhen, Guangdong, China

Report Number : A2202088-C01-R02
Date of Receipt : February 21, 2022
Date of Test : February 21, 2022-March 9, 2022
Date of Report : March 9, 2022
Version Number : V0

TABLE OF CONTENTS

Description	Page
1. Summary Of Standards And Results	6
1.1. Description of Standards and Results	6
2. General Information	7
2.1. Description of Device (EUT).....	7
2.2. Accessories of Device (EUT)	8
2.3. Tested Supporting System Details	8
2.4. Block Diagram of connection between EUT and simulators	8
2.5. Test Mode Description.....	8
2.6. Test Conditions	9
2.7. Test Facility	9
2.8. Measurement Uncertainty.....	9
2.9. Test Equipment List.....	10
3. Maximum Peak Output Power	11
3.1. Limit	11
3.2. Test Procedure	11
3.3. Test Setup.....	11
3.4. Test Result	11
4. Bandwidth.....	12
4.1. Limit	12
4.2. Test Procedure	12
4.3. Test Result	12
5. Carrier Frequency Separation.....	22
5.1. Limit	22
5.2. Test Procedure	22
5.3. Test Result	22
6. Number Of Hopping Channel.....	24
6.1. Limit	24
6.2. Test Procedure	24
6.3. Test Result	24
7. Dwell Time	26
7.1. Test limit	26
7.2. Test Procedure	26
7.3. Test Result	26
8. Radiated Emissions	43
8.1. Limit	43
8.2. Block Diagram of Test setup	44
8.3. Test Procedure	45
8.4. Test Result	45
9. Band Edge Compliance.....	56
9.1. Block Diagram of Test Setup.....	56

9.2. Limit	56
9.3. Test Procedure	56
9.4. Test Result	56
10. Power Line Conducted Emissions	66
10.1. Block Diagram of Test Setup.....	66
10.2. Limit	66
10.3. Test Procedure	66
10.4. Test Result	67
11. Antenna Requirements	70
11.1. Limit	70
11.2. Result	70
12. Test Setup Photo.....	71
12.1. Photos of Radiated emission.....	71
12.2. Photos of Conducted Emission test	72
13. EUT Photo.....	74
14. Annex.....	75

TEST REPORT DECLARATION

Applicant : Shenzhen Sunwin Technology Co.,Ltd
 Address : No.202 B Bldg,No.13 Futang Rd, Tangxiayong Community, Yanluo Street,Bao' an District, Shenzhen,China
 Manufacturer : Shenzhen Sunwin Technology Co.,Ltd
 Address : No.202 B Bldg,No.13 Futang Rd, Tangxiayong Community, Yanluo Street,Bao' an District, Shenzhen,China
 EUT Description : SPEAKER
 (A) Model No. : See Annex for details
 (B) Trademark : 

Measurement Standard Used:

FCC Rules and Regulations Part 15 Subpart C Section 15.247,

The device described above is tested by Shenzhen Alpha Product Testing Co., Ltd. to determine the maximum emission levels emanating from the device. The test results are contained in this test report and Shenzhen Alpha Product Testing Co., Ltd. is assumed of full responsibility for the accuracy and completeness of these tests.

After the test, our opinion is that EUT compliance with the requirement of the above standards.

This report applies to above tested sample only. This report shall not be reproduced in parts without written approval of Shenzhen Alpha Product Testing Co., Ltd.

Tested by (name + signature).....: Yannis Wen
 Project Engineer 

Approved by (name + signature).....: Simple Guan
 Project Manager 

Date of issue..... : March 9, 2022

Revision History

Revision	Issue Date	Revisions	Revised By
V0	March 9, 2022	Initial released Issue	Yannis Wen

1. Summary Of Standards And Results

1.1. Description of Standards and Results

The EUT have been tested according to the applicable standards as referenced below:

Test Item	Standards Paragraph	Result
Maximum Peak Output Power	FCC Part 15: 15.247(b)(1)	P
Bandwidth	FCC Part 15: 15.215	P
Carrier Frequency Separation	FCC Part 15: 15.247(a)(1)	P
Number Of Hopping Channel	FCC Part 15: 15.247(a)(1)	P
Dwell Time	FCC Part 15: 15.247(a)(1)	P
Radiated Emission	FCC Part 15: 15.209 FCC Part 15: 15.247(d)	P
Band Edge Compliance	FCC Part 15: 15.247(d)	P
Power Line Conducted Emissions	FCC Part 15: 15.207	P
Antenna requirement	FCC Part 15: 15.203	P
Note:	1. P is an abbreviation for Pass. 2. F is an abbreviation for Fail. 3. N/A is an abbreviation for Not Applicable.	

2. General Information

2.1. Description of Device (EUT)

Description/PMN	: SPEAKER
Model Number/HVIN(s)	: See Annex for details
Diff.	: There is no difference except for the appearance, shape and model name. So all the test were performed on the model SW-208.
Trademark	: 
Test Voltage	: AC 120V/60Hz
Radio Technology	: Bluetooth(BDR, EDR)
Operation frequency	: 2402-2480MHz
Channel No.	: 79 Channels for Bluetooth (BDR/EDR)
Channel Separation	: 1MHz for Bluetooth (BDR/EDR)
Modulation	: GFSK, $\pi/4$ -DQPSK, 8DPSK for Bluetooth (BDR/EDR)
Antenna Type	: Internal Antenna, max gain 1dBi
Software version	: V1.0
Hardware version	: V1.0

Remark:

1. The worst-case simultaneous transmission configuration was evaluated with no non-compliance found. Results in this report are only for Bluetooth EDR function, and there is no other transmitter involved.

2.2. Accessories of Device (EUT)

Accessories1 : /
 Manufacturer : /
 Model : /
 INPUT : /
 OUTPUT : /

2.3. Tested Supporting System Details

No.	Description	Manufacturer	Model	Serial Number	Certification or SDOC
1.	N/A	N/A	N/A	N/A	N/A

2.4. Block Diagram of connection between EUT and simulators

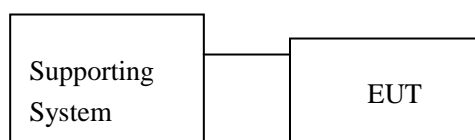

2.5. Test Mode Description

The test software “RFTestTool.app” was used to control EUT work in Continuous TX mode, and select test channel, wireless mode

Tested mode, channel, and data rate information		
Mode	Channel	Frequency (MHz)
Carrier Tx Mode	CH0	2402
	CH39	2441
	CH78	2480
GFSK / Pi/4-DQPSK / 8-DPSK hopping on Tx Mode	CH0 to CH78	2402 to 2480
GFSK / Pi/4-DQPSK / 8-DPSK hopping off Tx Mode	CH0	2402
	CH39	2441
	CH78	2480

2.6. Test Conditions

Items	Required	Actual
Temperature range:	15-35°C	25°C
Humidity range:	25-75%	56%
Pressure range:	86-106kPa	98kPa

2.7. Test Facility

Shenzhen Alpha Product Testing Co., Ltd

Building i, No.2, Lixin Road, Fuyong Street, Bao'an District, 518103,
Shenzhen, Guangdong, China

June 21, 2018 File on Federal Communication Commission

Registration Number: 293961

Designation Number: CN1236

July 15, 2019 Certificated by IC

Registration Number: CN0085

2.8. Measurement Uncertainty

(95% confidence levels, k=2)

Item	Uncertainty
Uncertainty for Power point Conducted Emissions Test	2.74dB
Uncertainty for Radiation Emission test in 3m chamber (below 30MHz)	2.13 dB(Polarize: V)
	2.57dB(Polarize: H)
Uncertainty for Radiation Emission test in 3m chamber (30MHz to 1GHz)	3.77dB(Polarize: V)
	3.80dB(Polarize: H)
Uncertainty for Radiation Emission test in 3m chamber (1GHz to 25GHz)	4.16dB(Polarize: H)
	4.13dB(Polarize: V)
Uncertainty for radio frequency	5.4×10^{-8}
Uncertainty for conducted RF Power	0.37dB
Uncertainty for temperature	0.2°C
Uncertainty for humidity	1%
Uncertainty for DC and low frequency voltages	0.06%

2.9. Test Equipment List

Equipment	Manufacture	Model No.	Serial No.	Last cal.	Cal Interval
9*6*6 anechoic chamber	CHENYU	9*6*6	N/A	2020.09.02	3Year
Spectrum analyzer	ROHDE&SCHWARZ	FSV40-N	102137	2021.08.25	1Year
Spectrum analyzer	Agilent	N9020A	MY499100060	2021.08.25	1Year
Receiver	ROHDE&SCHWARZ	ESR	1316.3003K03-10208 2-Wa	2021.08.25	1Year
Receiver	R&S	ESCI	101165	2021.08.25	1Year
Bilog Antenna	Schwarzbeck	VULB 9168	VULB9168-438	2020.04.12	2Year
Horn Antenna	SCHWARZBECK	BBHA 9120 D	BBHA 9120 D(1201)	2020.04.12	2Year
Active Loop Antenna	SCHWARZBECK	FMZB 1519B	00059	2021.08.30	2Year
RF Cable	Resenberger	Cable 1	RE1	2021.08.25	1Year
RF Cable	Resenberger	Cable 2	RE2	2021.08.25	1Year
RF Cable	Resenberger	Cable 3	CE1	2021.08.25	1Year
Pre-amplifier	HP	HP8347A	2834A00455	2021.08.25	1Year
Pre-amplifier	Agilent	8449B	3008A02664	2021.08.25	1Year
L.I.S.N.#1	Schwarzbeck	NSLK8126	8126-466	2021.08.25	1Year
L.I.S.N.#2	ROHDE&SCHWARZ	ENV216	101043	2021.08.25	1Year
Horn Antenna	SCHWARZBECK	BBHA9170	00946	2021.08.30	2Year
Preamplifier	SKET	LNPA_1840-50	SK2018101801	2021.08.25	1Year
Power Meter	Agilent	E9300A	MY41496628	2021.08.25	1Year
Power Sensor	DARE	RPR3006W	15100041SNO91	2021.08.25	1Year
Temp. & Humid. Chamber	Weihuang	WHTH-1000-40-8 80	100631	2021.04.21	1Year
Switching Mode Power Supply	JUNKE	JK12010S	20140927-6	2021.08.25	1Year

3. Maximum Peak Output Power

3.1.Limit

Please refer FCC part 15.247 & RSS-247..

For frequency hopping systems operating in the 2400-2483.5 MHz band employing at least 75 non-overlapping hopping channels, and all frequency hopping systems in the 5725-5850 MHz band: 1 watt. For all other frequency hopping systems in the 2400-2483.5 MHz band: 0.125 watts, the e.i.r.p shall not exceed 4W

3.2.Test Procedure

The transmitter output is connected to the RF Power meter. The Power meter is set to the peak power detection.

3.3.Test Setup

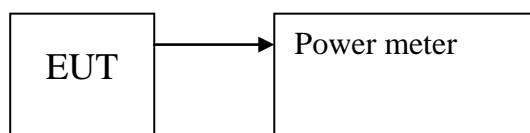

3.4.Test Result

Mode	Freq (MHz)	PK Output Power (dBm)	Limit (dBm)	Result
GFSK	2402	-0.409	21	Pass
	2441	-1.717	21	Pass
	2480	-2.417	21	Pass
$\pi/4$ DQPSK	2402	1.787	21	Pass
	2441	0	21	Pass
	2480	-1.506	21	Pass
8- DPSK	2402	0.951	21	Pass
	2441	-0.694	21	Pass
	2480	-0.998	21	Pass
Conclusion: PASS				

4. Bandwidth

4.1.Limit

Intentional radiators operating under the alternative provisions to the general emission limits, as contained in RSS-GEN, FCC Section 15.247(a)(1), must be designed to ensure that the 20 dB bandwidth of the emission, or whatever bandwidth may otherwise be specified in the specific rule section under which the equipment operates, is contained within the frequency band designated in the rule section under which the equipment is operated.

4.2.Test Procedure

The RF output of EUT was connected to the spectrum analyzer by RF cable and attenuator. The bandwidth of the fundamental frequency was measured by spectrum analyzer with 30kHz RBW and 100kHz VBW. The 20dB bandwidth is defined as the total spectrum the power of which is higher than peak power minus 20dB.

4.3.Test Result

Condition	Mode	Frequency (MHz)	Antenna	99% OBW (MHz)	-20 dB Bandwidth (MHz)	Limit -20 dB Bandwidth (MHz)	Verdict
NVNT	1-DH1	2402	Ant 1	0.775	0.804	/	Pass
NVNT	1-DH1	2441	Ant 1	0.787	0.848	/	Pass
NVNT	1-DH1	2480	Ant 1	0.775	0.828	/	Pass
NVNT	2-DH1	2402	Ant 1	1.157	1.238	/	Pass
NVNT	2-DH1	2441	Ant 1	1.149	1.234	/	Pass
NVNT	2-DH1	2480	Ant 1	1.157	1.248	/	Pass
NVNT	3-DH1	2402	Ant 1	1.153	1.206	/	Pass
NVNT	3-DH1	2441	Ant 1	1.159	1.21	/	Pass
NVNT	3-DH1	2480	Ant 1	1.141	1.194	/	Pass

OBW NVNT 1-DH1 2402MHz Ant1

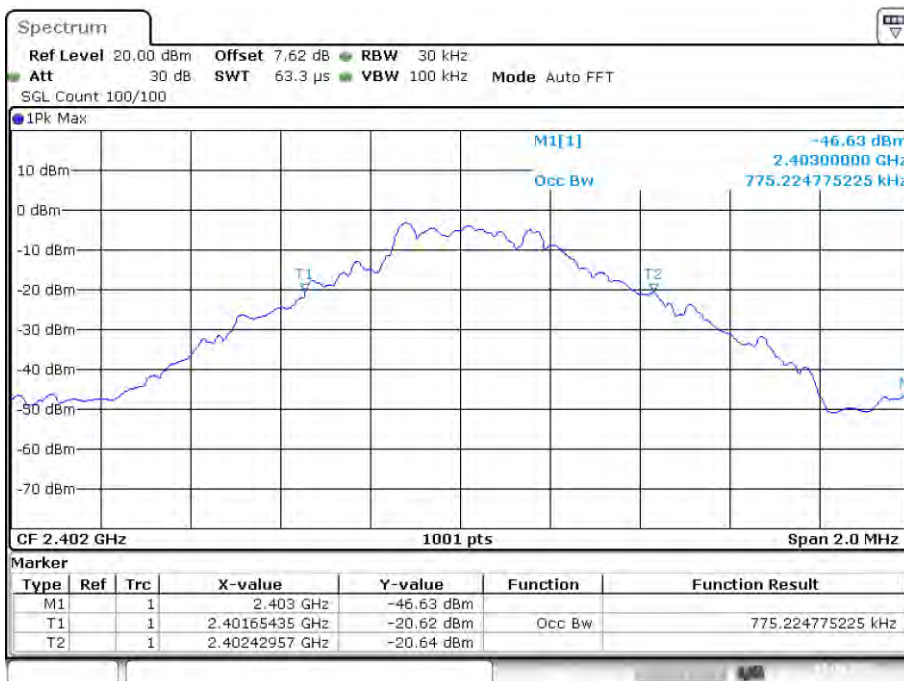

Date: 7.MAR.2022 11:18:04

-20 dB BW NVNT 1-DH1 2402MHz Ant1

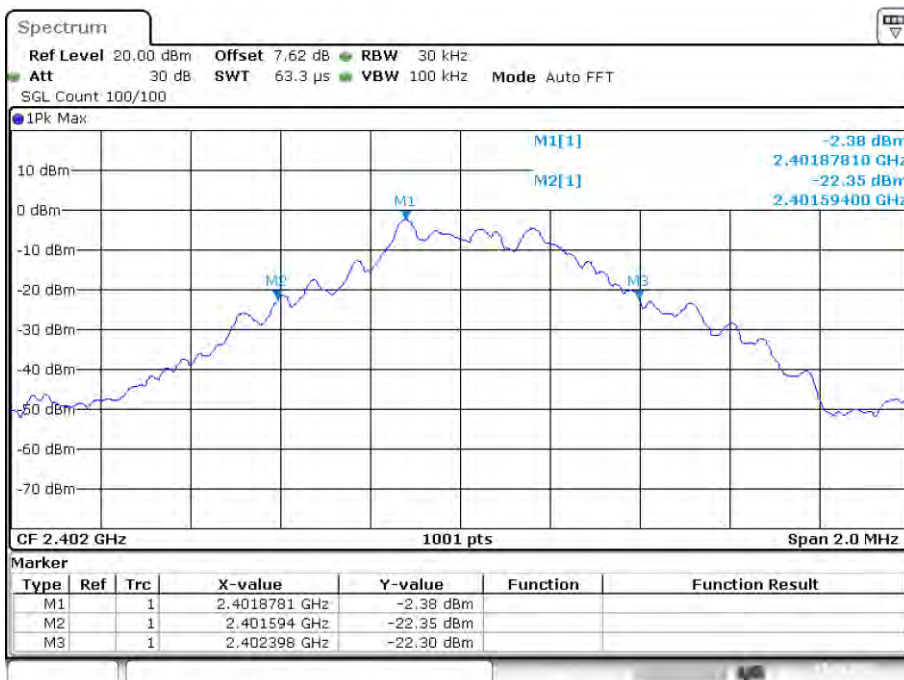

Date: 7.MAR.2022 11:18:12

OBW NVNT 1-DH1 2441MHz Ant1

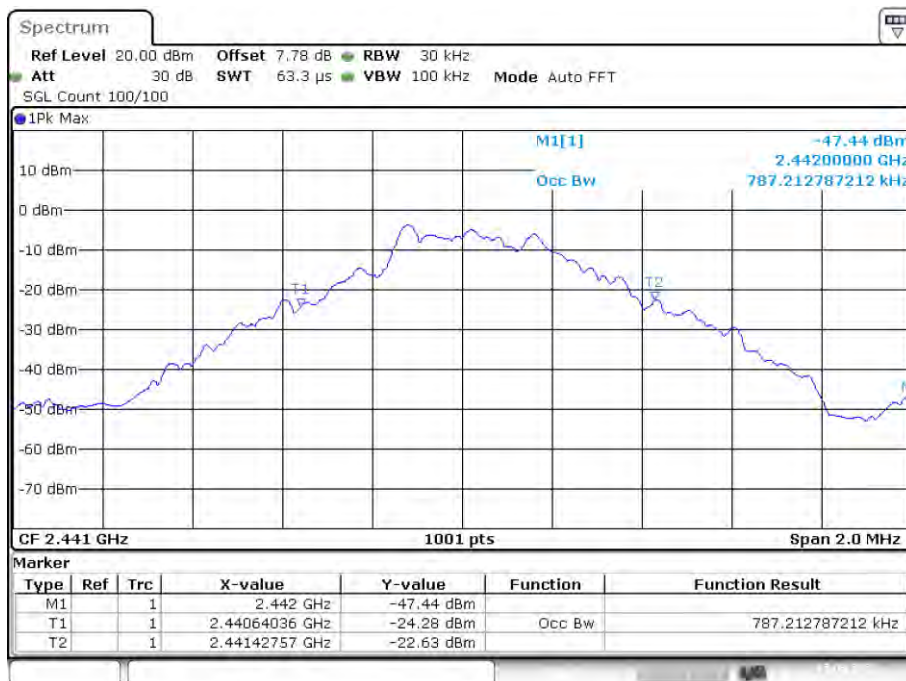

Date: 7.MAR.2022 11:19:50

-20 dB BW NVNT 1-DH1 2441MHz Ant1



Date: 7.MAR.2022 11:19:58

OBW NVNT 1-DH1 2480MHz Ant1

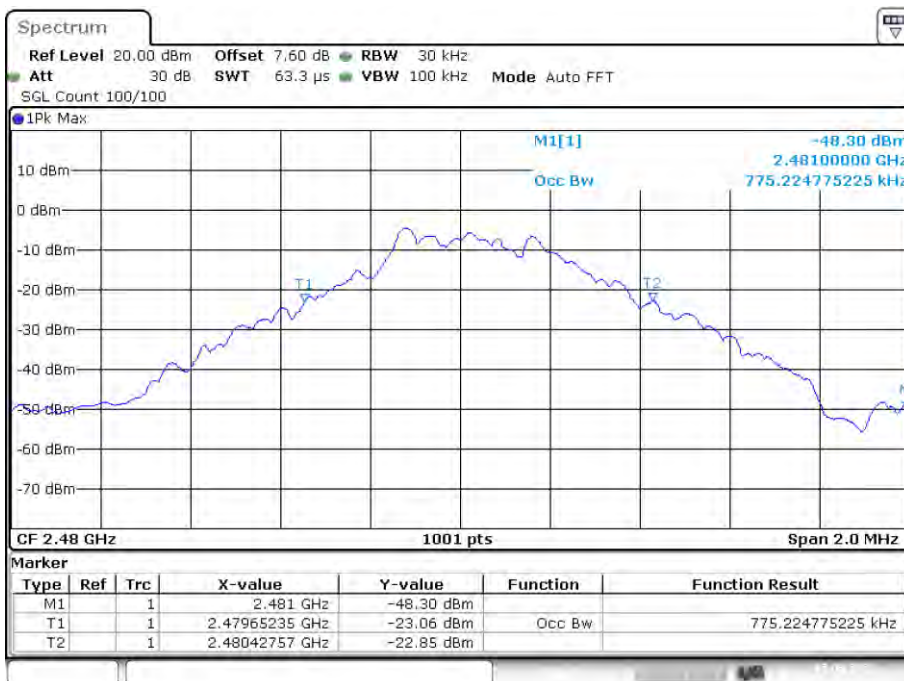

Date: 7.MAR.2022 11:21:06

-20 dB BW NVNT 1-DH1 2480MHz Ant1



Date: 7.MAR.2022 11:21:17

OBW NVNT 2-DH1 2402MHz Ant1

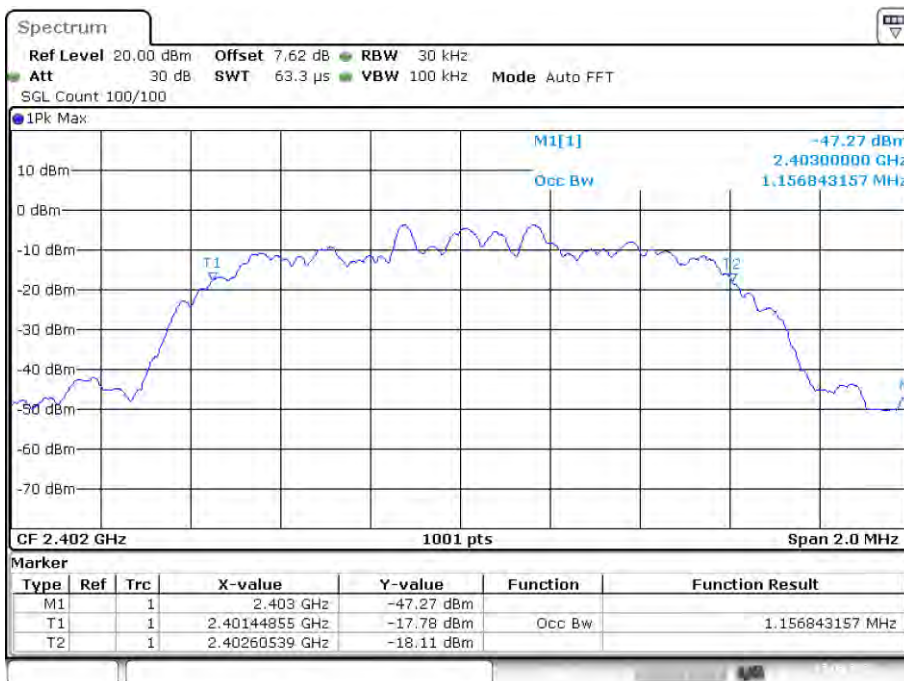

Date: 7.MAR.2022 11:37:21

-20 dB BW NVNT 2-DH1 2402MHz Ant1

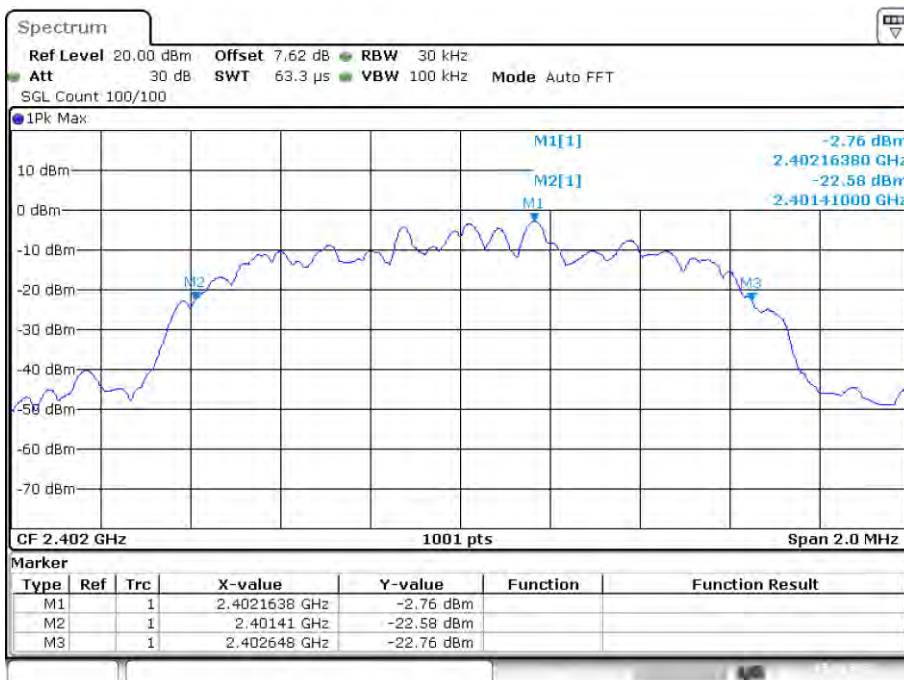

Date: 7.MAR.2022 11:37:33

OBW NVNT 2-DH1 2441MHz Ant1

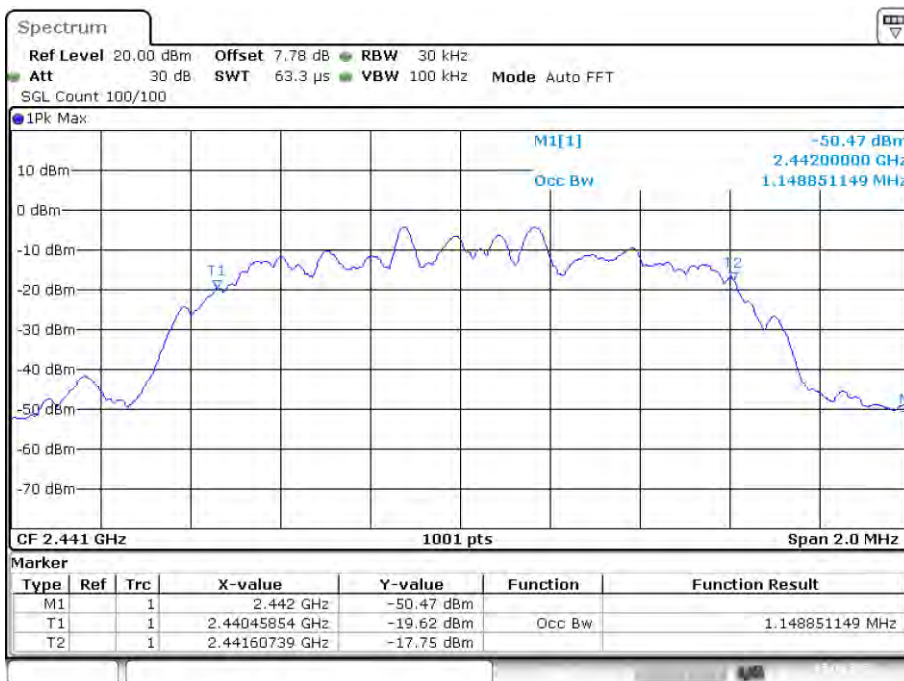

Date: 7.MAR.2022 11:28:36

-20 dB BW NVNT 2-DH1 2441MHz Ant1

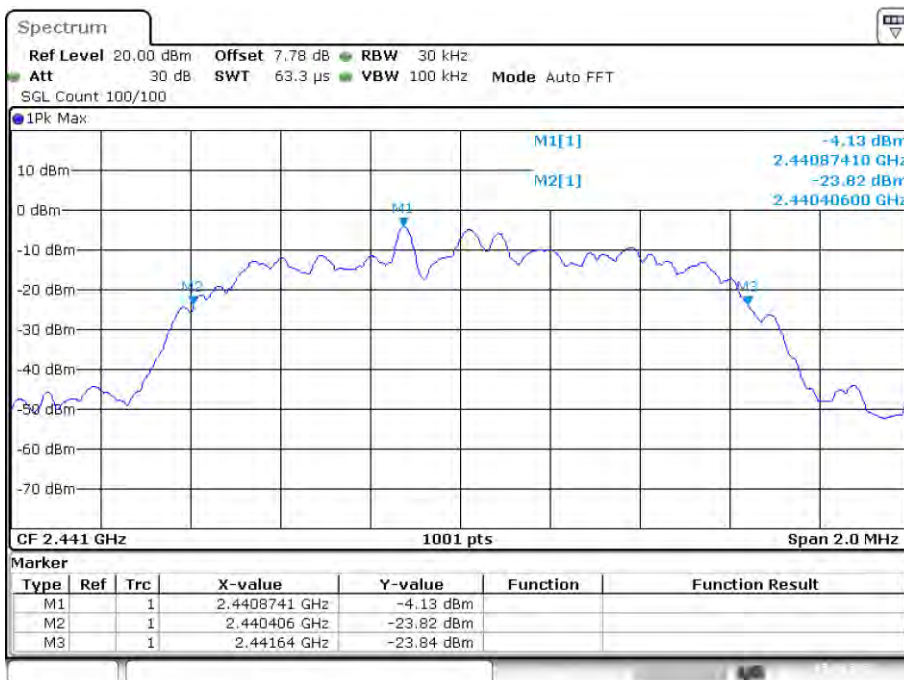

Date: 7.MAR.2022 11:28:47

OBW NVNT 2-DH1 2480MHz Ant1

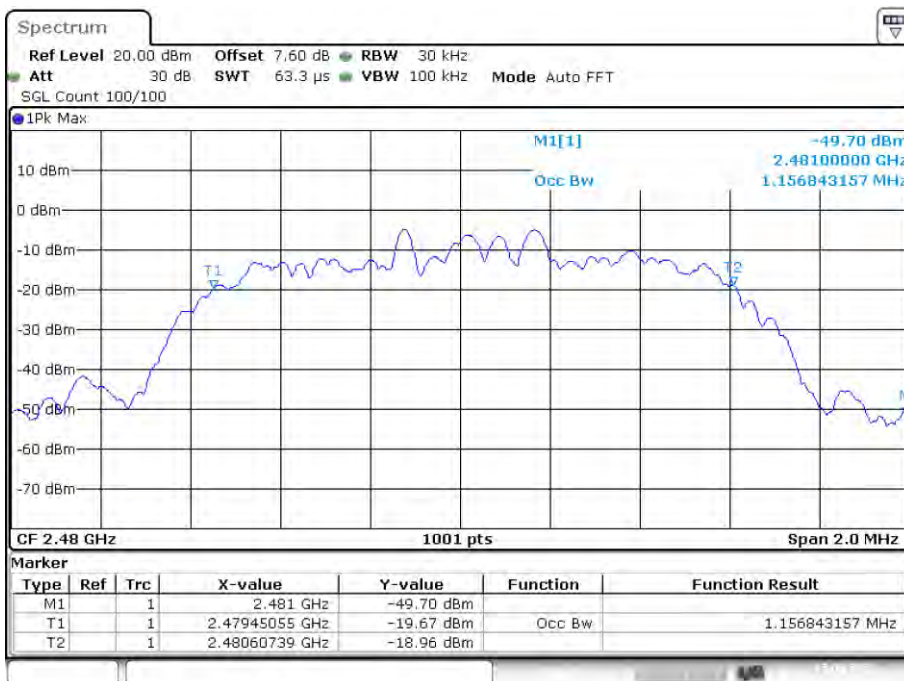

Date: 7.MAR.2022 11:35:34

-20 dB BW NVNT 2-DH1 2480MHz Ant1

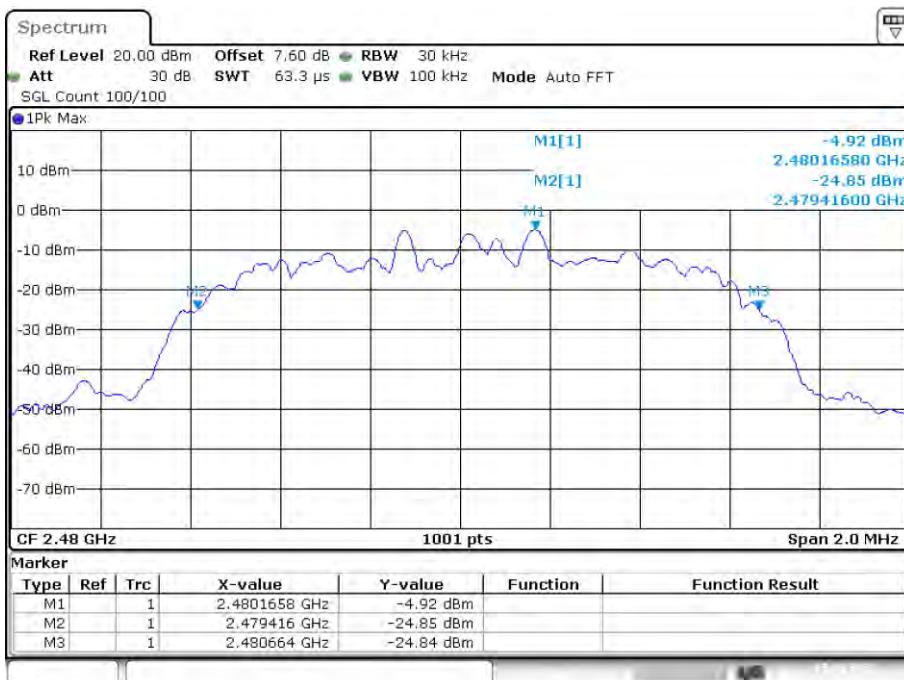

Date: 7.MAR.2022 11:35:45

OBW NVNT 3-DH1 2402MHz Ant1

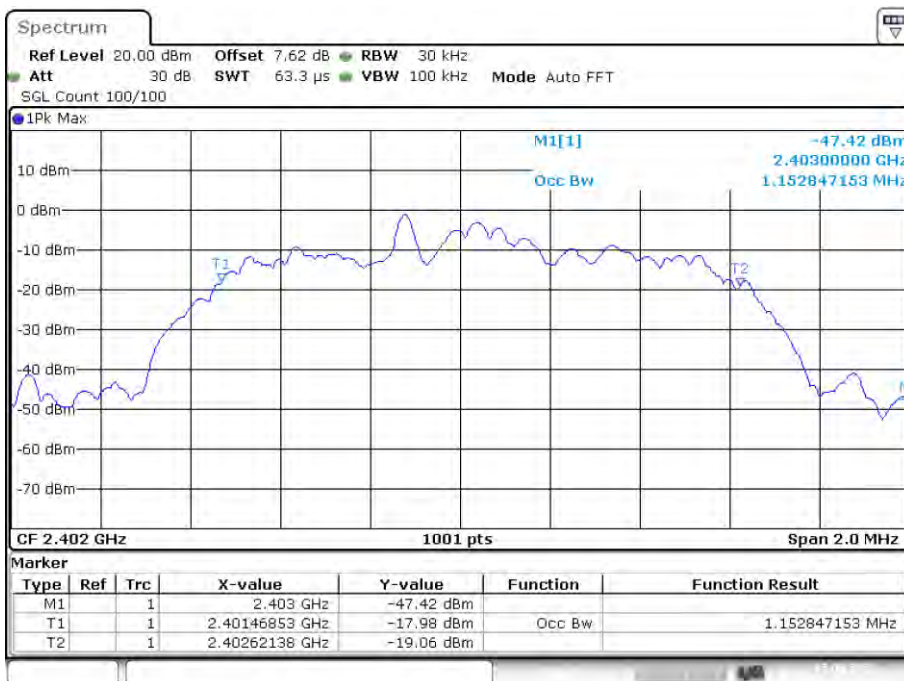

Date: 7.MAR.2022 11:39:32

-20 dB BW NVNT 3-DH1 2402MHz Ant1

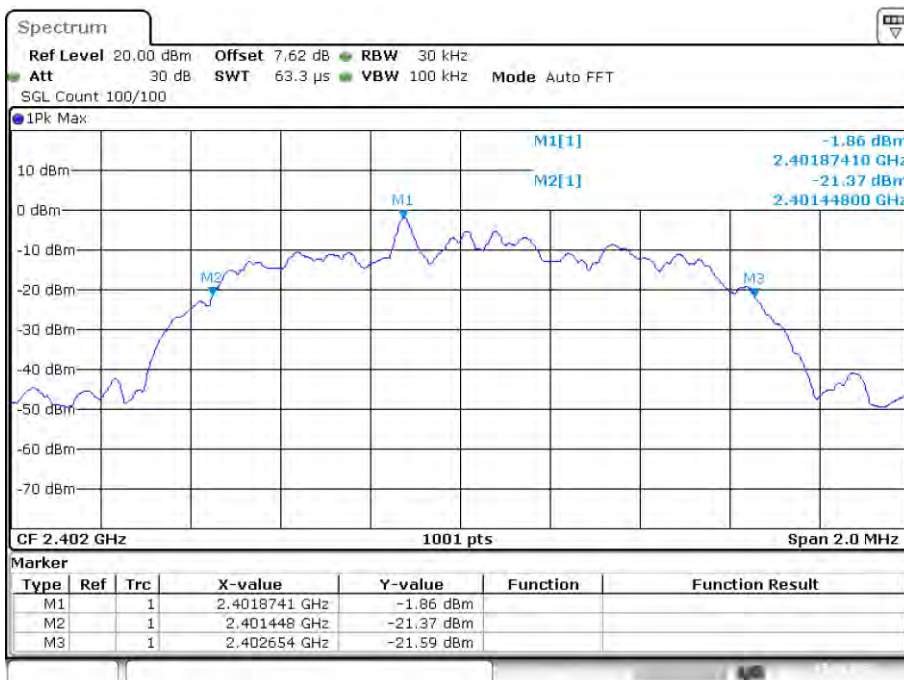

Date: 7.MAR.2022 11:39:45

OBW NVNT 3-DH1 2441MHz Ant1

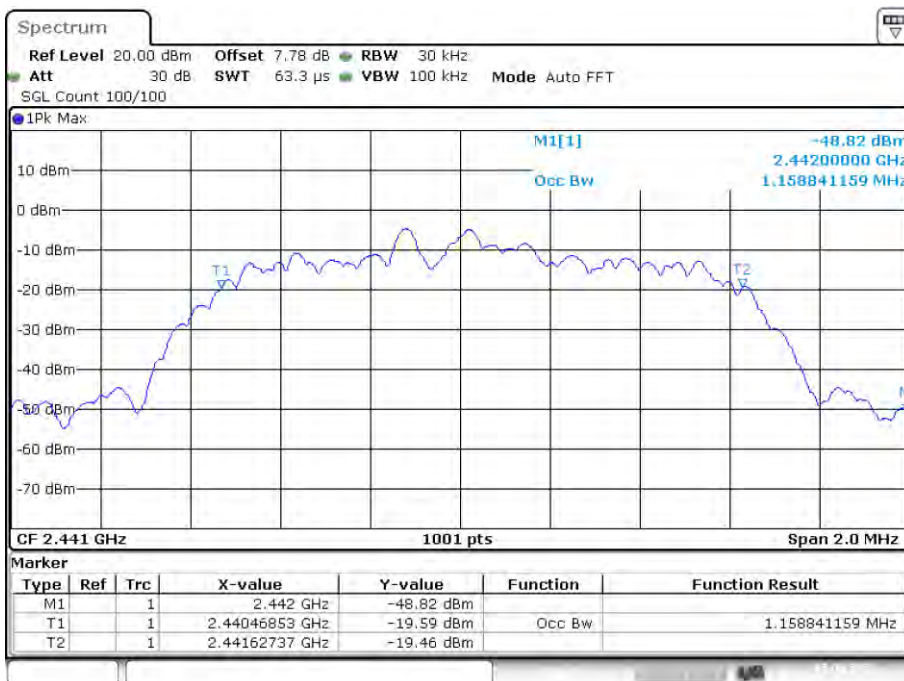

Date: 7.MAR.2022 11:31:32

-20 dB BW NVNT 3-DH1 2441MHz Ant1

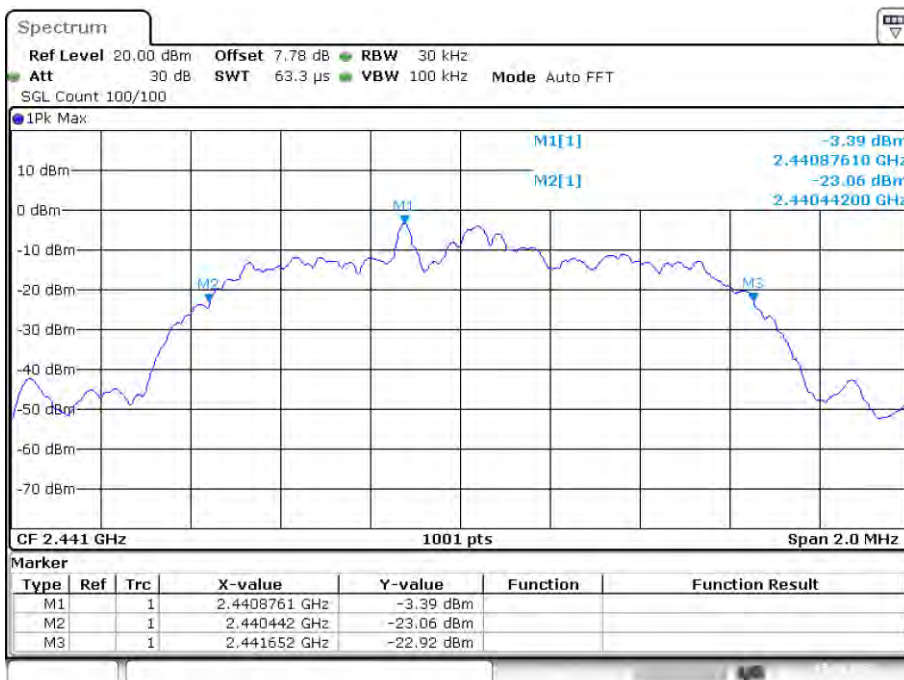

Date: 7.MAR.2022 11:31:43

OBW NVNT 3-DH1 2480MHz Ant1

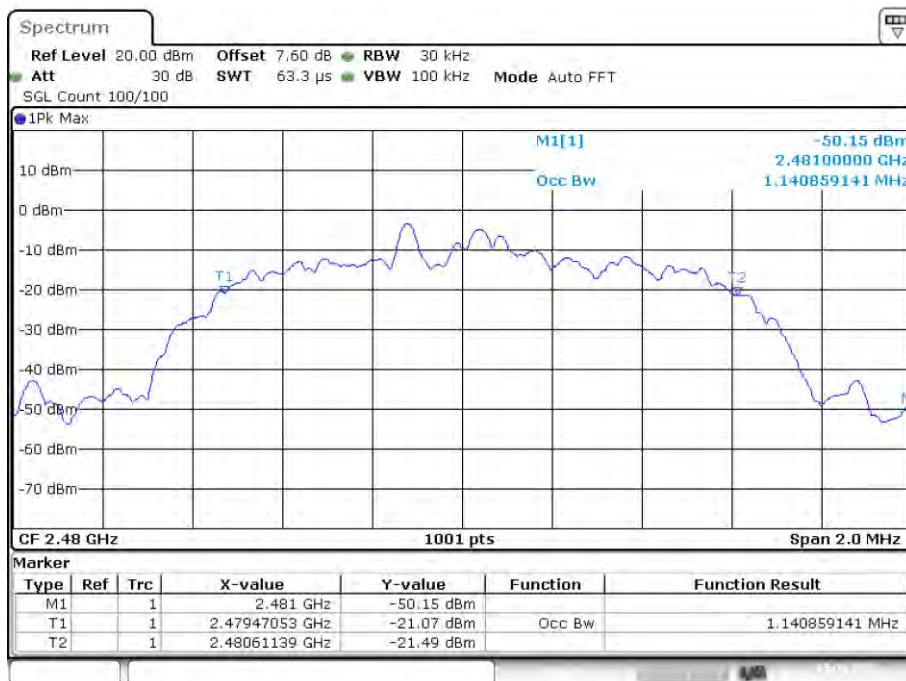

Date: 7.MAR.2022 11:34:00

-20 dB BW NVNT 3-DH1 2480MHz Ant1

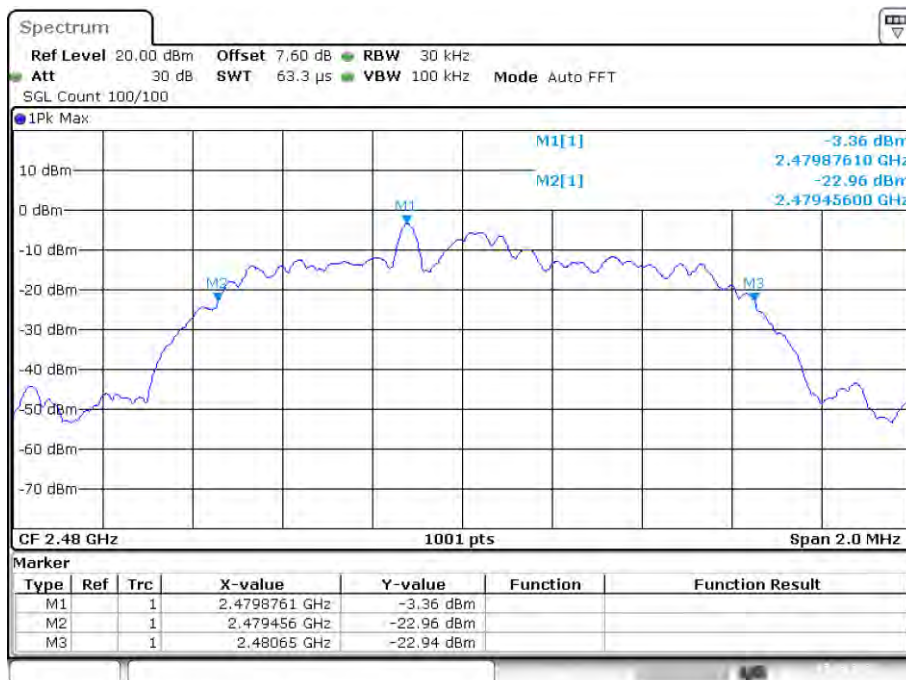

Date: 7.MAR.2022 11:34:11

5. Carrier Frequency Separation

5.1.Limit

Frequency hopping systems shall have hopping channel carrier frequencies separated by a minimum of 25 kHz or the 20 dB bandwidth of the hopping channel, whichever is greater. Alternatively, frequency hopping systems operating in the 2400-2483.5 MHz band may have hopping channel carrier frequencies that are separated by 25 kHz or two-thirds of the 20 dB bandwidth of the hopping channel, whichever is greater, provided the systems operate with an output power no greater than 125 mW

5.2.Test Procedure

The RF output of EUT was connected to the spectrum analyzer by RF cable and attenuator. The carrier frequency was measured by spectrum analyzer with 30kHz RBW and 100kHz VBW.

5.3.Test Result

Condition	Mode	Hopping Freq1 (MHz)	Hopping Freq2 (MHz)	HFS (MHz)	Limit (MHz)	Verdict
NVNT	1-DH1	2441.045	2442.047	1.002	0.848	Pass
NVNT	2-DH1	2440.874	2441.876	1.002	0.823	Pass
NVNT	3-DH1	2440.876	2441.878	1.002	0.807	Pass

CFS NVNT 1-DH1 2441MHz Ant1

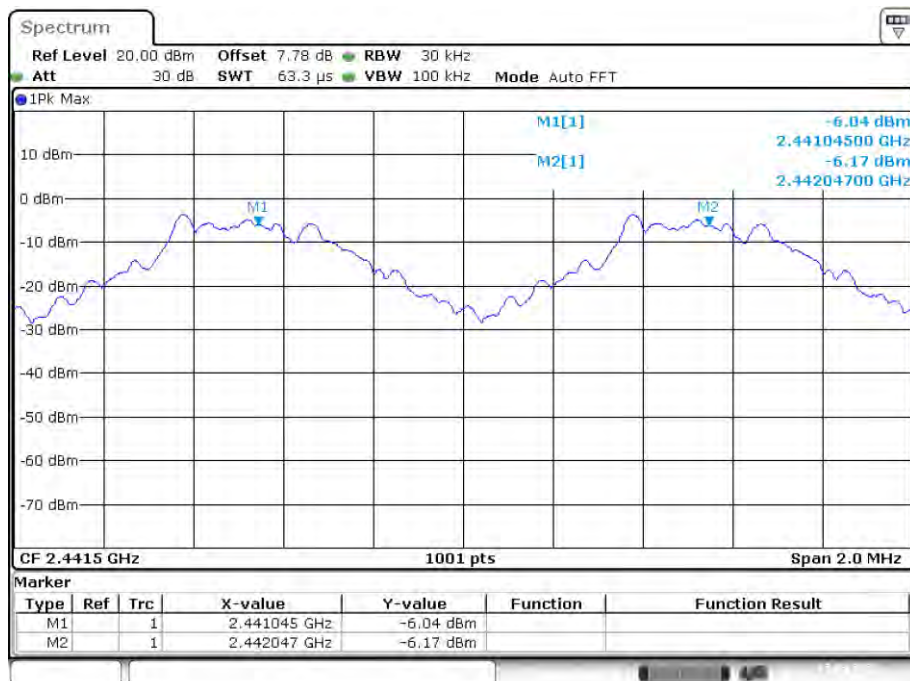

Date: 7.MAR.2022 11:47:50

CFS NVNT 2-DH1 2441MHz Ant1

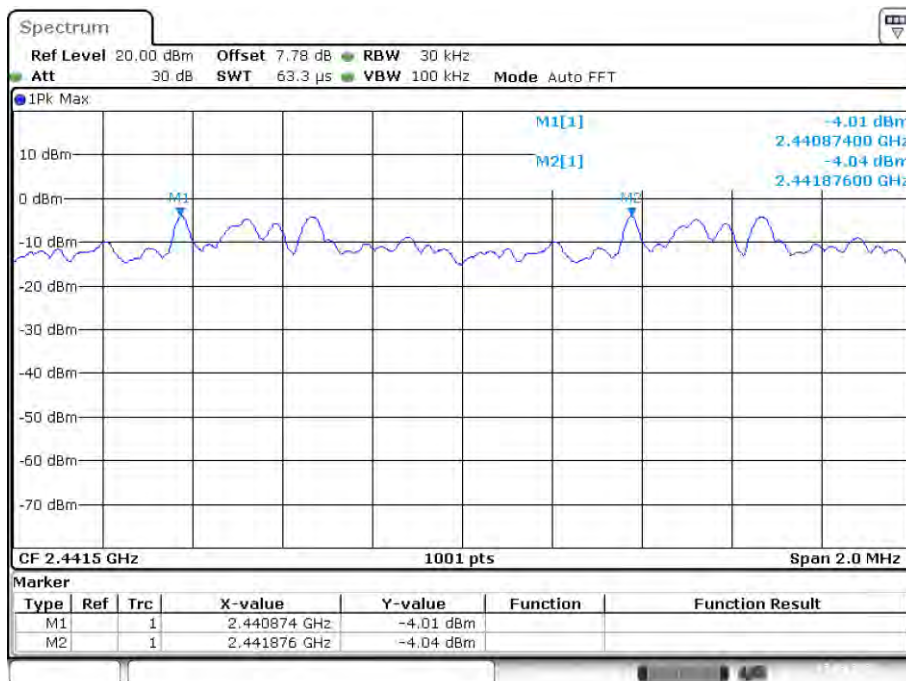

Date: 7.MAR.2022 13:06:42

CFS NVNT 3-DH1 2441MHz Ant1

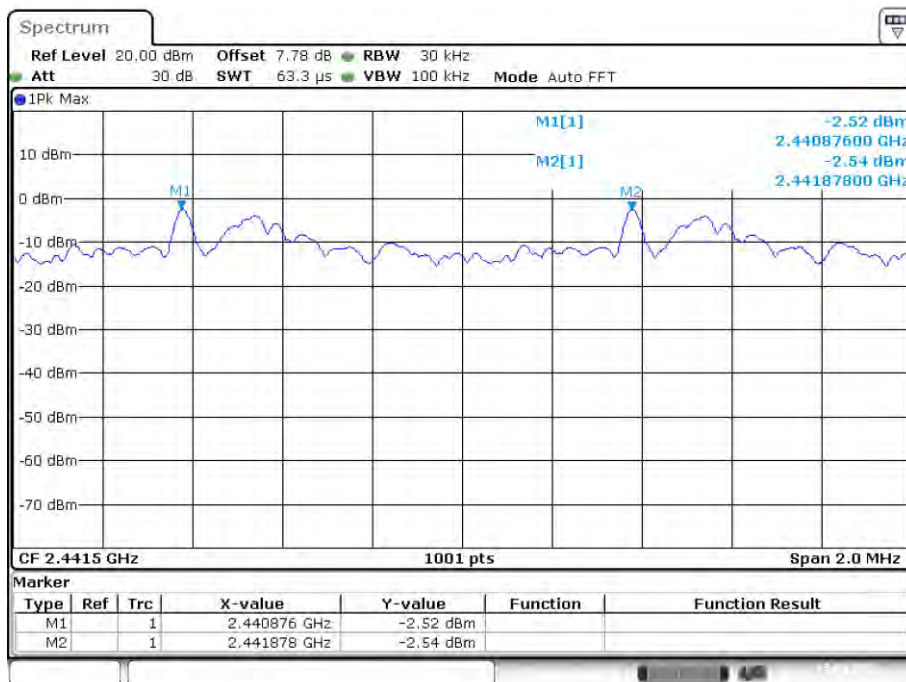

Date: 7.MAR.2022 13:22:27

6. Number Of Hopping Channel

6.1.Limit

Frequency hopping systems in the 2400-2483.5 MHz band shall use at least 15 channels

6.2.Test Procedure

The RF output of EUT was connected to the spectrum analyzer by RF cable and attenuator. The number of hopping channel was measured by spectrum analyzer with 100kHz RBW and 300KHz VBW.

6.3.Test Result

Condition	Mode	Hopping Number	Limit	Verdict
NVNT	1-DH1	79	15	Pass
NVNT	2-DH1	79	15	Pass
NVNT	3-DH1	79	15	Pass

Hopping No. NVNT 1-DH1 2441MHz Ant1

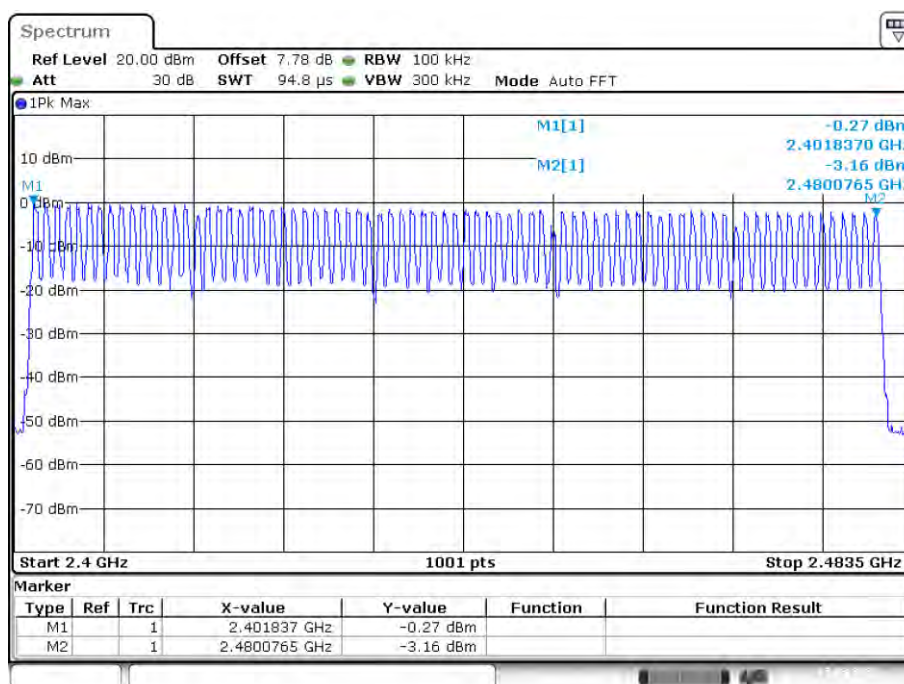

Date: 7.MAR.2022 11:50:17

Hopping No. NVNT 2-DH1 2441MHz Ant1

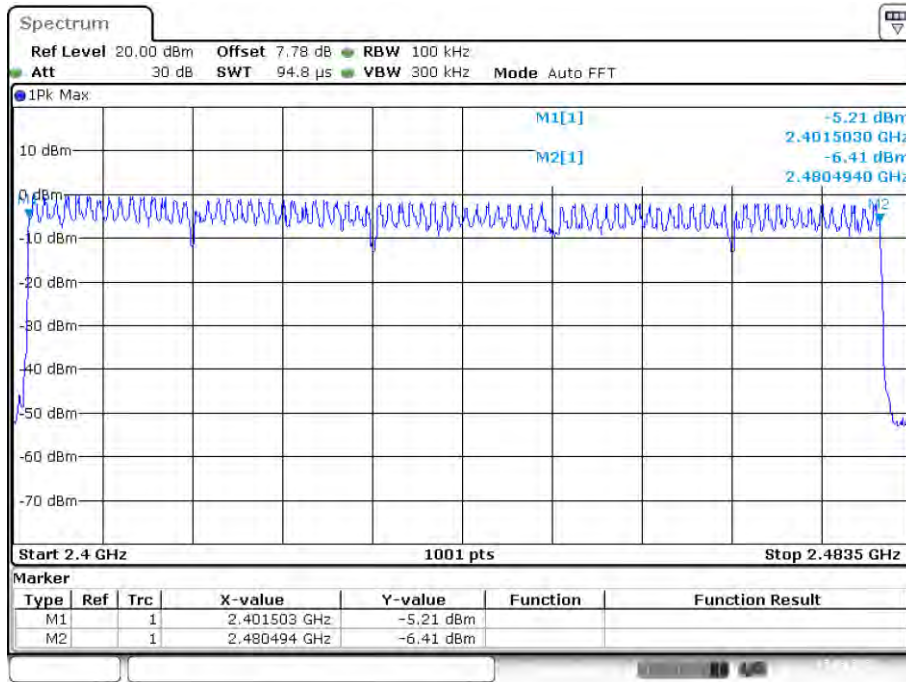

Date: 7.MAR.2022 13:09:43

Hopping No. NVNT 3-DH1 2441MHz Ant1

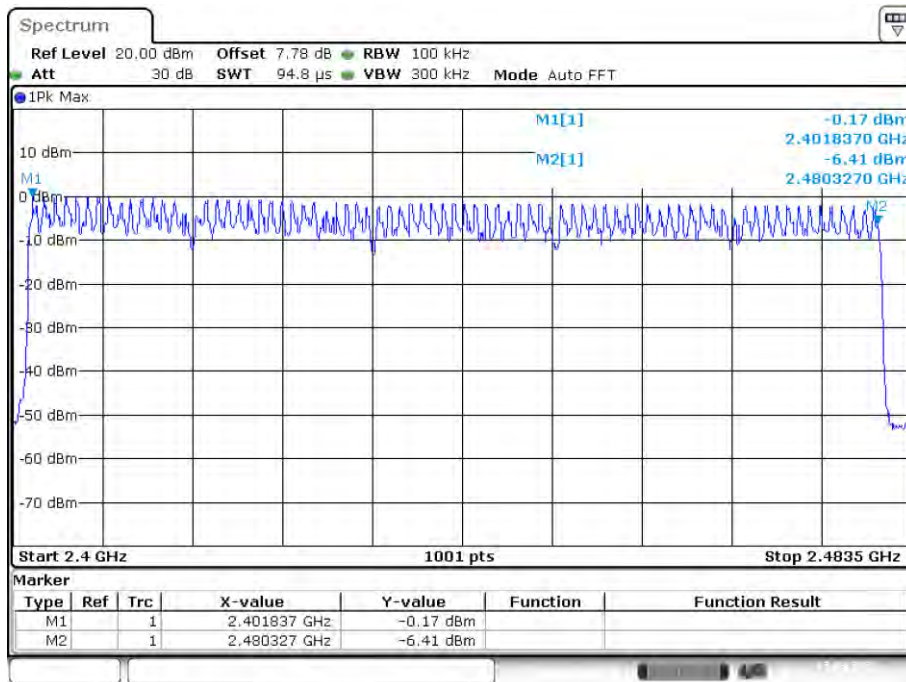

Date: 7.MAR.2022 13:24:12

7. Dwell Time

7.1. Test limit

Please refer FCC part 15.247 & RSS-247.

Frequency hopping systems operating in the 2400MHz-2483.5 MHz. The average time of occupancy on any frequency shall not greater than 0.4 s within period of 0.4 seconds multiplied by the number of hopping channel employed.

7.2. Test Procedure

7.2.1. Place the EUT on the table and set it in transmitting mode.

7.2.2. Remove the antenna from the EUT and then connect a low loss RF cable from the antenna port to the spectrum analyzer.

7.2.3. Set center frequency of spectrum analyzer = operating frequency.

7.2.4. Set the spectrum analyzer as RBW, VBW=1MHz, Span = 0Hz, Sweep = auto.

7.2.5. Repeat above procedures until all frequency measured were complete.

7.3. Test Result

PASS.

Detailed information please see the following page.

Condition	Mode	Frequency (MHz)	Antenna	Pulse Time (ms)	Total Dwell Time (ms)	Period Time (ms)	Limit (ms)	Verdict
NVNT	1-DH1	2402	Ant1	0.389	124.480	31600	400	Pass
NVNT	1-DH1	2441	Ant1	0.388	124.160	31600	400	Pass
NVNT	1-DH1	2480	Ant1	0.386	123.520	31600	400	Pass
NVNT	1-DH3	2441	Ant1	1.642	262.720	31600	400	Pass
NVNT	1-DH5	2441	Ant1	2.89	308.267	31600	400	Pass
NVNT	2-DH1	2402	Ant1	0.397	127.040	31600	400	Pass
NVNT	2-DH1	2441	Ant1	0.397	127.040	31600	400	Pass
NVNT	2-DH1	2480	Ant1	0.395	126.400	31600	400	Pass
NVNT	2-DH3	2441	Ant1	1.647	263.520	31600	400	Pass
NVNT	2-DH5	2441	Ant1	2.898	309.120	31600	400	Pass
NVNT	3-DH1	2402	Ant1	0.396	126.720	31600	400	Pass
NVNT	3-DH1	2441	Ant1	0.396	126.720	31600	400	Pass
NVNT	3-DH1	2480	Ant1	0.399	127.680	31600	400	Pass
NVNT	3-DH3	2441	Ant1	1.646	263.360	31600	400	Pass
NVNT	3-DH5	2441	Ant1	2.897	309.013	31600	400	Pass

Dwell NVNT 1-DH1 2402MHz Ant1 One Burst

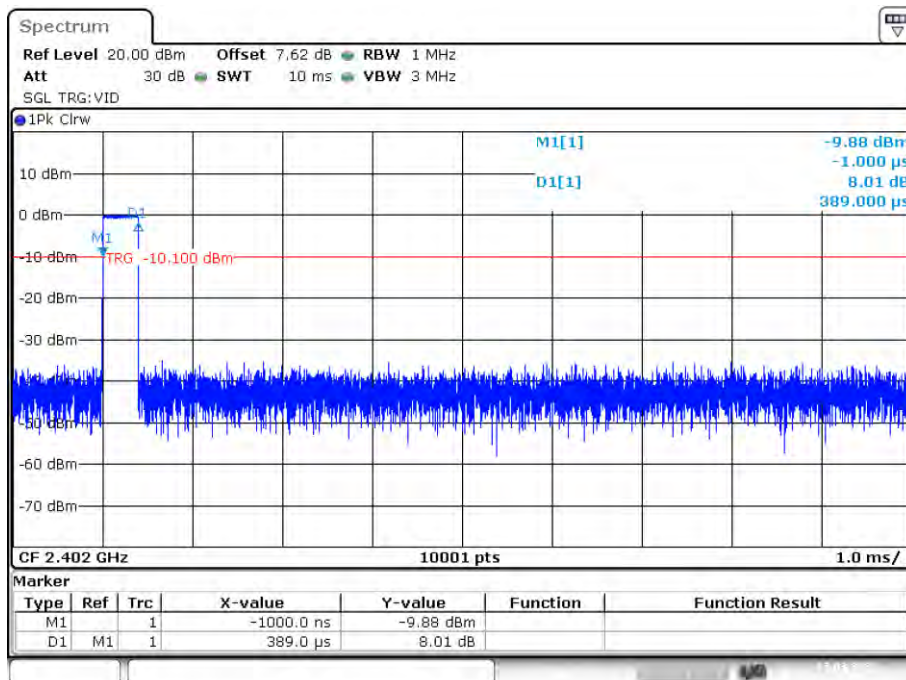

Date: 7.MAR.2022 12:27:41

Dwell NVNT 1-DH1 2402MHz Ant1 Accumulated

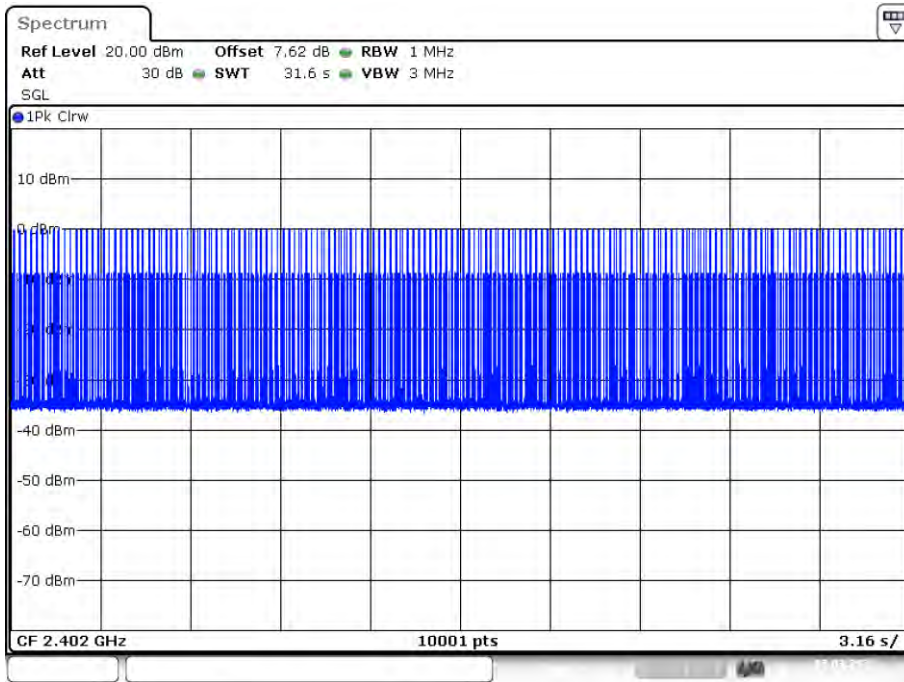

Date: 7.MAR.2022 12:28:15

Dwell NVNT 1-DH1 2441MHz Ant1 One Burst

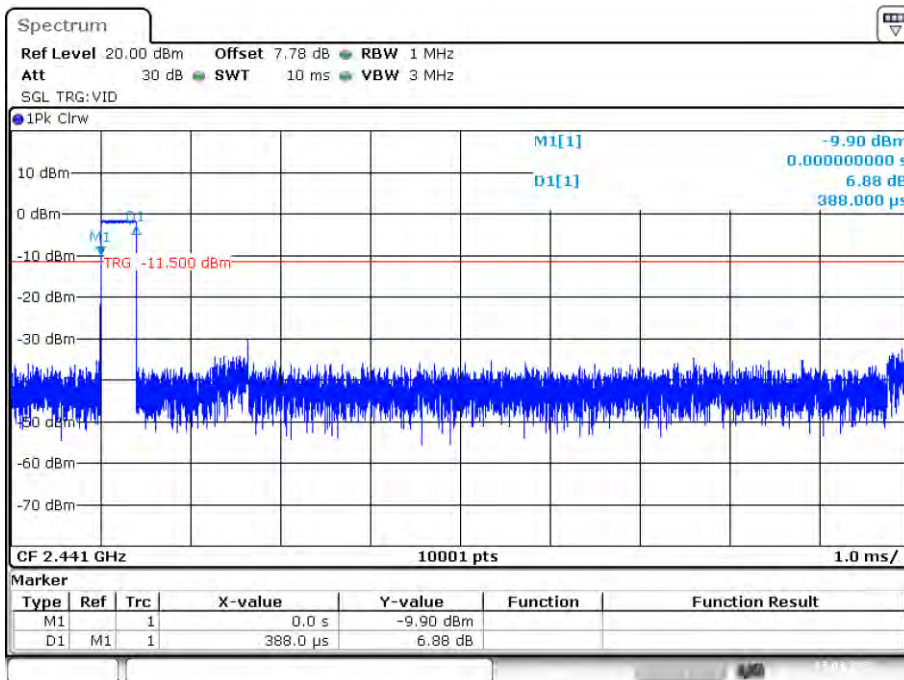

Date: 7.MAR.2022 12:28:50

Dwell NVNT 1-DH1 2441MHz Ant1 Accumulated

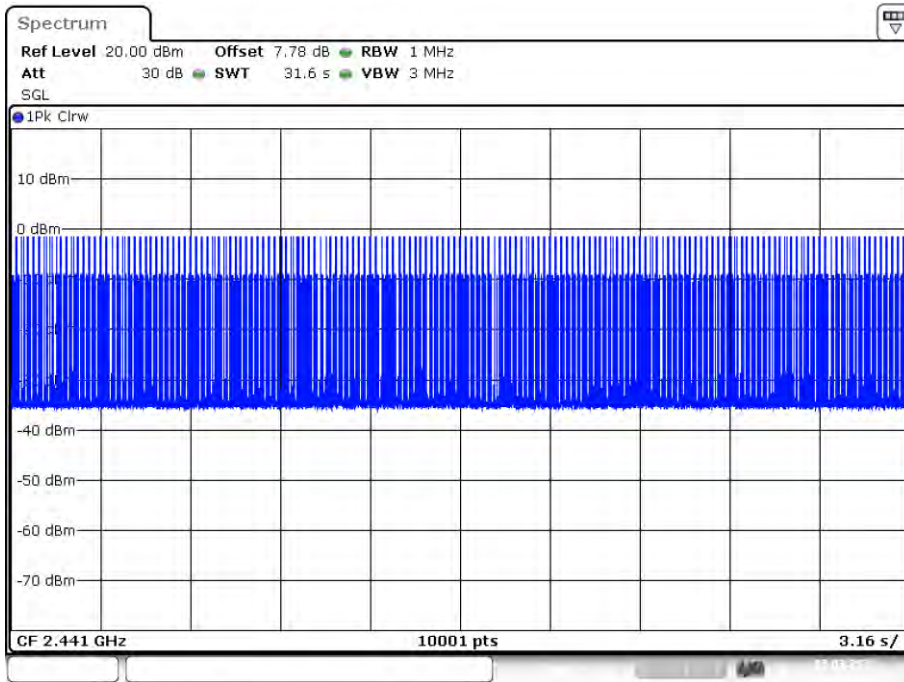

Date: 7.MAR.2022 12:29:25

Dwell NVNT 1-DH1 2480MHz Ant1 One Burst

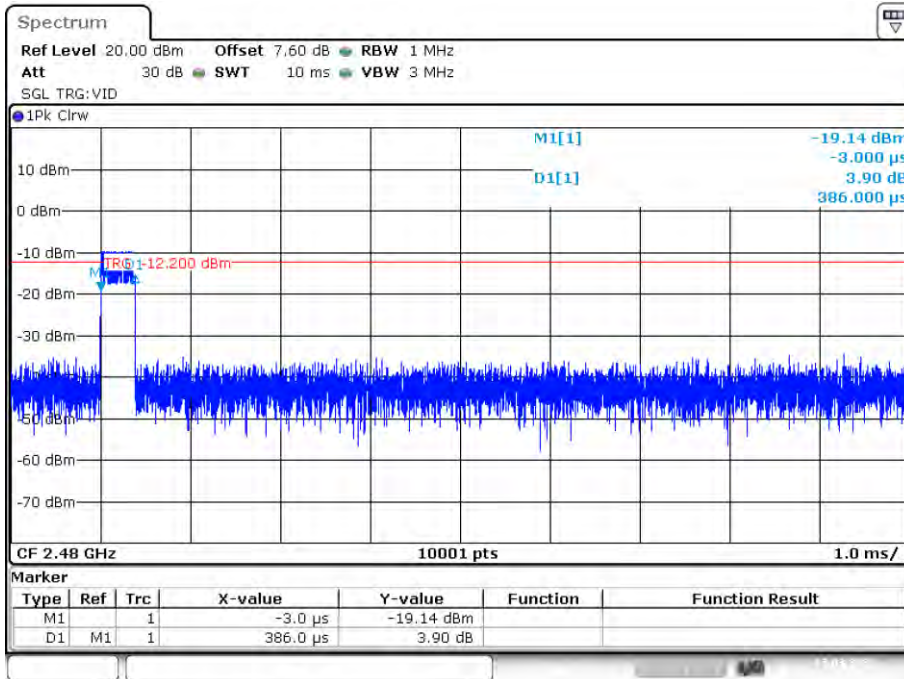

Date: 7.MAR.2022 12:29:54

Dwell NVNT 1-DH3 2441MHz Ant1 Accumulated

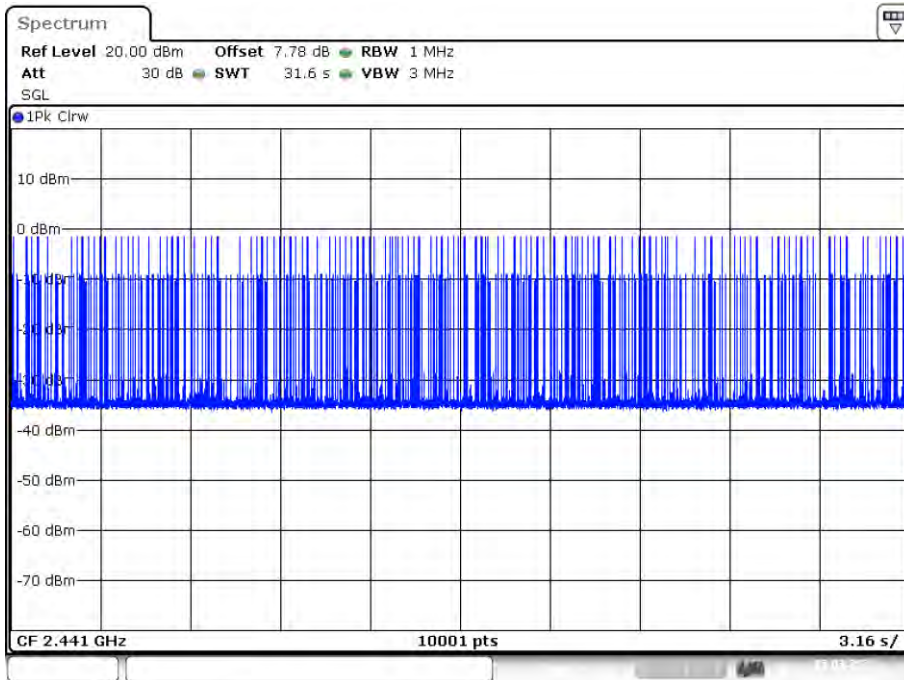

Date: 7.MAR.2022 12:25:34

Dwell NVNT 1-DH5 2441MHz Ant1 One Burst

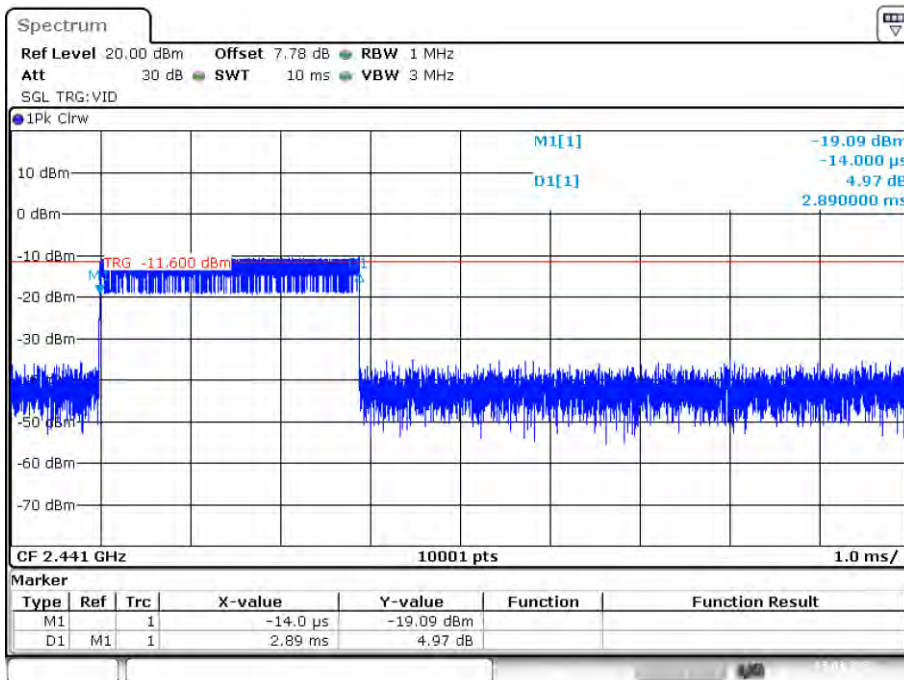

Date: 7.MAR.2022 12:23:43

Dwell NVNT 1-DH5 2441MHz Ant1 Accumulated

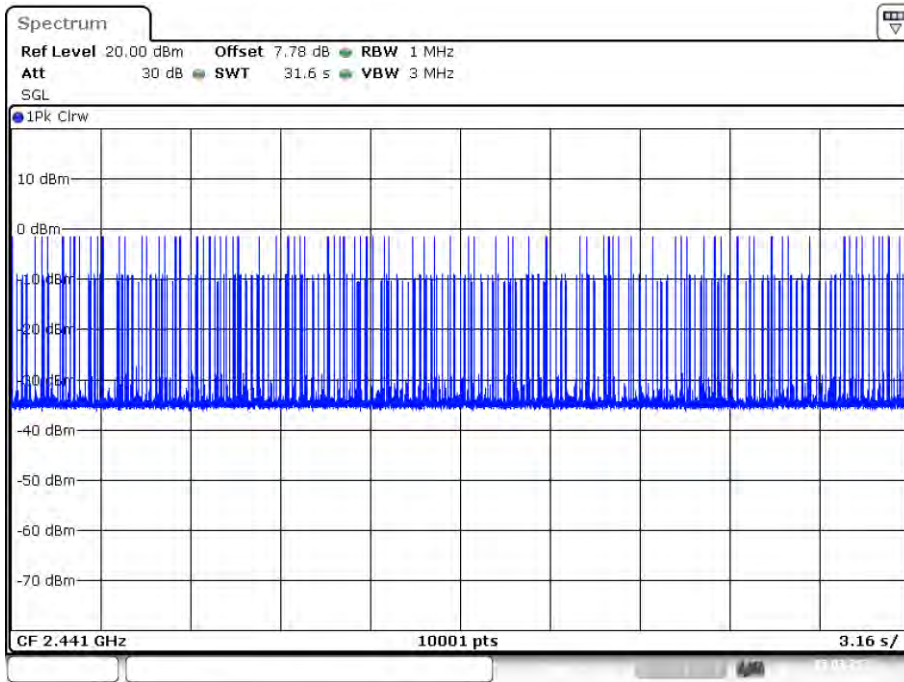

Date: 7.MAR.2022 12:24:18

Dwell NVNT 2-DH1 2402MHz Ant1 One Burst

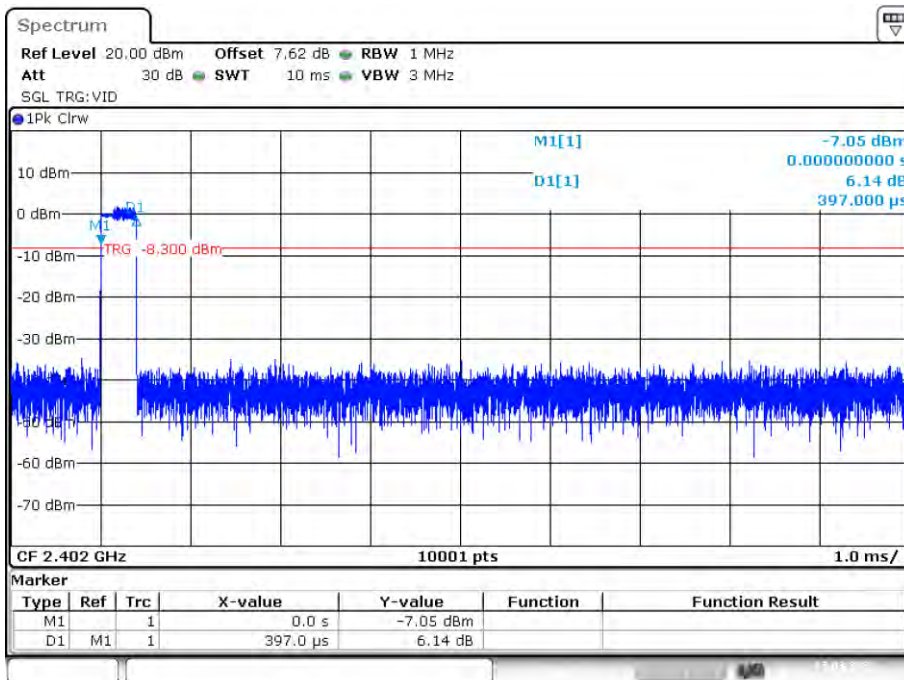

Date: 7.MAR.2022 12:31:31

Dwell NVNT 2-DH1 2402MHz Ant1 Accumulated

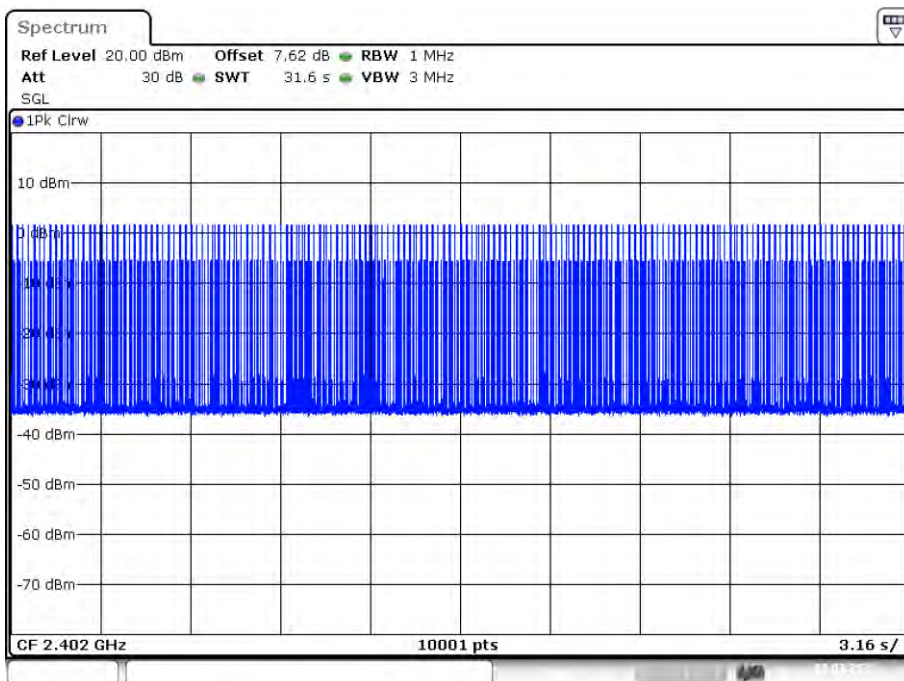

Date: 7.MAR.2022 12:32:06

Dwell NVNT 2-DH1 2441MHz Ant1 One Burst

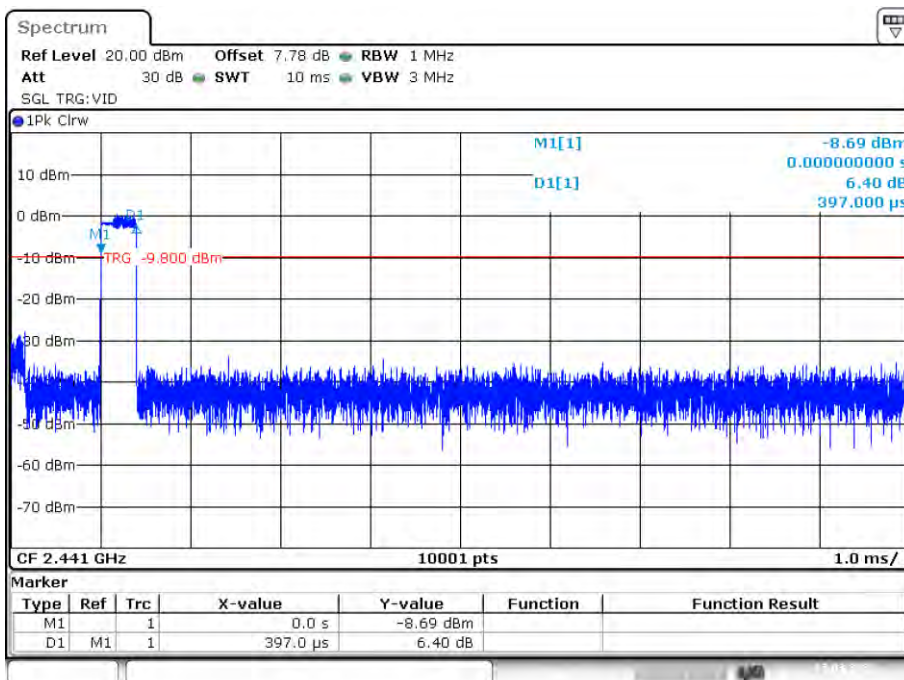

Date: 7.MAR.2022 13:10:01

Dwell NVNT 2-DH1 2441MHz Ant1 Accumulated

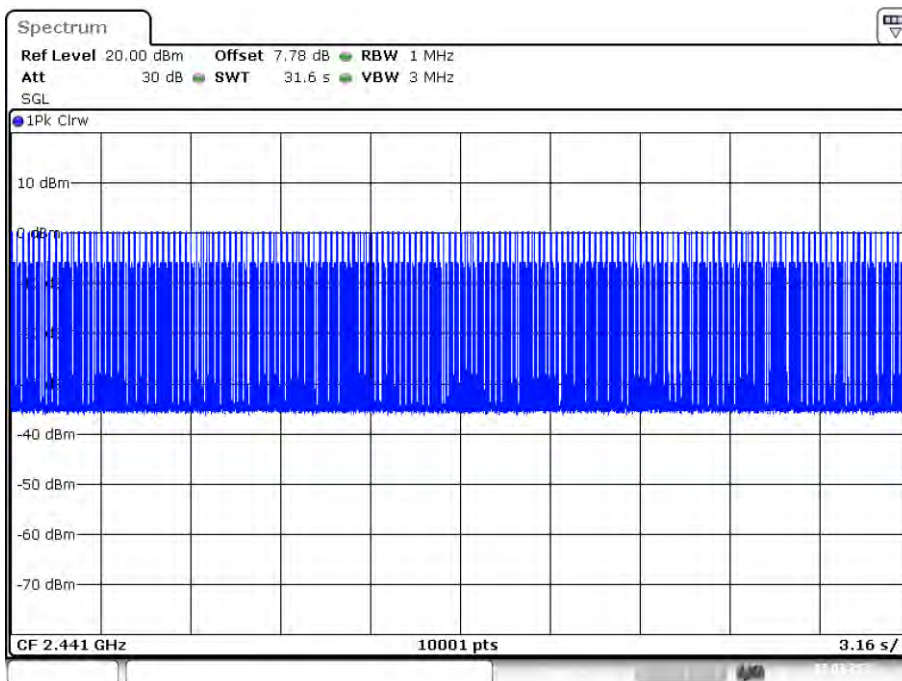

Date: 7.MAR.2022 13:10:35

Dwell NVNT 2-DH1 2480MHz Ant1 One Burst

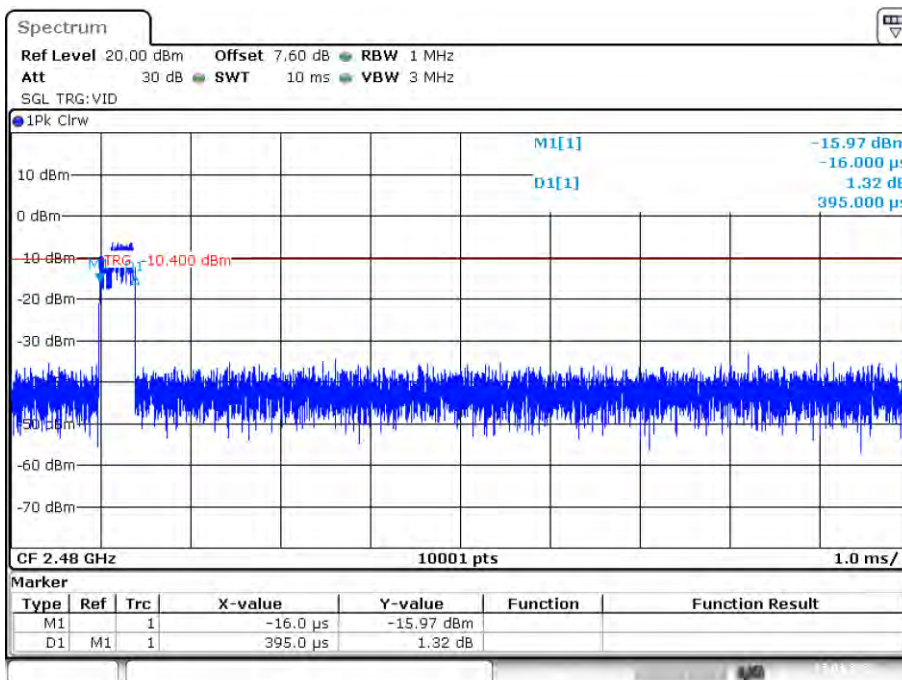

Date: 7.MAR.2022 13:11:41

Dwell NVNT 2-DH3 2441MHz Ant1 Accumulated

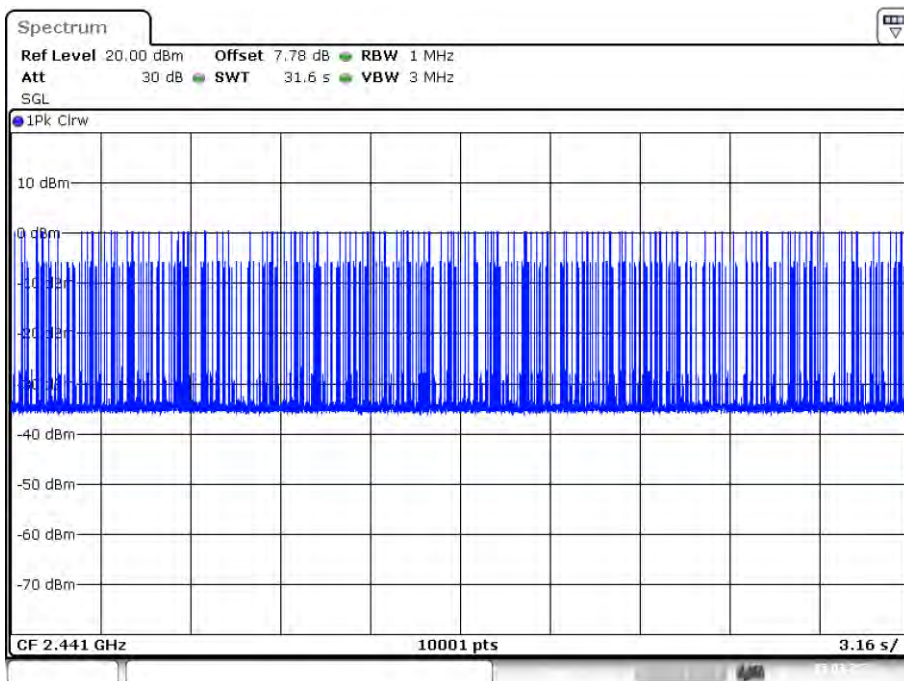

Date: 7.MAR.2022 13:15:35

Dwell NVNT 2-DH5 2441MHz Ant1 One Burst

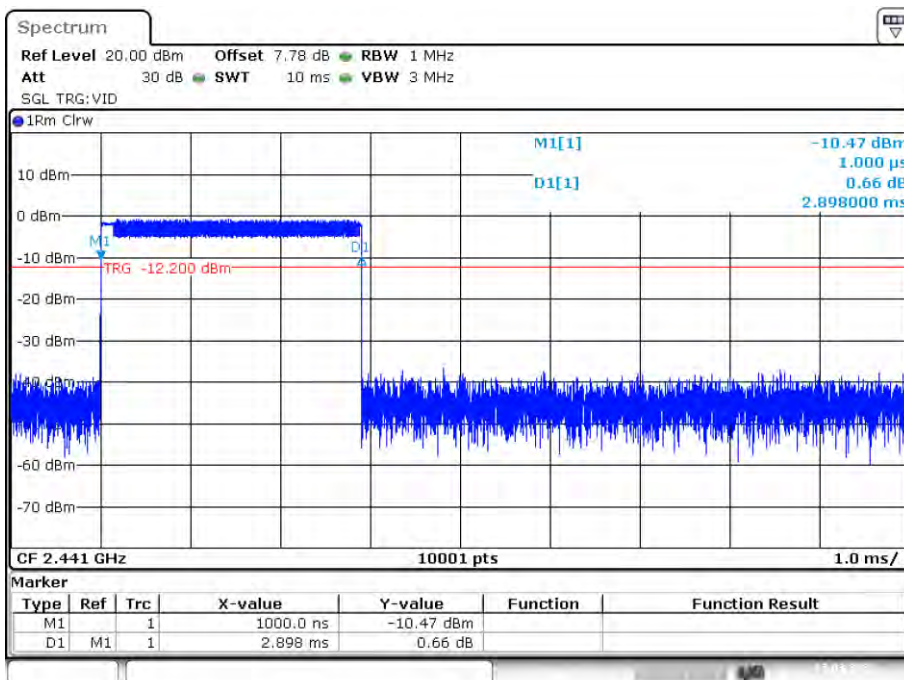

Date: 7.MAR.2022 13:16:15

Dwell NVNT 2-DH5 2441MHz Ant1 Accumulated

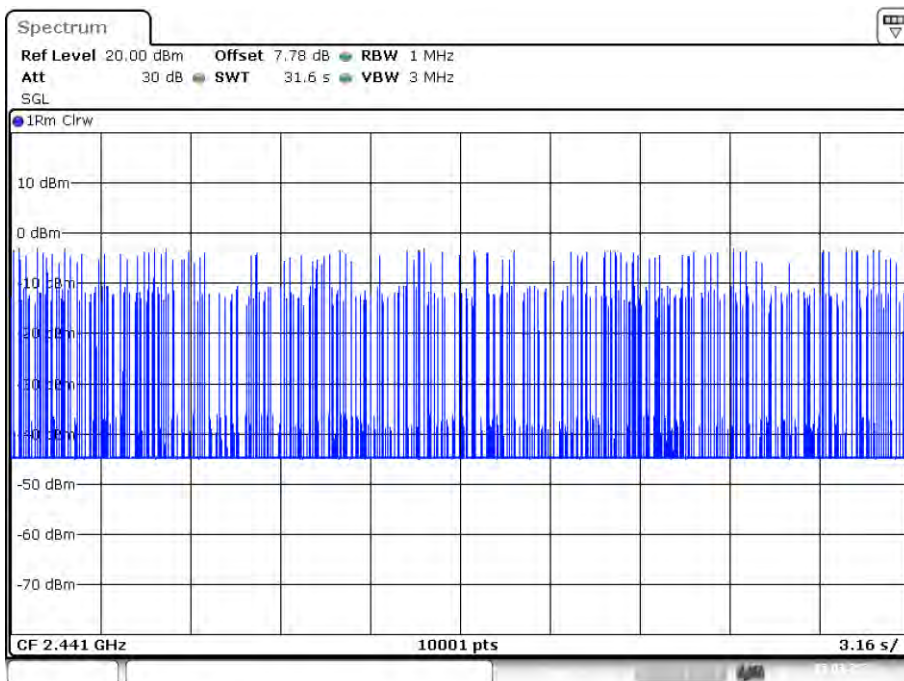

Date: 7.MAR.2022 13:16:50

Dwell NVNT 3-DH1 2402MHz Ant1 One Burst

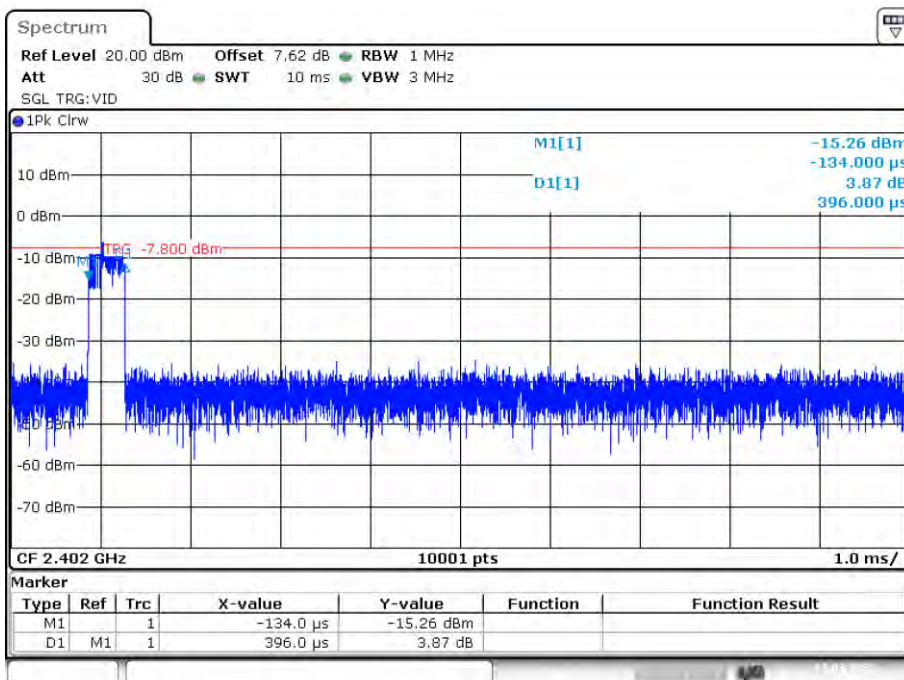

Date: 7.MAR.2022 13:17:23

Dwell NVNT 3-DH1 2441MHz Ant1 Accumulated

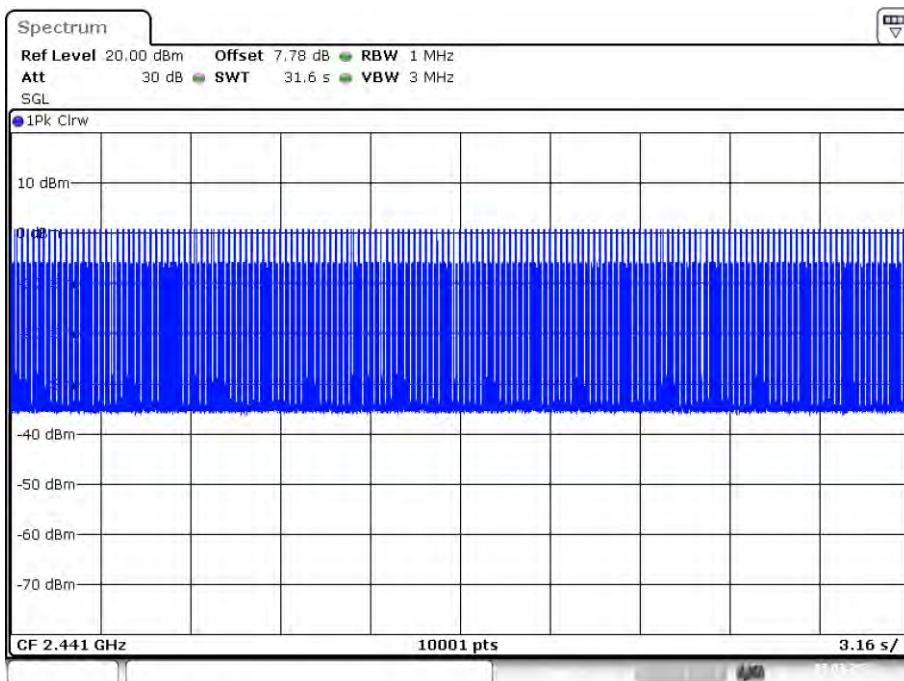

Date: 7.MAR.2022 13:25:06

Dwell NVNT 3-DH1 2480MHz Ant1 One Burst

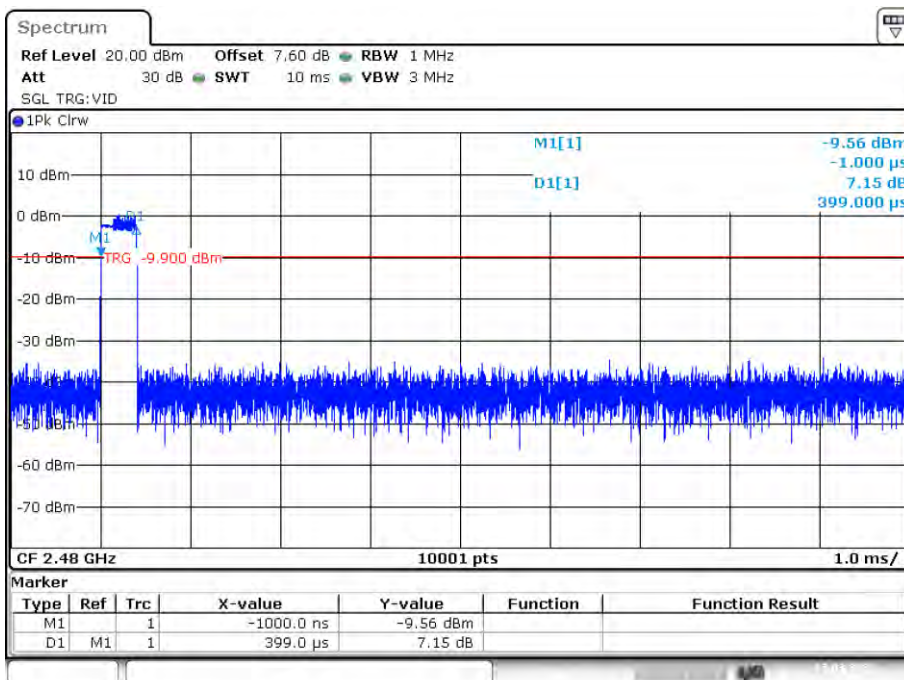

Date: 7.MAR.2022 13:25:22

Dwell NVNT 3-DH5 2441MHz Ant1 Accumulated

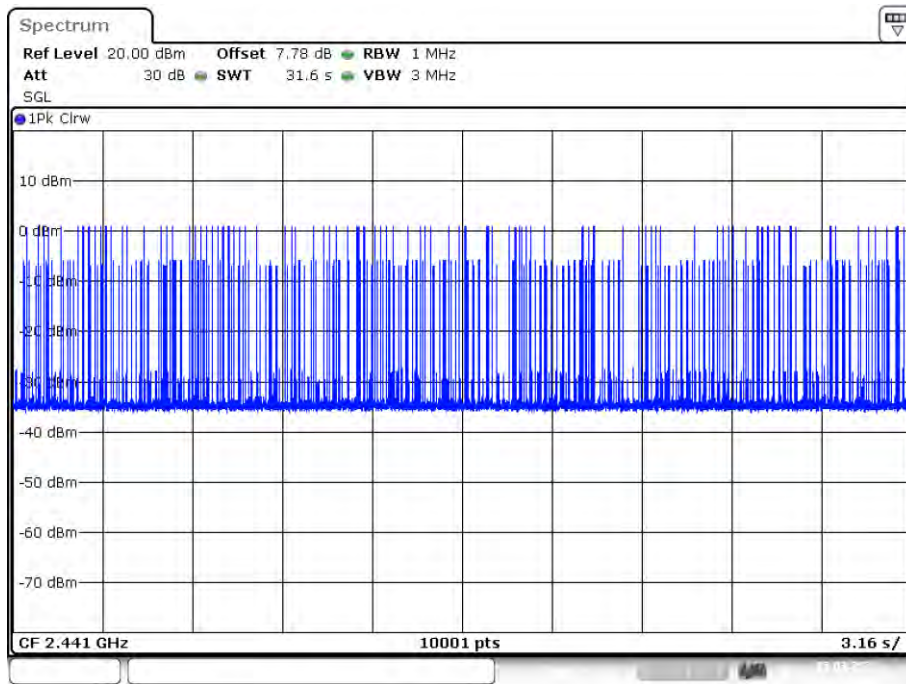

Date: 7.MAR.2022 13:29:14

8. Radiated Emissions

8.1.Limit

All the emissions appearing within 15.205 restricted frequency bands shall not exceed the limits shown in 15.209, all the other emissions shall be at least 20dB below the fundamental emissions, or comply with 15.209 limits.

15.205 Restricted frequency band

MHz	MHz	MHz	GHz
0.090 - 0.110	16.42 - 16.423	399.9 - 410	4.5 - 5.15
¹ 0.495 - 0.505	16.69475 - 16.69525	608 - 614	5.35 - 5.46
2.1735 - 2.1905	16.80425 - 16.80475	960 - 1240	7.25 - 7.75
4.125 - 4.128	25.5 - 25.67	1300 - 1427	8.025 - 8.5
4.17725 - 4.17775	37.5 - 38.25	1435 - 1626.5	9.0 - 9.2
4.20725 - 4.20775	73 - 74.6	1645.5 - 1646.5	9.3 - 9.5
6.215 - 6.218	74.8 - 75.2	1660 - 1710	10.6 - 12.7
6.26775 - 6.26825	108 - 121.94	1718.8 - 1722.2	13.25 - 13.4
6.31175 - 6.31225	123 - 138	2200 - 2300	14.47 - 14.5
8.291 - 8.294	149.9 - 150.05	2310 - 2390	15.35 - 16.2
8.362 - 8.366	156.52475 - 156.52525	2483.5 - 2500	17.7 - 21.4
8.37625 - 8.38675	156.7 - 156.9	2690 - 2900	22.01 - 23.12
8.41425 - 8.41475	162.0125 - 167.17	3260 - 3267	23.6 - 24.0
12.29 - 12.293	167.72 - 173.2	3332 - 3339	31.2 - 31.8
12.51975 - 12.52025	240 - 285	3345.8 - 3358	36.43 - 36.5
12.57675 - 12.57725	322 - 335.4	3600 - 4400	(²)

15.209 Limit

FREQUENCY MHz	DISTANCE Meters	FIELD STRENGTHS LIMIT	
		μV/m	dB(μV)/m
0.009-0.490	300	2400/F(KHz)	/
0.490-1.705	30	24000/F(KHz)	/
1.705-30	30	30	29.5
30 ~ 88	3	100	40.0
88 ~ 216	3	150	43.5
216 ~ 960	3	200	46.0
960 ~ 1000	3	500	54.0
Above 1000	3	74.0 dB(μV)/m (Peak) 54.0 dB(μV)/m (Average)	

Note: The peak limit is 20 dB higher than the average limit

8.2. Block Diagram of Test setup

8.2.1 In 3m Anechoic Chamber Test Setup Diagram for below 30MHz

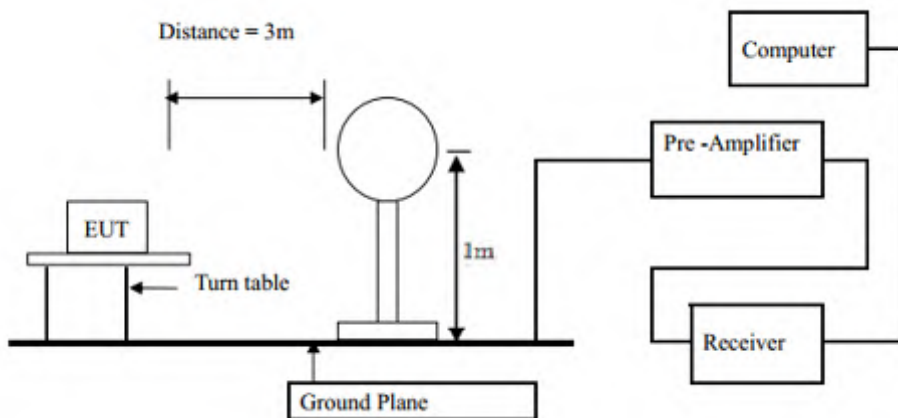

8.2.1 In 3m Anechoic Chamber Test Setup Diagram for below 1GHz

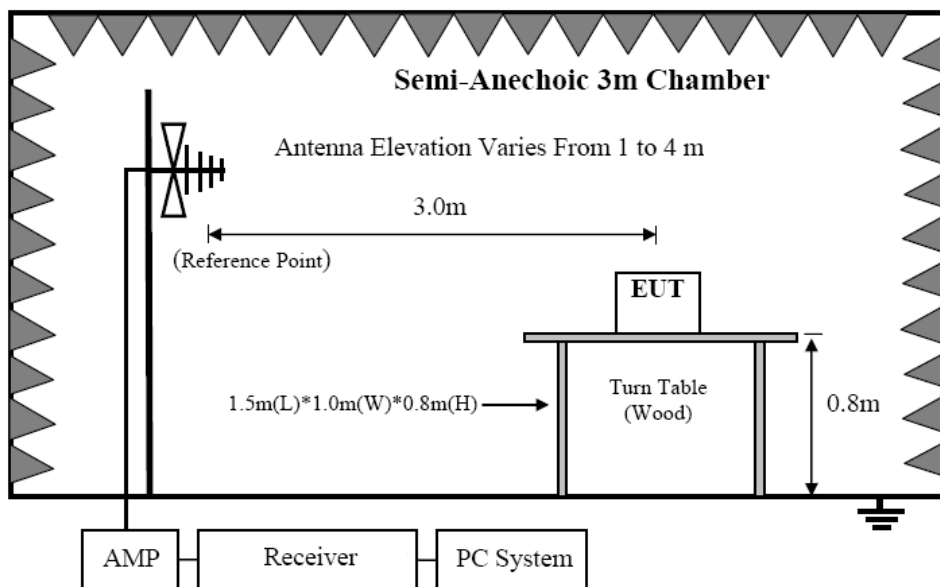

8.2.2 In 3m Anechoic Chamber Test Setup Diagram for frequency above 1GHz

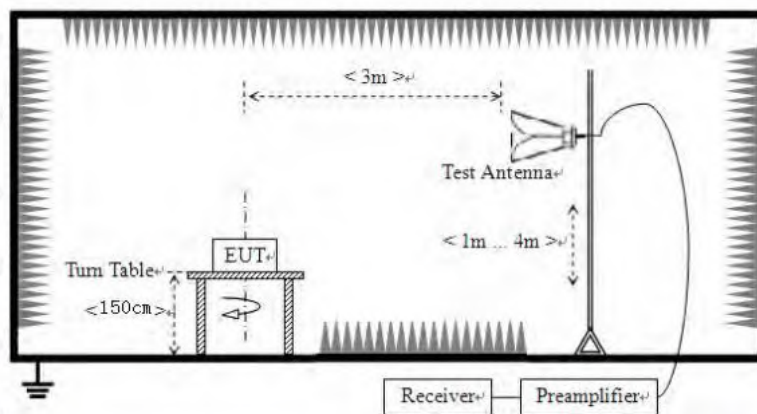

Note: For harmonic emissions test a appropriate high pass filter was inserted in the input port of AMP.

8.3. Test Procedure

- (1) EUT was placed on a non-metallic table, 80 cm above the ground plane inside a semi-anechoic chamber.
- (2) Setup EUT and simulator
- (3) Test antenna was located 3m from the EUT on an adjustable mast. Below pre-scan procedure was first performed in order to find prominent radiated emissions.
 - (a) Change work frequency or channel of device if practicable.
 - (b) Change modulation type of device if practicable.
 - (c) Rotated EUT though three orthogonal axes to determine the attitude of EUT arrangement produces highest emissions
- (4) Spectrum frequency from 9KHz to 25GHz (tenth harmonic of fundamental frequency) was investigated
- (5) For final emissions measurements at each frequency of interest, the EUT were rotated and the antenna height was varied between 1m and 4m in order to maximize the emission. Measurements in both horizontal and vertical polarities were made and the data was recorded. In order to find the maximum emission, the relative positions of equipments and all of the interface cables were changed according to ANSI C63.10 :2013on Radiated Emission test.
- (6) For emissions above 1GHz, both Peak and Average level were measured with Spectrum Analyzer, and the RBW is set at 1MHz, VBW is set at 3MHz for Peak measure; RBW is set at 1MHz, VBW is set at 10Hz for Average measure.

8.4. Test Result

We have scanned from 9kHz to the 10th harmonic of the EUT's highest frequency.
Detailed information please see the following page.

From 9KHz to 30MHz: Conclusion: PASS

Note: The amplitude of spurious emissions which are attenuated by more than 20dB below the permissible value has no need to be reported.

From 30MHz to 1000MHz: Conclusion: PASS

Vertical:

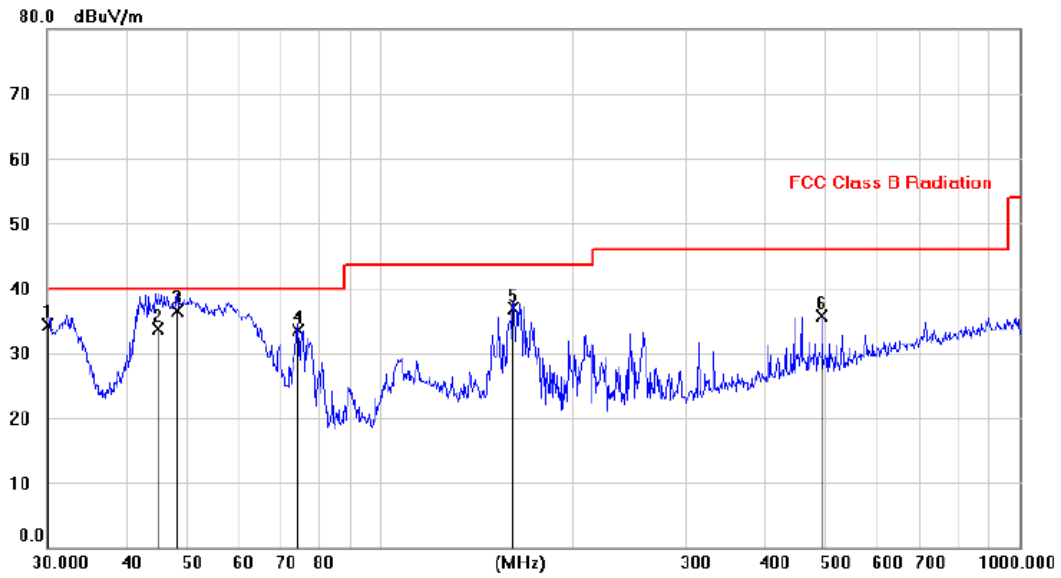

No.	Mk.	Freq.	Reading Level	Correct Factor	Measurement	Limit	Margin	Antenna Height	Table Degree	
		MHz	dBuV	dB	dBuV/m	dBuV/m	dB	cm	degree	Comment
1		30.0035	20.78	13.52	34.30	40.00	-5.70			QP
2		44.8115	19.61	14.13	33.74	40.00	-6.26			QP
3	*	48.0053	22.52	14.08	36.60	40.00	-3.40			QP
4		74.1698	22.73	10.76	33.49	40.00	-6.51			QP
5		161.4176	21.94	14.90	36.84	43.50	-6.66			QP
6		492.0081	17.55	18.11	35.66	46.00	-10.34			peak

Note:1. *:Maximum data; x:Over limit; !:over margin.

2.Measurement=Reading Level+Correct Factor; Correct Factor=Antenna Factor+Cable Loss.

Horizontal:

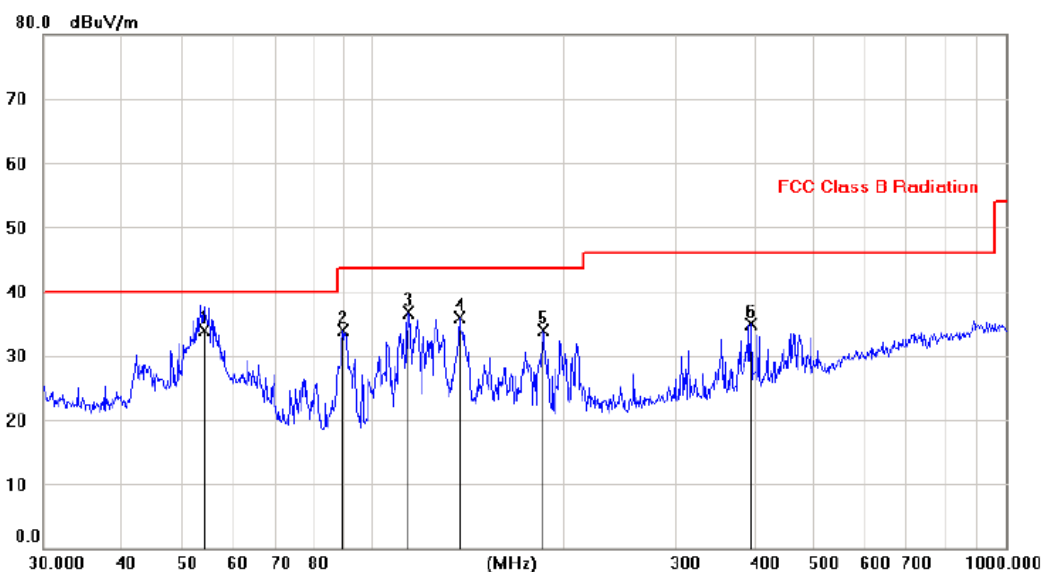

No.	Mk.	Freq.	Reading Level	Correct Factor	Measurement	Limit	Margin	Antenna Height	Table Degree	
		MHz	dBuV	dB	dBuV/m	dBuV/m	dB	cm	degree	Comment
1	*	53.9819	20.14	13.72	33.86	40.00	-6.14	QP		
2		89.5586	23.83	10.04	33.87	43.50	-9.63	peak		
3		113.5549	24.45	12.26	36.71	43.50	-6.79	peak		
4		136.8912	21.89	14.09	35.98	43.50	-7.52	peak		
5		185.6580	21.99	12.00	33.99	43.50	-9.51	peak		
6		396.0100	18.78	16.18	34.96	46.00	-11.04	peak		

Note:1. *:Maximum data; x:Over limit; !:over margin.

2.Measurement=Reading Level+Correct Factor; Correct Factor=Antenna Factor+Cable Loss.

Remark: All modes have been tested, and only worst data of GFSK mode, Channel 2441MHz (AC 120V/60Hz) was listed in this report.

From 1G-25GHz

Test Mode: GFSK TX Low									
Freq (MHz)	Read Level (dBuV/m)	Polar (H/V)	Antenna Factor (dB/m)	Cable loss(dB)	Amp Factor (dB)	Result (dBuV/m)	Limit (dBuV/m)	Margin (dB)	Remark
4804	47.05	V	34.77	10.18	35.21	56.78	74	-17.22	PK
4804	37.30	V	34.49	10.18	35.40	46.57	54	-7.43	AV
7206	/	/	/	/	/	/	/	/	/
9608	/	/	/	/	/	/	/	/	/
4804	48.78	H	34.59	10.18	35.75	57.79	74	-16.21	PK
4804	35.40	H	34.48	10.18	34.79	45.27	54	-8.73	AV
7206	/	/	/	/	/	/	/	/	/
9608	/	/	/	/	/	/	/	/	/
Test Mode: GFSK TX Mid									
4882	45.67	V	34.54	10.2	35.40	55.01	74	-18.99	PK
4882	35.94	V	34.59	10.2	34.96	45.77	54	-8.23	AV
7323	/	/	/	/	/	/	/	/	/
9764	/	/	/	/	/	/	/	/	/
4882	44.03	H	34.78	10.2	35.35	53.66	74	-20.34	PK
4882	35.24	H	34.73	10.2	35.39	44.78	54	-9.22	AV
7323	/	/	/	/	/	/	/	/	/
9764	/	/	/	/	/	/	/	/	/
Test Mode: GFSK TX High									
4960	44.26	V	34.38	10.22	35.57	53.29	74	-20.71	PK
4960	35.93	V	34.65	10.22	35.32	45.48	54	-8.52	AV
7440	/	/	/	/	/	/	/	/	/
9920	/	/	/	/	/	/	/	/	/
4960	44.00	H	34.81	10.22	35.14	53.90	74	-20.10	PK
4960	34.40	H	34.80	10.22	34.99	44.43	54	-9.57	AV
7440	/	/	/	/	/	/	/	/	/
9920	/	/	/	/	/	/	/	/	/
Note:									
1, Result = Read level + Antenna factor + cable loss-Amp factor									
2, All the other emissions not reported were too low to read and deemed to comply with FCC limit.									

From 1G-25GHz

Test Mode: $\pi/4$ DQPSK TX Low									
Freq (MHz)	Read Level (dBuV/m)	Polar (H/V)	Antenna Factor (dB/m)	Cable loss(dB)	Amp Factor (dB)	Result (dBuV/m)	Limit (dBuV/m)	Margin (dB)	Remark
4804	47.21	V	34.93	10.18	35.41	56.91	74	-17.09	PK
4804	38.89	V	34.26	10.18	35.42	47.91	54	-6.09	AV
7206	/	/	/	/	/	/	/	/	/
9608	/	/	/	/	/	/	/	/	/
4804	45.44	H	34.75	10.18	35.54	54.83	74	-19.17	PK
4804	36.18	H	34.77	10.18	34.82	46.31	54	-7.69	AV
7206	/	/	/	/	/	/	/	/	/
9608	/	/	/	/	/	/	/	/	/
Test Mode: $\pi/4$ DQPSK TX Mid									
4882	42.19	V	34.52	10.2	34.95	51.96	74	-22.04	PK
4882	37.44	V	34.24	10.2	35.54	46.34	54	-7.66	AV
7323	/	/	/	/	/	/	/	/	/
9764	/	/	/	/	/	/	/	/	/
4882	44.04	H	34.51	10.2	35.23	53.52	74	-20.48	PK
4882	34.65	H	34.60	10.2	35.73	43.72	54	-10.28	AV
7323	/	/	/	/	/	/	/	/	/
9764	/	/	/	/	/	/	/	/	/
Test Mode: $\pi/4$ DQPSK TX High									
4960	47.29	V	34.52	10.22	34.87	57.16	74	-16.84	PK
4960	34.46	V	34.48	10.22	35.60	43.56	54	-10.44	AV
7440	/	/	/	/	/	/	/	/	/
9920	/	/	/	/	/	/	/	/	/
4960	44.54	H	34.57	10.22	35.16	54.16	74	-19.84	PK
4960	36.02	H	34.29	10.22	35.63	44.91	54	-9.09	AV
7440	/	/	/	/	/	/	/	/	/
9920	/	/	/	/	/	/	/	/	/
Note:									
1, Result = Read level + Antenna factor + cable loss-Amp factor									
2, All the other emissions not reported were too low to read and deemed to comply with FCC limit.									

From 1G-25GHz

Test Mode: 8- DQPSK TX Low									
Freq (MHz)	Read Level (dBuV/m)	Polar (H/V)	Antenna Factor (dB/m)	Cable loss(dB)	Amp Factor (dB)	Result (dBuV/m)	Limit (dBuV/m)	Margin (dB)	Remark
4804	46.27	V	34.75	10.18	35.11	56.09	74	-17.91	PK
4804	38.62	V	34.43	10.18	35.48	47.75	54	-6.25	AV
7206	/	/	/	/	/	/	/	/	/
9608	/	/	/	/	/	/	/	/	/
4804	46.53	H	34.67	10.18	35.10	56.29	74	-17.71	PK
4804	39.07	H	34.29	10.18	35.58	47.95	54	-6.05	AV
7206	/	/	/	/	/	/	/	/	/
9608	/	/	/	/	/	/	/	/	/
Test Mode: 8- DQPSK TX Mid									
4882	43.84	V	34.52	10.2	35.61	52.96	74	-21.04	PK
4882	35.79	V	34.69	10.2	34.95	45.73	54	-8.27	AV
7323	/	/	/	/	/	/	/	/	/
9764	/	/	/	/	/	/	/	/	/
4882	44.61	H	34.76	10.2	35.05	54.52	74	-19.48	PK
4882	35.23	H	34.38	10.2	35.12	44.69	54	-9.31	AV
7323	/	/	/	/	/	/	/	/	/
9764	/	/	/	/	/	/	/	/	/
Test Mode: 8- DQPSK TX High									
4960	45.84	V	34.60	10.22	35.17	55.50	74	-18.50	PK
4960	34.93	V	34.77	10.22	35.52	44.40	54	-9.60	AV
7440	/	/	/	/	/	/	/	/	/
9920	/	/	/	/	/	/	/	/	/
4960	43.35	H	34.31	10.22	35.67	52.21	74	-21.79	PK
4960	35.30	H	34.77	10.22	35.36	44.92	54	-9.08	AV
7440	/	/	/	/	/	/	/	/	/
9920	/	/	/	/	/	/	/	/	/
Note:									
1, Result = Read level + Antenna factor + cable loss-Amp factor									
2, All the other emissions not reported were too low to read and deemed to comply with FCC limit.									

Conducted RF Spurious Emission

Condition	Mode	Frequency (MHz)	Antenna	Max Value (dBc)	Limit (dBc)	Verdict
NVNT	1-DH1	2402	Ant 1	-37.57	-20	Pass
NVNT	1-DH1	2441	Ant 1	-35.24	-20	Pass
NVNT	1-DH1	2480	Ant 1	-35.21	-20	Pass
NVNT	2-DH1	2402	Ant 1	-37.04	-20	Pass
NVNT	2-DH1	2441	Ant 1	-35.54	-20	Pass
NVNT	2-DH1	2480	Ant 1	-35.18	-20	Pass
NVNT	3-DH1	2402	Ant 1	-37.75	-20	Pass
NVNT	3-DH1	2441	Ant 1	-35.35	-20	Pass
NVNT	3-DH1	2480	Ant 1	-35.27	-20	Pass

Tx. Spurious NVNT 1-DH1 2402MHz Ant1 Emission

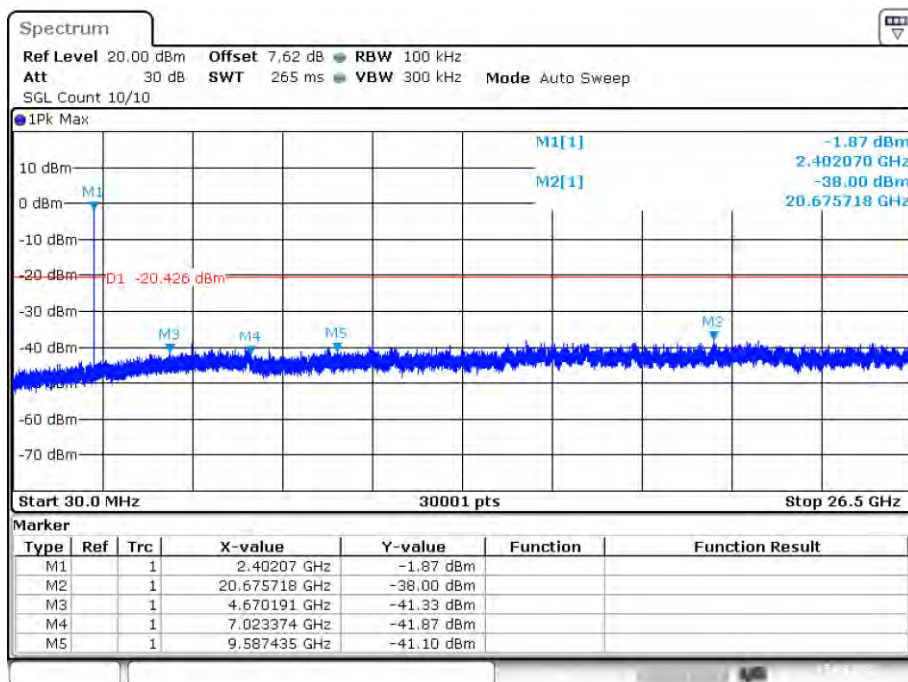

Date: 7.MAR.2022 11:18:46

Tx. Spurious NVNT 1-DH1 2441MHz Ant1 Emission

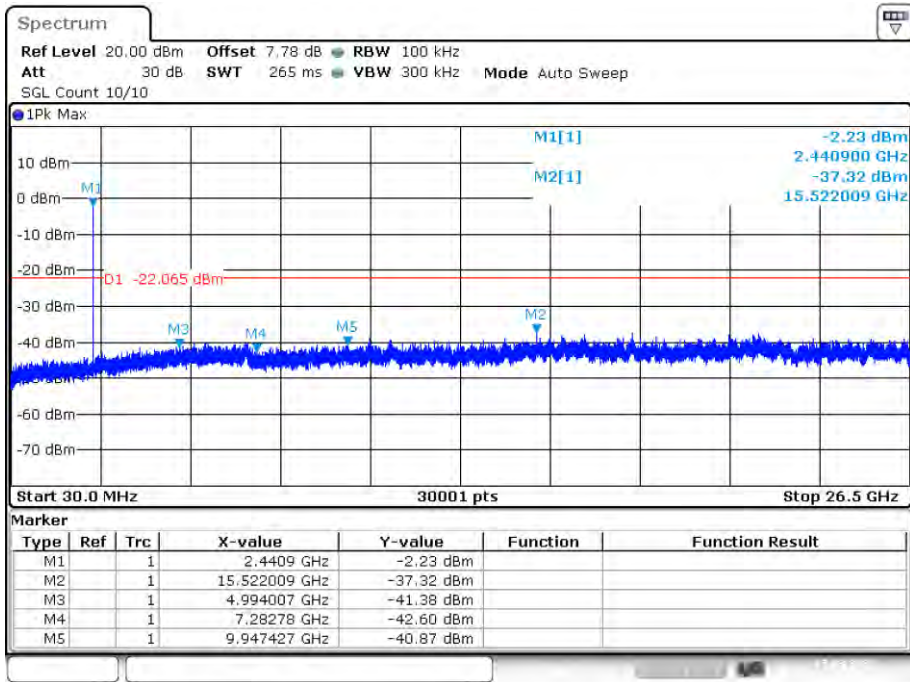

Date: 7.MAR.2022 11:20:21

Tx. Spurious NVNT 1-DH1 2480MHz Ant1 Emission

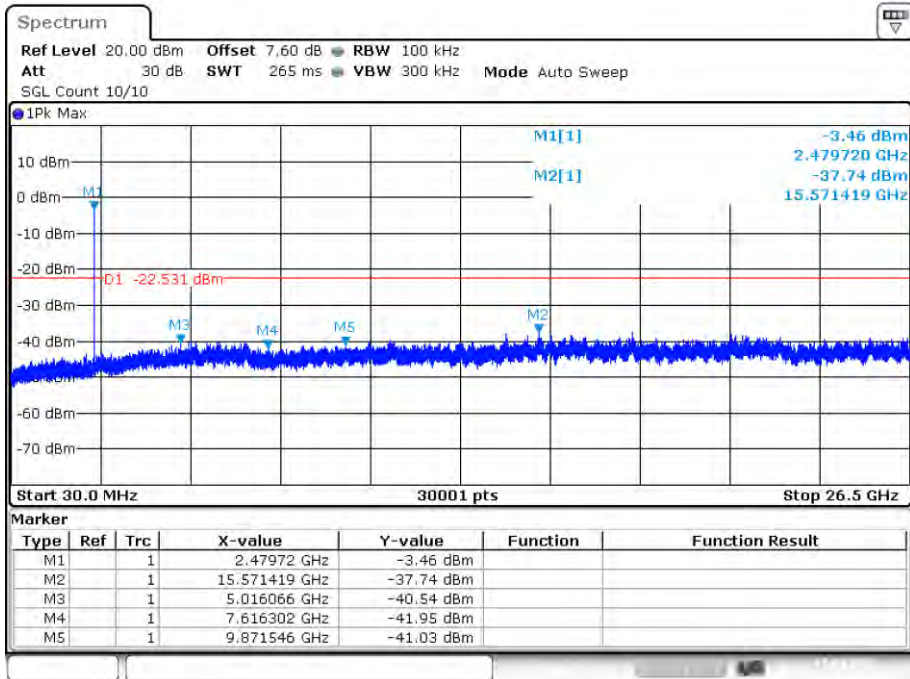

Date: 7.MAR.2022 11:21:54

Tx. Spurious NVNT 2-DH1 2402MHz Ant1 Emission

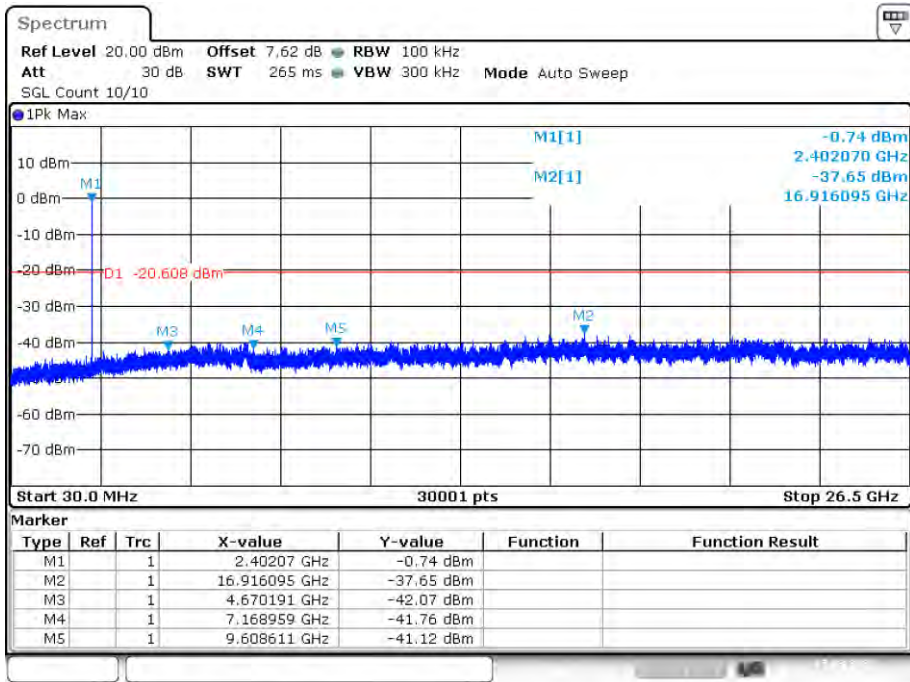

Date: 7.MAR.2022 11:38:18

Tx. Spurious NVNT 2-DH1 2441MHz Ant1 Emission

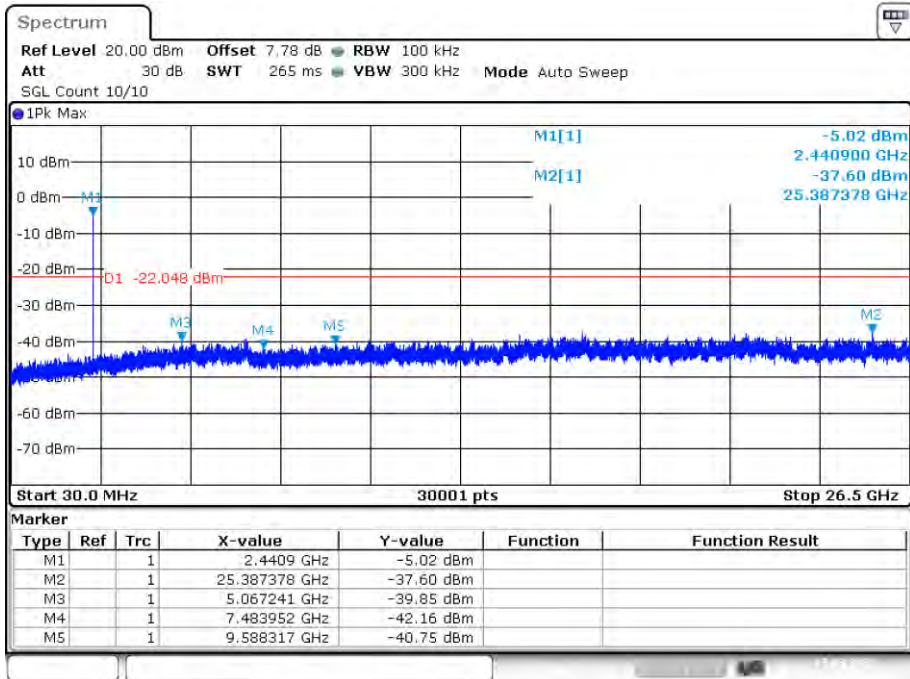

Date: 7.MAR.2022 11:29:12

Tx. Spurious NVNT 2-DH1 2480MHz Ant1 Emission

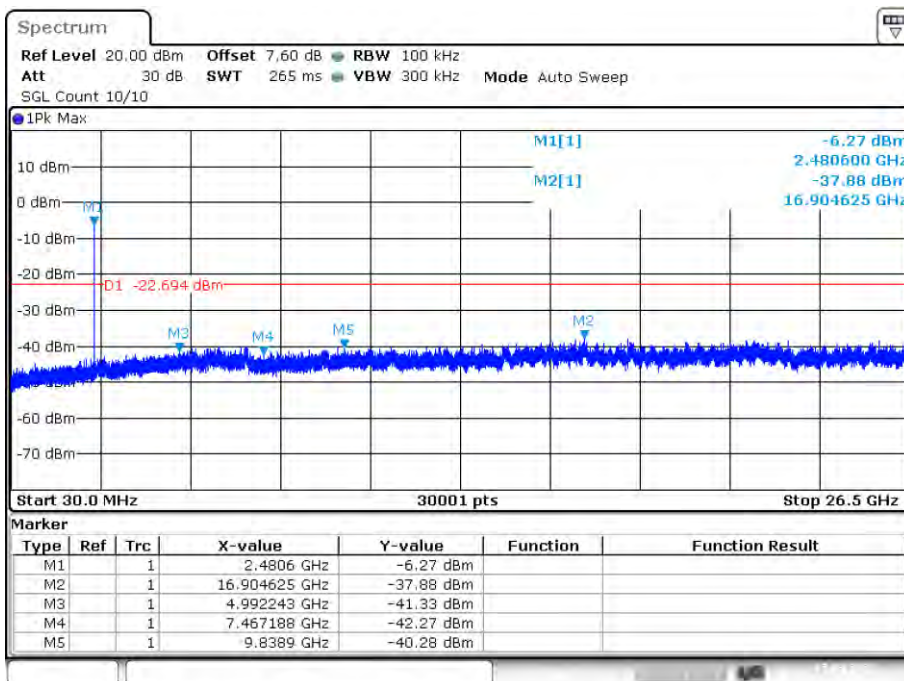

Date: 7.MAR.2022 11:36:28

Tx. Spurious NVNT 3-DH1 2402MHz Ant1 Emission

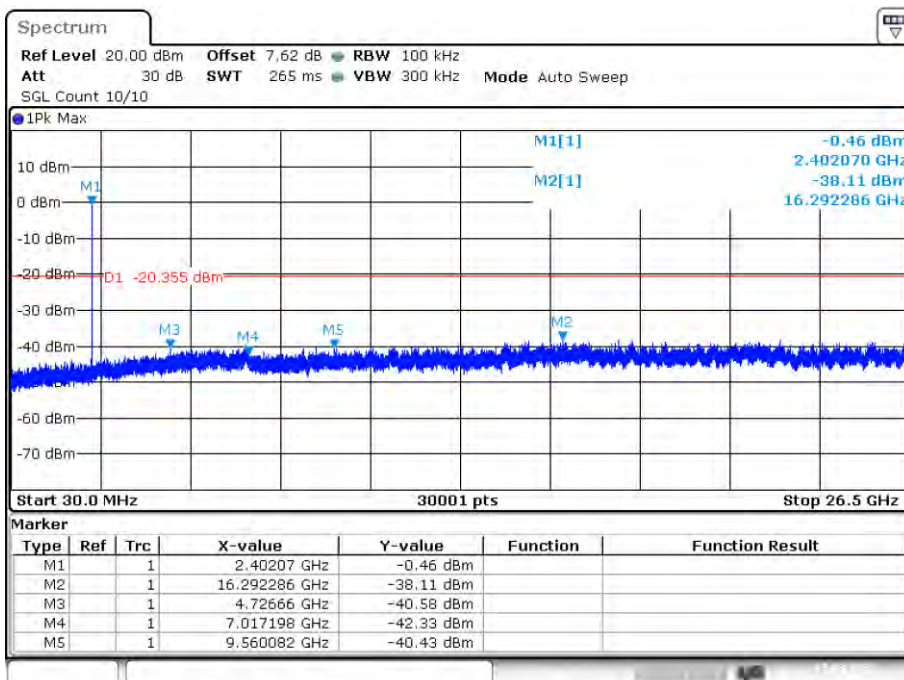

Date: 7.MAR.2022 11:40:30

Tx. Spurious NVNT 3-DH1 2441MHz Ant1 Emission

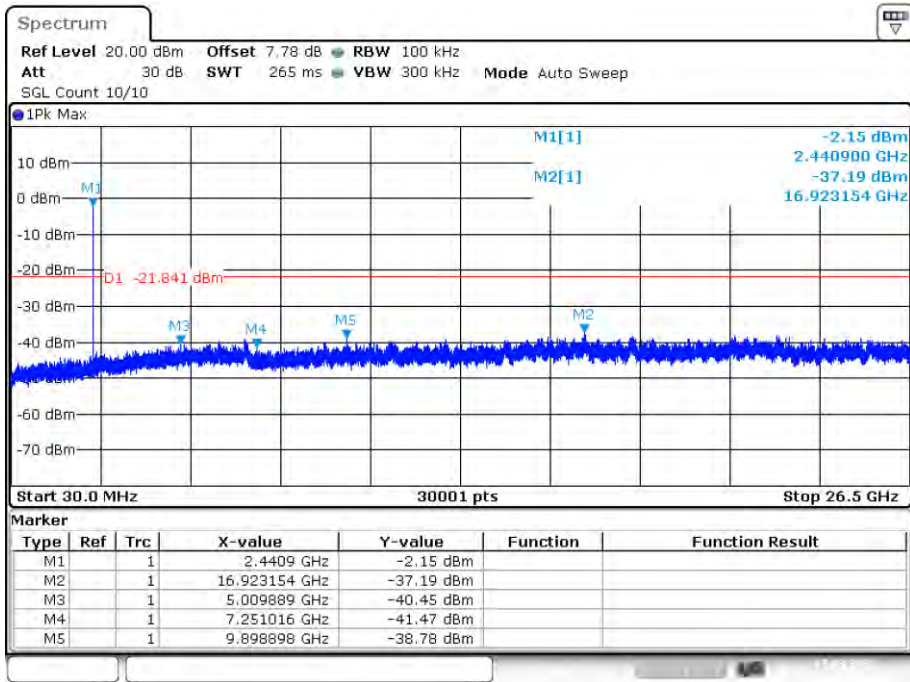

Date: 7.MAR.2022 11:32:08

Tx. Spurious NVNT 3-DH1 2480MHz Ant1 Emission

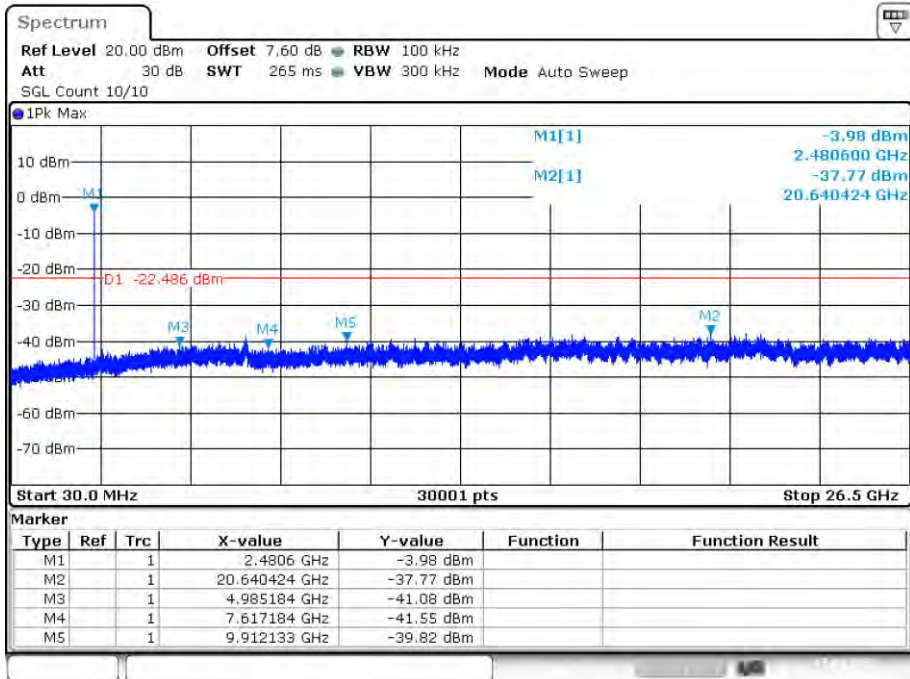

Date: 7.MAR.2022 11:34:54

9. Band Edge Compliance

9.1. Block Diagram of Test Setup

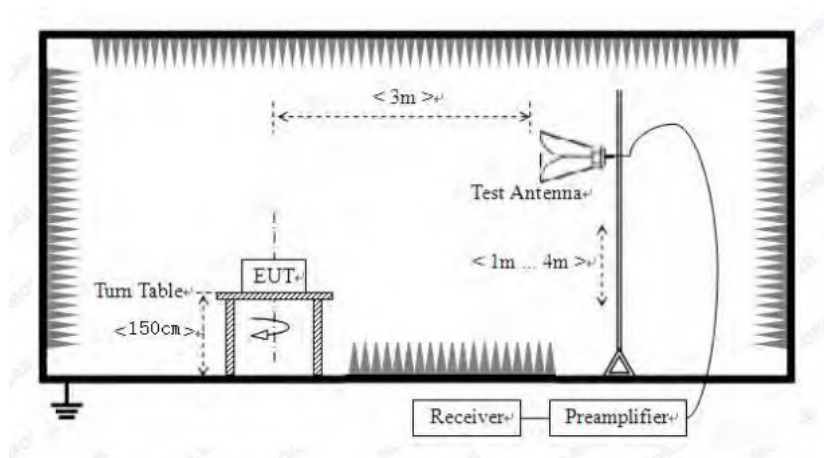

9.2. Limit

All the lower and upper band-edges emissions appearing within restricted frequency bands shall not exceed the limits shown in FCC part 15.209 and RSS-GEN, all the other emissions outside operation shall be at least 20dB below the fundamental emissions, or comply with FCC part 15.209 and RSS-GEN limits.

9.3. Test Procedure

Refer to ANSI C 63.10, Clause 6.10.

All restriction band and non- restriction band have been tested, only worse case is reported.

9.4. Test Result

PASS. (See below detailed test data)

Radiated Method:

Test Mode: GFSK-Low

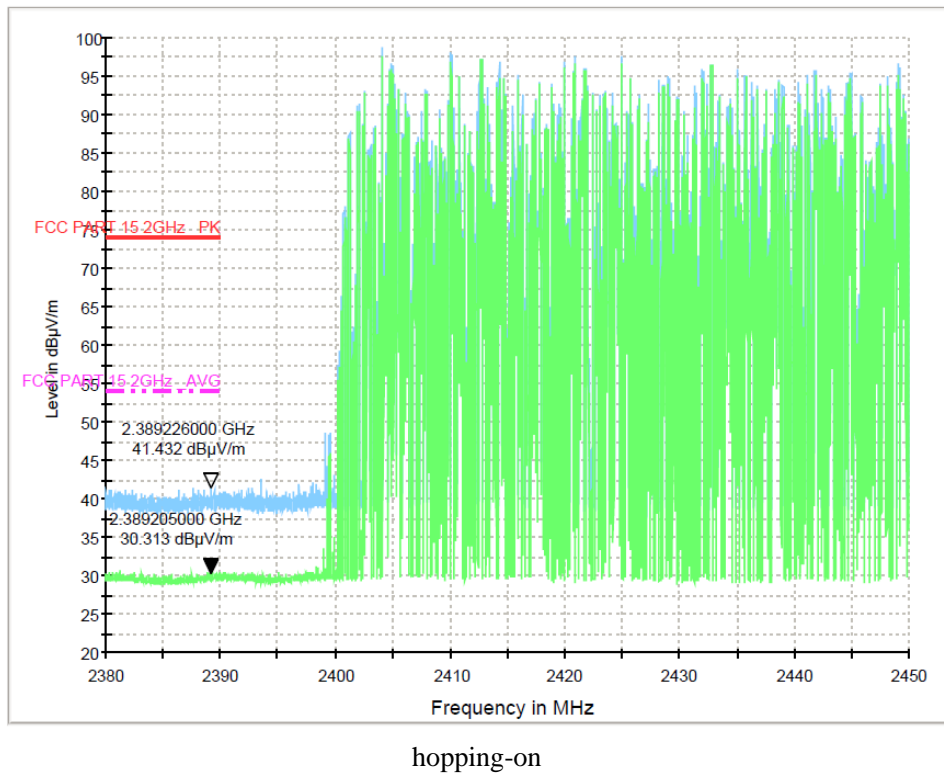
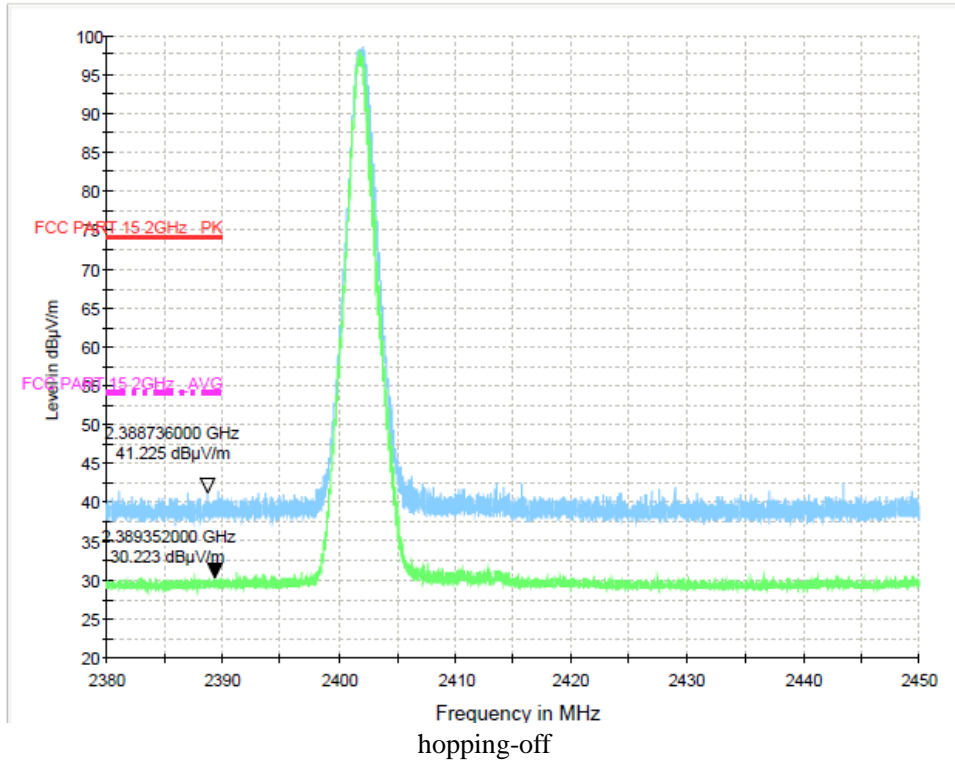

Test Mode: GFSK-High

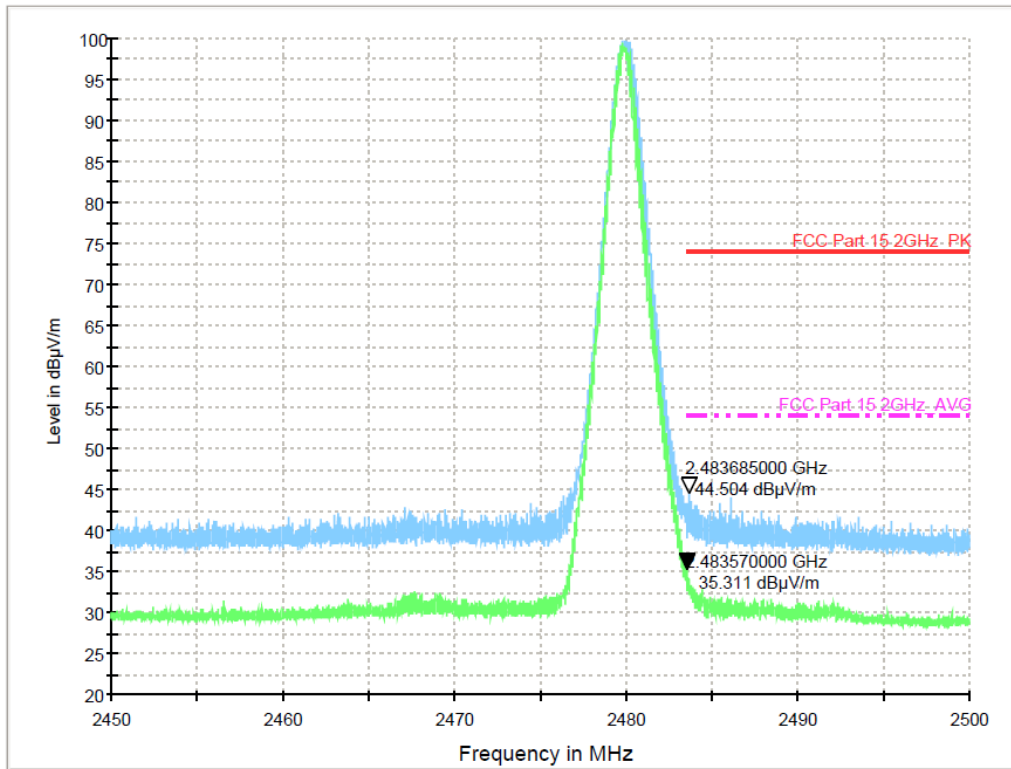

hopping-off

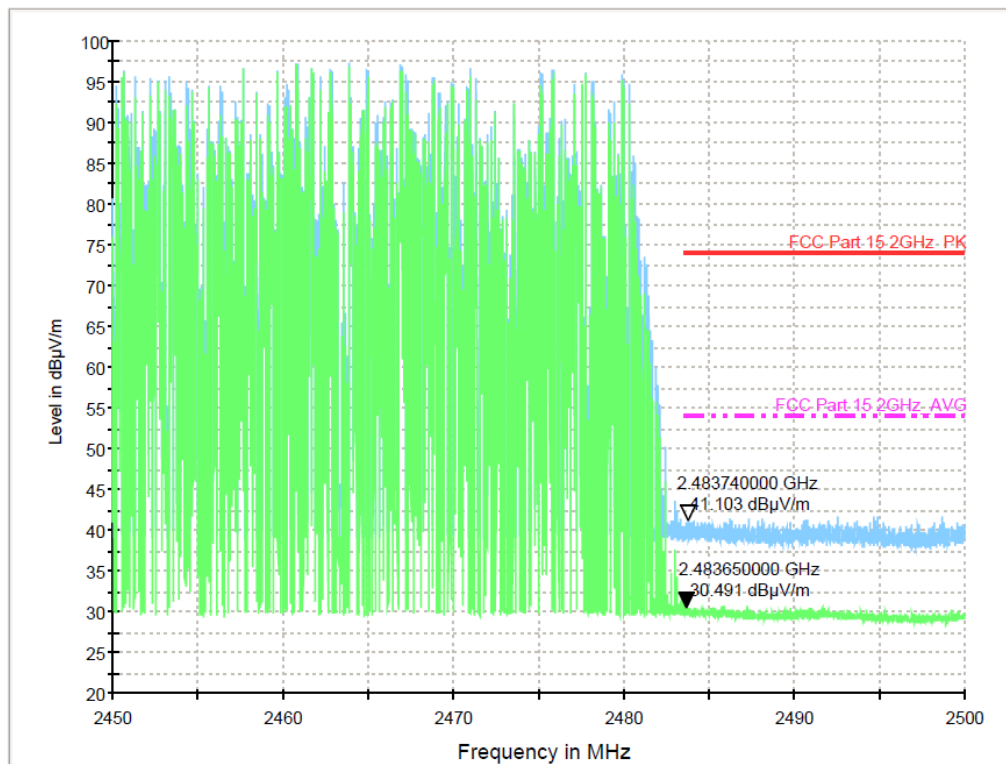

hopping-on

Test Mode: $\pi/4$ DQPSK-Low

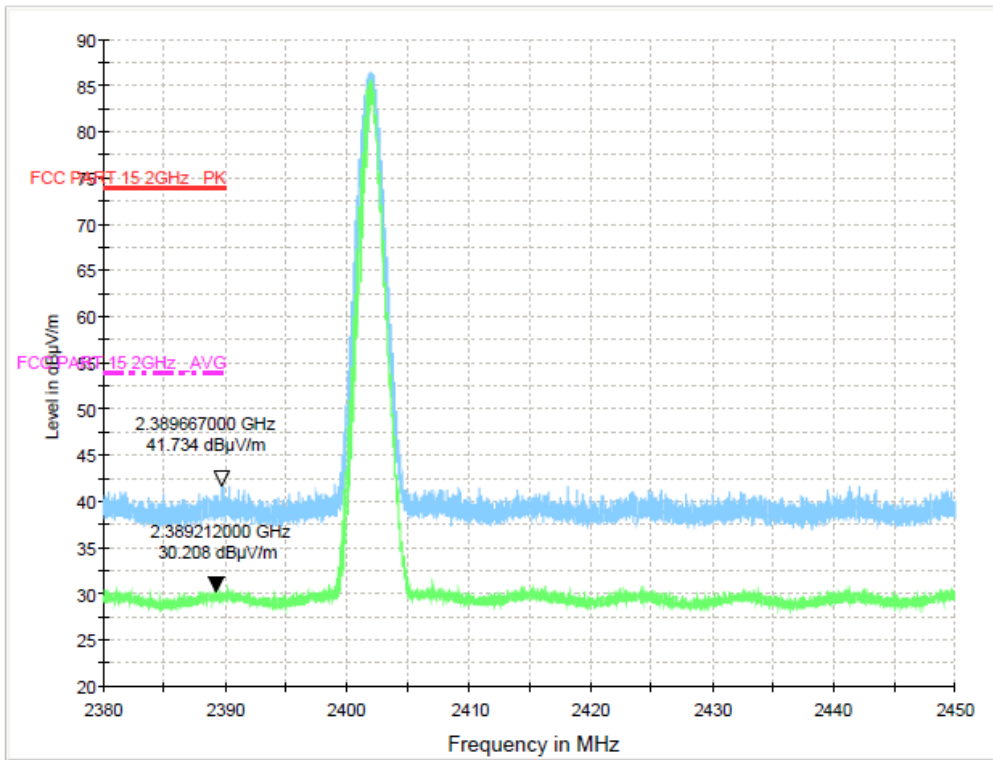

hopping-off

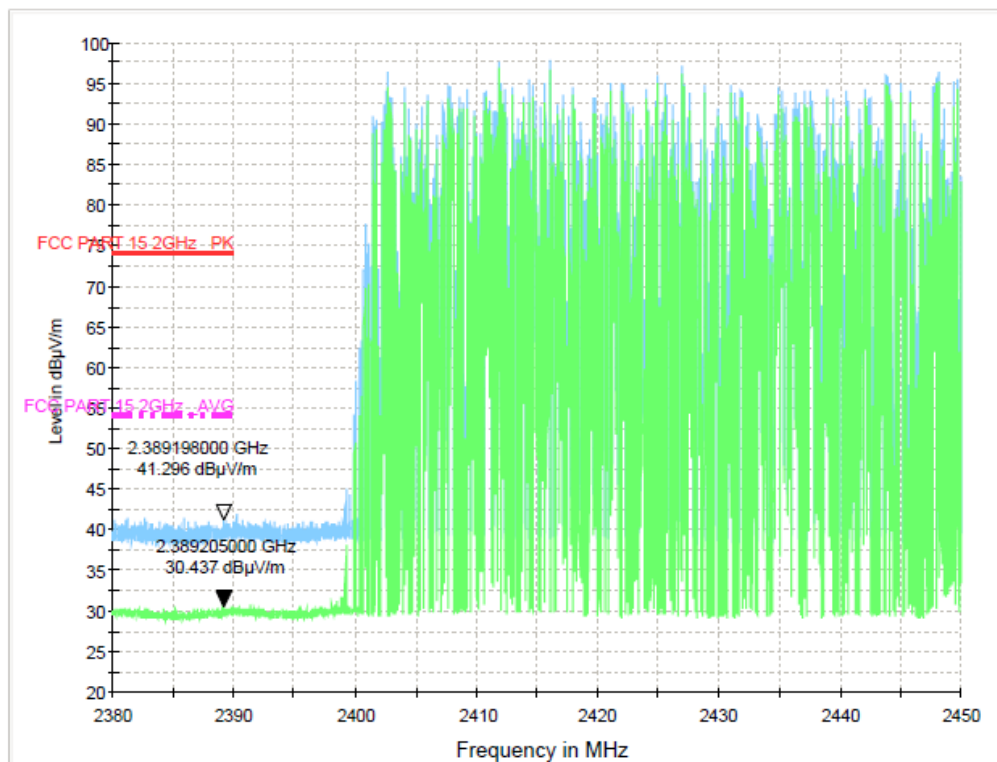

hopping-on

Test Mode: $\pi/4$ DQPSK-High

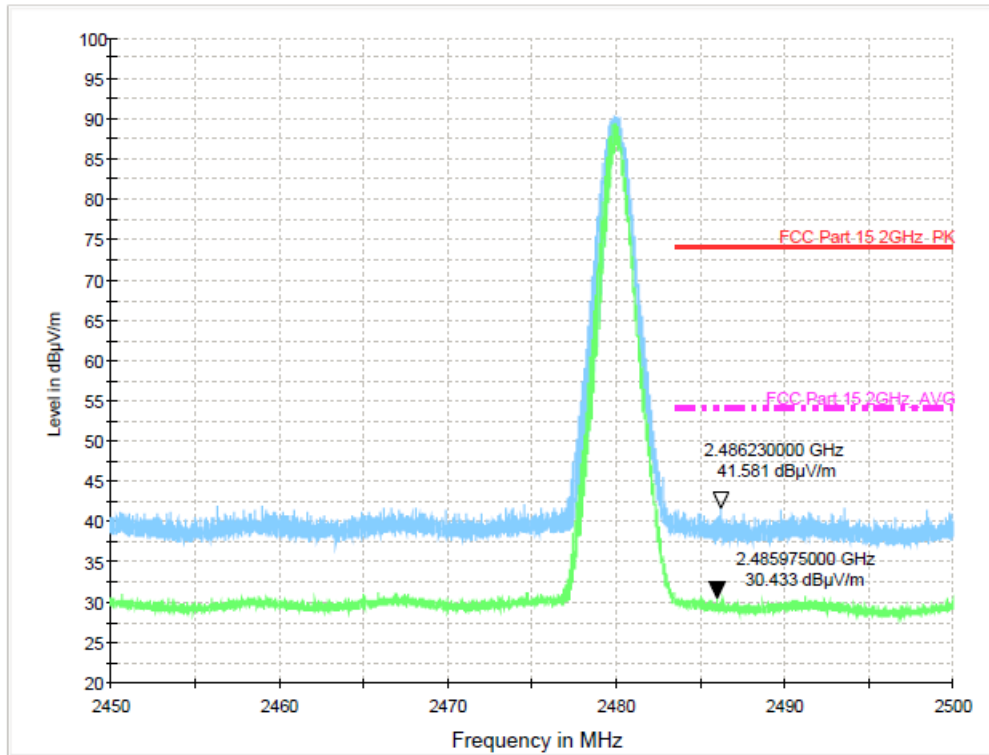

hopping-off

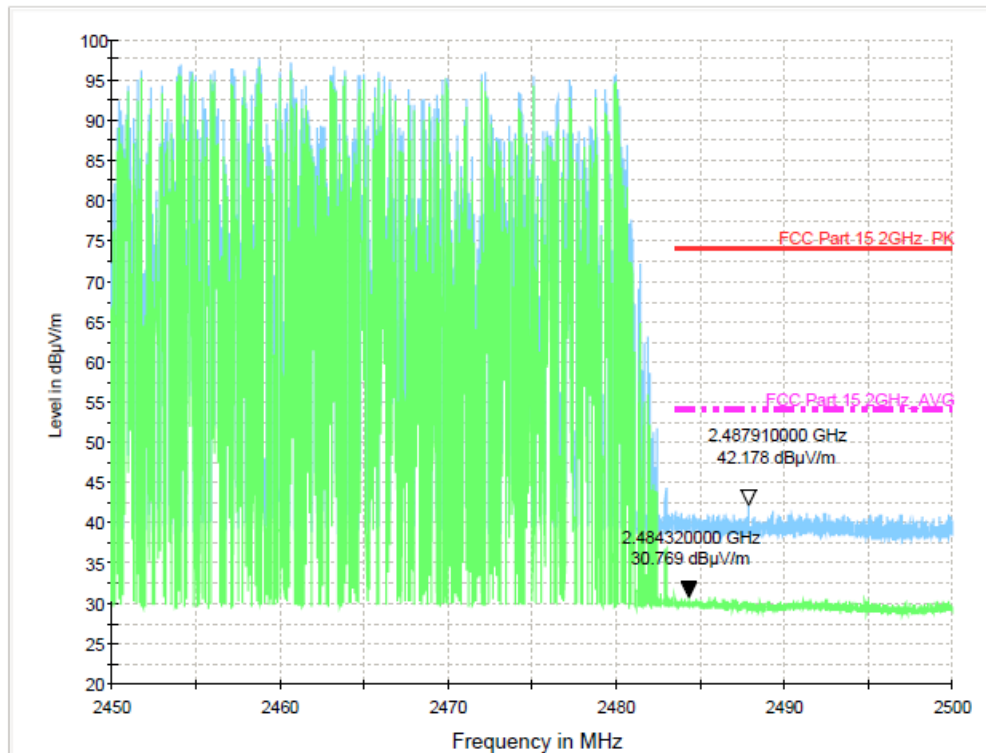

hopping-on

Test Mode: 8DPSK-Low

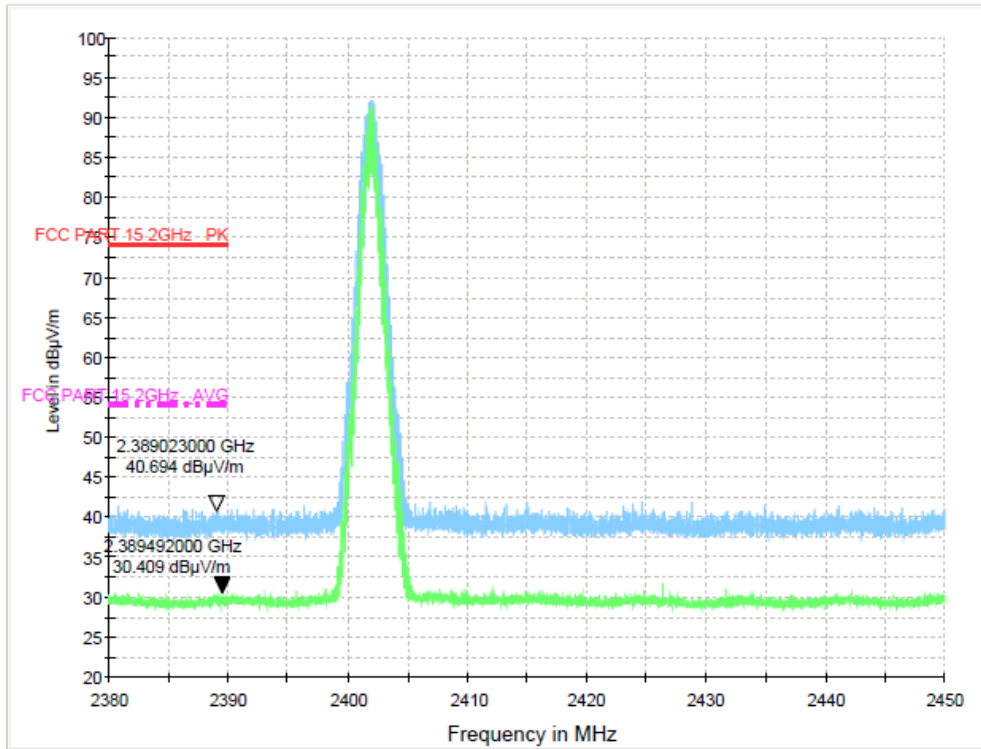

hopping-off

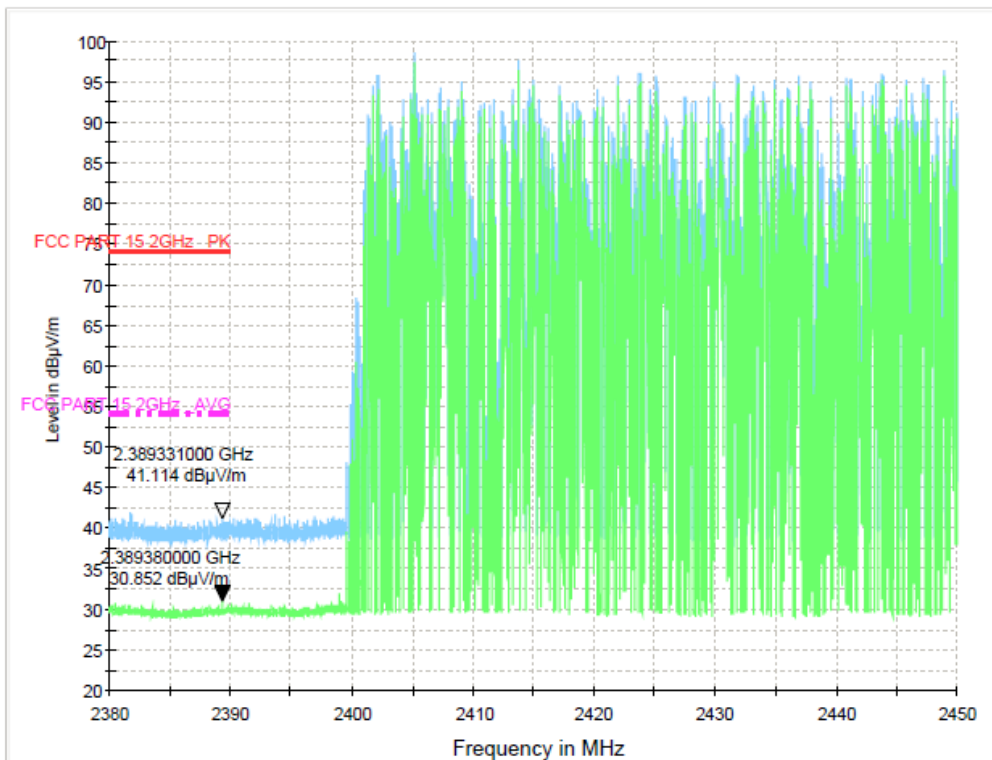

hopping-on

8DPSK-High

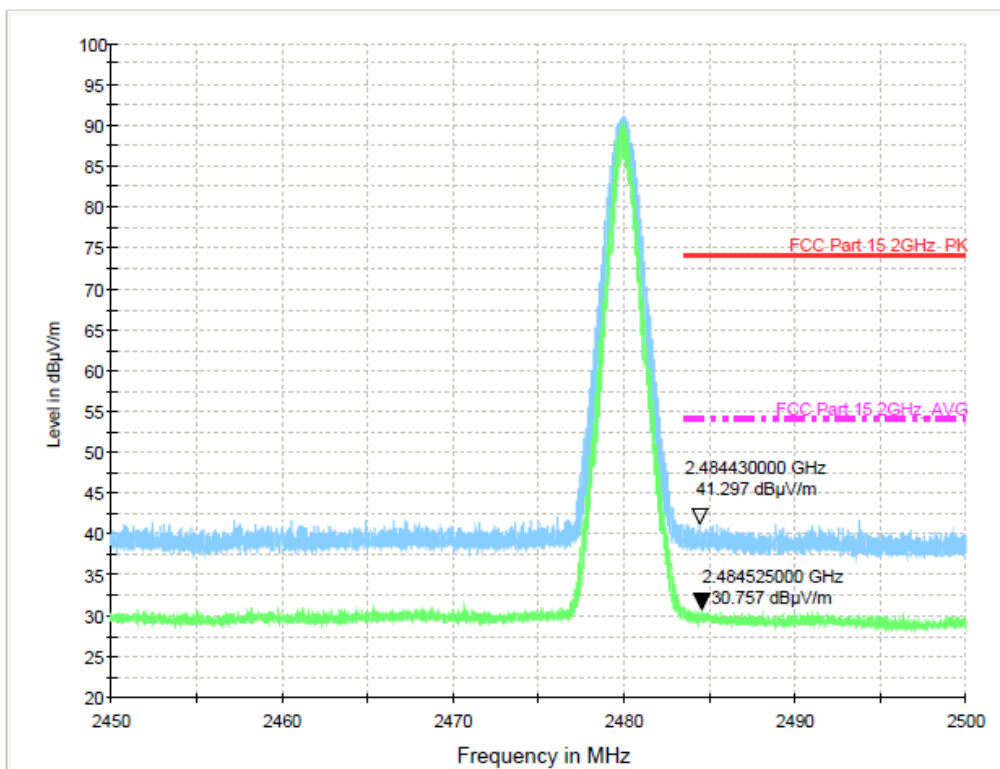

hopping-off

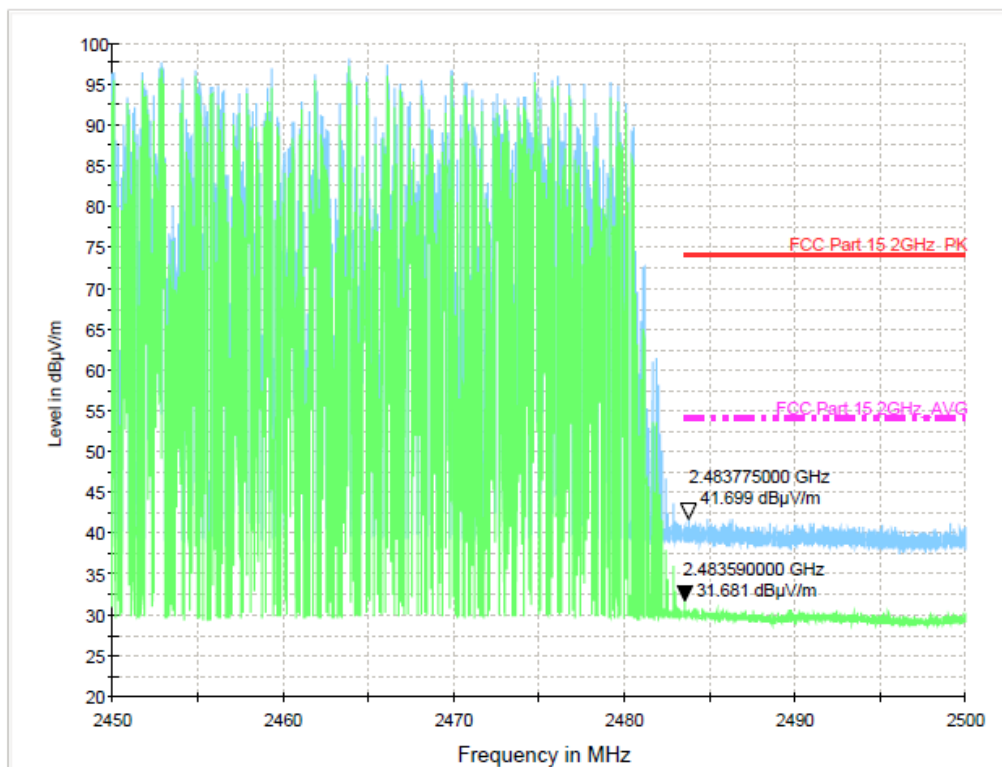

hopping-on

Note: 1. *:Maximum data; x:Over limit; !:over margin.

2.Measurement=Reading Level+Correct Factor; Correct Factor=Antenna Factor+Cable Loss.

Conducted Method

GFSK Mode:

Test channel:

Lowest channel

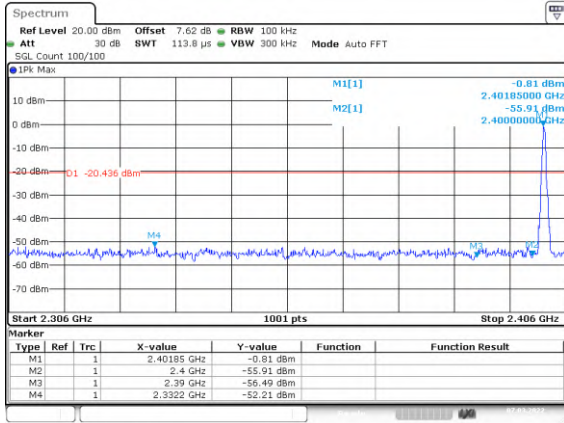

Date: 7.MAR.2022 11:18:24

No-hopping mode

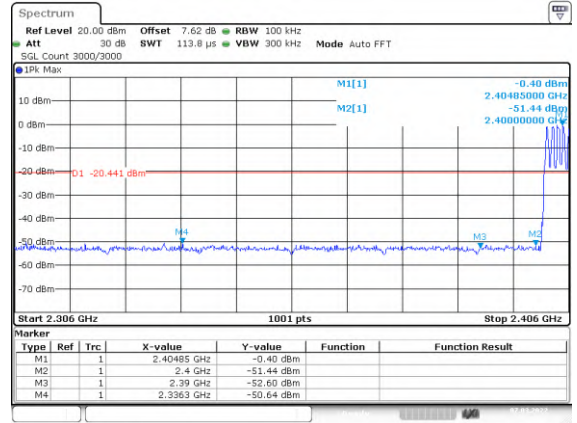

Date: 7.MAR.2022 11:43:36

Hopping mode

Test channel:

Highest channel

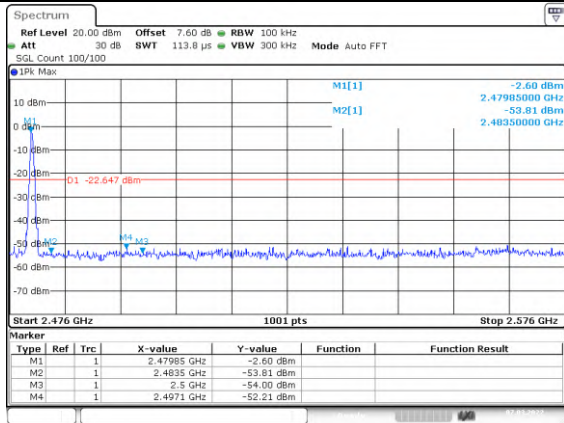

Date: 7.MAR.2022 11:21:30

No-hopping mode

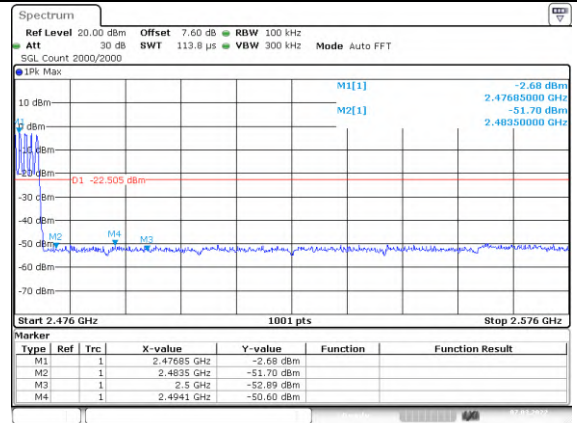

Date: 7.MAR.2022 11:54:16

Hopping mode

Pi/4QPSK Mode:

Test channel:

Lowest channel

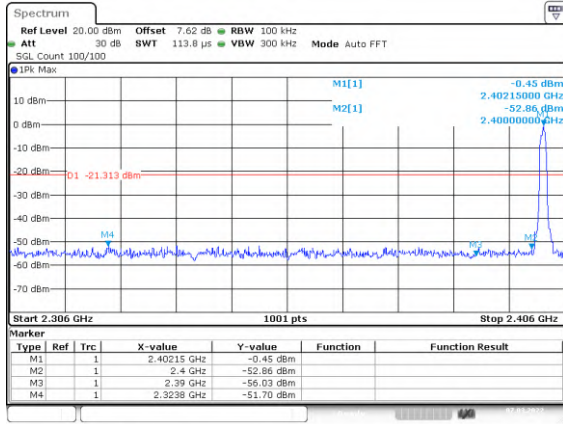

Date: 7.MAR.2022 11:37:50

No-hopping mode

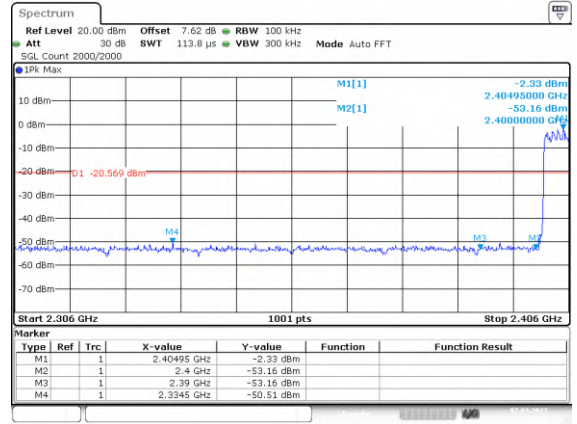

Date: 7.MAR.2022 12:33:20

Hopping mode

Test channel:

Highest channel

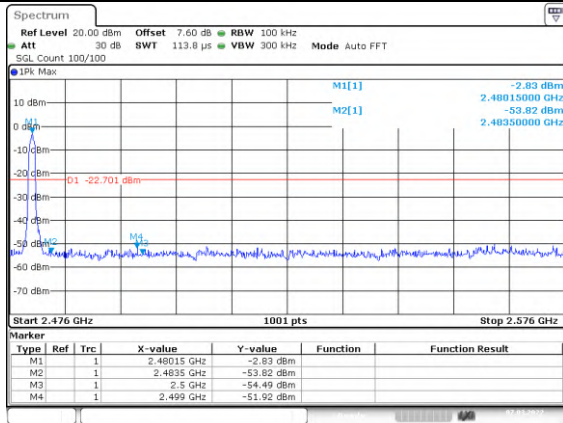

Date: 7.MAR.2022 11:36:01

No-hopping mode

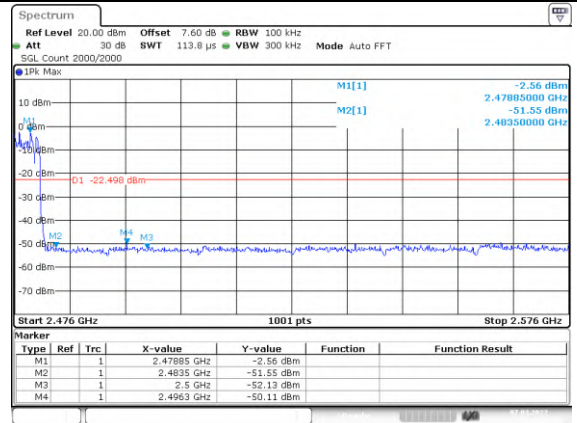

Date: 7.MAR.2022 13:13:29

Hopping mode

8DPSK Mode:

Test channel:

Lowest channel

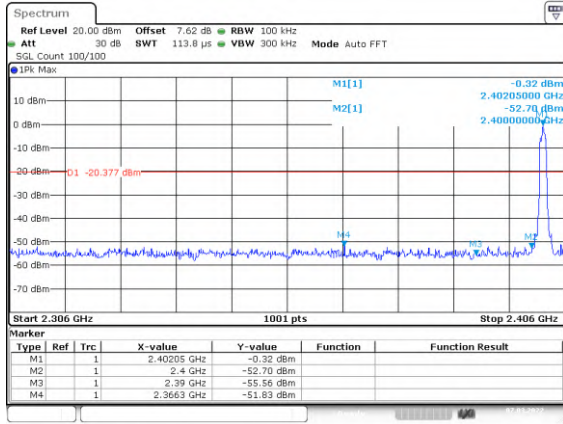

Date: 7.MAR.2022 11:40:02

No-hopping mode

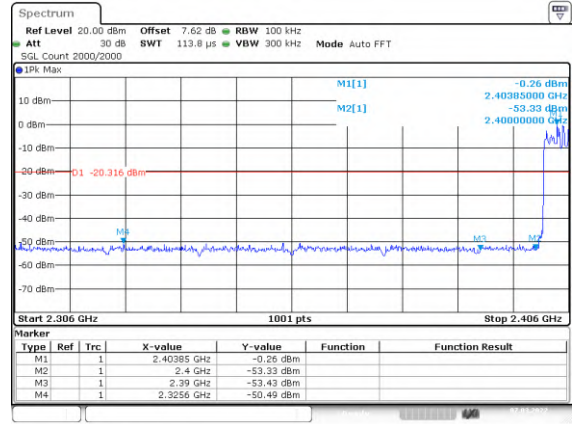

Date: 7.MAR.2022 13:19:13

Hopping mode

Test channel:

Highest channel

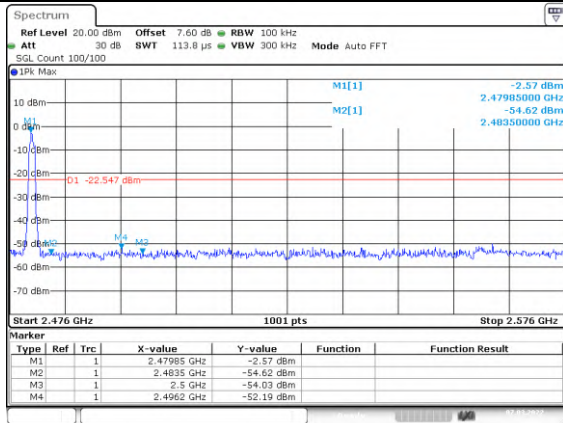

Date: 7.MAR.2022 11:34:27

No-hopping mode

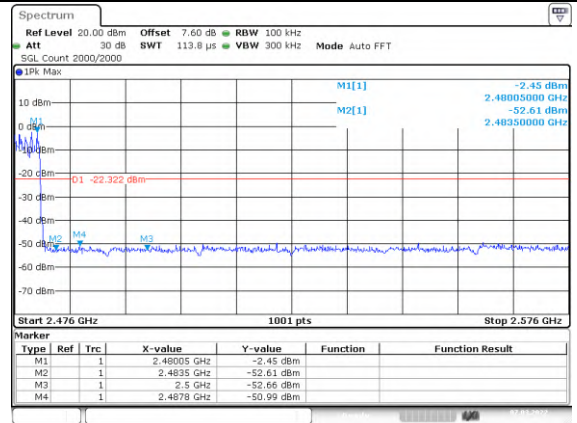

Date: 7.MAR.2022 13:27:12

Hopping mode

10. Power Line Conducted Emissions

10.1. Block Diagram of Test Setup

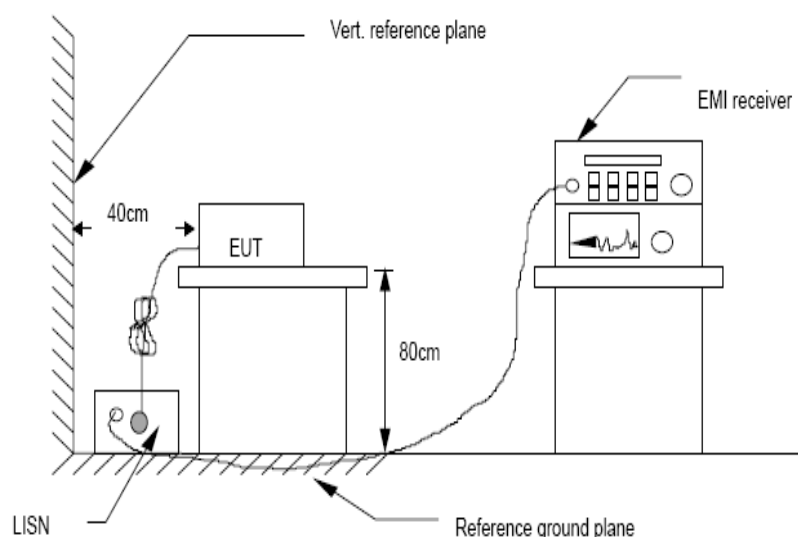

10.2. Limit

Frequency	Maximum RF Line Voltage	
	Quasi-Peak Level dB(μ V)	Average Level dB(μ V)
150kHz ~ 500kHz	66 ~ 56*	56 ~ 46*
500kHz ~ 5MHz	56	46
5MHz ~ 30MHz	60	50

Notes: 1. * Decreasing linearly with logarithm of frequency.

2. The lower limit shall apply at the transition frequencies.

10.3. Test Procedure

- (1) The EUT was placed on a non-metallic table, 80cm above the ground plane.
- (2) Setup the EUT and simulator as shown in 10.1
- (3) The EUT Power connected to the power mains through a power adapter and a line impedance stabilization network (L.I.S.N1). The other peripheral devices power cord connected to the power mains through a line impedance stabilization network (L.I.S.N2), this provided a 50-ohm coupling impedance for the EUT (Please refer to the block diagram of the test setup and photographs). Both sides of power line were checked for maximum conducted interference. In order to find the maximum emission, the relative positions of equipments and all of the interface cables were changed according to ANSI C63.10:2013on conducted Emission test.
- (4) The bandwidth of test receiver is set at 10KHz.

(5) The frequency range from 150 KHz to 30MHz is checked.

10.4. Test Result

PASS. (See below detailed test data)

Note: If peak Result comply with AV limit, QP and AV Result is deemed to comply with AV limit

Line:

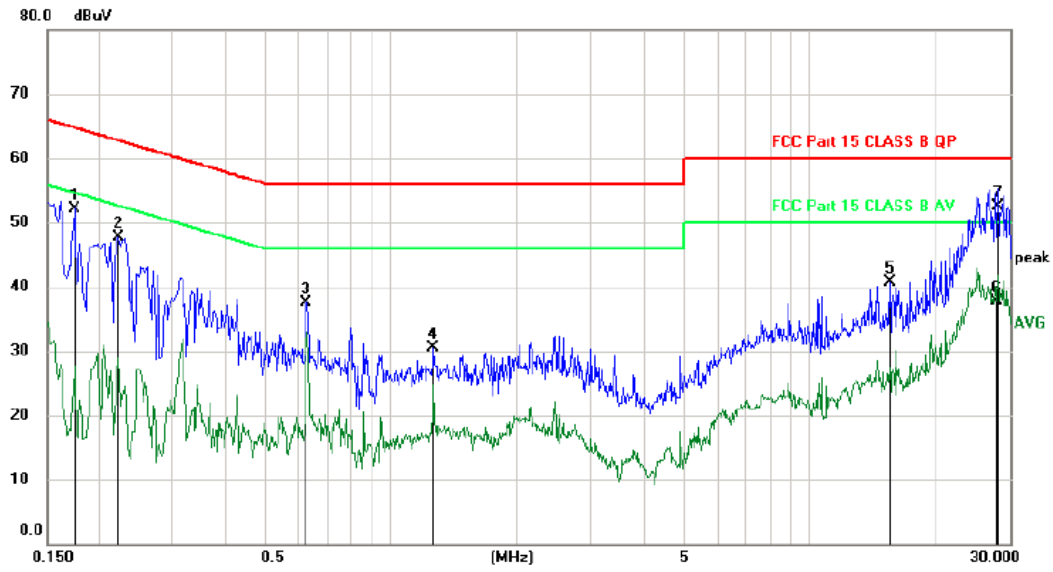

No.	Mk.	Freq. MHz	Reading Level dBuV	Correct Factor dB	Measure- ment dBuV	Limit dBuV	Margin dB	Detector	Comment
1		0.1737	42.27	9.93	52.20	64.78	-12.58	peak	
2		0.2220	37.76	9.94	47.70	62.74	-15.04	peak	
3		0.6270	27.64	9.92	37.56	56.00	-18.44	peak	
4		1.2566	20.52	9.89	30.41	56.00	-25.59	peak	
5		15.4710	30.38	10.34	40.72	60.00	-19.28	peak	
6		27.8880	27.04	10.57	37.61	50.00	-12.39	AVG	
7	*	28.0710	42.02	10.58	52.60	60.00	-7.40	QP	

Note: Measurement=Reading Level+Correc Factor. Factor=(LISN or ISN or PLC or Current Probe)Factor+Cable

Neutral:

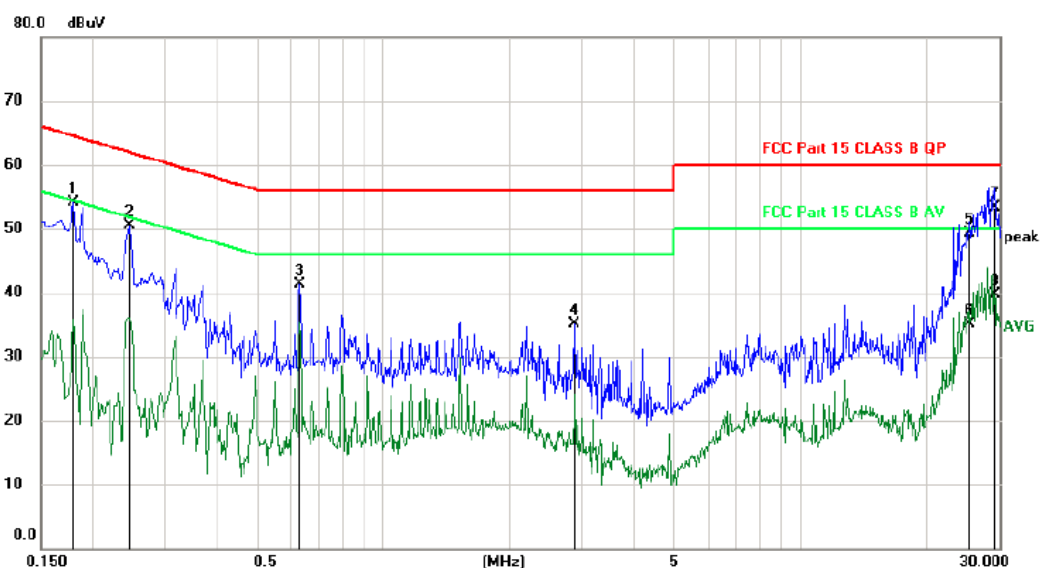

No.	Mk.	Freq. MHz	Reading Level dBuV	Correct Factor dB	Measure- ment dBuV	Limit dBuV	Margin dB	Detector	Comment
1		0.1800	44.11	9.93	54.04	64.49	-10.45	peak	
2		0.2459	40.52	9.97	50.49	61.89	-11.40	peak	
3		0.6300	31.36	9.92	41.28	56.00	-14.72	peak	
4		2.8679	25.08	9.94	35.02	56.00	-20.98	peak	
5		25.5060	38.86	10.46	49.32	60.00	-10.68	QP	
6		25.5060	24.65	10.46	35.11	50.00	-14.89	AVG	
7	*	29.2500	42.57	10.64	53.21	60.00	-6.79	QP	
8		29.2500	29.09	10.64	39.73	50.00	-10.27	AVG	

Note: Measurement=Reading Level+Correc Factor. Factor=(LISN or ISN or PLC or Current Probe)Factor+Cable

Remark: All modes have been tested, and only worst data of GFSK mode, Channel 2441MHz (AC 120V/60Hz) was listed in this report.

11. Antenna Requirements

11.1. Limit

For intentional device, according to FCC 47 CFR Section 15.203 and RSS-GEN, an intentional radiator shall be designed to ensure that no antenna other than that furnished by the responsible party shall be used with the device. And according to FCC 47 CFR Section 15.247 (b), if transmitting antennas of directional gain greater than 6dBi are used, the power shall be reduced by the amount in dB that the directional gain of the antenna exceeds 6dBi.

11.2. Result

The EUT antenna is internal antenna. It complies with the standard requirement.

12. Test Setup Photo

12.1. Photos of Radiated emission

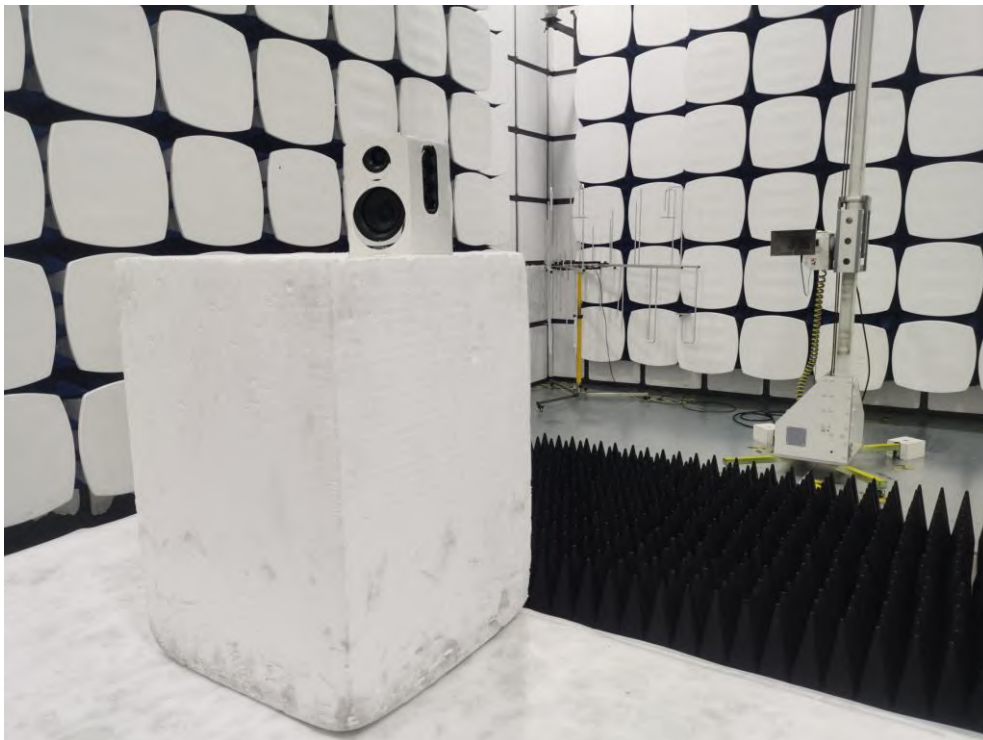



12.2.Photos of Conducted Emission test

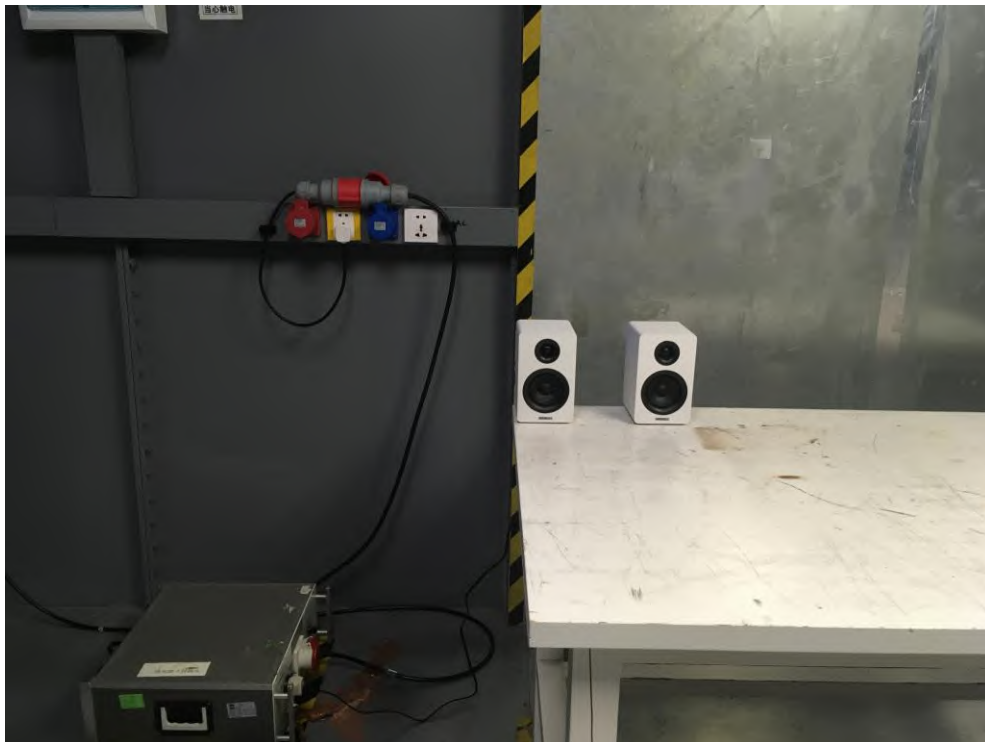



13.EUT Photo

Please refer to the report A2202088-C01-R01.

14. Annex

Model List				
SW-208	SW-228BT	SW-206	SW-201	SW-202
SW-203	SW-205	SW-209	SW-210	SW-211
SW-212	SW-213	SW-215	SW-216	SW-218
SW-219	SW-220	SW-221	SW-222	SW-223
SW-225	SW-226	SW-228	SW-229	SW-010
SW-009	SW-008	SW-006	SW-005	SW-003
SW-002	SW-001	SW-011	SW-012	SW-013
SW-015	SW-016	SW-018	SW-019	SW-020
SW-021	SW-022	SW-023	SW-025	SW-026
SW-028	SW-029			

-----THE END OF REPORT-----