

FCC PART 15C
Measurement and Test Report
For
Jiangxi EQi Industrial Co., Ltd

FCC ID:2A4NH-URTM026

| | | |
|--|--|--------------------|
| FCC Rule(s)/Methods: | FCC CFR Title 47 Part 15 Subpart C Section 15.231 ANSI C63.10:2013 | |
| Product Description: | Fitness Walker | |
| Trademark: | EQi, Urevo, Superfit, costway | |
| Model/Type reference.: | URTM026, N4001, N4024, N4068, N4076, N4077, N4077B, N4078, N4079, N4083, N4084, N4091, N4092, N4093, N4094,N4095, N4097, N3802, N3821, N3822, N3827A, N3837, N4237, N4253, N4051,N4231,GT6, GT8, LS1, LS3, LS5, ZX1, ZX3, ZX5, ZX7, CS-WP6. | |
| Report No.: | BSL2305318275043F | |
| Date of receipt of test item: | Sep. 27, 2023 | |
| Date of sampling: | Sep. 27, 2023 | |
| Tested Date: | Sep. 27, 2023 to Oct. 12, 2023 | |
| Issued Date: | Oct. 12, 2023 | |
| Tested By: | Cindy Zheng/ Engineer | <i>Cindy zheng</i> |
| Reviewed By: | Haley Wen/ EMC Manager | <i>Haley wen</i> |
| Approved & Authorized By: | Mike Mo / PSQ Manager | <i>Mike Mo</i> |
| BSL Testing Co.,LTD. | | |
| 1/F, Building B, Xinshidai GR Park, Shiyan Street, Bao'an District, Shenzhen, Shiyan Street, Bao'an District, Shenzhen, Guangdong, 518052, People' s Republic of China Tel: 400-882-9628 Fax: 86- 755-26508703 | | |

| Table of Contents | Page |
|---|------|
| 1. Version | 4 |
| 2. SUMMARY OF TEST RESULTS | 5 |
| 2.1 TEST FACILITY | 6 |
| 2.2 MEASUREMENT UNCERTAINTY | 6 |
| 3. GENERAL INFORMATION | 7 |
| 3.1 GENERAL DESCRIPTION | 7 |
| 3.2 DESCRIPTION OF TEST MODES | 8 |
| 3.3 BLOCK DIGRAM SHOWING THE CONFIGURATION OF SYSTEM TESTED | 8 |
| 3.4 DESCRIPTION OF SUPPORT UNITS(CONDUCTED MODE) | 8 |
| 3.5 EQUIPMENTS LIST FOR ALL TEST ITEMS | 9 |
| 4. EMC EMISSION TEST | 10 |
| 4.1 CONDUCTED EMISSION MEASUREMENT | 10 |
| 4.1.1 POWER LINE CONDUCTED EMISSION Limits | 10 |
| 4.1.2 TEST PROCEDURE | 11 |
| 4.1.3 DEVIATION FROM TEST STANDARD | 11 |
| 4.1.4 TEST SETUP | 11 |
| 4.1.5 EUT OPERATING CONDITIONS | 11 |
| 4.1.6 TEST RESULTS | 11 |
| 4.2 RADIATED EMISSION MEASUREMENT | 12 |
| 4.2.1 Radiated Emission Limits | 12 |
| 4.2.2 TEST PROCEDURE | 13 |
| 4.2.3 TEST SETUP | 14 |
| 4.2.4 EUT OPERATING CONDITIONS | 15 |
| 4.2.5 TEST RESULTS | 15 |
| 5.1 Applied procedures / limit | 20 |
| 5.2 TEST PROCEDURE | 20 |
| 5.3 DEVIATION FROM STANDARD | 20 |
| 5.4 TEST SETUP | 20 |
| 5.5 EUT OPERATION CONDITIONS | 20 |
| 5.6 Test results | 21 |
| 6. Calculation of Average Factor | 22 |
| 7. Dwell time | 24 |
| 7.1 Applicable Standard | 24 |
| 7.2 Test Procedure | 24 |
| 7.5 EUT OPERATION CONDITIONS | 24 |
| 7.6 TEST RESULTS | 25 |

Table of Contents

Page

8. ANTENNA REQUIREMENT 26

9. Test Setup Photo 27

10. EUT Constructional Details 27

1. VERSION

| Report No. | Version | Description | Approved |
|-------------------|---------|-------------------------|---------------|
| BSL2305318275043F | Rev.01 | Initial issue of report | Oct. 12, 2023 |
| | | | |
| | | | |

2. SUMMARY OF TEST RESULTS

Test procedures according to the technical standards:

| FCC Part15 (15.231) , Subpart C | | | |
|---------------------------------|---|----------|--------|
| Standard Section | Test Item | Judgment | Remark |
| 15.207 | Conducted Emission | N/A | |
| 15.209,15.231b | Fundamental &Radiated Spurious Emission Measurement | PASS | |
| 15.231c | Occupy Bandwidth | PASS | |
| 15.231a | Dwell time | PASS | |
| 15.203 | Antenna Requirement | PASS | |

NOTE:

(1) " N/A" denotes test is not applicable in this Test Report

2.1 TEST FACILITY

Shenzhen BSL Technology Co., Ltd.

Add. : 1/F, Building B, Xinshidai GR Park, Shiyan Street, Bao'an District, Shenzhen, Shiyan Street,
Bao'an District, Shenzhen, Guangdong, 518052, People' s Republic of China

FCC Test Firm Registration Number: 562200

Designation Number: CN1338

IC Registered No.: 11093A

Designation Number: CN0019

2.2 MEASUREMENT UNCERTAINTY

The reported uncertainty of measurement $y \pm U$ · where expanded uncertainty U is based on a standard uncertainty multiplied by a coverage factor of $k=2$ · providing a level of confidence of approximately 95 % .

| No. | Item | Uncertainty |
|-----|---|-------------|
| 1 | 3m chamber Radiated spurious emission(9KHz-30MHz) | U=4.5dB |
| 2 | 3m chamber Radiated spurious emission(30MHz-1GHz) | U=4.8dB |
| 3 | 3m chamber Radiated spurious emission(1GHz-6GHz) | U=4.9dB |
| 4 | 3m chamber Radiated spurious emission(6GHz-40GHz) | U=5.0dB |
| 5 | Conducted disturbance | U=3.2dB |
| 6 | RF Band Edge | U=1.68dB |
| 7 | RF power conducted | U=1.86dB |
| 8 | RF conducted Spurious Emission | U=2.2dB |
| 9 | RF Occupied Bandwidth | U=1.8dB |
| 10 | RF Power Spectral Density | U=1.75dB |
| 11 | humidity uncertainty | U=5.3% |
| 12 | Temperature uncertainty | U=0.59°C |

3. GENERAL INFORMATION

3.1 GENERAL DESCRIPTION

| | |
|--------------------------|--|
| Applicant: | Jiangxi EQi Industrial Co., Ltd |
| Address of applicant: | Luliang Road, Yining Town, Xiushui County, Jiujiang City, Jiangxi Province |
| Manufacturer: | Jiangxi EQi Industrial Co., Ltd |
| Address of manufacturer: | Luliang Road, Yining Town, Xiushui County, Jiujiang City, Jiangxi Province |
| Equipment | Fitness Walker |
| Trade Name | EQi, Urevo, Superfit, costway |
| Model Name | URTM026, N4001, N4024, N4068, N4076, N4077, N4077B, N4078, N4079, N4083, N4084, N4091, N4092, N4093, N4094, N4095, N4097, N3802, N3821, N3822, N3827A, N3837, N4237, N4253, N4051, N4231, GT6, GT8, LS1, LS3, LS5, ZX1, ZX3, ZX5, ZX7, CS-WP6. |
| Model Difference | Only the model names are different. |
| Hardware version | V1.0 |
| Software version | V1.0 |
| Operation Frequency: | 433.92MHz |
| Modulation Type: | ASK |
| Antenna Type: | PCB Antenna |
| Antenna Gain: | 0dBi(Declaration by applicant) |
| Ratings | Transmitter: DC 3V Form Battery Receiver: AC 120V/60Hz |

3.2 DESCRIPTION OF TEST MODES

| For All Emission | |
|-------------------|--|
| Final Test Mode | Description |
| Transmitting mode | Keep the EUT in continuously transmitting mode |

Note:

- (1) New battery is used during the test

3.3 BLOCK DIGRAM SHOWING THE CONFIGURATION OF SYSTEM TESTED

RE Spurious emissions

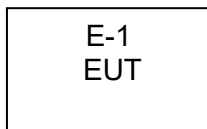

3.4 DESCRIPTION OF SUPPORT UNITS(CONDUCTED MODE)

The EUT has been tested as an independent unit together with other necessary accessories or support units. The following support units or accessories were used to form a representative test configuration during the tests.

| Item | Equipment | Mfr/Brand | Model/Type No. | Series No. | Note |
|------|-----------|-----------|----------------|------------|------|
| | | | | | |
| | | | | | |

| Item | Shielded Type | Ferrite Core | Length | Note |
|------|---------------|--------------|--------|------|
| | | | | |

Note:

- (1) The support equipment was authorized by Declaration of Confirmation.
- (2) For detachable type I/O cable should be specified the length in cm in 『Length』 column.
- (3) “YES” is means “shielded” “with core”; “NO” is means “unshielded” “without core”.

3.5 EQUIPMENTS LIST FOR ALL TEST ITEMS

Radiation Test equipment

| Item | Equipment | Manufacturer | Type No. | Serial No. | Last calibration | Calibrated until |
|------|-------------------------------------|------------------|--------------------|-------------------------------------|------------------|------------------|
| 1 | Communication Tester | Rohde & Schwarz | CMW500 | 100358 Fireware: 4.43 SP4 | Oct. 17, 2022 | Oct. 16, 2023 |
| 2 | Spectrum Analyzer | KEYSIGHT | 9020A | MY55370835 | Oct. 18, 2022 | Oct. 17, 2023 |
| 3 | Test Receiver | R&S | ESC17 | US47140102 Fireware: 4.42 SP3 | Oct. 17, 2022 | Oct. 16, 2023 |
| 4 | Signal Generator | HP | 83630B | 3844A01028 | Oct. 17, 2022 | Oct. 16, 2023 |
| 5 | Signal Generator | IFR | 2023A | 202307/242 | Oct. 17, 2022 | Oct. 16, 2023 |
| 6 | Amplifier | Agilent | 8449B | 4035A00116 | Oct. 17, 2022 | Oct. 16, 2023 |
| 7 | Amplifier | HP | 8447E | 2945A02770 | Oct. 17, 2022 | Oct. 16, 2023 |
| 8 | Broadband Antenna | SCHAFFNER | 2774 | 2774 | Feb.28,2022 | Feb.27,2025 |
| 9 | Biconical and log periodic antennas | Schwarzbeck | VULB9168 | N/A | Oct. 17, 2022 | Oct. 16, 2023 |
| 10 | Horn Antenna | R&S | HF906 | 100253 | Feb.28,2022 | Feb.27,2025 |
| 11 | Horn Antenna | Schwarzbeck | BBHA9170 | 00814 | Feb.28,2022 | Feb.27,2025 |
| 12 | Horn Antenna | EM | EM-6961 | 6462 | Feb.28,2022 | Feb.27,2025 |
| 13 | 3m Semi-Anechoic Chamber | Chengyu Electron | 9 (L)*6 (W)* 6 (H) | BSL086 | Feb.28,2022 | Feb.27,2025 |
| 14 | Loop Antenna | ZHINAN | ZN30900C | 20073 | Feb.28,2022 | Feb.27,2025 |
| 15 | power meter | DARE | RPR3006W | 15I00041SNO0 | Oct. 17, 2022 | Oct. 16, 2023 |
| 16 | RF Control Unit | MWRFtest | Mw100 | - | Feb.28,2022 | Feb.27,2025 |
| 17 | Test software | MWRFtest | V8310 | - | - | - |
| 18 | Turntable | MF | MF-7802BS | N/A | \ | \ |
| 19 | Antenna tower | MF | MF-7802BS | N/A | \ | \ |
| 20 | Signal Generator | Agilent | N5182A | N/A | Oct. 22, 2022 | Oct. 21, 2023 |

RF Conduction Test equipment

| Item | Kind of Equipment | Manufacturer | Type No. | Serial No. | Last calibration | Calibrated until |
|------|----------------------------------|--------------|------------|------------|------------------|------------------|
| 1 | Spectrum Analyzer (9kHz-26.5GHz) | KEYSIGHT | 9020A | MY55370835 | Oct. 17, 2022 | Oct. 16, 2023 |
| 2 | MWRF Power Meter Test system | MW | MW100-RPCB | N/A | Oct. 17, 2022 | Oct. 16, 2023 |
| 3 | D.C. Power Supply | LongWei | TPR-6405D | N/A | \ | \ |
| 4 | RF Software | MW | MTS8310 | V2.0.0.0 | \ | \ |

4. EMC EMISSION TEST

4.1 CONDUCTED EMISSION MEASUREMENT

| | |
|-----------------------|--------------------------------------|
| Test Requirement: | FCC Part15 C Section 15.207 |
| Test Method: | ANSI C63.10:2013 |
| Test Frequency Range: | 150KHz to 30MHz |
| Receiver setup: | RBW=9KHz, VBW=30KHz, Sweep time=auto |

4.1.1 POWER LINE CONDUCTED EMISSION LIMITS

(Frequency Range 150KHz-30MHz)

| FREQUENCY (MHz) | Limit (dBuV) | | Standard |
|-----------------|--------------|-----------|----------|
| | Quasi-peak | Average | |
| 0.15 -0.5 | 66 - 56 * | 56 - 46 * | FCC |
| 0.50 -5.0 | 56.00 | 46.00 | FCC |
| 5.0 -30.0 | 60.00 | 50.00 | FCC |

Note:

- (1) The tighter limit applies at the band edges.
- (2) The limit of " * " marked band means the limitation decreases linearly with the logarithm of the frequency in the range.

The following table is the setting of the receiver

| Receiver Parameters | Setting |
|---------------------|----------|
| Attenuation | 10 dB |
| Start Frequency | 0.15 MHz |
| Stop Frequency | 30 MHz |
| IF Bandwidth | 9 kHz |

4.1.2 TEST PROCEDURE

- The EUT was placed 0.8 meters from the horizontal ground plane with EUT being connected to the power mains through a line impedance stabilization network (LISN). All other support equipments powered from additional LISN(s). The LISN provide 50 Ohm/ 50uH of coupling impedance for the measuring instrument.
- Interconnecting cables that hang closer than 40 cm to the ground plane shall be folded back and forth in the center forming a bundle 30 to 40 cm long.
- I/O cables that are not connected to a peripheral shall be bundled in the center. The end of the cable may be terminated, if required, using the correct terminating impedance. The overall length shall not exceed 1 m.
- LISN at least 80 cm from nearest part of EUT chassis.
- For the actual test configuration, please refer to the related Item –EUT Test Photos.

4.1.3 DEVIATION FROM TEST STANDARD

No deviation

4.1.4 TEST SETUP

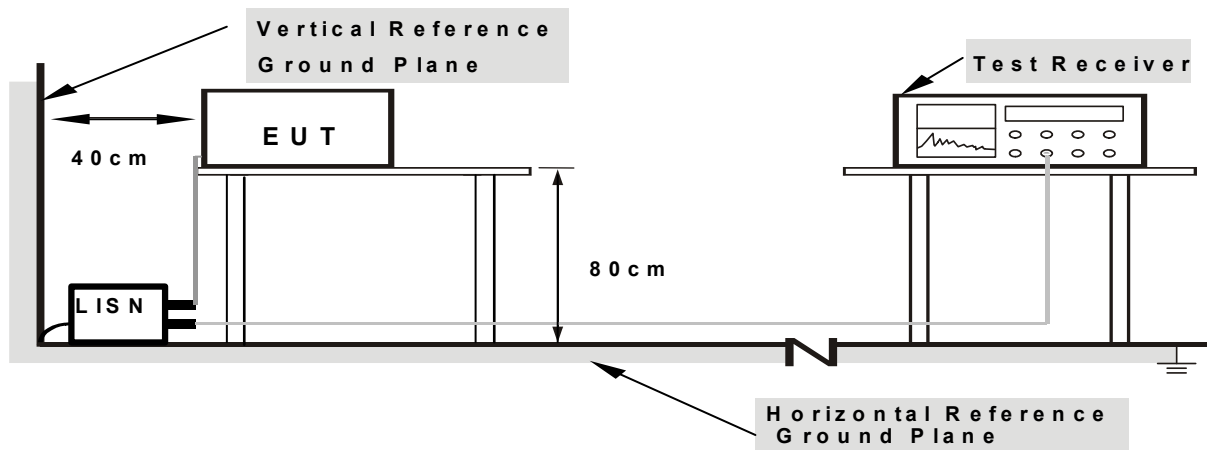

- Note:**
- Support units were connected to second LISN.
 - Both of LISNs (AMN) are 80 cm from EUT and at least 80 cm from other units and other metal planes

4.1.5 EUT OPERATING CONDITIONS

The EUT was configured for testing in a typical fashion (as a customer would normally use it). The EUT has been programmed to continuously transmit during test. This operating condition was tested and used to collect the included data.

4.1.6 TEST RESULTS

The EUT is powered by the DC only, the test item is not applicable.

4.2 RADIATED EMISSION MEASUREMENT

| | | | | | |
|-----------------------|-----------------------------|------------|--------|---------|------------|
| Test Requirement: | FCC Part15 C Section 15.209 | | | | |
| Test Method: | ANSI C63.10:2013 | | | | |
| Test Frequency Range: | 9kHz to 25GHz | | | | |
| Test site: | Measurement Distance: 3m | | | | |
| Receiver setup: | Frequency | Detector | RBW | VBW | Value |
| | 9KHz-150KHz | Quasi-peak | 200Hz | 600Hz | Quasi-peak |
| | 150KHz-30MHz | Quasi-peak | 9KHz | 30KHz | Quasi-peak |
| | 30MHz-1GHz | Quasi-peak | 100KHz | 300KHz | Quasi-peak |
| | Above 1GHz | Peak | 1MHz | 3MHz | Peak |
| Peak | | 1MHz | 10Hz | Average | |

4.2.1 RADIATED EMISSION LIMITS

20dBc in any 100 kHz bandwidth outside the operating frequency band. In case the emission fall within the restricted band specified on 15.205(a), then the 15.231(b) limit in the table below has to be followed.

| Frequencies(MHz) | Field Strength(micorvolts/meter) | Measurement Distance(meters) |
|------------------|----------------------------------|------------------------------|
| 0.009~0.490 | 2400/F(KHz) | 300 |
| 0.490~1.705 | 24000/F(KHz) | 30 |
| 1.705~30.0 | 30 | 30 |
| 30~88 | 100 | 3 |
| 88~216 | 150 | 3 |
| 216~960 | 200 | 3 |
| Above 960 | 500 | 3 |

LIMITS OF RADIATED EMISSION MEASUREMENT

| FREQUENCY (MHz) | Limit (dBuV/m) (at 3M) | |
|-----------------|------------------------|---------|
| | PEAK | AVERAGE |
| Above 1000 | 74 | 54 |

Notes:

- (1) The limit for radiated test was performed according to FCC PART 15C.
- (2) The tighter limit applies at the band edges.
- (3) Emission level (dBuV/m)=20log Emission level (uV/m).

FUNDAMENTAL AND HARMONICS EMISSION LIMITS

| Fundamental Frequency (MHz) | Field Strength of Fundamental (microvolts/meter) | Field Strength of Spurious Emissions (microvolts/meter) |
|-----------------------------|--|---|
| 40.66 - 40.70 | 2,250 | 225 |
| 70 - 130 | 1,250 | 125 |
| 130 - 174 | 1,250 to 3,750 ** | 125 to 375 ** |
| 174 - 260 | 3,750 | 375 |
| 260 - 470 | 3,750 to 12,500 ** | 375 to 1,250 ** |
| Above 470 | 12,500 | 1,250 |

** linear interpolations

[Where F is the frequency in MHz, the formulas for calculating the maximum permitted fundamental field strengths are as follows: for the band 130-174 MHz, $\mu\text{V/m}$ at 3 meters = $56.81818(F) - 6136.3636$; for the band 260-470 MHz, $\mu\text{V/m}$ at 3 meters = $41.6667(F) - 7083.3333$. The maximum permitted unwanted emission level is 20 dB below the maximum permitted fundamental level.]

FREQUENCY RANGE OF RADIATED MEASUREMENT (For unintentional radiators)

| Highest frequency generated or Upper frequency of measurement used in the device or on which the device operates or tunes (MHz) | Range (MHz) |
|---|---|
| Below 1.705 | 30 |
| 1.705 – 108 | 1000 |
| 108 – 500 | 2000 |
| 500 – 1000 | 5000 |
| Above 1000 | 5 th harmonic of the highest frequency or 40 GHz, whichever is lower |

| Spectrum Parameter | Setting |
|--------------------|--|
| Attenuation | Auto |
| Start Frequency | 1000 MHz |
| Stop Frequency | 10th carrier harmonic |
| RBW / VBW setting | 1 MHz / 1 MHz for Peak, 1 MHz / 10Hz for Average |

| Receiver Parameter | Setting |
|------------------------|----------------------------------|
| Attenuation | Auto |
| Start ~ Stop Frequency | 9kHz~150kHz / RB 200Hz for QP |
| Start ~ Stop Frequency | 150kHz~30MHz / RB 9kHz for QP |
| Start ~ Stop Frequency | 30MHz~1000MHz / RB 120kHz for QP |

4.2.2 TEST PROCEDURE

- a. The measuring distance of at 3 m shall be used for measurements at frequency up to 1GHz. For frequencies above 1GHz, any suitable measuring distance may be used.
- b. The EUT was placed on the top of a rotating table 0.8 meters above the ground at a 3 meter open area test site. The table was rotated 360 degrees to determine the position of the highest radiation.
- c. The height of the equipment or of the substitution antenna shall be 0.8 m; above 1GHz, the height was 1.5m, the height of the test antenna shall vary between 1 m to 4 m. Both horizontal and vertical polarizations of the antenna are set to make the measurement.

- d. The initial step in collecting conducted emission data is a spectrum analyzer peak detector mode pre-scanning the measurement frequency range. Significant peaks are then marked and then Quasi Peak detector mode re-measured.
- e. If the Peak Mode measured value compliance with and lower than Quasi Peak Mode Limit, the EUT shall be deemed to meet QP Limits and then no additional QP Mode measurement performed.
- f. For the actual test configuration, please refer to the related Item –EUT Test Photos.

Note:

Both horizontal and vertical antenna polarities were tested and performed pretest to three orthogonal axis. The worst case was X axis and the emissions were reported

4.2.3 TEST SETUP

(A) Radiated Emission Test-Up Frequency Below 30MHz

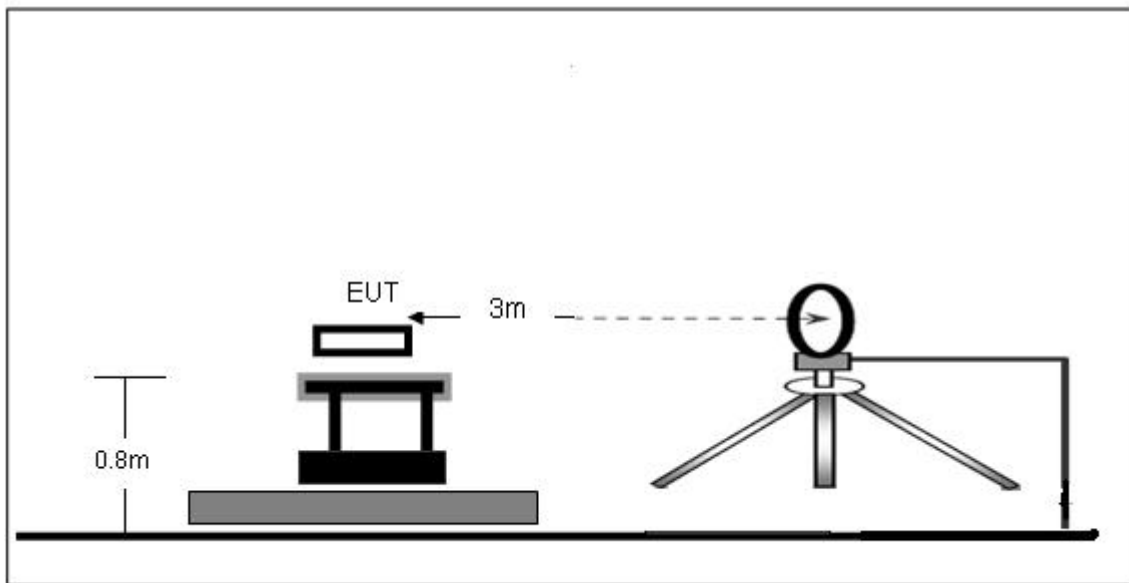

(B) Radiated Emission Test-Up Frequency 30MHz~1GHz

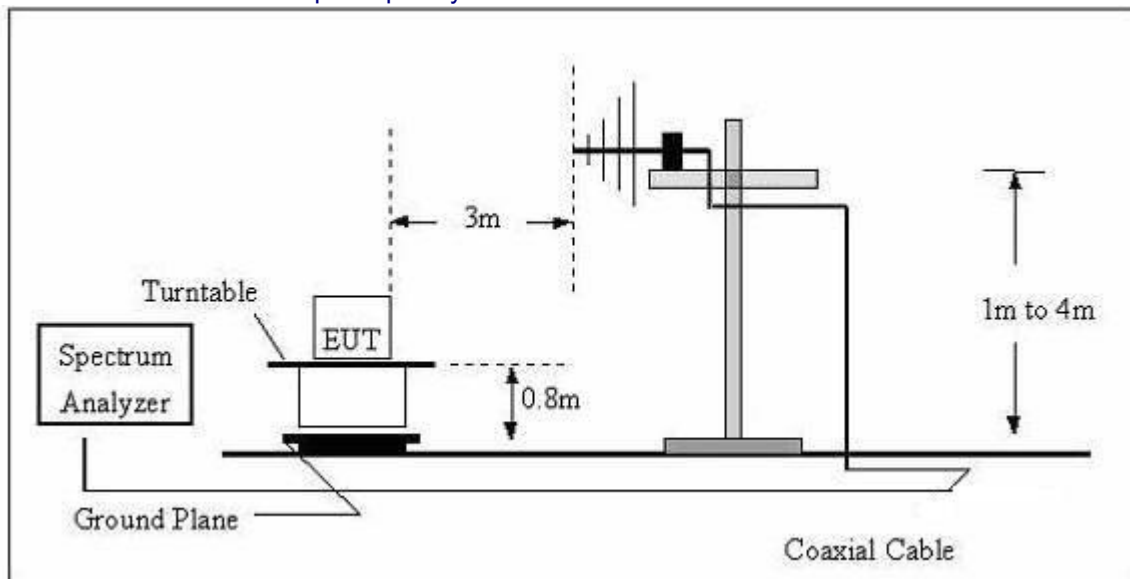

(C) Radiated Emission Test-Up Frequency Above 1GHz

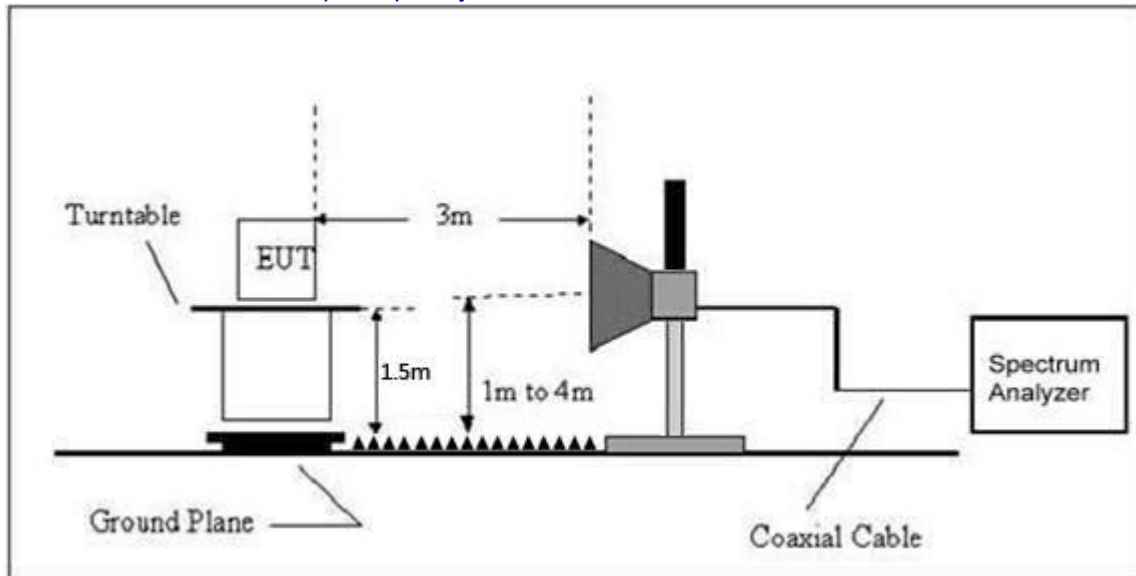

4.2.4 EUT OPERATING CONDITIONS

The EUT tested system was configured as the statements of 2.4 Unless otherwise a special operating condition is specified in the follows during the testing.

4.2.5 TEST RESULTS

Radiated Spurious Emission (Below 9KHz – 30MHz)

| | | | |
|----------------|---------|---------------------|-----|
| Temperature : | 26 °C | Relative Humidity : | 54% |
| Pressure : | 101 kPa | Polarization : | --- |
| Test Voltage : | DC 3V | | |
| Test Mode : | TX Mode | | |

| Freq. (MHz) | Reading (dBuV/m) | Limit (dBuV/m) | Margin (dB) | State P/F |
|----------------|---------------------|-------------------|----------------|--------------|
| -- | -- | -- | -- | PASS |
| -- | -- | -- | -- | PASS |

NOTE:

The amplitude of spurious emissions which are attenuated by more than 20dB below the permissible value has no need to be reported.

Distance extrapolation factor = $40 \log (\text{specific distance}/\text{test distance})(\text{dB})$;

Limit line = specific limits(dBuv) + distance extrapolation factor.

Radiated Spurious Emission (Between 30MHz – 1GHz)

| | | | |
|----------------|---------|---------------------|------------|
| Temperature : | 26 °C | Relative Humidity : | 54% |
| Pressure : | 101 kPa | Polarization : | Horizontal |
| Test Voltage : | DC 3V | | |
| Test Mode : | TX Mode | | |

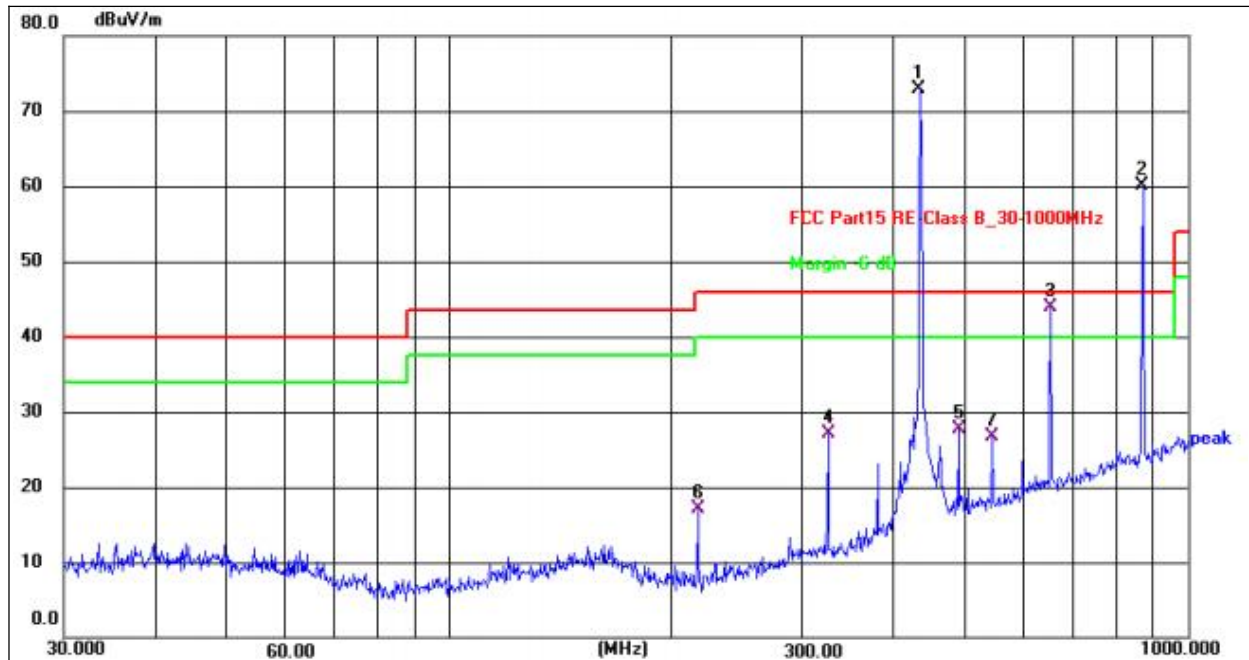

| No. | Frequency (MHz) | Reading (dBuV) | Factor (dB/m) | Level (dBuV/m) | Limit (dBuV/m) | Margin (dB) | Detector |
|-----|-----------------|----------------|---------------|----------------|----------------|-------------|----------|
| 1 * | 433.9200 | 85.26 | -12.29 | 72.97 | 100.8 | -27.83 | peak |
| 2 X | 867.8400 | 64.20 | -4.05 | 60.15 | 80.8 | -20.65 | peak |
| 3 ! | 651.9416 | 51.60 | -7.71 | 43.89 | 46.00 | -2.11 | QP |
| 4 | 325.5957 | 42.39 | -15.34 | 27.05 | 46.00 | -18.95 | QP |
| 5 | 489.0267 | 38.76 | -11.09 | 27.67 | 46.00 | -18.33 | QP |
| 6 | 216.7828 | 36.24 | -19.23 | 17.01 | 46.00 | -28.99 | QP |
| 7 | 543.2741 | 36.66 | -9.89 | 26.77 | 46.00 | -19.23 | QP |

Remarks:

- 1.Final Level =Receiver Read level + Antenna Factor + Cable Loss – Preamplifier Factor
- 2.The emission levels of other frequencies are very lower than the limit and not show in test report.

| | | | |
|----------------|---------|---------------------|----------|
| Temperature : | 26 °C | Relative Humidity : | 54% |
| Pressure : | 101 kPa | Polarization : | Vertical |
| Test Voltage : | DC 3V | | |
| Test Mode : | TX Mode | | |

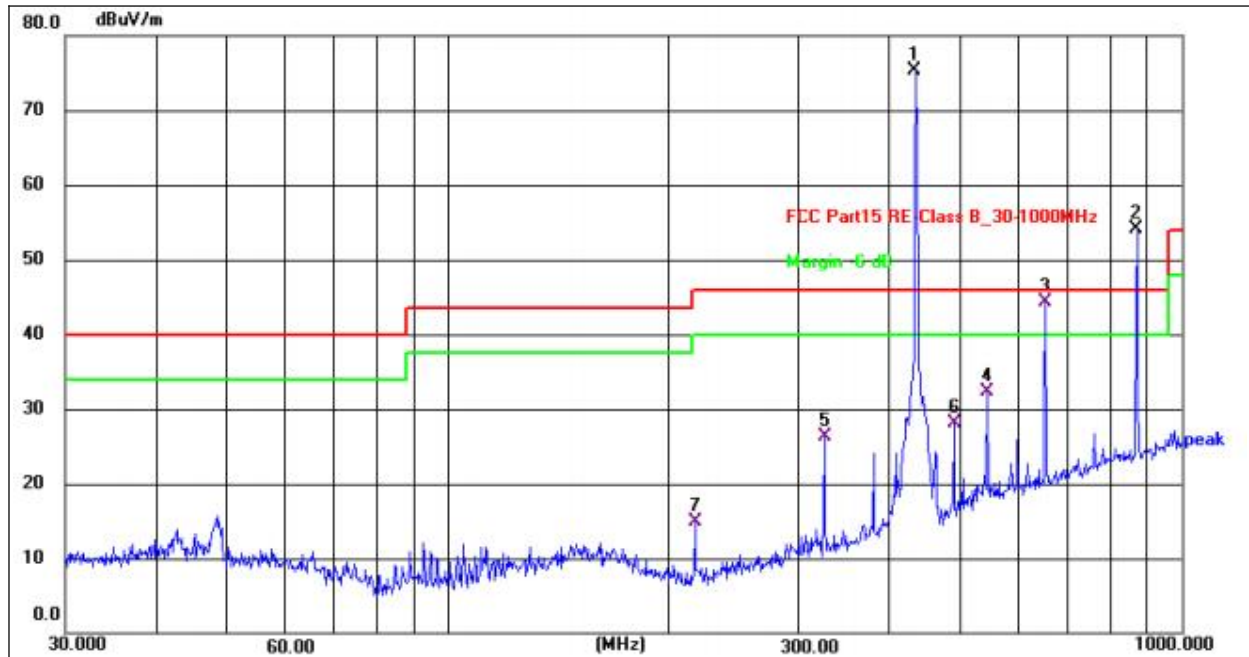

| No. | Frequency (MHz) | Reading (dBuV) | Factor (dB/m) | Level (dBuV/m) | Limit (dBuV/m) | Margin (dB) | Detector |
|-----|-----------------|----------------|---------------|----------------|----------------|-------------|----------|
| 1 * | 433.9200 | 87.66 | -12.29 | 75.37 | 100.8 | -25.43 | peak |
| 2 X | 867.8400 | 58.12 | -4.05 | 54.07 | 80.8 | -26.73 | peak |
| 3 ! | 651.9415 | 52.10 | -7.71 | 44.39 | 46.00 | -1.61 | QP |
| 4 | 543.2740 | 42.16 | -9.89 | 32.27 | 46.00 | -13.73 | QP |
| 5 | 325.5957 | 41.58 | -15.34 | 26.24 | 46.00 | -19.76 | QP |
| 6 | 489.0267 | 39.18 | -11.09 | 28.09 | 46.00 | -17.91 | QP |
| 7 | 216.7828 | 34.23 | -19.23 | 15.00 | 46.00 | -31.00 | QP |

Remarks:

- 1.Final Level =Receiver Read level + Antenna Factor + Cable Loss – Preamplifier Factor
- 2.The emission levels of other frequencies are very lower than the limit and not show in test report.

For average Emission

| Frequency MHz | Peak Level dBuV/m | Duty cycle factor | AverageLevel el dBuV/m | Limit AV | Margin | Polarization |
|------------------|-------------------------|-------------------------|------------------------------|-------------|--------|--------------|
| 433.92 | 72.97 | -8.31 | 64.66 | 80.8 | -16.14 | Horizontal |
| 867.84 | 60.15 | -8.31 | 51.84 | 60.8 | -8.96 | Horizontal |

Notes: 1. Average emission Level = Peak Level + Duty cycle factor
2. Duty cycle level please see clause 6.

| Frequency MHz | Peak Level dBuV/m | Duty cycle factor | AverageLevel dBuV/m | Limit AV | Margin | Polarization |
|------------------|-------------------------|-------------------------|------------------------|-------------|--------|--------------|
| 433.92 | 75.37 | -8.31 | 67.06 | 80.8 | -13.74 | Vertical |
| 867.84 | 54.07 | -8.31 | 45.76 | 60.8 | -15.04 | Vertical |

Notes: 1. Average emission Level = Peak Level + Duty cycle factor
2. Duty cycle level please see clause 6.

Radiated Spurious Emission (1GHz to 10th harmonics)

| Frequency | Receiver Reading | Detector | Turn table Angle | RX Antenna | | Corrected Factor | Corrected Amplitude | FCC Part 15.231/209/205 | |
|-----------|------------------|-------------|------------------|------------|-------|------------------|---------------------|-------------------------|--------|
| | | | | Height | Polar | | | Limit | Margin |
| (MHz) | (dB μ V) | (PK/QP/Ave) | Degree | (m) | (H/V) | (dB/m) | (dB μ V/m) | (dB μ V/m) | (dB) |
| 1816.80 | 49.53 | PK | 345 | 1.5 | H | -14.38 | 35.15 | 74.00 | -38.85 |
| 1816.80 | 49.62 | PK | 84 | 1.9 | V | -14.38 | 35.24 | 74.00 | -38.76 |
| 2725.20 | 47.51 | PK | 131 | 1.1 | H | -12.87 | 34.64 | 74.00 | -39.36 |
| 2725.20 | 47.16 | PK | 133 | 1.2 | V | -12.87 | 34.29 | 74.00 | -39.71 |

| Frequency | PK | Turn table Angle | RX Antenna | | Duty cycle Factor | AV | FCC Part 15.231/209/205 | |
|-----------|----------------|------------------|------------|-------|-------------------|----------------|-------------------------|--------|
| | | | Height | Polar | | | Limit | Margin |
| (MHz) | (dB μ V/m) | Degree | (m) | (H/V) | (dB) | (dB μ V/m) | (dB μ V/m) | (dB) |
| 1816.80 | 35.15 | 79 | 1.4 | H | -8.31 | 26.84 | 54.00 | -27.16 |
| 1816.80 | 35.24 | 316 | 1.3 | V | -8.31 | 26.93 | 54.00 | -27.07 |
| 2725.20 | 34.64 | 325 | 1.7 | H | -8.31 | 26.33 | 54.00 | -27.67 |
| 2725.20 | 34.29 | 159 | 1.0 | V | -8.31 | 25.98 | 54.00 | -28.02 |

Other emissions for frequency above 1GHz are attenuated 30dB below the limit, so it does not reported.

Notes: 1.Average emission Level = Peak Level + Duty cycle factor

2.Duty cycle level please see clause 6.

5. BANDWIDTH TEST

5.1 APPLIED PROCEDURES / LIMIT

According to FCC 15.231(c) requirement:

The bandwidth of the emission shall be no wider than 0.25% of the center frequency for devices operating between 70 MHz to 900 MHz. Those devices operating above 900 MHz, the emission spurious shall be no wider than 0.5% of the center frequency. Bandwidth is determined at the points 20 dB down from the modulated carrier.

$$\text{B.W (20dBc) Limit} = 0.25\% * f(\text{MHz}) = 0.25\% * 433.92\text{MHz} = 1.0848\text{MHz}$$

| Spectrum Parameter | Setting |
|--------------------|---|
| Attenuation | Auto |
| Span Frequency | > Measurement Bandwidth or Channel Separation |
| RB | 1-5%OBW |
| VB | ≥RBW |
| Detector | Peak |
| Trace | Max Hold |
| Sweep Time | Auto |

5.2 TEST PROCEDURE

- The EUT was directly connected to the spectrum analyzer and antenna output port as show in the block diagram below,
- Spectrum Setting : RBW= 1-5%OBW, VBW_≥ RBW, Sweep time = Auto.

5.3 DEVIATION FROM STANDARD

No deviation.

5.4 TEST SETUP



5.5 EUT OPERATION CONDITIONS

The EUT tested system was configured as the statements of 2.4 Unless otherwise a special operating condition is specified in the follows during the testing.

5.6 TEST RESULTS

| | | | |
|---------------|---------|---------------------|-------|
| Temperature : | 26 °C | Relative Humidity : | 54% |
| Pressure : | 101kPa | Test Voltage : | DC 3V |
| Test Mode : | TX Mode | | |

| Frequency | 20dB Bandwidth (kHz) | Limit (MHz) | Result |
|-----------|----------------------|-------------|--------|
| 433.92MHz | 5.101 | 1.0848 | PASS |



6. CALCULATION OF AVERAGE FACTOR

The output field strengths of specification in accordance with the FCC rules specify measurements with an average detector. During the test, a spectrum analyzer incorporating a peak detector was used. Therefore, a reduction factor can be applied to the resultant peak signal level and compared to the limit for measurement instrumentation incorporating an average detector.

The duty cycle is measured in 100 ms or the repetition cycle period, whichever is a shorter time frame. The duty cycle is measured by placing the spectrum analyzer to set zero span at 1000kHz resolution bandwidth.

Averaging factor in dB = $20\log(\text{duty cycle})$

The duration of one cycle = 51.61ms

The duty cycle is simply the on-time divided the duration of one cycle

$$\text{Duty Cycle} = (1.288\text{ms} \cdot 9 + 0.5152\text{ms} \cdot 16) / 51.61$$

$$= 19.8352\text{ms} / 51.61\text{ms}$$

$$= 0.384$$

Therefore, the averaging factor is found by $20\log 0.410 = -8.31\text{dB}$

Test plot as follows:

Note: During the 100ms, the amount of pulse and on-time of pulse are the same for every pulse train.

Cycle



On-time 1



On-time 2

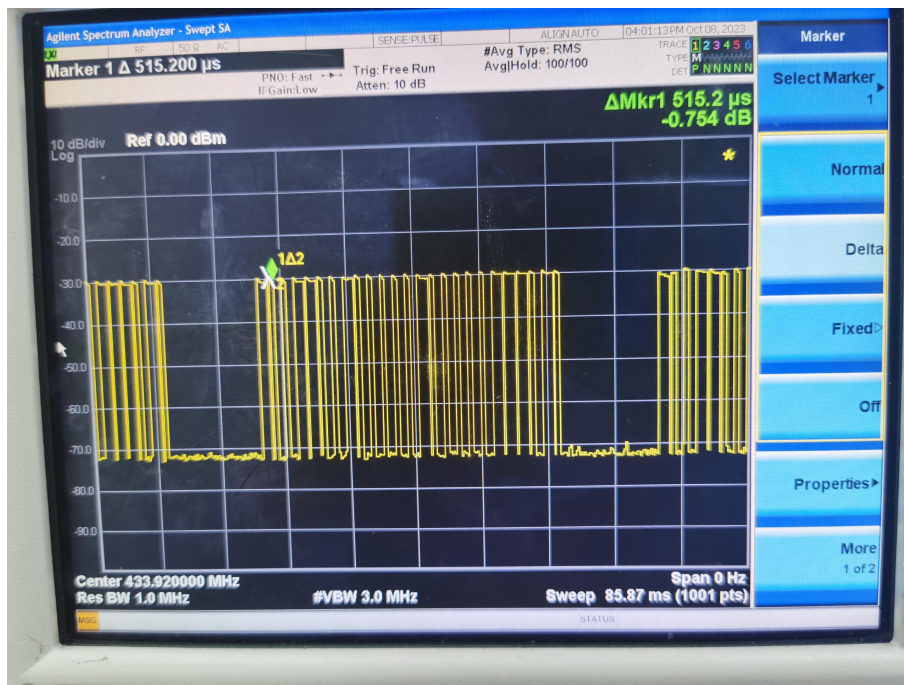

7. DWELL TIME

7.1 APPLICABLE STANDARD

According to FCC 15.231(a) requirement:

A manually operated transmitter shall employ a switch that will automatically deactivate the transmitter within not more than 5 seconds of being released.

7.2 TEST PROCEDURE

Check the calibration of the measuring instrument using either an internal calibrator or a known signal from an external generator.

- 1.Position the EUT without connection to measurement instrument. Turn on the EUT and connect its antenna terminal to measurement instrument via a low loss cable. Then set it to any one measured frequency within its operating range, and make sure the instrument is operated in its linear range.
- 2.Set RBW to 100 kHz and VBW of spectrum analyzer to 300 kHz with a convenient frequency span including 100 kHz bandwidth from band edge.
- 3.Measure the highest amplitude appearing on spectral display and set it as a reference level. Plot the graph with marking the highest point and edge frequency.
- 4.Repeat above procedures until all measured frequencies were complete.

7.3 DEVIATION FROM STANDARD

No deviation.

7.4 TEST SETUP



7.5 EUT OPERATION CONDITIONS

The EUT tested system was configured as the statements of 2.4 Unless otherwise a special operating condition is specified in the follows during the testing.

7.6 TEST RESULTS

| Dwell time (second) | Limit (second) | Result |
|---------------------|----------------|--------|
| 250ms | <5s | Pass |

Test plot as follows:

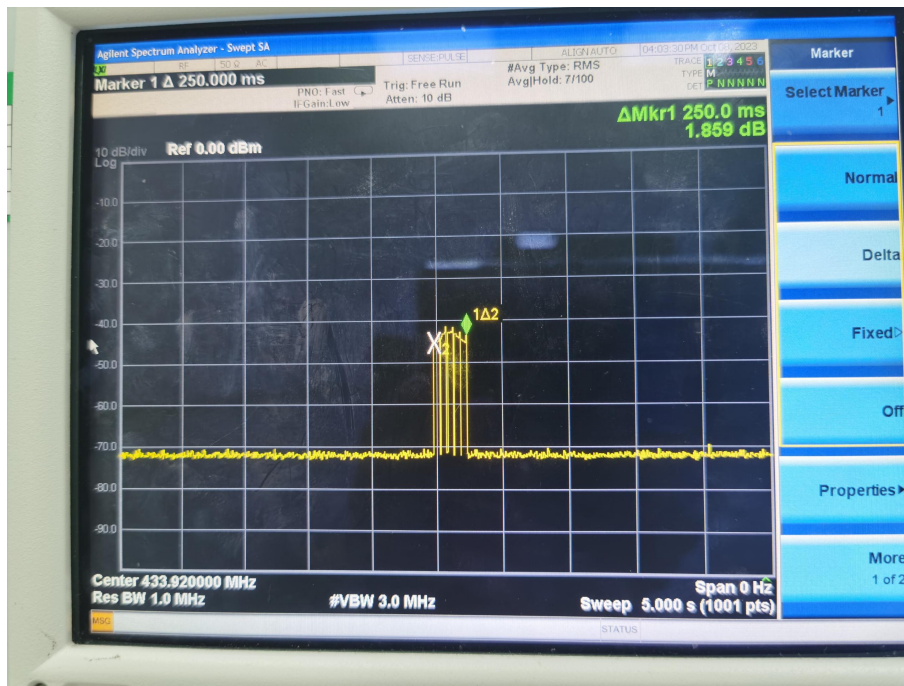

8. ANTENNA REQUIREMENT

| | |
|---|-----------------------------|
| Standard requirement: | FCC Part15 C Section 15.203 |
| 15.203 requirement: An intentional radiator shall be designed to ensure that no antenna other than that furnished by the responsible party shall be used with the device. The use of a permanently attached antenna or of an antenna that uses a unique coupling to the intentional radiator, the manufacturer may design the unit so that a broken antenna can be replaced by the user, but the use of a standard antenna jack or electrical connector is prohibited. | |
| EUT Antenna: | |
| The antenna is PCB Antenna, the best case gain of the antennas are 0dBi, reference to the appendix II for details | |

9. TEST SETUP PHOTO

Reference to the appendix I for details.

10. EUT CONSTRUCTIONAL DETAILS

Reference to the appendix II for details.

******* END OF REPORT *******