

POPFIT

Treadmill

WALKING MACHINE P1

Model No: N4014

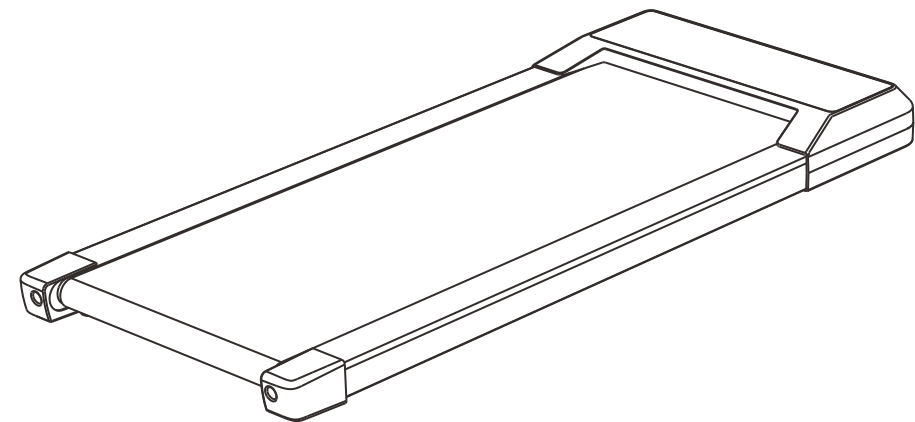

IMPORTANT: Read all instructions carefully before using this product. Retain this owner's manual for future reference.

The specifications of this product may vary from this photo, subject to change without notice.

BRANDS: POPFIT INC

Address: 16192 COASTAL HWY LEWES SUSSEX DE 19958



MADE IN CHINA

User Manual

Please read this manual carefully before using the product and keep it properly for future reference.



Content

- I. Safety Precautions, Warning Notes.....2
- II. Product Description.....6
- III. Installation Procedure.....8
- IV. Sports Suggestions and Policies.....9
- V. Operating Instructions.....11
- VI. FAQ.....12
- VII. Maintenance.....13
- VIII. Service Commitment Warranty.....15

I. Safety Precautions, Warning Notes

Note: Please read the instructions carefully before using the machine and pay attention to the following safety precautions:

It is recommended to place the treadmill indoors to avoid moisture. Do not splash the treadmill or place any foreign matters on it.

- ◆ Please wear appropriate sportswear and sports shoes before exercise. It is strictly prohibited to exercise barefoot on the treadmill and ensure full stretch. The power plug must be reliably grounded, and the socket must have a special loop to avoid sharing with other electrical equipment.
- ◆ Please keep children away from the machine to avoid accidents.
- ◆ Please avoid overloading the product to avoid damage to the motor and controller, accelerating the wear and tear of bearing, running belt and running plate, and regular maintenance.
- ◆ Please reduce the indoor dust, keep the humidity, and avoid generating strong static electricity disturbing the normal operation of the meter and controller.
- ◆ Please turn off the treadmill power after the exercise.
- ◆ Please keep indoor air circulation when using the treadmill.
- ◆ Please stop exercising when you feel uncomfortable or abnormal, and consult a doctor.
- ◆ Please store the silicone oil in a place out of the reach of children after use to avoid accidents due to ingestion.
The safety area behind the treadmill is 1000x2000mm.
Emergency jump off: please hold the handrail with both hands to support your body, while stepping on the sidebar, jump off from the side of the treadmill.

WARNING: Please observe the following regulations to reduce accidents or injuries:

- ◆ Please check whether the clothes are fastened or zipped up before using the treadmill.
- ◆ Please do not wear clothes that are easily caught by the treadmill.
- ◆ Please do not place the power cord near hot objects. Keep children away from the treadmill.
- ◆ Please do not use the treadmill outdoors.
- ◆ Please cut off the power before moving the treadmill.
The upper shield and left and right rear tailstock can only be opened by professional staff. Only one person can exercise on the treadmill when the machine starts. When you feel dizzy, chest pain, nausea or shortness of breath during exercise, please stop exercising immediately and consult your fitness instructor.

Warning! Mandatory!

Please be sure to use it only after discussing with a specialist when receiving medical treatment or for the following patients.

- (1) Patients who are currently suffering from back pain or who have had injuries to their legs, back or neck in the past, or who have numbness in their legs, back, neck or hands (those with herniated discs, spondylolisthesis, cervical spondylosis, etc.).
 - (2) People with deformed arthritis, rheumatism and gout.
 - (3) People with osteoporosis and other abnormalities.
 - (4) People with circulatory system disorders (heart disease, vascular disorders, hypertension, etc.).
 - (5) People with respiratory disorders.
 - (6) Those who are using artificial rhythm regulators or implantable medical electronic instruments.
 - (7) People with malignant tumors.
 - (8) People with blood circulation disorders such as thromboembolism or serious lipoma, acute lipoma, or various skin infections.
 - (9) People with perceptual impairment caused by high peripheral circulation disorder caused by diabetes, etc.
 - (10) People with skin injuries.
 - (11) People with high fever due to illness (38 ° C or above).
 - (12) People with abnormal or bent back bones.
 - (13) People who are pregnant or may be pregnant or are in menstruation.
 - (14) People who feel abnormal and need to rest.
 - (15) People with obvious poor physical condition.
 - (16) Users for rehabilitation purposes.
 - (17) People who feel particularly abnormal except for the above.
—May cause accidents or poor physical conditions.
- ◆ When you feel low back pain, numbness of legs and feet, dizziness, heartbeat and other abnormalities during exercise, please stop using and consult the doctor.
 - ◆ Don't let children use this product or play around it.
—To avoid injury
 - ◆ The protector of children should be careful not to let children play with this product.
—To avoid injury

Forbidden!

- ◆ Please make sure that there are no people or pets around (at the back, bottom and front of the product) during use or when loading, unloading and sliding the product.

Safety Precautions, Warning Notes 04

- ◆ Do not jump up or down during exercise.
—— To avoid injury due to falls.
- ◆ Please do not use it or keep it in damp places such as outdoors and near bathrooms, or in places where you may be exposed to water.
- ◆ Please do not use or keep it in direct sunlight, high-temperature places such as around the stove, or on heating appliances such as electric heating carpets.
—— To avoid electric leakage or fire
- ◆ Do not use it when the power cord or power plug is damaged or the plug of the socket is loose.
—— To avoid electric shock, short circuit and fire.
- ◆ Do not damage or forcibly bend or twist the power cord, or place heavy objects on it to prevent the cord from being clamped.
—— To avoid fire or electric shock.
- ◆ Do not use it by two or more people at the same time, and do not let people around get close to it during use.
—— To avoid accidents or injuries due to falls.
- ◆ Do not allow operators who cannot express their awareness to use this product.

Do not disassemble!

- To avoid accidents or injuries.
- ◆ Absolutely no disassembly, repair, modification
—— To avoid injury due to mechanical failure.

No contact with water!

- ◆ The main body or operating part shall not be exposed to water or other conductive liquids.
—— To avoid electric shock and fire.

Forbidden!

- ◆ It is recommended that people who lack exercise at ordinary times should not suddenly take strenuous exercise.
- ◆ Do not use it after eating, when you are tired, just finished exercising, or when you are not physically strong.
—— To avoid damage to health.
- ◆ This product is only suitable for families and should not be used by a large number of unspecified users such as schools and gyms.
—— To avoid injury.
- ◆ Do not use it while eating or doing other activities.
- ◆ Do not use it when you are feeling dull after drinking.
—— To avoid accidents or injuries.

Safety Precautions, Warning Notes 05

- ◆ Do not use it when the pants are filled with hard objects.
—— To avoid accidents or injuries.
- ◆ Do not attach pins, garbage or impurities to the power plug.
—— To avoid electric shock, short circuit and fire.
- ◆ Do not unplug the power plug or switch the power switch to "OFF" during use.
—— To avoid injury.

Do not use with wet hands!!

- ◆ Do not pull out or insert the power plug with wet hands.
—— To avoid electric shock and injury.

Unplug the power plug!

- ◆ Please unplug the power plug from the socket when it is not in use.
—— Dust and moisture will degrade the insulation, causing electric leakage or fire.
- ◆ Please unplug the power plug from the socket during maintenance.
—— To avoid electric shock or injury.
- ◆ Please stop using the product when it is not started or abnormal, and immediately pull out the power plug and entrust a professional for maintenance.
—— To avoid electric shock or injury.
- ◆ Please pull out the power plug when the power is cut off.
—— To avoid accidents or injuries when power is restored.
- ◆ Please do not pull the wire to pull out the power plug.
—— To avoid short circuits, electric shock and fire.

Grounding instructions!

- ◆ The product must be grounded. When the machine functions abnormally, grounding will provide the current with the most resistant channel to reduce the risk of electric shock.
- ◆ The product is equipped with wires with equipment grounding conductors and grounding plugs. The plug must be plugged into a properly installed and grounded socket in full accordance with local laws and regulations.

DANGER!

- ◆ Improper connection of equipment grounding conductor may cause electric shock. When you have doubts about whether the grounding of the product is correct, please entrust a professional electrician to check. Even if the plug attached to the product does not match the socket, it cannot be modified. Please entrust a professional electrician to install the appropriate socket. The product is equipped with a grounding plug. Please confirm that the product is connected to the appropriate socket. The product can not use the conversion socket.

II. Product Description

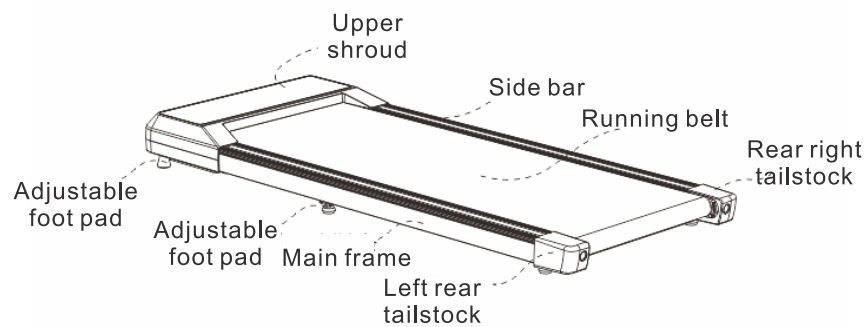

Packing list:

No	Name	Qty.	Remarks
1	Treadmill	1	
2	Accessory box	1	See attached table

Technical parameters:

Working voltage	AC 110V
Maximum load	265lbs
Overall dimensions	48.5*20.7*4 inch
Running area	40*16 inch
Motor peak power	2.5 HP
Speed	0.6-3.8 mph
Control mode	Remote control

Attached table (list of accessory boxes):

No.	Name	Qty.	Remarks
1	5mm inner hexagonal wrench	1	Parts installation
2	6mm inner hexagonal wrench	1	Running belt adjustment
3	Foot pad	2	Balance adjustment
4	Methyl silicone oil	2	Methyl silicone oil
5	Dull wrench	1	Internal disassembly of treadmill
6	Power cord	1	
7	Remote control	1	
8	Manual and certificates	1	

III. Adjustment of Foot Pad Installation

Foot pad installation

1. Turn the treadmill sideways and screw the foot pads into the screw holes as shown in the figure below, screw the two foot pads into the screw holes as shown on the right, tighten clockwise and loosen counterclockwise.

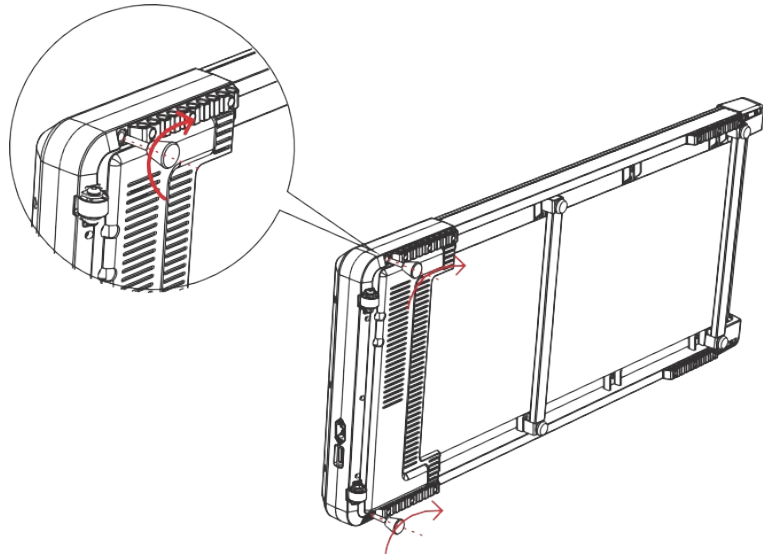

2. Foot pad adjustment: If the ground is uneven or the treadmill is shaking, please adjust the four adjustable foot pads at the bottom of the treadmill to appropriate positions, the foot pads must fit the ground. (As shown below)

By adjusting the foot pad, the slope of the running platform can be raised or lowered.

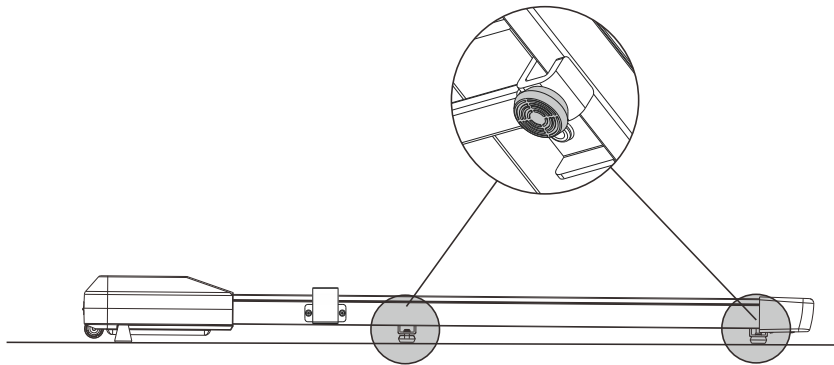

IV. Sports Suggestions and Policies

Warm up

Please warm up for 5-10 minutes before each exercise.

Breathing

Do not hold your breath during exercise. It is recommended that you inhale with your nose and exhale with your mouth when you are ready to restore. Breathing and movement should be coordinated. If you breathe too fast, you should stop exercising immediately.

Frequency

The training of muscles in the same part should have a 48-hour rest, that is the same part can be trained every other day.

Load

Please determine the amount of training according to your physical condition, and then practice according to the principle of gradual progress. Muscle soreness is a normal phenomenon at the beginning of training, and can be eliminated as long as you continue to practice.

Relax

Please do 5 minutes of release action after each exercise, especially the stretching and relaxation of the foot muscles, so as to prevent the muscle from clotting and maintain the muscle elasticity.

Diet

Please take exercise one hour after meals to protect your digestive system; Do not eat until half an hour after exercise. Drink less water during exercise. Do not drink too much water to avoid increasing the burden on the heart and kidneys.

Stretching Exercise

No matter how fast you exercise, please do stretching exercises first. Warm muscles are easier to stretch, so please walk for 5-10 minutes to warm up. Then stop and stretch for 5 times as follows, 10 seconds or more for each leg; Do it again after the exercise.

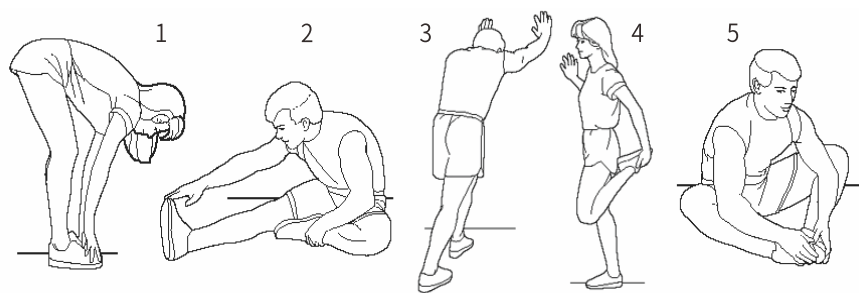
**1. Stretch down**

Bend your knees slightly, bend forward slowly, relax your back and shoulders, and touch your toes with your hands as much as possible. Hold for 10-15 seconds, then relax. Repeat 3 times (see Fig. 1).

2. Hamstring stretch

Sit on a clean cushion, straighten one leg and pull the other leg inward to make it close to the inner side of the straight leg. Try to touch your toes with your hands. Hold for 10-15 seconds, then relax. Repeat 3 times for each leg (see Fig. 2)

3. Calf and heel tendon stretch

Stand on the wall or tree with both hands, one foot behind, keep the back leg upright and the foot following the ground, and lean towards the wall or tree. Hold for 10-15 seconds, then relax. Repeat 3 times for each leg (see Fig. 3).

4. Quadriceps stretch

Hold the wall or table with your left hand to maintain balance, then extend your right hand backward to grasp your right ankle and slowly pull it towards your hip until you feel the muscles in front of your thigh are tense. Hold for 10-15 seconds, then relax. Repeat 3 times for each leg (see Fig. 4).

5. Sartorius muscle (muscle inside leg) stretch

Keep the soles of your feet facing each other and sit with your knees out. Grasp your feet and pull them toward your groin. Hold for 10-15 seconds, then relax. Repeat 3 times (see Fig. 5).

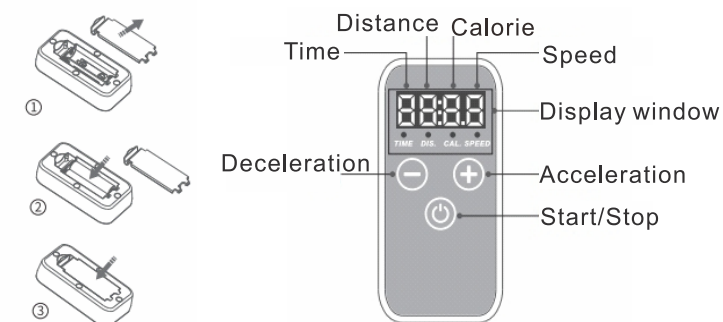
V. Operation instructions**Remote control battery installation and button instructions**

The following functions are displayed in the remote control window: time, speed, distance, and calorie data are displayed in the window in turn. Time display range: 0:00-99:59 Speed display range: 0.6-3.8 MPH Calorie display range: 0.00-9999 Distance display range: 0.00-99.99

Remote control pairing method

1. With the batteries installed in the remote control, press the "Start/Stop" button for 3 seconds to display "-", then press and hold the "+" and "-" buttons simultaneously to display the "┆" to search for treadmill pairing;
2. When the remote control screen displays the "┆" symbol for searching, turn on the treadmill power (5 seconds after turning on the machine) for pairing and hear the "tick" sound from the electronic meter to indicate successful pairing, and the remote control screen displays "0.00".

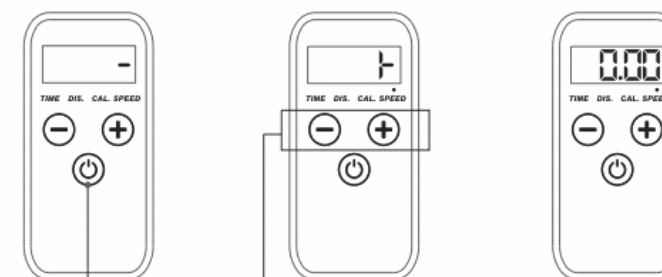

1. Press and hold the "Start/Stop" button for 3 seconds, and the screen displays "-"

2. Press and hold "+" and "-" button at the same time

3. Display "0.00" to complete pairing

Remote Control Functions

- A. Start/Stop: Press this button in the stop state to start the motor. Press this button in the running state, and the treadmill will slow down and stop running.
- B. Deceleration "-": press this button to reduce the speed during operation.
- C. Acceleration "+": press this button to increase the speed during operation.
- D. When the remote controller is not paired successfully, turn it off for 1 minute. After the remote control is paired successfully, the screen will automatically stop for 3 minutes without any operation.
- E. The system will shut down automatically for 30 minutes without any operation after the remote control is paired successfully.

VI. FAQ

Please contact the dealers or our after-sales service for any questions.

Failure	Causes	Maintenance method
The treadmill doesn't work	No power supply	Insert the plug into the socket
	Power is not turned on	Set the power switch to the ON position
	The safety lock is not inserted	Insert the safety lock into the lock position
	Circuit signal system short circuit	Check the controller output terminal and signal line
	Burn fuse	Replace fuse
Running belt doesn't run smoothly	Insufficient lubrication	Add methyl silicone oil lubricant
	Tight running belt	Adjust the running belt
Running belt slipping	Loose running belt	Adjust the running belt
	Loose belt	Adjust the belt

Error message display and troubleshooting

Failure	Causes	Maintenance method
E01	Poor communication	Reconnect the signal cable
E02	Check whether the motor wire is loose or falling off, and whether the carbon brush is worn out	Check whether the motor wire is loose or falling off. If it does not fall off, check whether the carbon brush of the motor is worn out. If it is worn out, replace the motor. If it is not worn out, replace the electric control.
E03	No sensing signal	Reconnect the induction wire
E04	Abnormal controller or motor	Replace the controller and motor when the load is too large
E05	Overload protection	Replace the electric control when the load is too large
E06	System self-test failed	Replace the electric control in case of system failure
Abnormal display	External interference	Turn off the power switch, and then turn on the power for operation after 1 minute

VII. Maintenance

Proper maintenance will help keep your treadmill in the best condition. Improper maintenance will damage or shorten the service life of the treadmill.

- a. Regular inspection is required due to wear and damage; Worn or damaged accessories, such as motor, electric control, power cord, and running belt, are safe to use after professional maintenance.
- b. Please replace the defective parts immediately or reduce the idle of the equipment until it is repaired; (such as power cord)
- c. Pay special attention to the most easily worn components; (such as running belt)
- d. Please have the power cord replaced by the manufacturer, its maintenance department or similar department when it is damaged to avoid danger.

1. Lubrication

The running belt must be lubricated with methyl silicone oil specially configured after a period of use.

Suggestion:

- ◆ When the treadmill is used for less than 3 hours a week, it is recommended to lubricate it once every 5 months.
- ◆ When the treadmill is used for 4~7 hours every week, it is recommended to lubricate it once every 2 months.
- ◆ When the treadmill is used for more than 7 hours every week, it is recommended to lubricate it once a month.

Please lubricate the product with proper lubricant.

Remember: reasonable lubrication is an important factor to improve the life of the treadmill.

2. When checking whether lubricant is needed, please grab the running belt and touch the center of the back of the running belt with your hand as far as possible. If your hand is stained with silicone (a little damp), it means that you do not need to add lubricant. If the running board is dry and there is no methyl silicone oil in it, you need to add lubricant.

- ◆ Steps of applying lubricant to the running board: (as shown in the right figure)
- ◆ Stop the running belt and fold the machine;
- ◆ Lift the running belt at the bottom of the host; Extend the oil pot as far as possible to the middle of the running belt, spray methyl silicone oil on the inner side of the running belt, and apply both methyl silicone oil;
- ◆ Run the treadmill at the speed of 1km/H to evenly apply methyl silicone oil, and gently step on the running belt from left to right, which can make methyl silicone oil completely absorbed by the running belt for about minutes.

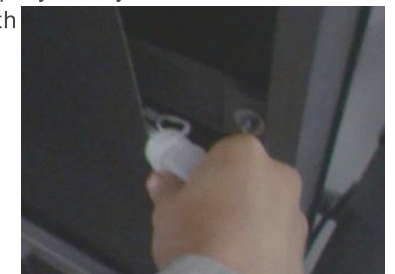

3. Running belt adjustment:

All treadmills shall be adjusted in the running belt .

before and after installation, but they may still loose after a period of use.

If the user stops and slips during running, adjust the adjusting bolts of the running belt clockwise in half a circle. If the running belt is too loose, the running belt and the roller will slip, but if it is too tight, it will easily increase the load of the motor and damage the motor, running belt and roller.

4. Running belt deviation adjustment:

All treadmills shall be adjusted in the running belt before and after installation. However, deviation may still occur after the running period. The causes are as follows:

- ① The treadmill is placed unevenly.
- ② The user's feet are not in the center of during exercise.
- ③ Uneven strength of the legs.

The deviation phenomenon caused by human can be restored to normal after idling for a minute. For the deviation phenomenon that cannot be restored to normal, a 6mm hex wrench can be used to adjust it in half a circle.

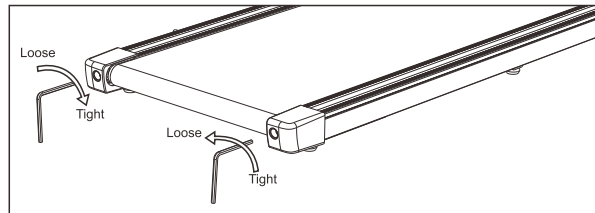

When the running belt deviates to the left, adjust the left bolt clockwise or adjust the right bolt counter-clockwise.

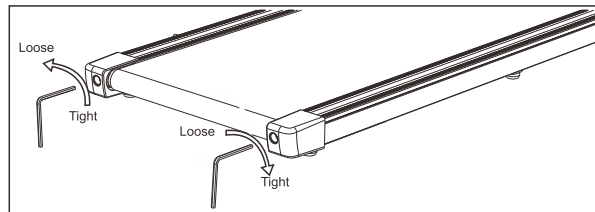

When the running belt deviates to the right, adjust the right bolt clockwise or adjust the left bolt counter-clockwise.

Prompt: The running belt deviation is not within the scope of warranty, and can be maintained by the user according to the manual. The running belt deviation will seriously damage the running belt, and it must be found and corrected in time.

VIII. Service Commitment Warranty

IMPORTANT: FOR POPFIT ONLY

For damaged or defective products, questions, replacement parts or any other service support, please contact our customer service department by the below methods:

For The Best Service, Email us with order ID at:

POPFIT.US@outlook.com

PLEASE DO NOT RETURN THE PRODUCT DIRECTLY WITHOUT ASKING OUR CUSTOMER SERVICE FIRST.

99% OF OUR CUSTOMERS BELIEVE THAT THEY GET SATISFACTORY SOLUTIONS BY CONTACTING US BEFORE RETURN.

We will reply to you within 24 hours and solve your problem as soon as we can.

MANUFACTURERS LIMITED WARRANTY

POPFIT warrants to the original purchaser that this product is free from defects material and workman-conditions that it has been installed and operated in accordance with POPFIT Owner's Manual.

POPFIT's obligation under this warranty applies to the following:

COMPONENT LENGTH OF WARRANTY

Structural Frame 1 year For Home Use Only

All Other Components 90 days For Home Use Only

EXCLUSIONS FROM WARRANTY COVERAGE

POPFIT does not warrant against and is not responsible for, and no implied warranty shall be deemed to cover, any product failure, product malfunction, or damages attributable to:

1. Improper installation and/or failure to abide by POPFIT's installation guidelines;
2. Use of this product beyond normal home use, or in an application for which it was not designed;

Service Commitment Warranty 16

3. Cosmetic items such as scratches, dents or discolorations;
4. Damage caused by normal wear and tear, vandalism, accidental or by animals;
5. Any act of Nature (such as fire, flooding, snow, ice, hurricane, earthquake, lightning or other natural disasters), environmental condition (such as air pollution, mold, mildew, etc.), or staining from foreign substances (such as dirt grease, oil etc.).
6. Normal weathering due to exposure to sunlight, weather and atmosphere which can cause colored surfaces to among other things, flake, chalk, accumulate dirt or stains.
7. Improper operation and handling, alteration, storage, abuse or neglect of the products.

POPFIT, using its sole discretion, will either repair or replace free of charge any parts proven to be defective under normal home use, any repair or replacement shall provide no new warranty coverage, but shall retain only the remaining portion of the original product's warranty. This warranty is offered only to the original purchaser and is not transferable. Proof of original purchase is required.

When ordering replacement parts please have the following information ready:

1. **Order Number**
2. **Description of Parts (Add photos or videos would be helpful)**
3. **Part Number**
4. **Date of purchase**

FCC WARNING

This device complies with part 15 of the FCC Rules. Operation is subject to the following two conditions: (1) this device may not cause harmful interference, and (2) this device must accept any interference received, including interference that may cause undesired operation.

Any changes or modifications not expressly approved by the party responsible for compliance could void the user's authority to operate the equipment.

NOTE: This equipment has been tested and found to comply with the limits for a Class B digital device, pursuant to Part 15 of the FCC Rules. These limits are designed to provide reasonable protection against harmful interference in a residential installation. This equipment generates, uses and can radiate radio frequency energy and, if not installed and used in accordance with the instructions, may cause harmful interference to radio communications. However, there is no guarantee that interference will not occur in a particular installation.

Service Commitment Warranty 17

If this equipment does cause harmful interference to radio or television reception, which can be determined by turning the equipment off and on, the user is encouraged to try to correct the interference by one or more of the following measures:

- Reorient or relocate the receiving antenna.
- Increase the separation between the equipment and receiver.
- Connect the equipment into an outlet on a circuit different from that to which the receiver is connected.
- Consult the dealer or an experienced radio/TV technician for help.

To maintain compliance with FCC's RF Exposure guidelines, This equipment should be installed and operated with minimum distance between 20cm the radiator your body: Use only the supplied antenna.