

Product Instruction Manual

WALKING TREADMILL PLUS

Model NO: N4225

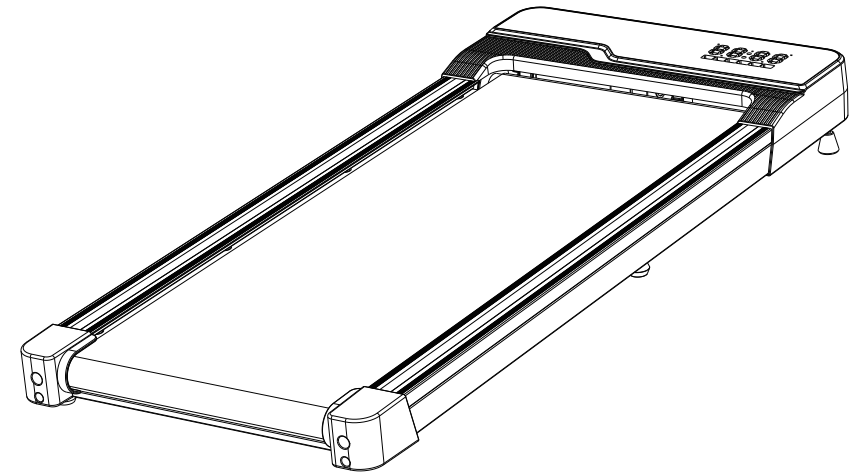

 Please read the instructions carefully before using.

Table of contents

- 1. Safety Precautions & Warning Instructions----- 02
- 2. Product Introduction----- 06
- 3. Setup and Storage Instructions -----08
- 4. Exercise Recommendations and Guidelines ----- 09
- 5. Operation Instructions ----- 11
- 6. Common Malfunctions and Troubleshooting -----14
- 7. Product Maintenance-----15
- 8. Service Commitment -----16
- 9. FCC Statement -----18

1. Safety Precautions and Warning Instructions

Note: Please read the instruction manual carefully before use and pay attention to the following safety precautions.

- ★ The walking treadmill should be placed in a well-ventilated and dry indoor area to avoid moisture. Do not place any foreign objects on the walking treadmill to prevent motor damage due to water entering the motor.
- ★ Before starting exercise, ensure you are wearing appropriate sportswear and professional sports shoes, and perform full-body stretching activities. Do not exercise barefoot on the walking treadmill.
- ★ The power plug must be securely grounded, and the socket used should have a dedicated circuit to avoid sharing power with other electrical devices.
- ★ Keep children away from this equipment to prevent accidents.
- ★ Avoid prolonged operation of the walking treadmill under overload conditions, as this may lead to damage to the motor and controller, accelerating wear and aging of bearings, running belts, and the deck. Regular maintenance is recommended to ensure the equipment is in good condition.
- ★ To maintain the normal operation of electronic instruments and controllers, reduce indoor dust, and maintain appropriate indoor humidity to prevent strong electrostatic interference.
- ★ After use, be sure to turn off the power of the walking treadmill.
- ★ Maintain indoor air circulation while using the walking treadmill.
- ★ If you feel discomfort or experience abnormal conditions during exercise, stop immediately and consult a medical professional.
- ★ After using silicone oil, store it in a place inaccessible to children to avoid serious consequences in case of accidental ingestion.
- ★ The safety area behind the walking treadmill is 39.37*78.74inch.
- ★ Avoid placing the walking treadmill on a carpet, as this may reduce ventilation and cooling efficiency, leading to potential motor burnt out.
- ★ Do not place the walking treadmill on uneven floors, as this may cause imbalance during use and damage the walking treadmill.

Warning: To reduce accidents, please follow these regulations.

- ★ Before using the walking treadmill, check if clothing is properly fastened or zipped up.
- ★ Avoid wearing items that may be caught by the walking treadmill.
- ★ Keep the power cord away from heat sources.
- ★ Prevent children from approaching the walking treadmill.
- ★ Do not use the walking treadmill outdoors.
- ★ Disconnect the power before moving the walking treadmill.
- ★ Do not open the upper cover and left and right rear seats without professional supervise.
- ★ Restricted to one person exercising on the walking treadmill.
- ★ If you feel dizziness, chest pain, nausea, or shortness of breath during exercise, stop immediately and consult a medical professional.

Warning! Mandatory!

When you are undergoing medical treatment or belong to the following patient types, be sure to consult a professional doctor before using.

- (1) Patients experiencing lower back pain or those who have suffered injuries to the legs, lower back, or neck, or those experiencing pain in the legs, lower back, neck, and arms (such as chronic patients with disc herniation, spinal slippage, cervical protrusion, etc.).
 - (2) Patients with osteoarthritis, rheumatism, or painful rheumatism.
 - (3) Individuals with abnormalities such as osteoporosis.
 - (4) Individuals with circulatory system diseases (heart disease, vascular disease, high blood pressure, etc.).
 - (5) Individuals with respiratory organ disorders.
 - (6) Individuals using artificial pacemakers or implanted medical electronic devices.
 - (7) Individuals with malignant tumors.
 - (8) Individuals with thrombosis or severe blood circulation disorders, acute venous inflammation, etc.
 - (9) Individuals with peripheral circulation disorders caused by conditions such as diabetes.
 - (10) Individuals with skin wounds.
 - (11) Individuals with fever due to diseases (skin temperature reaching 38°C or above).
 - (12) Individuals with abnormal or bent backs.
 - (13) Pregnant or potentially pregnant women, or women in menstruation.
 - (14) Individuals feeling physically abnormal and in need of rest.
 - (15) Individuals with obvious poor physical condition.
 - (16) Individuals using the equipment for rehabilitation purposes.
 - (17) Individuals who feel any abnormality in their body other than the above situations.
 - Use may cause accidents or worsening of physical condition.
- ◆ If you experience unusual pain, such as lower back pain, leg numbness, dizziness, abnormal heartbeat, or a sense of discomfort different from usual during exercise, stop immediately and consult a medical professional.
 - ◆ Supervisors of children should be careful not to let them play around this product.
 - ◆ Non-compliance with this regulation may result in injury.
 - ◆ During use or when loading and unloading the product, ensure that there are no people or pets around (rear, bottom, front of the product).

Prohibited!

- ◆ Do not use this device if the housing is cracked, broken, or detached (exposing internal structures) or if welded parts are detached.
 - Otherwise, accidents or injuries may occur.
- ◆ Do not jump on or off the walking treadmill during exercise.
 - Doing so may cause falls and injuries.
- ◆ Do not use or store the walking treadmill outdoors, in the bathroom, or in damp or easily wet places.
- ◆ Do not place the walking treadmill in direct sunlight or in a high-temperature environment, such as around a fireplace or on heating devices such as electric blankets.
 - Otherwise, electrical leakage or fire may occur.

- ◆ If the power cord or power plug is damaged or the socket is loose, do not use the walking treadmill.
 - Otherwise, electric shock, short circuit, or fire may occur.
- ◆ Do not damage, bend, or twist the power cord. Also, avoid placing heavy objects on the power cord or pinching the wire.
 - Otherwise, leakage or fire may occur, or even electric shock, short circuit.
- ◆ Do not let two or more people use the walking treadmill simultaneously, and be mindful of the absence of others around during use.
 - Otherwise, accidents or injuries may occur.
- ◆ Do not allow individuals who cannot express their consciousness or operate the walking treadmill independently to use it.
 - This may result in accidents or injuries.

Do not disassemble the walking treadmill!

- ◆ Absolutely prohibited to disassemble, repair the walking treadmill, or replace the walking treadmill's components.
 - There is a risk of injury due to mechanical failure.

Avoid contact with water!

- ◆ Do not allow the main body or control components to come into contact with water or other conductive liquids.
 - This may result in electric shock or fire.

Prohibited!

- ◆ People who do not exercise regularly should not engage in strenuous exercise suddenly.
 - This may cause harm to health.
- ◆ Do not use after drinking water, feeling fatigued, during the early stages of exercise, or when the body is in an abnormal condition.
 - This may lead to injury.
- ◆ This product is suitable for home use and is not suitable for places with multiple non-specific users, such as schools or gyms.
- ◆ Do not use during drinking, eating, or other activities.
- ◆ Do not use when feeling sluggish after drinking.
 - This may cause accidents or injuries.
- ◆ Do not use with hard objects in the pockets of pants.
 - This may cause accidents or injuries.
- ◆ Do not allow needles, garbage, or water to attach to the power plug.
 - This may cause electric shock, short circuit, or fire.
- ◆ Do not pull out the power plug or switch the power switch to "off" during use.
 - This may cause injury.

Caution with wet hands!

- ◆ Do not pull out or insert the power plug with wet hands.
- This may cause electric shock and injury.

Pull out the power plug!

- ◆ When the equipment is not in use, pull out the power plug from the socket.
- Dust and humid air may cause insulation degradation, leading to electrical leakage or fire.
- ◆ When maintaining, be sure to pull out the power plug from the socket.
- Non-compliance may result in electric shock or injury.
- ◆ When the equipment cannot start or abnormalities occur, stop using it. Immediately pull out the power plug, and entrust a professional to inspect and repair.
- Non-compliance may result in electric shock or injury.
- ◆ During a power outage, pull out the power plug immediately.
- Otherwise, there may be accidents or injuries when power is restored.
- ◆ When pulling out the power plug, do not pull the wire portion; grip the plug to pull it out.
- Otherwise, short circuits, electric shock, or fire may occur.

Grounding instructions!

- ◆ This product requires grounding. If the equipment malfunctions, grounding will provide the minimum resistance path for current, reducing the risk of electric shock.
- ◆ The product is equipped with a wire for grounding the device and a grounding plug. This plug must be inserted into a properly installed and grounded socket that fully complies with local regulations or legal requirements.

Danger!

- ◆ Improper connection of the grounding conductor of the device may result in an electric shock hazard. If you have any doubts about the grounding of the product, please entrust a professional electrician for inspection. Even if the plug provided with the equipment does not match the socket, do not modify it.
- Please have a professional electrician install the appropriate socket.
- ◆ This product has a grounding plug. Ensure it is connected to a socket that matches its plug shape.
- This product cannot be plugged to an adapter.

2. Product Introduction

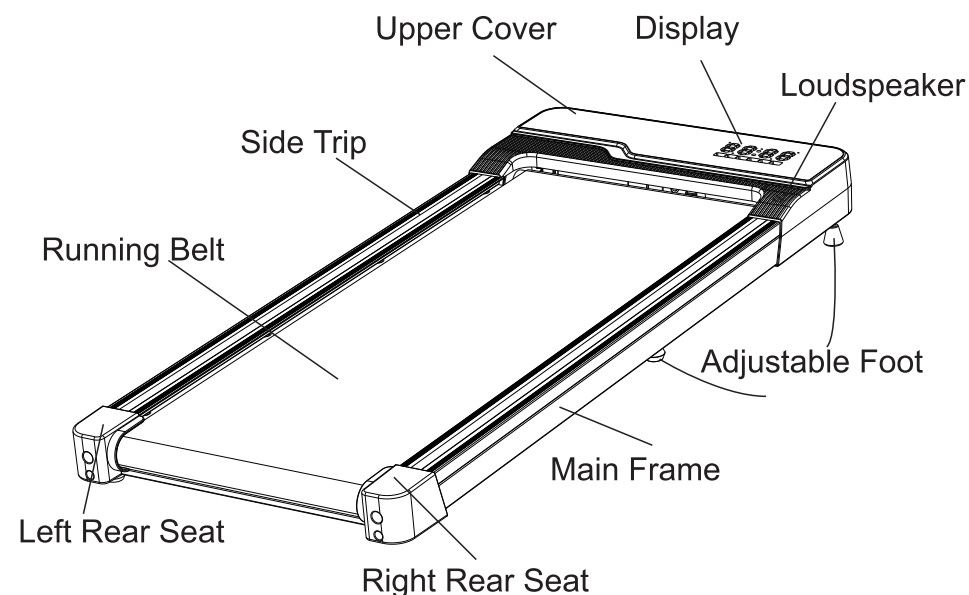

Packing List:

| NO. | Name | Qty. | Remarks |
|-----|---------------------|------|--------------------|
| 1 | Main Unit | 1 | |
| 2 | Spare Parts Package | 1 | See attached table |

Technical Parameters

| | |
|-----------------|---------------------|
| Working Voltage | AC 100-120V 50/60Hz |
| Maximum Load | 265lbs |
| Product Size | 48.78"x21.2"x5" |
| Running Area | 16.5"x40.16" |
| Maximum Power | 2.25HP |
| Displayed Speed | 0.6-3.8mph |
| Control Method | Remote Control |

Attachment (Spare Parts Package List)

| NO. | Name | Qty. | Remarks |
|-----|-----------------------------------|------|----------------|
| 1 | 5# Hex Wrench | 1 | Miscellaneous |
| 2 | 6# Hex Wrench | 1 | Adjusting Belt |
| 3 | Foot Pad | 2 | |
| 4 | Methyl Silicone Oil | 1 | |
| 5 | Dull Wrench | 1 | |
| 6 | Remote Control | 1 | |
| 7 | Instruction Manual, Certification | 1 | |
| 8 | Power Cord | 1 | |

08 Setup and Storage Instructions

3. Setup and Storage Instructions

1. After taking the main unit out of the packaging, place it flat on the floor. As shown in the image below, tighten the foot treadmills clockwise into the screw holes to secure them.

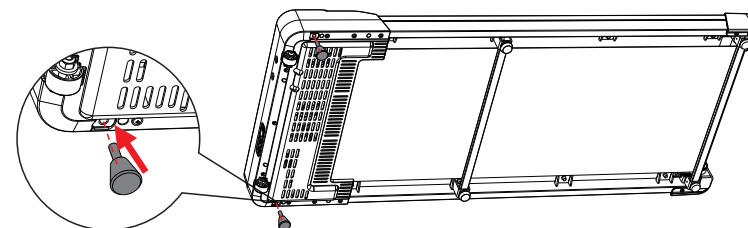

2. In case of uneven ground or walking treadmill shaking, adjust the adjustable foot treadmills at the bottom of the walking treadmill to the appropriate position. The foot treadmills must be flush with the ground. (As shown in the image below)

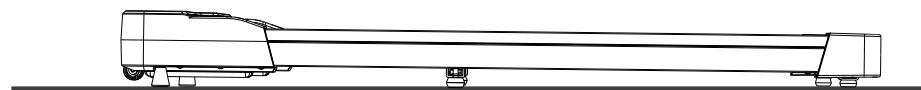

Note: Adjust the slope according to your needs.

3. As shown below, insert the power cord into the front socket of the walking treadmill, turn on the power switch at the bottom front of the machine, and the walking treadmill enters standby mode.

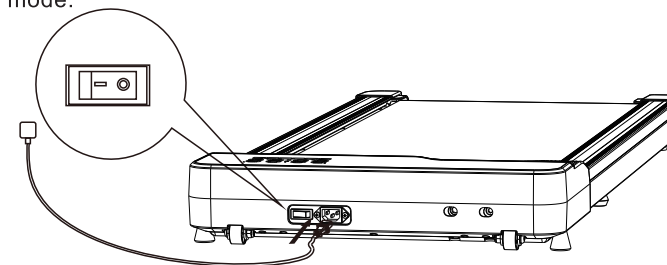

4. To move the walking treadmill, first unplug the power cord, then lift the rear of the walking treadmill by hand, allowing the wheels to move on the ground for forward and backward movement.

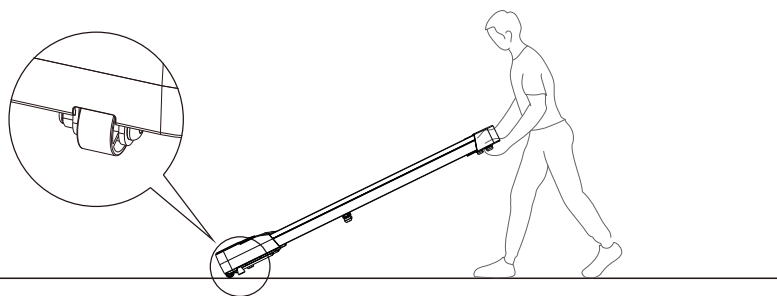

4. Exercise Recommendations and Guidelines

Warm-up

Before each session, a 5-10 minute warm-up is necessary.

Breathing

During exercise, do not hold your breath. Breathe regularly, coordinating with your movements. If breathing becomes too rapid, stop exercising immediately.

Frequency

Training the same muscle group should have a 48-hour rest period, meaning the same muscle group should not be trained on consecutive days.

Training Load

Determine the training load based on personal fitness level, then practice following the principle of progressive load. Muscle soreness is normal in the initial training. With consistent exercise, soreness will gradually subside.

Relaxation

Perform a 5-minute cool-down after each training session, especially stretching and relaxing the muscles in the feet to prevent prolonged tension and maintain muscle elasticity.

Diet and Hydration

It is recommended to exercise at least one hour after a meal, and avoid consuming food immediately after exercise. Drink water sparingly during exercise, especially avoiding large quantities to prevent stress on the heart and kidneys.

Stretching Exercises

It's advisable to start with stretching exercises before using the walking treadmill. Warmed up muscles are more flexible, so spend 5-10 minutes warming up. Before walking, perform the following stretching exercises – 5 times, 10 seconds or more for each leg; repeat this exercise after walking on the walking treadmill.

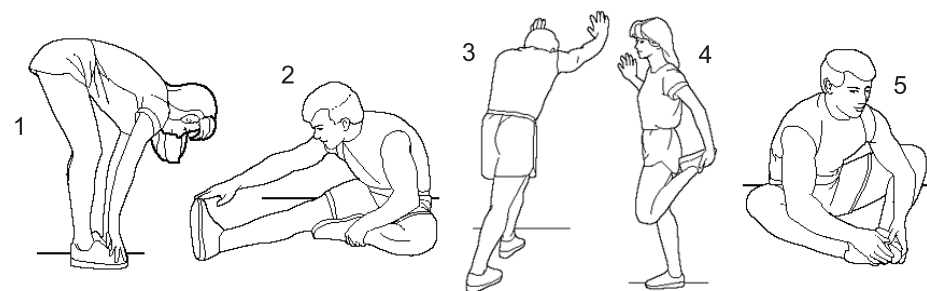

1. Forward Stretch

Bend both knees slightly, lean forward slowly, allowing the back and shoulders to relax. Try to touch your toes with your hands. Hold for 10-15 seconds, then relax. Repeat 3 times (see Figure 1).

2. Achilles Tendon Stretch

Sit on a clean mat with one leg straight. Bring the other leg inward, pressing it against the inner side of the straight leg. Try to touch your toes with your hands. Hold for 10-15 seconds, then relax. Repeat 3 times for each leg (see Figure 2).

3. Calf and Heel Tendon Stretch

Stand with both hands against the wall, with one foot at the back. Keep the back leg straight and the heel on the ground, lean towards the wall. Hold for 10-15 seconds, then relax. Repeat 3 times for each leg (see Figure 3).

4. Quadriceps Stretch

Hold onto the wall or table for balance with the left hand, then extend the right hand backward, grabbing the right ankle and slowly pulling it towards the buttocks until you feel tension in the front of the thigh. Hold for 10-15 seconds, then relax. Repeat 3 times for each leg (see Figure 4).

5. Adductor (Inner Thigh Muscles) Stretch

Feet facing each other, knees outward. Squat down, grabbing both feet and pulling towards the groin. Hold for 10-15 seconds, then relax. Repeat 3 times (see Figure 5).

5. Operation Instructions

Display

The display shows the countdown when starting, displaying "3", "2", "1". During operation, it automatically switches every 5 seconds to different display sections (in sequence: "SPEED", "TIME", "DIST" and "CAL").

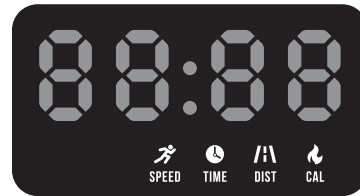

1. During operation, the LED display automatically switches to display these metrics every 5 seconds.
2. In standby state, when there is no operation, the display will be in sleep after 10 minutes, and can be woken up by key, remote control and security lock.

Display Metrics Ranges

| Setting Parameters | Initial Value | Display Range |
|--------------------|---------------|---------------|
| Time (min:sec) | 0:00 | 0:00-99:59 |
| Speed (mph) | 0.6 | 0.6-3.8 |
| Distance (miles) | 0.00 | 0.00-99.99 |
| Calories (kcal) | 0.0 | 0.0-9999 |

Remote Control Pairing Method

Within 5 seconds of powering on the walking treadmill, press and hold the "I▷" button on the remote control. When you hear continuous beeping sounds from the walking treadmill buzzer, it indicates successful pairing. You can then start using the remote control to operate the walking treadmill. Once paired, subsequent usage does not require re-pairing.

Bluetooth Audio Connection

1. In standby mode, open the Bluetooth of your cell phone, search the Bluetooth audio name "Mobvoi WTMP" of this treadmill, then press the "—" key of the remote control, the cell phone will search and display the corresponding Bluetooth name of this treadmill (Mobvoi WTMP), click to connect.
2. After connected to the Bluetooth audio, in standby mode, on your phone press the "—" key of the remote control to disconnect the Bluetooth audio.

Remote Control Functions

1. "Start/Stop": In standby mode, press the "Start/Stop" button on the remote control. The walking treadmill will start a 3-second countdown and operate at a speed of 0.6mph. During exercise, you can press the "Start/Stop" button at any time to stop the motor.

12 Operation Instructions

2. "Speed+": While the walking treadmill is running, a short press on the "+" button on the remote control will gradually increase the speed. A long press will increase the speed rapidly. The speed will continuously increase with an increment of 0.2mph.

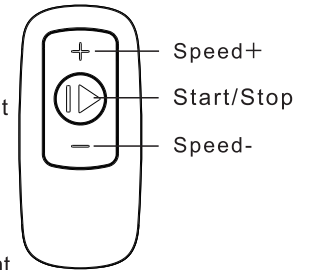

3. "Speed-": While the walking treadmill is running, a short press on the "-" button on the remote control will gradually decrease the speed. A long press will decrease the speed rapidly. The speed will continuously decrease with a decrement of 0.2mph.

Mobvoi Home intelligent experience

Use a smartwatch adopting Wear OS by Google™ and download Mobvoi Treadmill App. Then you can observe the synchronous exercise data and your heart rate both via your smartwatch and our treadmill.

Download and install Mobvoi Treadmill App

- 1) On the watch platform, open Play Store, search for Mobvoi Treadmill, download and install it.
- 2) On the watch platform, open Play Store, search for Mobvoi Account, download and install it.



Mobvoi Treadmill

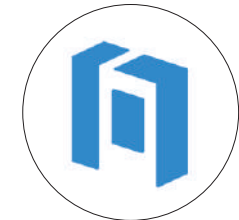

Mobvoi Account

- 3) Sign in your Mobvoi account.
 - a. After installing, open the watch platform and Mobvoi Treadmill App. Choose to log in your Mobvoi account with watch or phone .
 - b. If you have not signed in a Mobvoi account, please choose to log in by phone and finish account registration according to tips.

Experience Mobvoi Treadmill

1) Confirm that the treadmill is turned on with Bluetooth mode, and the Bluetooth function of the smartwatch has been turned on also. Enter the smartwatch Mobvoi Treadmill App, and click "Connect Devices", the treadmill can be automatically paired with the smartwatch and you'll see the successful pairing.

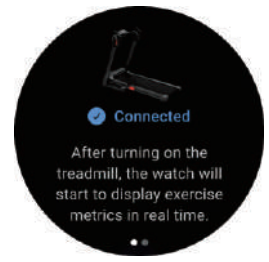

2) After successfully pairing with the smartwatch, when you exercise, you can view heart rate data through the watch's Mobvoi Treadmill App, also the record and real-time data such as exercise time, speed, distance, calories, paces and so on.



3) Check the data during the exercise, and make sure that the treadmill runs at low speed to ensure personal safety.
 4) After the end of the exercise, the smartwatch platform will record and generate the sports record.

Experience Mobvoi App

Wearing a smartwatch while exercising and using the Mobvoi Treadmill App, the smartwatch data can be synced to the mobile Mobvoi App.

- 1) Search for Mobvoi App in the app store, download and install it, and log into your Mobvoi account.
- 2) Click on the "Sports Card" on the home page to view the exercise history from Mobvoi Treadmill App.
- 3) In the Mobile Mobvoi App you can view detailed data record, and you can share your exercise history with others.

6. Common Malfunctions and Troubleshooting

If you have any other questions, please contact the local dealer or our company's after-sales service.

| Issues | Possible Causes | Troubleshooting Steps |
|-------------------------------------|------------------------------------|--|
| Treadmill cannot operate. | Power not connected. | Plug the power cord into the socket. |
| | Power not turned on. | Turn the power switch to the ON position. |
| | Circuit signal system malfunction. | Check the controller input and signal lines. |
| Running belt does not run smoothly. | Insufficient lubrication. | Apply methyl silicone oil lubricant. |
| | Running belt too tight. | Adjust the tightness of the running belt. |
| Treadmill belt slipping. | Running belt slips. | Adjust the tightness of the running belt. |
| | Loose belt. | Adjust the tightness of the running belt. |

Display Error Messages and Solutions

| Fault Codes | Possible Causes | Troubleshooting Steps |
|-----------------------|---|--|
| E01 | Communication abnormality between lower control and electronic board. | Check if the communication cable between the lower control and the electronic board is loose or disconnected. |
| E02 | 1. Motor wires are loose or disconnected. 2. Carbon brushes are worn out or not in contact with the rotor. 3. Lower control is damaged. | Inspect the motor wires for looseness or disconnection. If not disconnected, check if the motor brushes are worn out or not in contact with the rotor. If the motor is normal, the lower control may be damaged. |
| E05 | Overload protection activated. | If there is an overload, exceeding the rated current, turn off the power and restart. |
| Display Abnormalities | External interference. | Turn off the power switch, wait for 1 minute, and then power on and restart. |

7. Product Maintenance

1. Lubrication:

After using the treadmill for a period, it is necessary to lubricate it with the dedicated methyl silicone oil.

Recommendation:

- ★ Weekly usage less than 3 hours Lubricate once every 5 months
- ★ Weekly usage between 4-7 hours Lubricate once every 2 months
- ★ Weekly usage more than 7 hours Lubricate once every 1 month

Remember: Excessive lubrication is not better.

Proper lubrication is a crucial factor in improving the walking pad's lifespan.

2. Checking if Lubrication is Needed:

To check if lubrication is needed, lift the treadmill belt and touch the center of the belt's back with your hand.

If your hand has a slight moist feeling from silicone oil, no lubrication is needed. If the running board is dry and your hand doesn't get any silicone oil, lubrication is required.

- ★ Steps to apply lubricant to the running board (as shown in the right image).
- ★ Stop the walking treadmill running.
- ★ Lift a small portion of the running belt and spray methyl silicone oil on the inner side of the belt, close to the center.
- ★ Run the walking pad at 0.6mph to evenly spread the oil across the running board. Lightly step on the belt from left to right. This process takes a few minutes to ensure complete absorption.

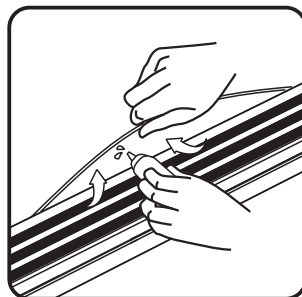

3. Running Belt Tension Adjustment:

All walking pads should be adjusted for running belt tension before out of factory and after setup at home. However, after some usage, the belt may become loose. If users experience a slipping phenomenon while running, the belt needs adjustment. Turn the belt adjustment bolts clockwise, in half-turn increments, synchronously on both sides.

If the treadmill is too loose, when stepping on the running belt, there may be slippage between the running belt and the roller. However, being too tight is not ideal, as it can increase the load on the motor, leading to damage to the motor, running belt, and roller, among other components.

4. Running Belt Deviation Adjustment:

All walking pads should be adjusted for running belt tension before out of factory and after setup at home. However, deviation may still occur after some usage, caused by:

- ① unstable placement;
- ② uneven foot pressure
- ③ uneven force applied by the user with the two feet.

16 Service Commitment

If the running belt is deviated by usage, running without load for a few minutes can restore normal operation. For cases where automatic recovery is not possible, use the provided 6# hex wrench to adjust gradually in half-turn increments.

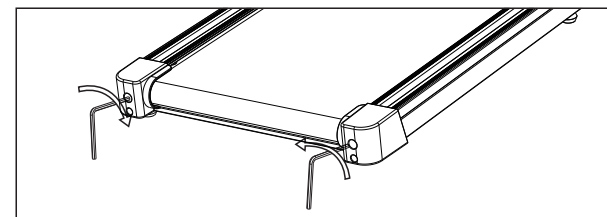

If the belt deviates to the left: Adjust the left bolt clockwise or the right bolt counterclockwise.

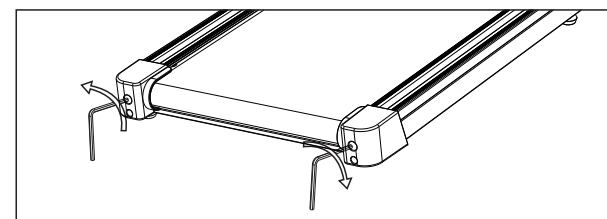

If the belt deviates to the right: Adjust the right bolt clockwise or the left bolt counterclockwise.

Note: Running belt deviation is not covered by the warranty. Users need to perform maintenance according to the instruction manual. Prompt detection and correction are necessary to prevent serious damage.

8. Service Commitment

For the electric walking treadmill, under normal use within one year, we will provide users with free replacement parts for non-human-induced damages. After the warranty period, spare parts will be provided at favorable prices.

This product is intended for home use only. We are not responsible for issues arising from commercial use. For post-sales issues, contact your local dealer's after-sales service.

We provide statutory warranty service in the country where you purchased the product.
Regulatory compliance, full-text Supplier DoC are available on the official website.
Please check out our official website to learn more: www.mobvoi.com/products
Please contact us if you experience any problems. Customer service: support@mobvoi.com
The limited warranty applies for N4225 electric treadmill. Within the warranty period of normal use, such as non-human damage, Mobvoi can provide users with free accessories. After the expiration of the warranty period, preferential prices of spare parts may be offered to previous buyers.
Manufacturer: Jiangxi EQi Industrial Co.,Ltd



This device complies with part 15 of the FCC Rules. Operation is subject to the following two conditions: (1) this device may not cause harmful interference, and

(2) This device must accept any interference received, including interference that may cause undesired operation.

Changes or modifications not expressly approved by the party responsible for compliance could void the user's authority to operate the equipment. This equipment has been tested and found to comply with the limits for a Class B digital device, pursuant to Part 15 of the FCC Rules. These limits are designed to provide reasonable protection against harmful interference in a residential installation. This equipment generates uses and can radiate radio frequency energy and, if not installed and used in accordance with the instructions, may cause harmful interference to radio communications. However, there is no guarantee that interference will not occur in a particular installation. If this equipment does cause harmful interference to radio or television reception, which can be determined by turning the equipment off and on, the user is encouraged to try to correct the interference by one or more of the following measures:

- - Reorient or relocate the receiving antenna.
- - Increase the separation between the equipment and receiver.
- - Connect the equipment into an outlet on a circuit different from that to which the receiver is connected.
- - Consult the dealer or an experienced radio/TV technician for help.ct.

This equipment complies with the FCC RF radiation exposure limits set forth for an uncontrolled environment. This equipment should be installed and operated with a minimum distance of 20cm between the radiator and any part of your body.