

MODEL : S102

Spinning Bike

## OWNER'S MANUAL



Please read carefully before installing and using spinning bike.  
All instructions are in the manual.  
Please keep this manual in a safe place.  
The manual is for reference only, please prevail in kind!

---

## Important Safety Notice

1. Keep children and pets away from the Spin Bike at all times.  
DO NOT leave unattended children in the same room with the machine.
2. Handicapped or disabled persons should not use the Spin Bike without the presence of a qualified health professional or physician.
3. If the user experiences dizziness, nausea, chest pain, or any other abnormal symptoms, STOP the workout at once. CONSULT A PHYSICIAN IMMEDIATELY.
4. Before beginning training, remove all objects within a radius of 2 meters from the machine. DO NOT place any sharp objects around the Spin Bike.
5. Position the Spin Bike on a clear, level surface away from water and moisture. Place mat under the unit to help keep the machine stable and to protect flooring.
6. Use the Spin Bike only for its intended use as described in this manual. DO NOT use any other accessories not recommended by the manufacturer.
7. Assemble the machine exactly as the descriptions in the instruction manual.
8. Check all bolts and other connections before using the machine for the first time and ensure that the trainer is in the safe condition.
9. Hold a routine inspection of the equipment. Pay special attention to components which are the most susceptible to wear off, i.e. connecting points and wheels. The defective components should be replaced immediately. The safety level of this equipment can only be maintained by doing so. Please don't use the Spin Bike until it is repaired well.
10. NEVER operate the Spin Bike if it is not functioning properly.
11. This machine can be used for only one person's training at a time.
12. Do not use abrasive cleaning articles to clean the machine.  
Remove drops of sweat from the machine immediately after finishing training.
13. Always wear appropriate workout clothing when exercising. Running or aerobic shoes are also required.
14. Before exercising, always do stretching first.
15. The power of the machine increases with increasing the speed, and the reverse.  
The machine is equipped with adjustable knob, which can adjust the resistance.
16. This equipment has been tested and certified to EN957 under the H.C. rating and is intended for home and indoor use only.
17. This device is not suitable for use in therapy.
18. Be careful when moving the device to avoid hurting you.
19. Weight on this product should not exceed 120kg

**WARNING:** Before beginning this or any exercise program, consult your doctor. This is especially important for people over the age of 35 or those with pre-existing health problems

## Explosion Drawing

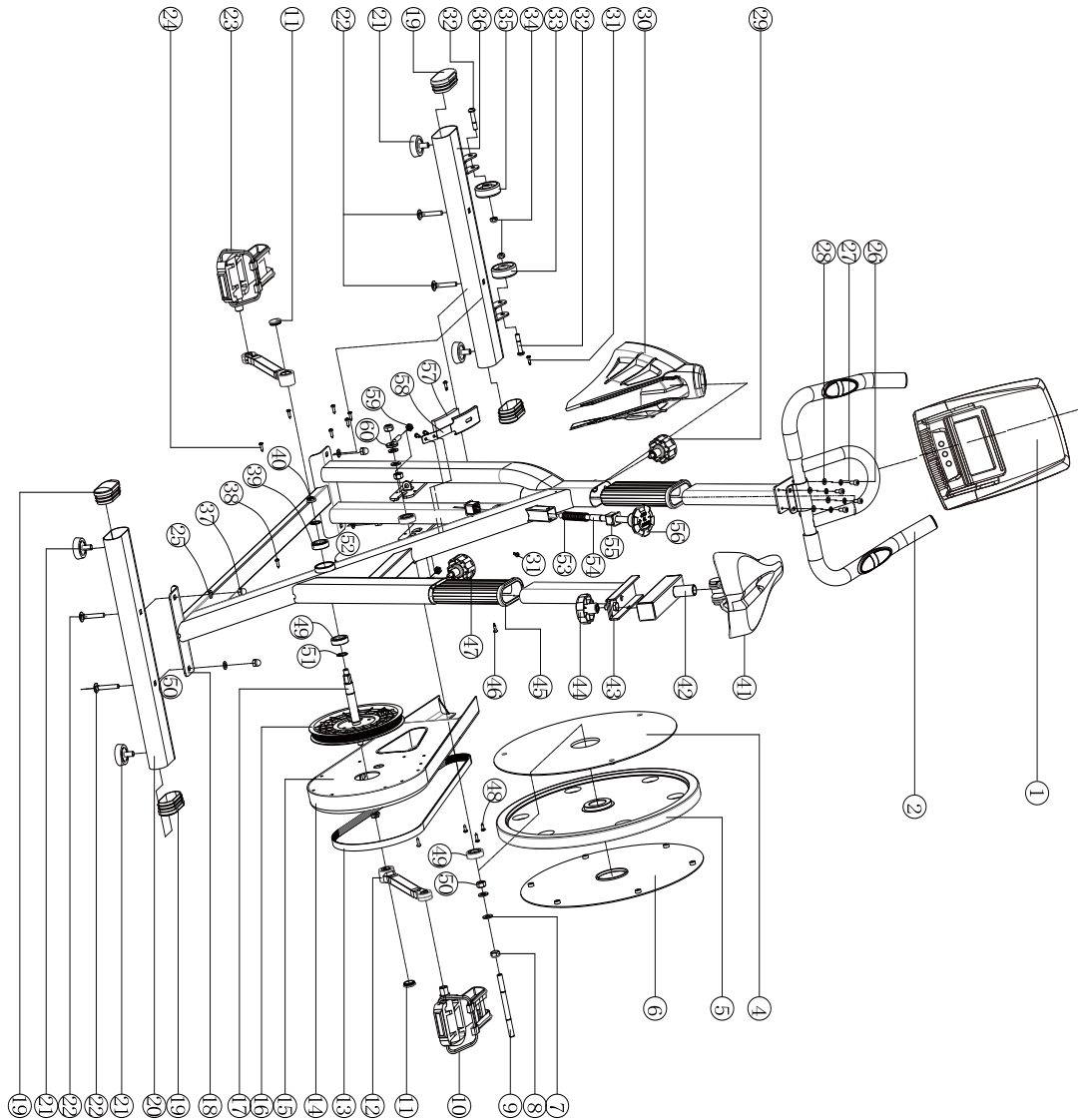

## Explosion Drawing List

No.	Item Name	Qty.	No.	Item Name	Qty.
1	Computer Display	1	25	Flat Washer $\Phi 9 \times \Phi 16 \times 1.5$	2
2	Handlebar Set	1	26	Hexagon socket round cap screw M6×12	4
3			27	Elastic Washer $\Phi 6.7 \times 1.6$	4
4	Flywheel Left Cover	1	28	Flat Washer $\Phi 6.6 \times \Phi 12 \times 1.6$	4
5	Flywheel	1	29	Spring Latch M16×1.5	3
6	Flywheel Right Cover	1	30	Front Fork Cover	1
7	Flat Washers $\Phi 11 \times \Phi 20 \times 2$	7	31	Cross recessed self-drilling self-tapping screws ST4.2×16	9
8	Hexalobular Self-locking Nut M10	1	32	Hexagon Socket Half Tooth Bolt M8×40-15	2
9	M10 Double screw	1	33	Moving wheel	2
10	Right Pedal	1	34	Hexagon Self-locking Nuts M8×13×7.5	4
11	Crank plug	1	35	Moving Wheel	2
12	Right Crank	1	36	Front Foot Tube	1
13	Belt	1	37	Cap nut M8	4
14	Chain Outer Cover	1	38	Cross recessed self-tapping screws ST4.2×19	2
15	Chain Inner Cover	1	39	Deep Groove Ball Bearing 6300RS	2
16	Belt pulley	1	40	Hex Flange Thin nut M10×1.25	2
17	Crankshaft	1	41	Cushion Seat	1
18	Main Frame	1	42	Cushion Vertical Adjustment Welding Sets	1
19	Elliptical tube plug	4	43	Cushion Horizontal Adjustment Welding Sets	1
20	Rear Leg	1	44	M10 Plum Knob	1
21	Adjustable Foot pad	4	45	Reducing sleeve	2
22	Large Half-Round head square neck bolt M8×50	4	46	Cross recessed self-drilling self-tapping screws ST4.2×16	2
23	Left Pedal	1			
24	Cross recessed Self-locking Screws ST4.2×19	2			

No.	Item Name	Qty.
47	Spring Latch M16×1.5	1
48	Cross recessed pan head tapping screws ST4.2×13	2
49	Deep Groove Ball Bearing 6300RZ	2
50	Hex nuts M10×16×9.5	2
51	Shaft circlip Φ17×1.0	2
52	Induction bar	1
53	Braking Pressure Spring	1
54	Brake lever	1

No.	Item Name	Qty.
55	Brake Lever Rubber Cover	2
56	Brake Lever Handle	1
57	Felt	1
58	Brake pad	1
59	Hexalobular Self-locking Nuts M8×13×7.5	2
60	Spring Bots M8×45	1

## Products Information

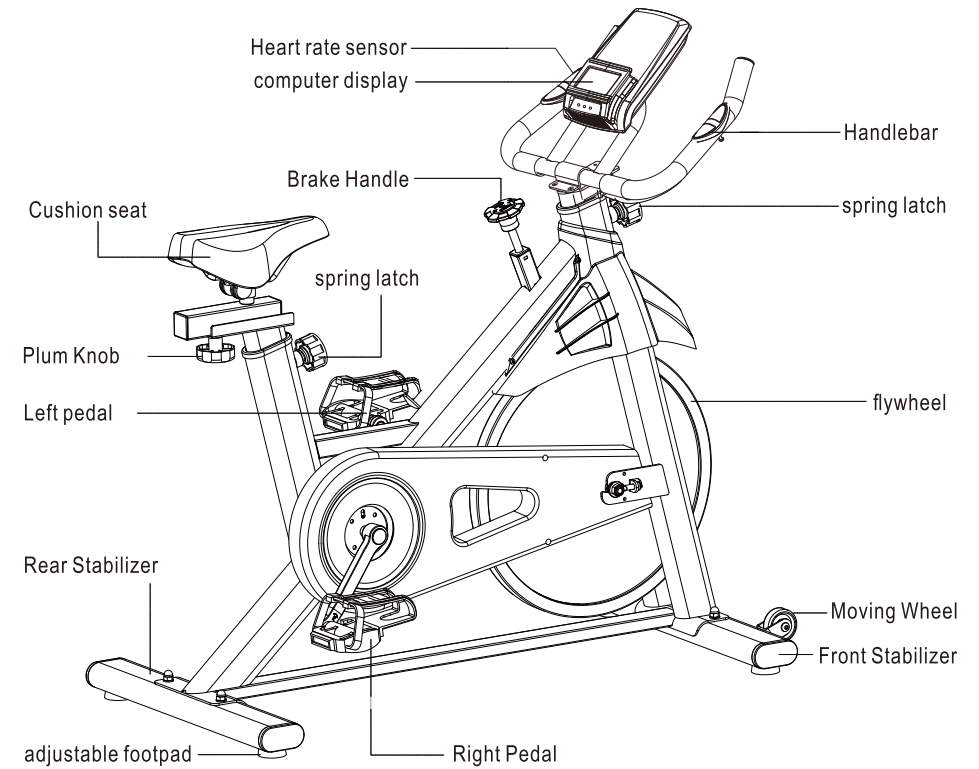

## Technical Para

Max User Weight	120kg	Product Net Weight	25kg
Product Size	Largest: 1042×524×1144 mm	Adjustment Range	handlebar Height Adjustment Range 120mm
			Cushion Horizontal Adjustment Range 60mm
Braking Methods	Friction Braking System		Cushion Vertical Adjustment Range 120mm

## Packing List

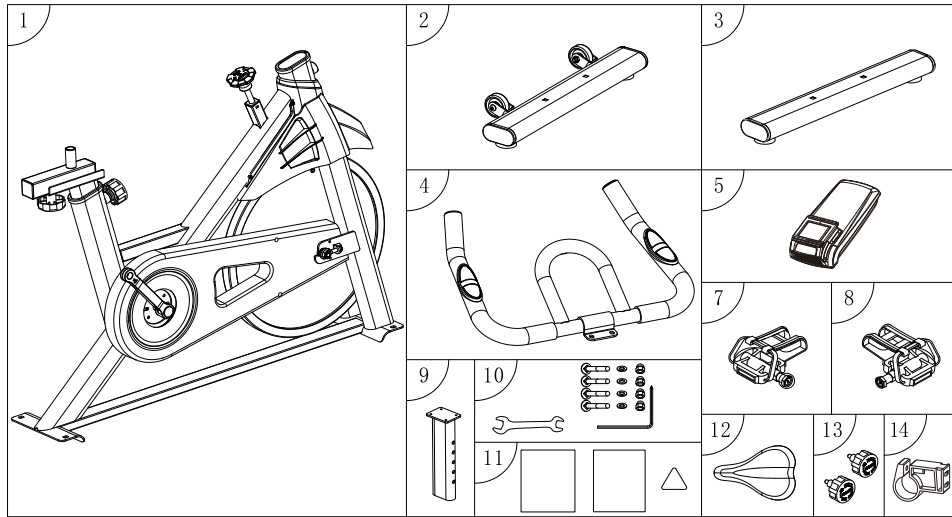

No.	Item Name	Qty.	Notes
1	Main Frame	1	
2	Front Stabilizer	1	
3	Rear Stabilizer	1	
4	Handlebar	1	
5	Computer Display	1	
6	Phone Holder	1	
7	Left Pedal	1	

No.	Item Name	Qty.	Notes
8	Right Pedal	1	
9	Adjustable Tube	1	
10	Spare Parts Bag	1	See Attached Table 1 for reference
11	Documents Bag	1	Manual, warranty card, certificate
12	Cushion seat	1	
13	Spring Latch	2	M16*1.5
14	Electronic watch base	1	

## Attached Table 1

No.	Item Name	Qty.	Notes
1	Hexagon socket head cap screw M6×16	4	Fix the handlebar 4PCS
2	Elastic Washer Φ6.7×1.6	4	Fix the handlebar 4PCS
3	Flat Washer Φ6.6×Φ12×1.6	4	Fix the handlebar 4PCS
4	Large Half-Round Head Square Neck Bolt M8×53	4	Fix the front/rear foot tube sets 4PCS
5	Flat Washer Φ9×Φ16×1.6	4	Fix the front/rear foot tube sets 4PCS
6	Cap Nuts M8	4	Fix the front/rear foot tube sets 4PCS
7	Wrench	1	
8	5#Allen wrench	1	One side is cross head

## Assembly Steps

★ In order to ensure the assembly is completed reasonably and efficiently, please strictly follow the steps described below.

1. As shown in Figure 1, Take the main frame out of the box and stood upright on the floor;

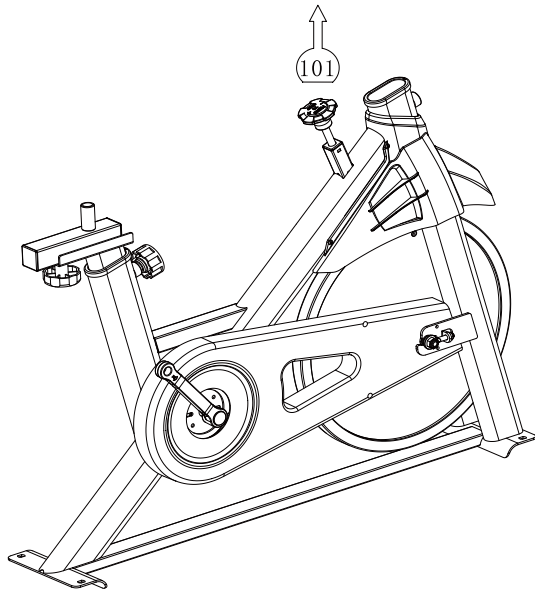

Figure 1

2. As shown in step 202 in Figure 2, insert two "Large Half-Round Head Square Neck Bolt M8x53" into the square hole of the "Front foot tube sets" to pass the arc of the front end of the main body while the carrying wheel is facing forward. The round hole of the shape piece is respectively inserted into the "flat washer  $\Phi 9 \times \Phi 16 \times 1.6$ " and then screwed into the "cap nut M8", and the nut is tightened with a 13# wrench;

As shown in step 203 of Figure 2, two "Large Half-Round Head Square Neck Bolt M8x53" are respectively inserted into the square holes of the "rear foot tube assembly", and the adjustable foot pad is perpendicular to the bottom surface and then passes through the host. The round hole of the curved piece at the front end is respectively inserted into the "flat washer  $\Phi 9 \times \Phi 16 \times 1.6$ " and then screwed into the "cap nut M8", and the nut is tightened with a 13# wrench;

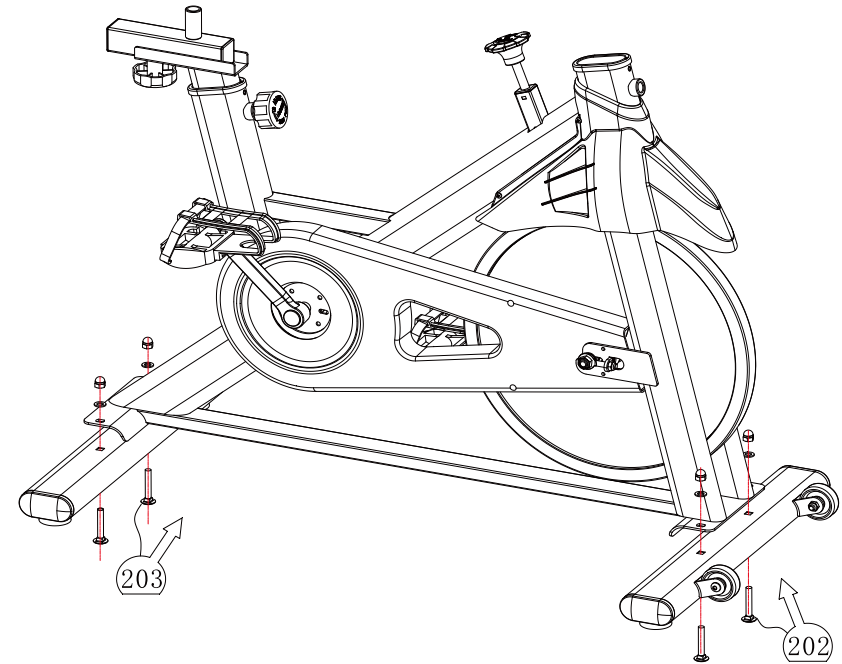

Figure 2

As shown in step 301 of Figure 3, the "spring latch" is screwed into the main frame in the direction shown in the figure;

As shown in step 302 of Figure 3, the adjustable handle tube is inserted into the main frame, and the "spring latch" is automatically pulled into the hole position after being pulled out;

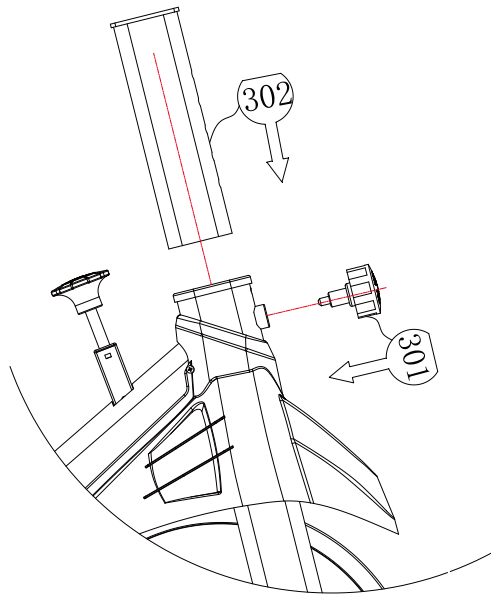

Figure 3

4. As shown in step 401 of Figure 4, align the four mounting holes in the middle of the "handlebar" with the four M6 fixing screw holes on the front end of the "main frame";

As shown in step 402 in Figure 4, four "hexagonal head cap screws M6 x 12" are sequentially inserted into the "elastic washer  $\Phi 6.7 \times 1.6$ " and "flat washer  $\Phi 6.6 \times \Phi 12 \times 1.6$ " and then passed through. Screw the "handle" mounting hole into the front fixing screw hole on the "main frame" and tighten the screw with a "5# hex wrench".

As shown in step 403 of Figure 4, the electronic computer display is inserted into the iron piece of the handrail, and the terminal connection line on the electronic watch is connected;

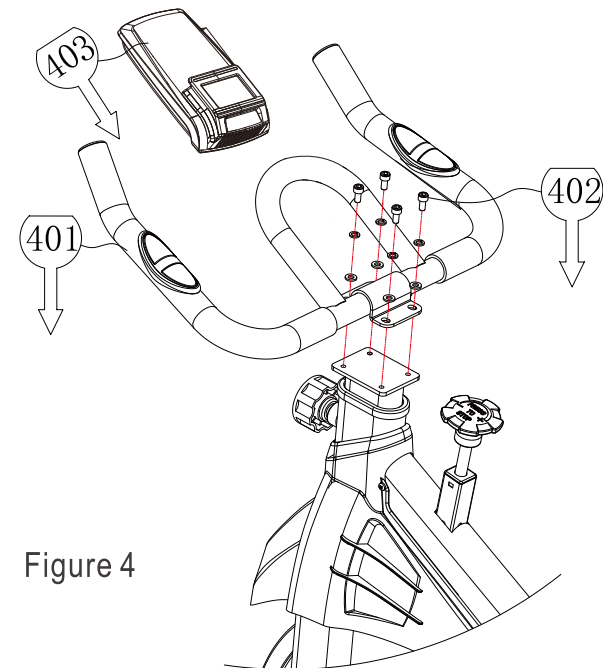

Figure 4



5. As shown in step 501 of Figure 5, screw the left-hand screw of the "left pedal" into the "left crank" screw hole of the "main frame" in a counterclockwise direction, and clamp the "left pedal" screw with a 16 # wrench. Slightly rearward to lock it to the "left pedal".

6. As shown in step 502 in Figure 5, screw the right-handed screw of the "right pedal" into the "right crank" screw hole of the "main frame", and use the 16 # wrench to clamp the "right pedal" screw to the rear position. Lock it to the "right pedal".

7. As shown in step 503 of Figure 5, attach the seat cushion to the seat cushion adjustment tube as shown in the figure, and tighten the screws under the seat cushion with an allen wrench.

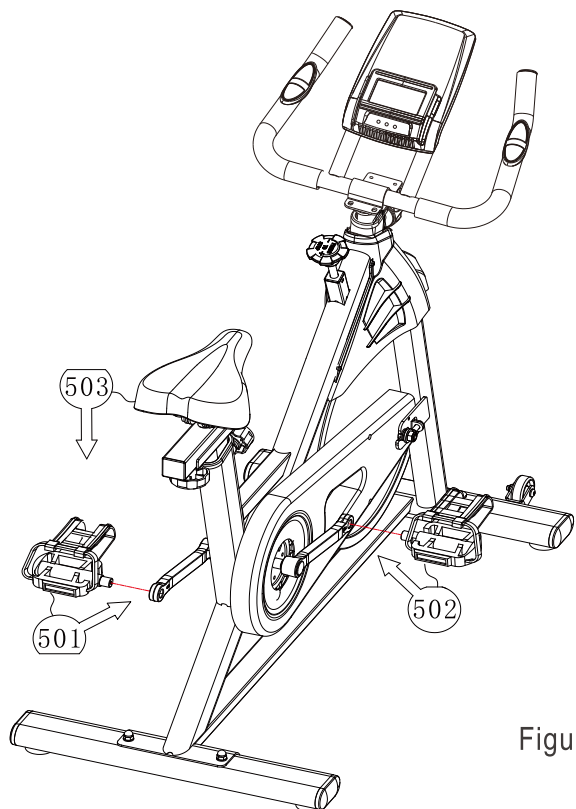

Figure 5

8. As shown in Figure 6, the installation is complete.

note:

After the unit is assembled, check again that all bolts are locked during the installation.

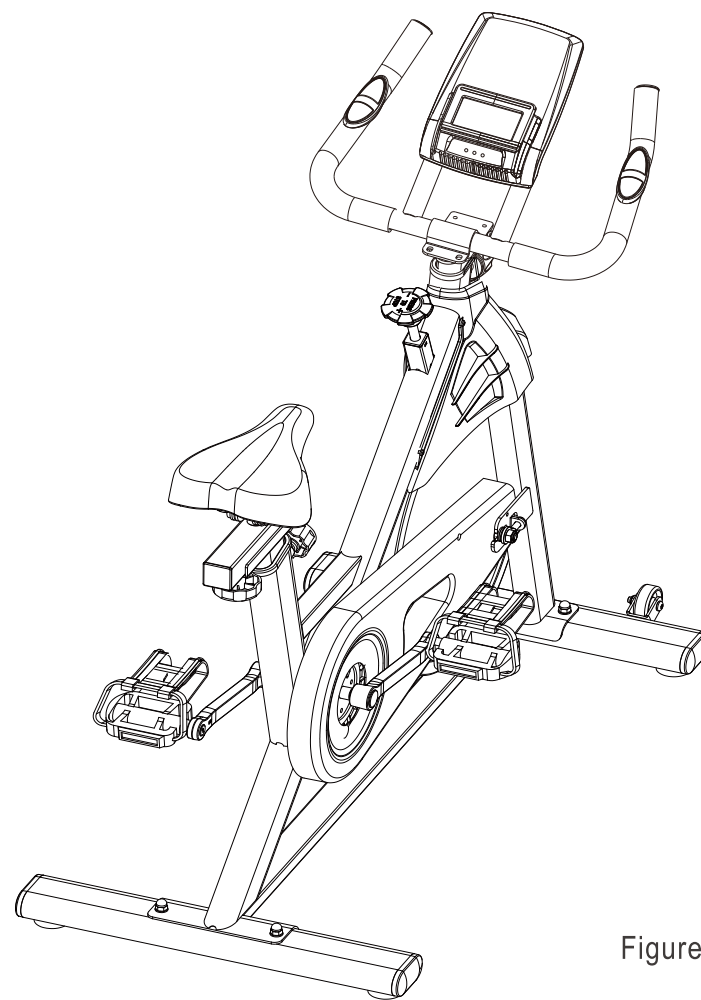
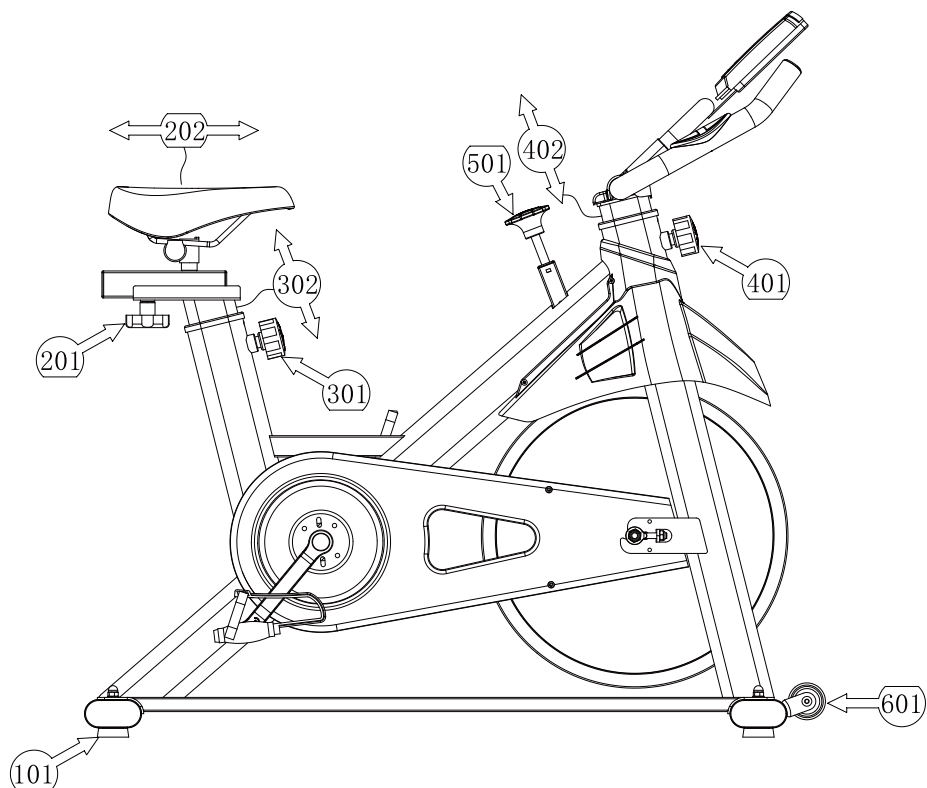

Figure 6



## Operation Guide



### Whole Machine stability Adjustment

When the machine is placed on the ground, if one of the foot pads is not completely close to the ground, we can adjust the foot pad for this case. The adjustment amount is not more than 10 mm. If the adjustment amount is greater than 10 mm, you can adjust the other foot pad diagonally. The specific operation is as follows: When the 101 (screw pad) is screwed counterclockwise by hand, the height of the foot pad can be adjusted.

**Note:** According to the user's height, body shape, etc., the following adjustments can be made to each part of the machine:

### 1. Horizontal adjustment of the seat cushion

First loosen the 201 (Plum Knob) button, slide the seat cushion to the desired position, and then tighten the plum knob.

### 2. Vertical adjustment of the seat cushion

First pull out the 301 (spring latch), then put the 302 (seat adjustment tube) into the desired position, and then release the spring latch to automatically enter the hole.

### 3. Height adjustment of the handlebar

First pull out the 401 (spring latch), then pull the 402 (handle adjustment tube) into the desired position, and then release the spring latch to automatically enter the hole.

### 4. Use of brake handle

When the user needs to brake rapidly during use, the 501 (brake handle) can be directly pressed down, which can directly cause the flywheel to stop rotating in a short time. The time when the flywheel stops depends on the strength of the pressing force.

The user can also rotate the brake handle clockwise, so that the braking system can gradually brake the flywheel. When the action of the brake handle to achieve the effect of increasing the resistance value. Conversely, the effect of reducing the resistance value is achieved.

---

## 5. Machine movement

When the user moves the machine, as shown in Figure 601, the user should stand in front of the machine and face the machine. Both hands grasp the left and right end portions of the handle, and apply an inward pulling force and downward pressure. The back end of the table is tilted up, and after the 602 (moving wheel) touches the ground, it is pressed down a little, so that the machine center can be balanced and then the machine can be pulled or pushed.

### FCC Warning

This device complies with part 15 of the FCC Rules. Operation is subject to the following two conditions: (1) This device may not cause harmful interference, and (2) this device must accept any interference received, including interference that may cause undesired operation.

Note: This equipment has been tested and found to comply with the limits for a Class B digital device, pursuant to part 15 of the FCC Rules. These limits are designed to provide reasonable protection against harmful interference in a residential installation. This equipment generates, uses and can radiate radio frequency energy and, if not installed and used in accordance with the instructions, may cause harmful interference to radio communications. However, there is no guarantee that interference will not occur in a particular installation. If this equipment does cause harmful interference to radio or television reception, which can be determined by turning the equipment off and on, the user is encouraged to try to correct the interference by one or more of the following measures:

- Reorient or relocate the receiving antenna.
- Increase the separation between the equipment and receiver.
- Connect the equipment into an outlet on a circuit different from that to which the receiver is connected.
- Consult the dealer or an experienced radio/TV technician for help.

Note: The Grantee is not responsible for any changes or modifications not expressly approved by the party responsible for compliance. such modifications could void the user's authority to operate the equipment.

The device has been evaluated to meet general RF exposure requirement. To maintain compliance with FCC's RF exposure guidelines, the distance must be at least 20 cm between the radiator and your body, and fully supported by the operating and installation.