



FCC Part 15C Test Report

FCC ID: 2A4M6-007N

Applicant: Shenzhen Mulan Shijia Technology Co., Ltd.

Address: Dapeng Village Niushenling, Wangmu Community, Dapeng Street, Dapeng New District, Shenzhen, China

Manufacturer: Shenzhen Mulan Shijia Technology Co., Ltd.

Address: Dapeng Village Niushenling, Wangmu Community, Dapeng Street, Dapeng New District, Shenzhen, China

EUT: Surveillance Camera

Trade Mark: N/A

Model Number: 007N, 007, 007P, 007S

Date of Receipt: Jun. 05, 2024

Test Date: Jun. 05, 2024 – Jun. 17, 2024

Date of Report: Jun. 17, 2024

Prepared By: Shenzhen DL Testing Technology Co., Ltd.

Address: 101-201, Building C, Shuanghuan, No.8, Baoqing Road, Baolong Industrial Zone, Baolong Street, Longgang District, Shenzhen, Guangdong, China

Applicable Standards: FCC PART 15 C 15.247
ANSI C63.10:2013

Test Result: Pass

Report Number: DL-240605001ER

Prepared (Test Engineer): Alisa Song

Reviewer (Supervisor): Jack Bu

Approved (Manager): Jade Yang



This test report is based on a single evaluation of one sample of above mentioned products. It is not permitted to be duplicated in extracts without written approval of Shenzhen DL Testing Technology Co., Ltd.



Table of Contents	Page
1 . SUMMARY OF TEST RESULTS	4
1.1 MEASUREMENT UNCERTAINTY	4
2 . GENERAL INFORMATION	5
2.1 GENERAL DESCRIPTION OF EUT	5
2.2 DESCRIPTION OF TEST MODES	6
2.3 BLOCK DIGRAM SHOWING THE CONFIGURATION OF SYSTEM TESTED	6
2.4 DESCRIPTION OF SUPPORT UNITS(CONDUCTED MODE)	7
2.5 TABLE OF PARAMETERS OF TEST SOFTWARE SETTING	7
2.6 EQUIPMENTS LIST FOR ALL TEST ITEMS	8
3 . EMC EMISSION TEST	9
3.1 CONDUCTED EMISSION MEASUREMENT	9
3.1.1 POWER LINE CONDUCTED EMISSION LIMITS	9
3.1.2 TEST PROCEDURE	9
3.1.3 DEVIATION FROM TEST STANDARD	9
3.1.4 TEST SETUP	10
3.1.5 EUT OPERATING CONDITIONS	10
3.1.6 TEST RESULTS	10
3.2 RADIATED EMISSION MEASUREMENT	15
3.2.1 RADIATED EMISSION LIMITS	15
3.2.2 TEST PROCEDURE	16
3.2.3 DEVIATION FROM TEST STANDARD	16
3.2.4 TEST SETUP	16
3.2.5 EUT OPERATING CONDITIONS	17
3.2.6 TEST RESULTS (BETWEEN 9KHZ – 30 MHZ)	18
3.2.7 TEST RESULTS (BETWEEN 30MHZ – 1GHZ)	19
3.2.8 TEST RESULTS (1GHZ~25GHZ)	23
3.3 RADIATED BAND EMISSION MEASUREMENT	26
3.3.1 TEST REQUIREMENT:	26
3.3.2 TEST PROCEDURE	26
3.3.3 DEVIATION FROM TEST STANDARD	26
3.3.4 TEST SETUP	27
3.3.5 EUT OPERATING CONDITIONS	27
3.4 CONDUCTED BAND EDGE EMISSION&CONDUCTED SPURIOUS EMISSIONS MEASUREMENT	31
3.4.1 APPLICABLE STANDARD	31
3.4.2 TEST PROCEDURE	31
3.4.3 DEVIATION FROM STANDARD	31



Table of Contents	Page
3.4.4 TEST SETUP	31
3.4.5 EUT OPERATION CONDITIONS	31
3.4.6 TEST RESULTS	31
4 . AVERAGE OUTPUT POWER	34
4.1 APPLIED PROCEDURES / LIMIT	34
4.1.1 TEST PROCEDURE	34
4.1.2 DEVIATION FROM STANDARD	34
4.1.3 TEST SETUP	34
4.1.4 EUT OPERATION CONDITIONS	34
4.1.5 TEST RESULTS	35
5 . POWER SPECTRAL DENSITY TEST	38
5.1 APPLIED PROCEDURES / LIMIT	38
5.1.1 TEST PROCEDURE	38
5.1.2 DEVIATION FROM STANDARD	38
5.1.3 TEST SETUP	38
5.1.4 EUT OPERATION CONDITIONS	38
5.1.5 TEST RESULTS	39
6 . 6DB BANDWIDTH TEST	42
6.1 APPLIED PROCEDURES / LIMIT	42
6.1.1 TEST PROCEDURE	42
6.1.2 DEVIATION FROM STANDARD	42
6.1.3 TEST SETUP	42
6.1.4 EUT OPERATION CONDITIONS	42
6.1.5 TEST RESULTS	43
7 . ANTENNA REQUIREMENT	46
7.1 STANDARD REQUIREMENT	46
7.2 EUT ANTENNA	46
8 . TEST SEUUP PHOTO	46
9 . EUT PHOTO	46



1. SUMMARY OF TEST RESULTS

Test procedures according to the technical standards:

FCC Part15 (15.247) , Subpart C			
Standard Section	Test Item	Judgment	Remark
15.207	Conducted Emission	PASS	
15.205, 15.209, 15.247(d)	Radiated Spurious Emission	PASS	
15.205, 15.247(d)	Band Edge Emission& Conducted Spurious Emissions	PASS	
15.247(b)	Average Output Power	PASS	
15.247(a)(2)	6dB Bandwidth	PASS	
15.247(e)	Power Spectral Density	PASS	
15.203	Antenna Requirement	PASS	

NOTE:

(1) "N/A" denotes test is not applicable in this Test Report

Test lab: Shenzhen DL Testing Technology Co., Ltd.

Address: 101-201, Building C, Shuanghuan, No.8, Baoqing Road, Baolong Industrial Zone, Baolong Street, Longgang District, Shenzhen, Guangdong, China

FCC Test Firm Registration Number: 854456

Designation Number: CN1307

IC Registered No.: 27485

CAB ID.: CN0118

1.1 MEASUREMENT UNCERTAINTY

The reported uncertainty of measurement $y \pm U$, where expanded uncertainty U is based on a standard uncertainty multiplied by a coverage factor of $k=2$ providing a level of confidence of approximately 95 %

No.	Item	Uncertainty
1	Conducted Emission Test	$\pm 2.56\text{dB}$
2	RF power,conducted	$\pm 0.42\text{dB}$
3	Spurious emissions,conducted	$\pm 2.76\text{dB}$
4	All emissions,radiated(<1G)	$\pm 3.65\text{dB}$
5	All emissions,radiated(>1G)	$\pm 4.89\text{dB}$
6	Temperature	$\pm 0.5^\circ\text{C}$
7	Humidity	$\pm 2\%$
8	6dB Bandwidth	$\pm 0.2\text{MHz}$



2. GENERAL INFORMATION

2.1 GENERAL DESCRIPTION OF EUT

Product Name:	Surveillance Camera
Trademark	N/A
Model No.:	007N, 007, 007P, 007S
Test Model:	007N
Model Difference:	The product's different for model number.
Operation Frequency:	2412~2462 MHz for 802.11b/g/nHT20
Channel numbers:	11 Channels for 802.11b/g/n(HT20)
Channel separation:	5MHz
Modulation technology:	802.11b: DSSS (CCK, DQPSK, DBPSK) 802.11g/n(20): OFDM(QPSK, BPSK, 16-QAM, 64-QAM)
Rate of Transmitter	802.11b: 11/5.5/2/1Mbps 802.11g: 54/48/36/24/18/12/9/6Mbps 802.11n: up to 150Mbps
Antenna Type:	FPC Antenna
Antenna gain:	2.37 dBi
Power supply:	Input:110-240V ~ 60Hz DC 5V from charger Battery: DC 3.7V

Note:

- 1.For a more detailed features description, please refer to the manufacturer's specifications or the User's Manual.
- 2.The EUT's all information provided by client.

2. Channel List(802.11b/g/nHT20)

Channel	Frequency (GHz)	Channel	Frequency (GHz)
01	2.412	07	2.442
02	2.417	08	2.447
03	2.422	09	2.452
04	2.427	10	2.457
05	2.432	11	2.462
06	2.437		



2.2 DESCRIPTION OF TEST MODES

To investigate the maximum EMI emission characteristics generated from EUT, the test system was pre-scanning tested based on the consideration of following EUT operation mode or test configuration mode which possibly have effect on EMI emission level. Each of these EUT operation mode(s) or test configuration mode(s) mentioned above was evaluated respectively.

Pretest Mode	Description
Mode 1	802.11b CH1/ CH6/ CH11
Mode 2	802.11g CH1/ CH6/ CH11
Mode 3	802.11nHT20 CH1/ CH6/ CH11
Mode 4	Link Mode
For Conducted Emission	
Final Test Mode	Description
Mode 4	Link Mode (DC Input)
Mode 5	Link Mode(AC Input)
For Radiated Emission	
Final Test Mode	Description
Mode 1	802.11b CH1/ CH6/ CH11
Mode 2	802.11g CH1/ CH6/ CH11
Mode 3	802.11nHT20 CH1/ CH6/ CH11
Mode 4	Link Mode (3.7V Battery)
Mode 5	Link Mode(AC Input)

Note: 1. The measurements are performed at the highest, middle, lowest available channels.
 2. During the test, the duty cycle >98%, the test voltage was tuned from 85% to 115% of the nominal rated supply voltage, and found that the worst case was under the nominal rated supply condition. So the report just shows that condition's data.

2.3 BLOCK DIAGRAM SHOWING THE CONFIGURATION OF SYSTEM TESTED

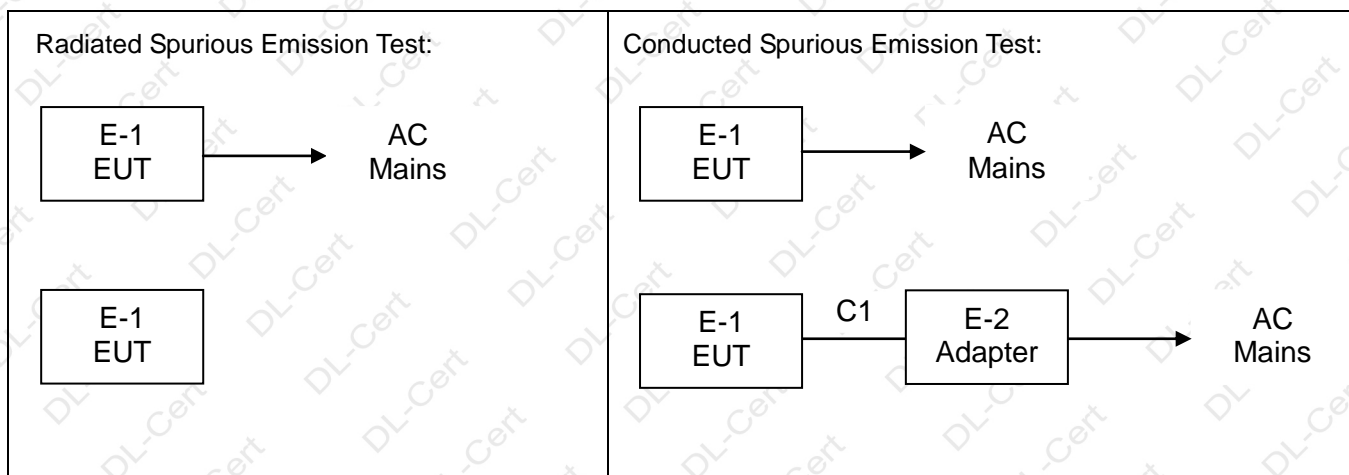



2.4 DESCRIPTION OF SUPPORT UNITS(CONDUCTED MODE)

The EUT has been tested as an independent unit together with other necessary accessories or support units. The following support units or accessories were used to form a representative test configuration during the tests.

Item	Equipment	Model/Type No.	Series No.	Note
E-1	Surveillance Camera	007N	N/A	EUT
E-2	Adapter	HW-0501000E		(Provide by test lab): Manufacturer: HAIWEI I/P: AC 100-240V 50/60Hz O/P: DC 5V 1A

Item	Shielded Type	Ferrite Core	Length	Note
C1	No	No	0.5m	Mini USB Line

Note:

- (1) For detachable type I/O cable should be specified the length in cm in 『Length』 column.

2.5 TABLE OF PARAMETERS OF TEST SOFTWARE SETTING

During testing, channel & power controlling software provided by the customer was used to control the operating channel as well as the output power level. The RF output power selection is for the setting of RF output power expected by the customer and is going to be fixed on the end product.

Max output power Setting			
Test software Version	Test program: Test V1.2.1		
Mode	802.11b	802.11g	802.11n HT20
Data Rate	1Mbps	6Mbps	MSC0
Power Setting of Software	60	60	60



2.6 EQUIPMENTS LIST FOR ALL TEST ITEMS

Radiation test, Band-edge test and 6db bandwidth test equipment

Item	Equipment	Manufacturer	Type No.	Serial No.	Last calibration	Calibrated until
1	Spectrum Analyzer (9kHz-26.5GHz)	Agilent	E4408B	MY50140780	Nov. 04, 2023	Nov. 03, 2024
2	Test Receiver (9kHz-7GHz)	R&S	ESRP7	101393	Nov. 04, 2023	Nov. 03, 2024
3	Bilog Antenna (30MHz-1GHz)	R&S	VULB9162	00306	Nov. 04, 2023	Nov. 03, 2024
4	Horn Antenna (1GHz-18GHz)	Schwarzbeck	BBHA9120D	02139	Nov. 04, 2023	Nov. 03, 2024
5	Horn Antenna (18GHz-40GHz)	A.H. Systems	SAS-574	588	Nov. 04, 2023	Nov. 03, 2024
6	Amplifier (9KHz-6GHz)	Schwarzbeck	BBV9743B	00153	Nov. 04, 2023	Nov. 03, 2024
7	Amplifier (1GHz-18GHz)	EMEC	EM01G8GA	00270	Nov. 04, 2023	Nov. 03, 2024
8	Amplifier (18GHz-40GHz)	Quanjuda	DLE-161	97	Nov. 04, 2023	Nov. 03, 2024
9	Loop Antenna (9KHz-30MHz)	Schwarzbeck	FMZB1519B	00014	Nov. 04, 2023	Nov. 03, 2024
10	RF cables1 (9kHz-1GHz)	ChengYu	966	004	Nov. 04, 2023	Nov. 03, 2024
11	RF cables2 (1GHz-40GHz)	ChengYu	966	003	Nov. 04, 2023	Nov. 03, 2024
12	Antenna connector	Florida RF Labs	N/A	RF 01#	Nov. 04, 2023	Nov. 03, 2024
13	Power probe	KEYSIGHT	U2021XA	MY55210018	Nov. 04, 2023	Nov. 03, 2024
14	Signal Analyzer 9kHz-26.5GHz	Agilent	N9020A	MY55370280	Nov. 04, 2023	Nov. 03, 2024
15	Test Receiver 20kHz-40GHz	R&S	ESU 40	100376	Nov. 04, 2023	Nov. 03, 2024
16	D.C. Power Supply	LongWei	PS-305D	010964729	Nov. 04, 2023	Nov. 03, 2024

Conduction Test equipment

Item	Equipment	Manufacturer	Type No.	Serial No.	Last calibration	Calibrated until
1	843 Shielded Room	ChengYu	843 Room	843	Sep. 20, 2022	Sep. 19, 2025
2	EMI Receiver	R&S	ESR	101421	Nov. 04, 2023	Nov. 03, 2024
3	LISN	R&S	ENV216	102417	Nov. 04, 2023	Nov. 03, 2024
4	843 Cable 1#	ChengYu	CE Cable	001	Nov. 04, 2023	Nov. 03, 2024

Other

Item	Name	Manufacturer	Model	Software version
1	EMC Conduction Test System	FALA	EZ_EMCC	EMC-CON 3A1.1
2	EMC radiation test system	FALA	EZ_EMCC	FA-03A2
3	RF test system	MAIWEI	MTS8310	2.0.0.0
4	RF communication test system	MAIWEI	MTS8200	2.0.0.0



3. EMC EMISSION TEST

3.1 CONDUCTED EMISSION MEASUREMENT

3.1.1 POWER LINE CONDUCTED EMISSION Limits (Frequency Range 150KHz-30MHz)

FREQUENCY (MHz)	Limit (dBuV)		Standard
	Quasi-peak	Average	
0.15 -0.50	66 - 56 *	56 - 46 *	FCC
0.50 -5.0	56.00	46.00	FCC
5.0 -30.0	60.00	50.00	FCC

Note:

- (1) The tighter limit applies at the band edges.
- (2) The limit of " * " marked band means the limitation decreases linearly with the logarithm of the frequency in the range.

The following table is the setting of the receiver

Receiver Parameters	Setting
Attenuation	10 dB
Start Frequency	0.15 MHz
Stop Frequency	30 MHz
IF Bandwidth	9 kHz

3.1.2 TEST PROCEDURE

- a. The EUT was placed 0.8 meters from the horizontal ground plane with EUT being connected to the power mains through a line impedance stabilization network (LISN). All other support equipments powered from additional LISN(s). The LISN provide 50 Ohm/ 50uH of coupling impedance for the measuring instrument.
- b. Interconnecting cables that hang closer than 40 cm to the ground plane shall be folded back and forth in the center forming a bundle 30 to 40 cm long.
- c. I/O cables that are not connected to a peripheral shall be bundled in the center. The end of the cable may be terminated, if required, using the correct terminating impedance. The overall length shall not exceed 1 m.
- d. LISN at least 80 cm from nearest part of EUT chassis.
- e. For the actual test configuration, please refer to the related Item –EUT Test Photos.

3.1.3 DEVIATION FROM TEST STANDARD

No deviation

3.1.4 TEST SETUP

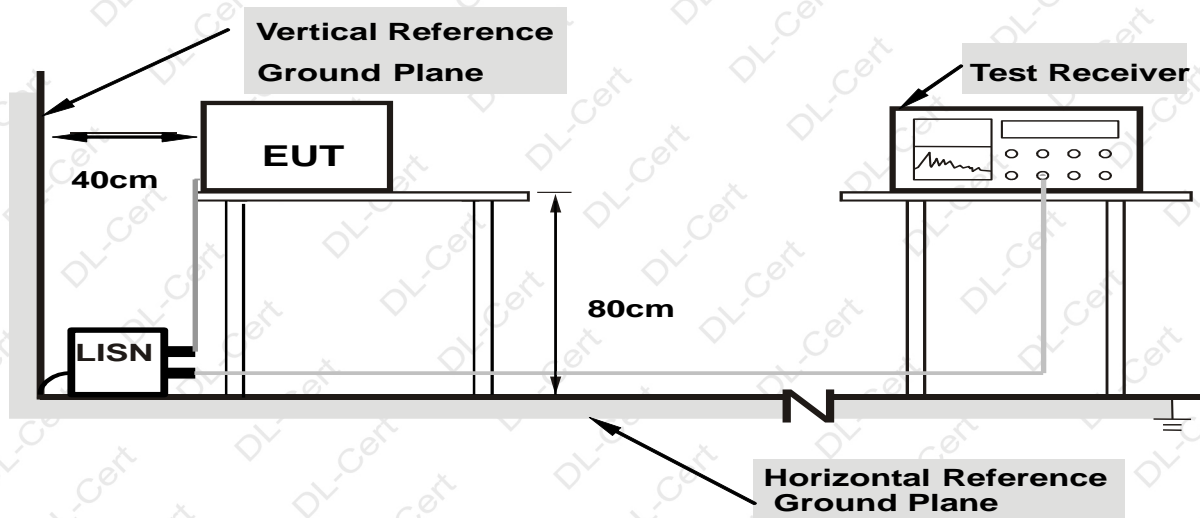

Note: 1. Support units were connected to second LISN.

2. Both of LISNs (AMN) are 80 cm from EUT and at least 80 from other units and other metal planes

3.1.5 EUT OPERATING CONDITIONS

The EUT was configured for testing in a typical fashion (as a customer would normally use it). The EUT has been programmed to continuously transmit during test. This operating condition was tested and used to collect the included data.

We pretest AC 120V and AC 230V, the worst voltage was AC 120V and the data recording in the report.

3.1.6 TEST RESULTS



Temperature:	25 °C	Relative Humidity:	54%
Pressure:	1010hPa	Phase :	L
Test Voltage :	AC 120V/60Hz	Test Mode:	Mode 4

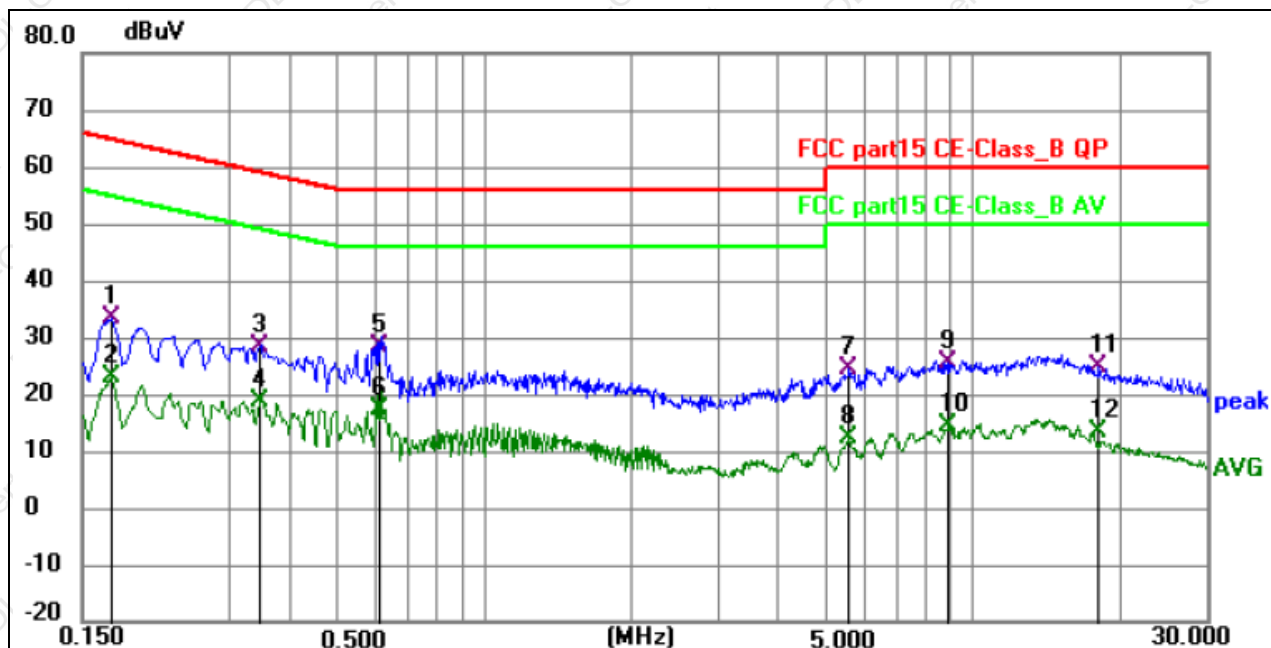

Remark:

Margin = Limit – Level, Correct Factor = Cable lose + LISN insertion loss, Level= Reading + Correct factor

No.	Frequency (MHz)	Reading (dBuV)	Factor (dB)	Level (dBuV)	Limit (dBuV)	Margin (dB)	Detector	P/F	Remark
1	0.1724	23.19	10.09	33.28	64.84	-31.56	QP	P	
2	0.1724	12.86	10.09	22.95	54.84	-31.89	AVG	P	
3	0.3480	19.27	9.10	28.37	59.01	-30.64	QP	P	
4	0.3480	9.53	9.10	18.63	49.01	-30.38	AVG	P	
5 *	0.6134	19.10	9.39	28.49	56.00	-27.51	QP	P	
6	0.6134	7.99	9.39	17.38	46.00	-28.62	AVG	P	
7	5.5904	14.36	9.97	24.33	60.00	-35.67	QP	P	
8	5.5904	2.29	9.97	12.26	50.00	-37.74	AVG	P	
9	8.9115	15.45	10.07	25.52	60.00	-34.48	QP	P	
10	8.9115	4.47	10.07	14.54	50.00	-35.46	AVG	P	
11	18.0780	14.42	10.33	24.75	60.00	-35.25	QP	P	
12	18.0780	2.99	10.33	13.32	50.00	-36.68	AVG	P	



Temperature:	25 °C	Relative Humidity:	54%
Pressure:	1010hPa	Phase :	N
Test Voltage :	AC 120V/60Hz	Test Mode:	Mode 4

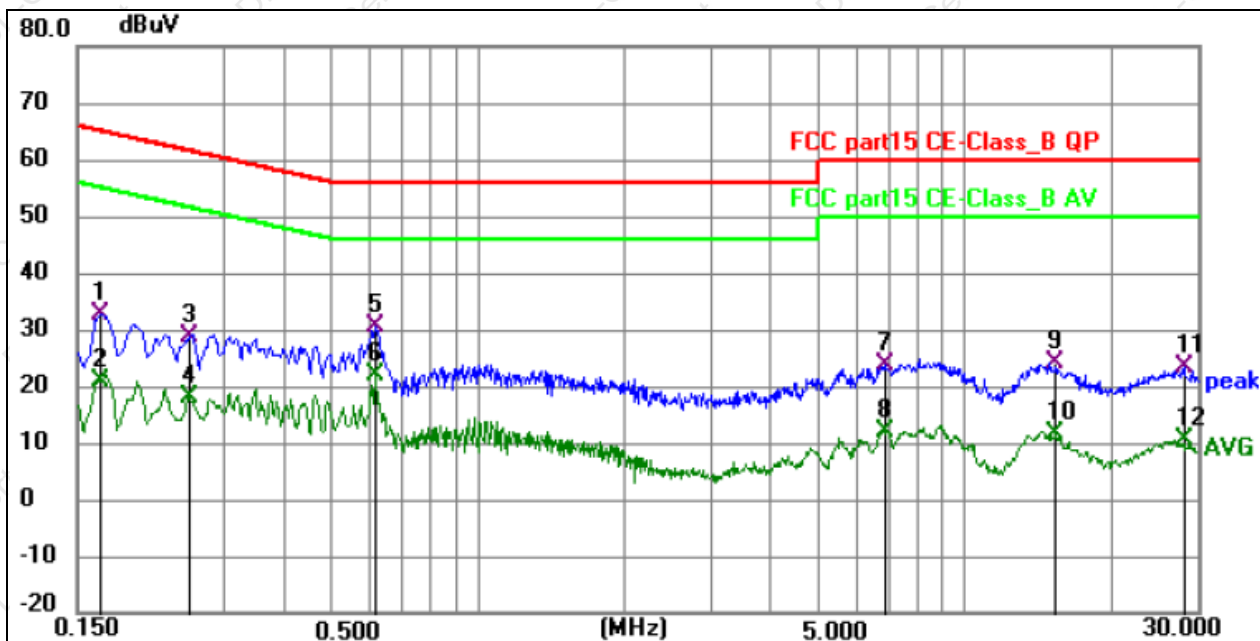

Remark:

Margin = Limit – Level, Correct Factor = Cable lose + LISN insertion loss, Level= Reading + Correct factor

No.	Frequency (MHz)	Reading (dBuV)	Factor (dB)	Level (dBuV)	Limit (dBuV)	Margin (dB)	Detector	P/F	Remark
1	0.1680	22.84	9.86	32.70	65.06	-32.36	QP	P	
2	0.1680	11.09	9.86	20.95	55.06	-34.11	AVG	P	
3	0.2575	19.80	9.01	28.81	61.51	-32.70	QP	P	
4	0.2575	9.07	9.01	18.08	51.51	-33.43	AVG	P	
5	0.6180	21.38	9.30	30.68	56.00	-25.32	QP	P	
6 *	0.6180	12.63	9.30	21.93	46.00	-24.07	AVG	P	
7	6.8550	13.59	10.13	23.72	60.00	-36.28	QP	P	
8	6.8550	1.93	10.13	12.06	50.00	-37.94	AVG	P	
9	15.3420	13.69	10.39	24.08	60.00	-35.92	QP	P	
10	15.3420	1.25	10.39	11.64	50.00	-38.36	AVG	P	
11	28.1625	12.15	11.13	23.28	60.00	-36.72	QP	P	
12	28.1625	-0.71	11.13	10.42	50.00	-39.58	AVG	P	



Temperature:	25 °C	Relative Humidity:	54%
Pressure:	1010hPa	Phase :	L
Test Voltage :	AC 120V/60Hz	Test Mode:	Mode 5

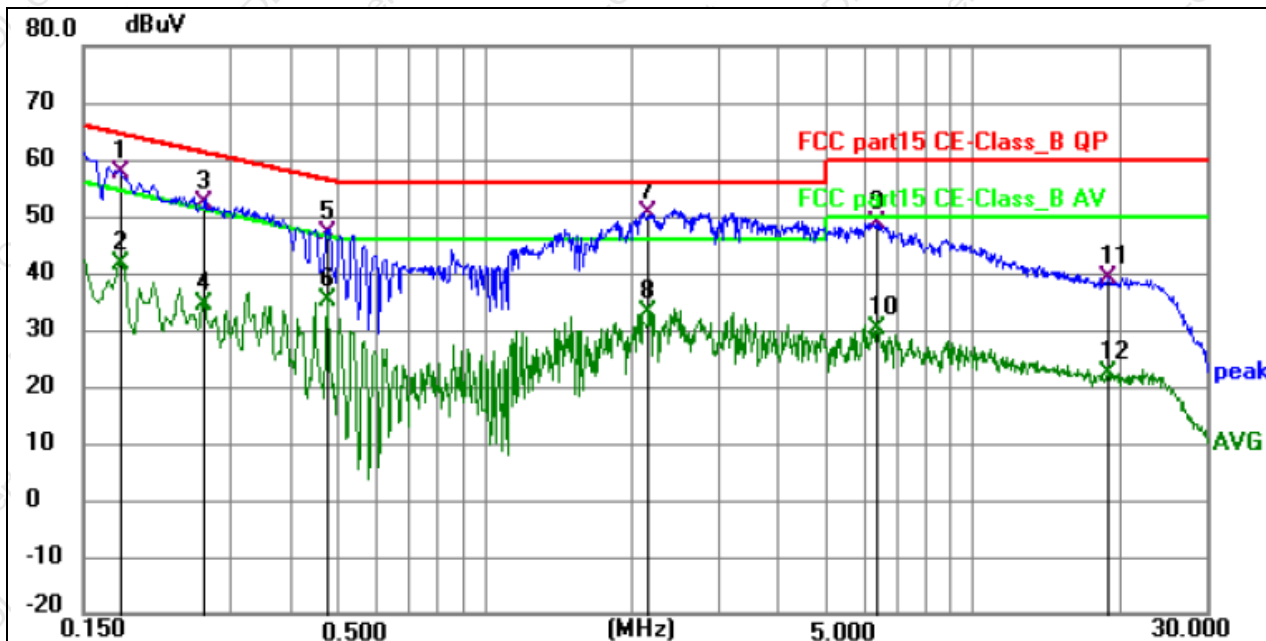

Remark:

Margin = Limit – Level, Correct Factor = Cable lose + LISN insertion loss, Level= Reading + Correct factor

No.	Frequency (MHz)	Reading (dBuV)	Factor (dB)	Level (dBuV)	Limit (dBuV)	Margin (dB)	Detector	P/F	Remark
1	0.1796	47.65	9.94	57.59	64.50	-6.91	QP	P	
2	0.1796	31.79	9.94	41.73	54.50	-12.77	AVG	P	
3	0.2670	43.15	9.25	52.40	61.21	-8.81	QP	P	
4	0.2670	25.34	9.25	34.59	51.21	-16.62	AVG	P	
5	0.4761	37.79	9.24	47.03	56.41	-9.38	QP	P	
6	0.4761	25.93	9.24	35.17	46.41	-11.24	AVG	P	
7 *	2.1615	40.57	9.93	50.50	56.00	-5.50	QP	P	
8	2.1615	23.15	9.93	33.08	46.00	-12.92	AVG	P	
9	6.3285	38.75	9.99	48.74	60.00	-11.26	QP	P	
10	6.3285	20.07	9.99	30.06	50.00	-19.94	AVG	P	
11	19.0050	28.79	10.36	39.15	60.00	-20.85	QP	P	
12	19.0050	12.06	10.36	22.42	50.00	-27.58	AVG	P	



Temperature:	25 °C	Relative Humidity:	54%
Pressure:	1010hPa	Phase :	N
Test Voltage :	AC 120V/60Hz	Test Mode:	Mode 5

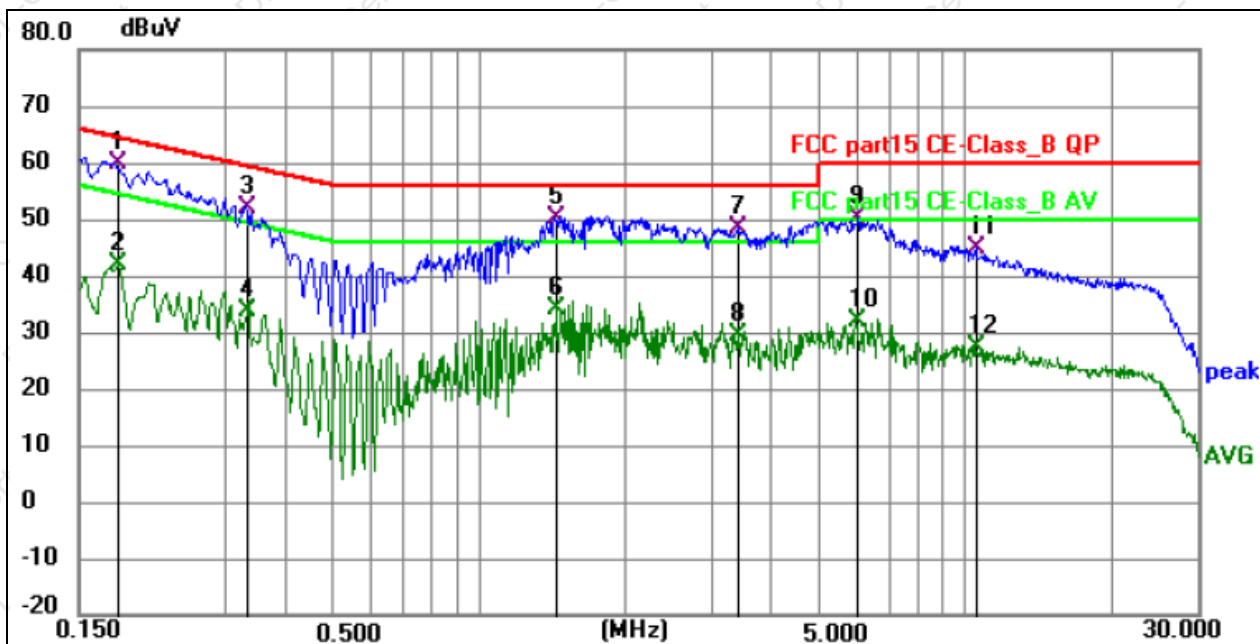

Remark:

Margin = Limit – Level, Correct Factor = Cable lose + LISN insertion loss, Level= Reading + Correct factor

No.	Frequency (MHz)	Reading (dBuV)	Factor (dB)	Level (dBuV)	Limit (dBuV)	Margin (dB)	Detector	P/F	Remark
1 *	0.1814	50.31	9.46	59.77	64.42	-4.65	QP	P	
2	0.1814	32.41	9.46	41.87	54.42	-12.55	AVG	P	
3	0.3338	42.91	9.15	52.06	59.36	-7.30	QP	P	
4	0.3338	24.64	9.15	33.79	49.36	-15.57	AVG	P	
5	1.4370	40.40	9.66	50.06	56.00	-5.94	QP	P	
6	1.4370	24.27	9.66	33.93	46.00	-12.07	AVG	P	
7	3.4350	38.30	10.00	48.30	56.00	-7.70	QP	P	
8	3.4350	19.61	10.00	29.61	46.00	-16.39	AVG	P	
9	6.0090	39.95	10.10	50.05	60.00	-9.95	QP	P	
10	6.0090	21.80	10.10	31.90	50.00	-18.10	AVG	P	
11	10.5540	34.51	10.31	44.82	60.00	-15.18	QP	P	
12	10.5540	16.94	10.31	27.25	50.00	-22.75	AVG	P	



3.2 RADIATED EMISSION MEASUREMENT

3.2.1 RADIATED EMISSION LIMITS (Frequency Range 9kHz-1000MHz)

In case the emission fall within the restricted band specified on 15.205(a), then the 15.209(a) limit in the table below has to be followed.

Frequencies (MHz)	Field Strength (micovolts/meter)	Measurement Distance (meters)
0.009~0.490	2400/F(KHz)	300
0.490~1.705	24000/F(KHz)	30
1.705~30.0	30	30
30~88	100	3
88~216	150	3
216~960	200	3
Above 960	500	3

LIMITS OF RADIATED EMISSION MEASUREMENT (Above 1000MHz)

FREQUENCY (MHz)	Limit (dBuV/m) (at 3M)	
	PEAK	AVERAGE
Above 1000	74	54

Notes:

- (1) The limit for radiated test was performed according to FCC PART 15C.
- (2) The tighter limit applies at the band edges.
- (3) Emission level (dBuV/m)=20log Emission level (uV/m).

Spectrum Parameter	Setting
Attenuation	Auto
Start Frequency	1000 MHz
Stop Frequency	25GHz
RB / VB (emission in restricted band)	1 MHz / 1 MHz for Peak, 1 MHz / 10Hz for Average

Receiver Parameter	Setting
Attenuation	Auto
Start ~ Stop Frequency	9kHz~150kHz / RB 200Hz for QP
Start ~ Stop Frequency	150kHz~30MHz / RB 9kHz for QP
Start ~ Stop Frequency	30MHz~1000MHz / RB 120kHz for QP

3.2.2 TEST PROCEDURE

Below 1GHz test procedure as below:

- The EUT was placed on the top of a rotating table 0.8 meters above the ground at a 3 meter semi-anechoic chamber. The table was rotated 360 degrees to determine the position of the highest radiation.
- The EUT was set 3 meters away from the interference-receiving antenna, which was mounted on the top of a variable-height antenna tower.
- The antenna height is varied from one meter to four meters above the ground to determine the maximum value of the field strength. Both horizontal and vertical polarizations of the antenna are set to make the measurement.
- For each suspected emission, the EUT was arranged to its worst case and then the antenna was tuned to heights from 1 meter to 4 meters (for the test frequency of below 30MHz, the antenna was tuned to heights 1 meter) and the rotatable table was turned from 0 degrees to 360 degrees to find the maximum reading.
- The test-receiver system was set to Peak Detect Function and Specified Bandwidth with Maximum Hold Mode.
- If the emission level of the EUT in peak mode was 10dB lower than the limit specified, then testing could be stopped and the peak values of the EUT would be reported. Otherwise the emissions that did not have 10dB margin would be re-tested one by one using peak, quasi-peak or average method as specified and then reported in a data sheet.

Above 1GHz test procedure as below:

- Different between above is the test site, change from Semi- Anechoic Chamber to fully Anechoic Chamber and change form table 0.8 metre to 0.8 metre(Above 18GHz the distance is 1 meter and table is 1.5 metre).
- Test the EUT in the lowest channel, the middle channel, the Highest channel

Note:

Both horizontal and vertical antenna polarities were tested and performed pretest to three orthogonal axis. The worst case emissions were reported

3.2.3 DEVIATION FROM TEST STANDARD

No deviation

3.2.4 TEST SETUP

(A) Radiated Emission Test-Up Frequency Below 30MHz

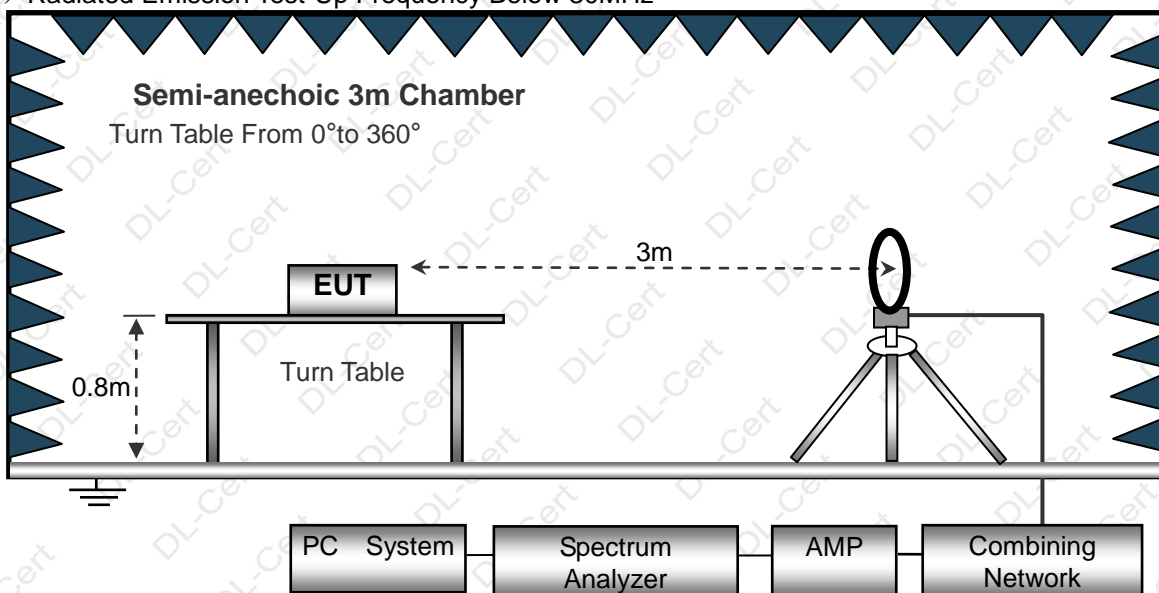

(B) Radiated Emission Test-Up Frequency 30MHz~1GHz

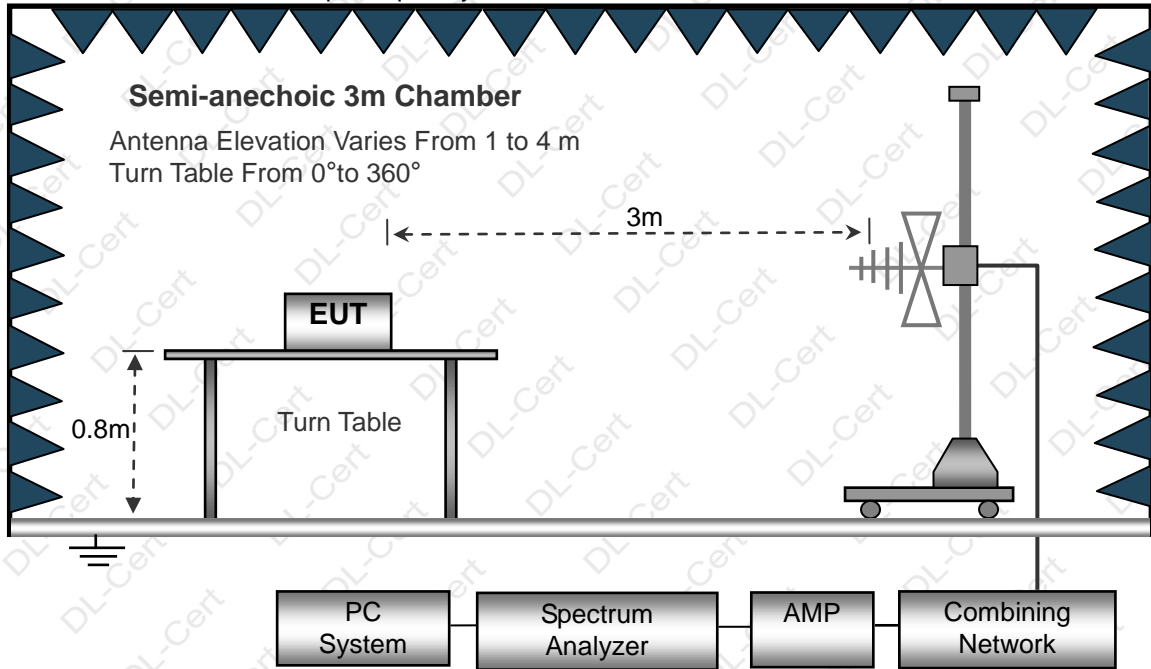

(C) Radiated Emission Test-Up Frequency Above 1GHz

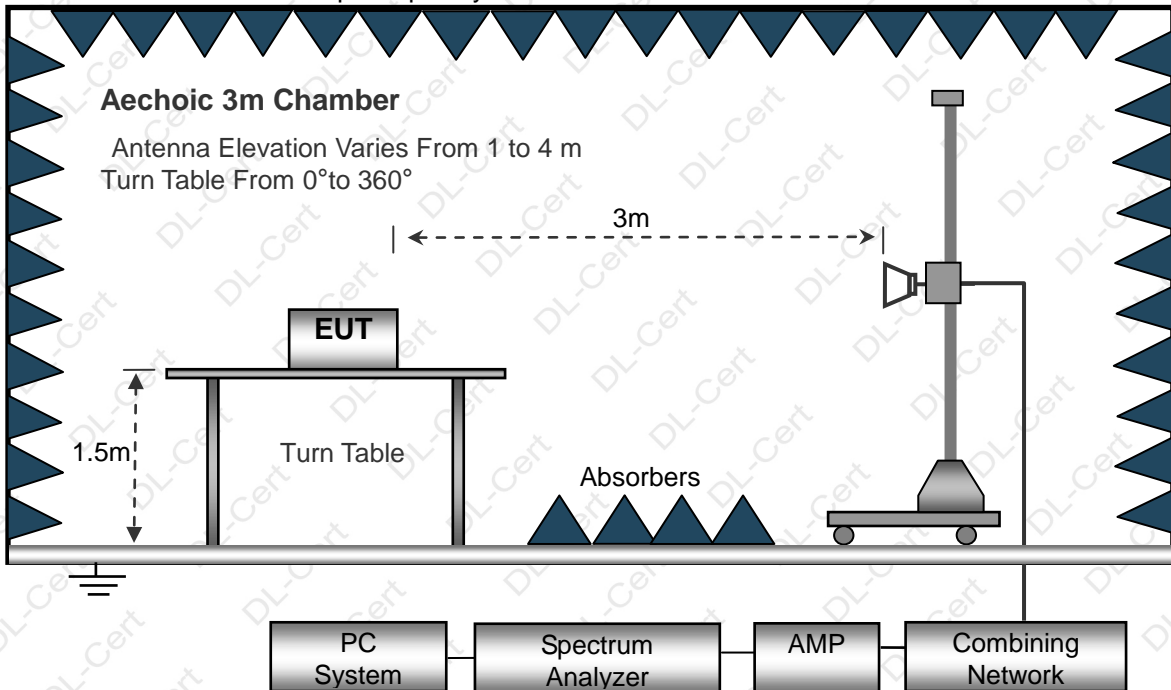

3.2.5 EUT OPERATING CONDITIONS

The EUT tested system was configured as the statements of 2.3 Unless otherwise a special operating condition is specified in the follows during the testing.

**3.2.6 TEST RESULTS (BETWEEN 9KHZ – 30 MHZ)**

Temperature:	20°C	Relative Humidity:	48%
Pressure:	1010 hPa	Test Voltage :	AC 120V/60Hz
Test Mode :	Mode 4	Polarization :	--

Freq. (MHz)	Reading (dBuV/m)	Limit (dBuV/m)	Margin (dB)	State P/F
--	--	--	--	PASS
--	--	--	--	PASS

NOTE:

The amplitude of spurious emissions which are attenuated by more than 20dB below the permissible value has no need to be reported.

Distance extrapolation factor = $40 \log(\text{specific distance}/\text{test distance})$ (dB);

Limit line = specific limits(dBuv) + distance extrapolation factor.



3.2.7 TEST RESULTS (BETWEEN 30MHZ – 1GHZ)

Temperature:	26°C	Relative Humidity:	54%
Pressure:	1010 hPa	Polarization :	Horizontal
Test Voltage :	DC 3.7V		
Test Mode :	Mode 4		

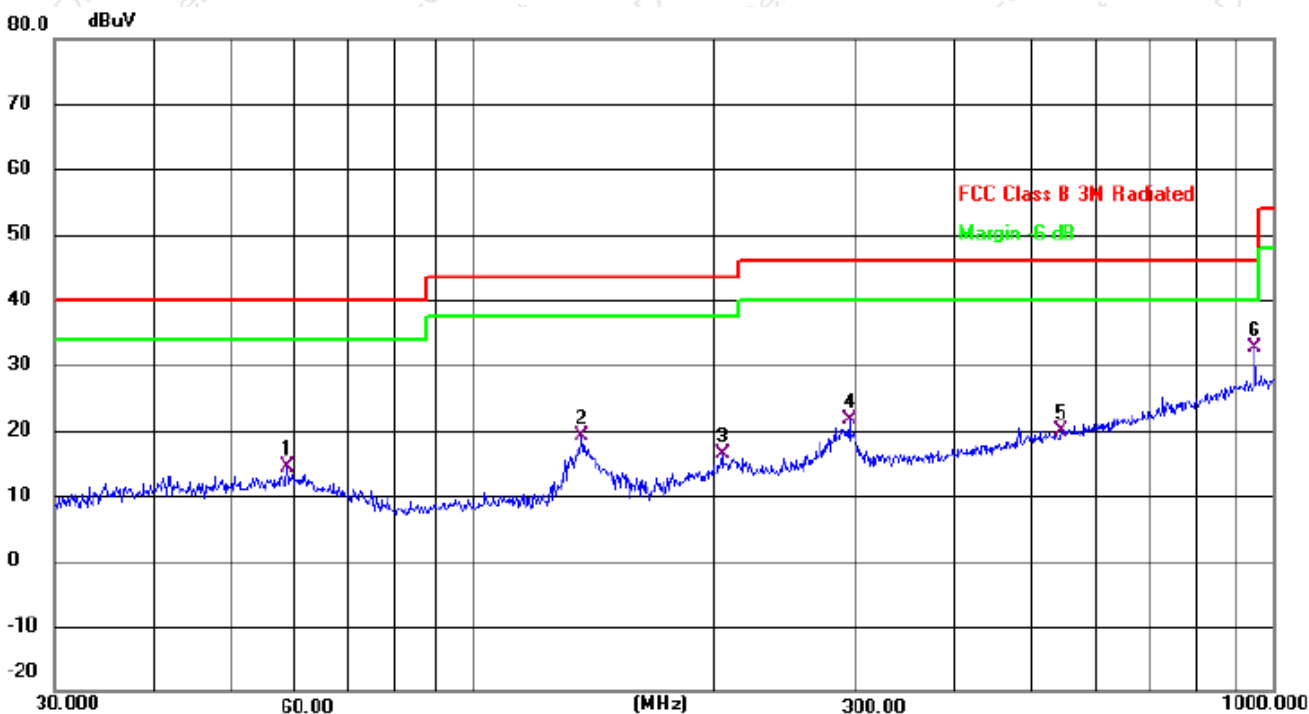

No.	Mk.	Freq. MHz	Reading Level dBuV	Correct Factor dB	Measure- ment dBuV	Limit dB	Margin dB	Detector
1		58.6126	27.26	-12.77	14.49	40.00	-25.51	QP
2		136.9391	36.44	-17.25	19.19	43.50	-24.31	QP
3		204.9551	30.91	-14.54	16.37	43.50	-27.13	QP
4		295.1469	33.13	-11.55	21.58	46.00	-24.42	QP
5		543.2742	26.71	-6.92	19.79	46.00	-26.21	QP
6	*	948.7610	32.47	0.20	32.67	46.00	-13.33	QP

Remark:

Correct Factor = Cable loss + Antenna factor – Preamplifier;

Level = Reading Level + Correct Factor; Margin = Level - Limit;



Temperature:	26°C	Relative Humidity:	54%
Pressure:	1010 hPa	Polarization :	Vertical
Test Voltage :	DC 3.7V		
Test Mode :	Mode 4		



No.	Mk.	Freq. MHz	Reading Level dBuV	Correct Factor dB	Measure- ment dBuV	Limit dB	Margin dB	Detector
1		59.6493	31.15	-12.72	18.43	40.00	-21.57	QP
2		77.3210	41.13	-16.96	24.17	40.00	-15.83	QP
3		137.9028	34.41	-17.30	17.11	43.50	-26.39	QP
4		202.1004	30.01	-14.65	15.36	43.50	-28.14	QP
5		475.4991	28.18	-8.09	20.09	46.00	-25.91	QP
6	*	948.7609	33.52	0.20	33.72	46.00	-12.28	QP

Remark:

Correct Factor = Cable loss + Antenna factor – Preamplifier;

Level = Reading Level + Correct Factor; Margin = Level - Limit;



Temperature:	26°C	Relative Humidity:	54%
Pressure:	1010 hPa	Polarization :	Horizontal
Test Voltage :	AC 120V/60Hz		
Test Mode :	Mode 5		

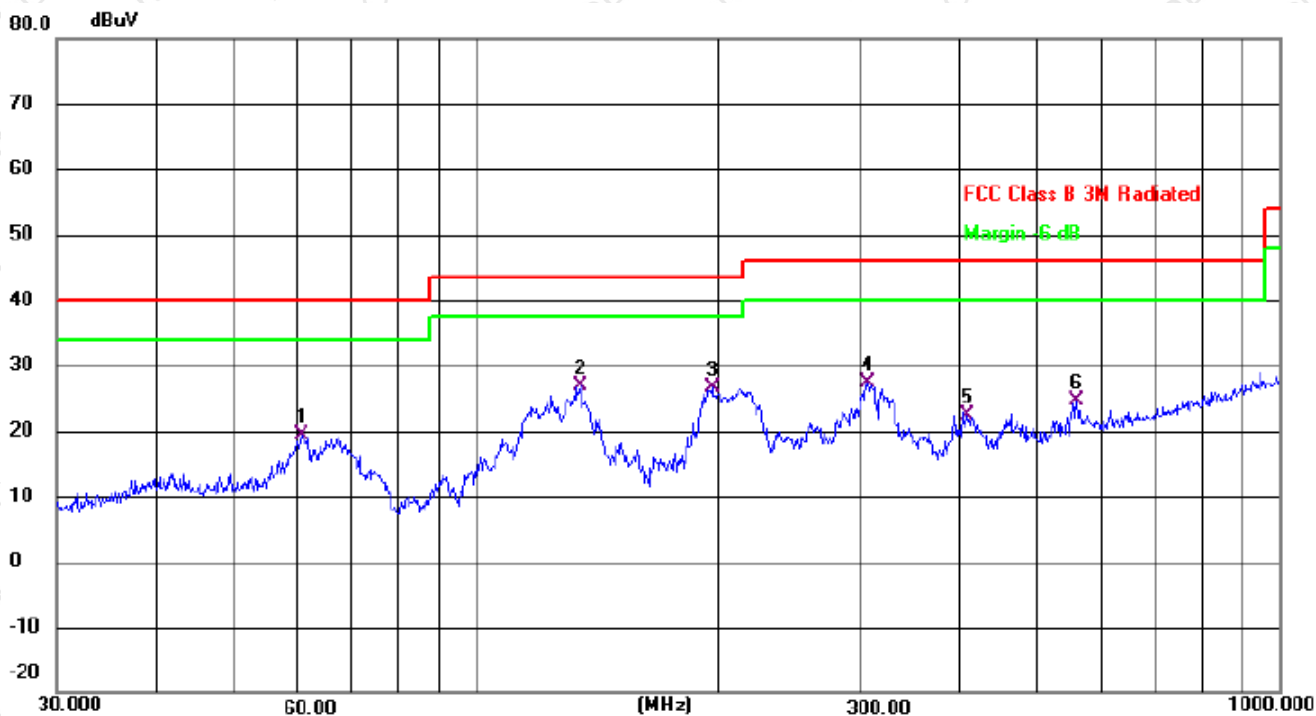

No.	Mk.	Freq. MHz	Reading Level dBuV	Correct Factor dB	Measure- ment dBuV	Limit dB	Margin dB	Detector
1		60.4919	32.25	-12.83	19.42	40.00	-20.58	QP
2	*	134.5592	43.92	-17.16	26.76	43.50	-16.74	QP
3		196.5098	41.46	-14.94	26.52	43.50	-16.98	QP
4		306.7537	38.59	-11.31	27.28	46.00	-18.72	QP
5		407.5145	32.07	-9.61	22.46	46.00	-23.54	QP
6		558.7302	31.29	-6.70	24.59	46.00	-21.41	QP

Remark:

Correct Factor = Cable loss + Antenna factor – Preamplifier;

Level = Reading Level + Correct Factor; Margin = Level - Limit;



Temperature:	26°C	Relative Humidity:	54%
Pressure:	1010 hPa	Polarization :	Vertical
Test Voltage :	AC 120V/60Hz		
Test Mode :	Mode 5		

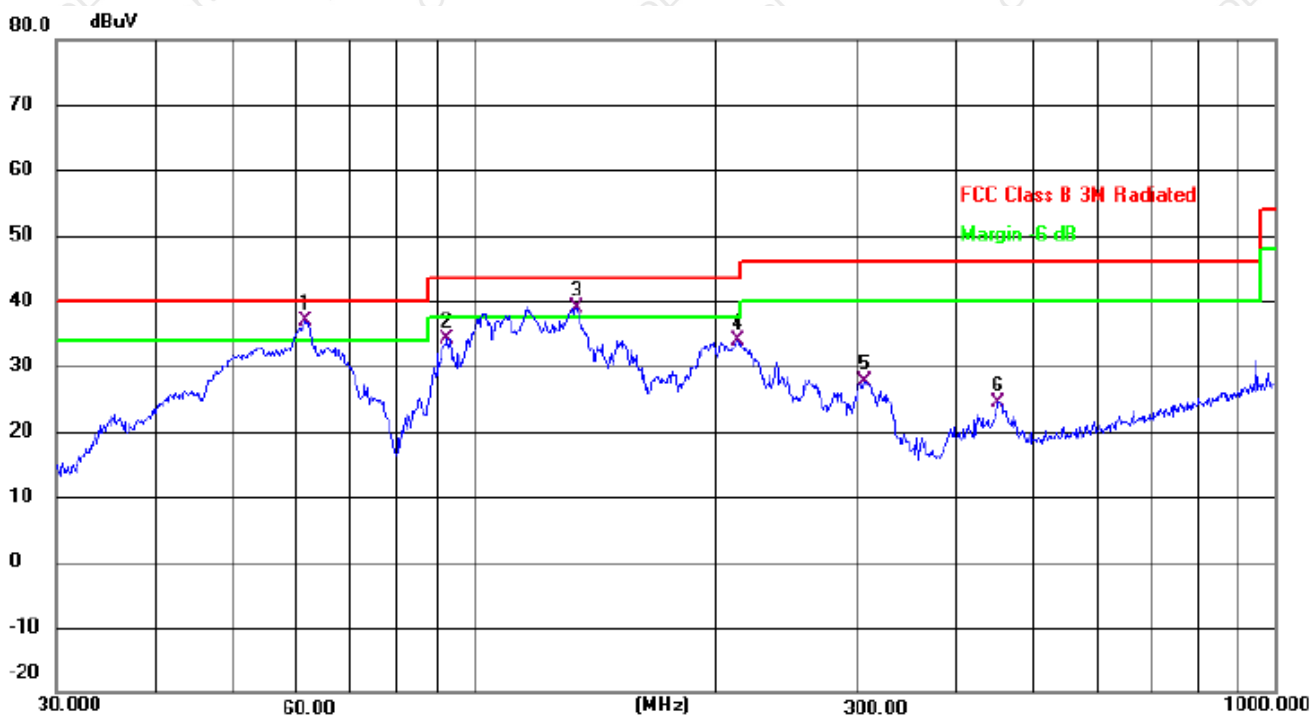

No.	Mk.	Freq. MHz	Reading Level dBuV	Correct Factor dB	Measure- ment dBuV	Limit dB	Margin dB	Detector
1	*	61.5618	49.93	-13.11	36.82	40.00	-3.18	QP
2		92.4624	50.98	-16.89	34.09	43.50	-9.41	QP
3	!	134.0881	56.05	-17.13	38.92	43.50	-4.58	QP
4		213.0151	48.01	-14.22	33.79	43.50	-9.71	QP
5		306.7537	39.01	-11.31	27.70	46.00	-18.30	QP
6		449.5558	32.93	-8.67	24.26	46.00	-21.74	QP

Remark:

Correct Factor = Cable loss + Antenna factor – Preamplifier;

Level = Reading Level + Correct Factor; Margin = Level - Limit;



3.2.8 TEST RESULTS (1GHZ~25GHZ)

802.11b

Polar (H/V)	Frequency	Meter Reading	Pre-amplifier	Cable Loss	Antenna Factor	Emission Level	Limits	Margin	Detector Type
	(MHz)	(dBuV)	(dB)	(dB)	(dB/m)	(dBuV/m)	(dBuV/m)	(dB)	
operation frequency:2412									
V	4824	67.38	50.65	6.88	31.29	54.90	74.00	-19.10	PK
V	4824	54.81	50.65	6.88	31.29	42.33	54.00	-11.67	AV
V	7236	65.51	49.98	7.16	36.63	59.32	74.00	-14.68	PK
V	7236	48.19	49.98	7.16	36.63	42.00	54.00	-12.00	AV
V	16087	49.41	51.53	11.34	41.52	50.74	74.00	-23.26	PK
H	4824	68.02	50.65	6.88	31.29	55.54	74.00	-18.46	PK
H	4824	55.19	50.65	6.88	31.29	42.71	54.00	-11.29	AV
H	7236	66.73	49.98	7.16	36.63	60.54	74.00	-13.46	PK
H	7236	46.88	49.98	7.16	36.63	40.69	54.00	-13.31	AV
H	16087	48.18	51.53	11.34	41.52	49.51	74.00	-24.49	PK
operation frequency:2437									
V	4874	66.03	50.67	6.89	31.38	53.63	74.00	-20.37	PK
V	4874	54.37	50.67	6.89	31.38	41.97	54.00	-12.03	AV
V	7311	67.94	50.02	7.24	36.63	61.79	74.00	-12.21	PK
V	7311	45.31	50.02	7.24	36.63	39.16	54.00	-14.84	AV
V	16087	47.36	51.53	11.34	41.52	48.69	74.00	-25.31	PK
H	4874	65.46	50.67	6.89	31.38	53.06	74.00	-20.94	PK
H	4874	54.53	50.67	6.89	31.38	42.13	54.00	-11.87	AV
H	7311	68.36	50.02	7.24	36.63	62.21	74.00	-11.79	PK
H	7311	46.38	50.02	7.24	36.63	40.23	54.00	-13.77	AV
H	16087	47.45	51.53	11.34	41.52	48.78	74.00	-25.22	PK
operation frequency:2462									
V	4924	67.35	50.79	6.83	31.36	54.75	74.00	-19.25	PK
V	4924	54.58	50.79	6.83	31.36	41.98	54.00	-12.02	AV
V	7386	68.50	50.11	7.25	36.58	62.22	74.00	-11.78	PK
V	7386	45.94	50.11	7.25	36.58	39.66	54.00	-14.34	AV
V	16087	48.62	51.53	11.34	41.52	49.95	74.00	-24.05	PK
H	4924	68.43	50.79	6.83	31.36	55.83	74.00	-18.17	PK
H	4924	56.22	50.79	6.83	31.36	43.62	54.00	-10.38	AV
H	7386	67.90	50.11	7.25	36.58	61.62	74.00	-12.38	PK
H	7386	48.77	50.11	7.25	36.58	42.49	54.00	-11.51	AV
H	16087	50.15	51.53	11.34	41.52	51.48	74.00	-22.52	PK

Remark:

1. Emission Level = Meter Reading + Antenna Factor + Cable Loss – Pre-amplifier, Margin= Emission Level - Limit
2. If peak below the average limit, the average emission was no test.
3. The amplitude of spurious emissions which are attenuated by more than 20dB below the permissible value has no need to be reported.



802.11g

Polar (H/V)	Frequency	Meter Reading	Pre-amplifier	Cable Loss	Antenna Factor	Emission Level	Limits	Margin	Detector Type
	(MHz)	(dBuV)	(dB)	(dB)	(dB/m)	(dBuV/m)	(dBuV/m)	(dB)	
operation frequency:2412									
V	4824	65.53	50.65	6.88	31.29	53.05	74.00	-20.95	PK
V	4824	54.76	50.65	6.88	31.29	42.28	54.00	-11.72	AV
V	7236	66.25	49.98	7.16	36.63	60.06	74.00	-13.94	PK
V	7236	46.69	49.98	7.16	36.63	40.50	54.00	-13.50	AV
V	16087	49.94	51.53	11.34	41.52	51.27	74.00	-22.73	PK
H	4824	66.46	50.65	6.88	31.29	53.98	74.00	-20.02	PK
H	4824	52.51	50.65	6.88	31.29	40.03	54.00	-13.97	AV
H	7236	66.29	49.98	7.16	36.63	60.10	74.00	-13.90	PK
H	7236	47.86	49.98	7.16	36.63	41.67	54.00	-12.33	AV
H	16087	47.94	51.53	11.34	41.52	49.27	74.00	-24.73	PK
operation frequency:2437									
V	4874	66.84	50.67	6.89	31.38	54.44	74.00	-19.56	PK
V	4874	55.14	50.67	6.89	31.38	42.74	54.00	-11.26	AV
V	7311	65.89	50.02	7.24	36.63	59.74	74.00	-14.26	PK
V	7311	45.87	50.02	7.24	36.63	39.72	54.00	-14.28	AV
V	16087	48.00	51.53	11.34	41.52	49.33	74.00	-24.67	PK
H	4874	65.62	50.67	6.89	31.38	53.22	74.00	-20.78	PK
H	4874	55.20	50.67	6.89	31.38	42.80	54.00	-11.20	AV
H	7311	65.17	50.02	7.24	36.63	59.02	74.00	-14.98	PK
H	7311	47.47	50.02	7.24	36.63	41.32	54.00	-12.68	AV
H	16087	47.73	51.53	11.34	41.52	49.06	74.00	-24.94	PK
operation frequency:2462									
V	4924	66.96	50.79	6.83	31.36	54.36	74.00	-19.64	PK
V	4924	55.61	50.79	6.83	31.36	43.01	54.00	-10.99	AV
V	7386	66.78	50.11	7.25	36.58	60.50	74.00	-13.50	PK
V	7386	47.06	50.11	7.25	36.58	40.78	54.00	-13.22	AV
V	16087	46.55	51.53	11.34	41.52	47.88	74.00	-26.12	PK
H	4924	65.51	50.79	6.83	31.36	52.91	74.00	-21.09	PK
H	4924	54.00	50.79	6.83	31.36	41.40	54.00	-12.60	AV
H	7386	64.40	50.11	7.25	36.58	58.12	74.00	-15.88	PK
H	7386	45.14	50.11	7.25	36.58	38.86	54.00	-15.14	AV
H	16087	46.58	51.53	11.34	41.52	47.91	74.00	-26.09	PK

Remark:

1. Emission Level = Meter Reading + Antenna Factor + Cable Loss – Pre-amplifier, Margin= Emission Level - Limit
2. If peak below the average limit, the average emission was no test.
3. The amplitude of spurious emissions which are attenuated by more than 20dB below the permissible value has no need to be reported.



802.11n HT20

Polar (H/V)	Frequency	Meter Reading	Pre-amplifier	Cable Loss	Antenna Factor	Emission Level	Limits	Margin	Detector Type
	(MHz)	(dBuV)	(dB)	(dB)	(dB/m)	(dBuV/m)	(dBuV/m)	(dB)	
operation frequency:2412									
V	4824	65.99	50.65	6.88	31.29	53.51	74.00	-20.49	PK
V	4824	55.10	50.65	6.88	31.29	42.62	54.00	-11.38	AV
V	7236	66.14	49.98	7.16	36.63	59.95	74.00	-14.05	PK
V	7236	46.20	49.98	7.16	36.63	40.01	54.00	-13.99	AV
V	16087	46.32	51.53	11.34	41.52	47.65	74.00	-26.35	PK
H	4824	66.66	50.65	6.88	31.29	54.18	74.00	-19.82	PK
H	4824	55.45	50.65	6.88	31.29	42.97	54.00	-11.03	AV
H	7236	64.25	49.98	7.16	36.63	58.06	74.00	-15.94	PK
H	7236	47.11	49.98	7.16	36.63	40.92	54.00	-13.08	AV
H	16087	46.98	51.53	11.34	41.52	48.31	74.00	-25.69	PK
operation frequency:2437									
V	4874	66.69	50.67	6.89	31.38	54.29	74.00	-19.71	PK
V	4874	54.81	50.67	6.89	31.38	42.41	54.00	-11.59	AV
V	7311	64.93	50.02	7.24	36.63	58.78	74.00	-15.22	PK
V	7311	47.15	50.02	7.24	36.63	41.00	54.00	-13.00	AV
V	16087	47.23	51.53	11.34	41.52	48.56	74.00	-25.44	PK
H	4874	66.04	50.67	6.89	31.38	53.64	74.00	-20.36	PK
H	4874	54.34	50.67	6.89	31.38	41.94	54.00	-12.06	AV
H	7311	65.77	50.02	7.24	36.63	59.62	74.00	-14.38	PK
H	7311	46.69	50.02	7.24	36.63	40.54	54.00	-13.46	AV
H	16087	46.97	51.53	11.34	41.52	48.30	74.00	-25.70	PK
operation frequency:2462									
V	4924	67.49	50.79	6.83	31.36	54.89	74.00	-19.11	PK
V	4924	54.92	50.79	6.83	31.36	42.32	54.00	-11.68	AV
V	7386	64.61	50.11	7.25	36.58	58.33	74.00	-15.67	PK
V	7386	46.71	50.11	7.25	36.58	40.43	54.00	-13.57	AV
V	16087	48.82	51.53	11.34	41.52	50.15	74.00	-23.85	PK
H	4924	67.18	50.79	6.83	31.36	54.58	74.00	-19.42	PK
H	4924	54.46	50.79	6.83	31.36	41.86	54.00	-12.14	AV
H	7386	65.54	50.11	7.25	36.58	59.26	74.00	-14.74	PK
H	7386	47.27	50.11	7.25	36.58	40.99	54.00	-13.01	AV
H	16087	47.77	51.53	11.34	41.52	49.10	74.00	-24.90	PK

Remark:

1. Emission Level = Meter Reading + Antenna Factor + Cable Loss – Pre-amplifier, Margin= Emission Level - Limit
2. If peak below the average limit, the average emission was no test.
3. The amplitude of spurious emissions which are attenuated by more than 20dB below the permissible value has no need to be reported.



3.3 RADIATED BAND EMISSION MEASUREMENT

3.3.1 TEST REQUIREMENT:

FCC Part15 C Section 15.209 and 15.205

LIMITS OF RADIATED EMISSION MEASUREMENT (Above 1000MHz)

FREQUENCY (MHz)	Limit (dBuV/m) (at 3M)	
	PEAK	AVERAGE
Above 1000	74	54

Notes:

- (1) The limit for radiated test was performed according to FCC PART 15C.
- (2) The tighter limit applies at the band edges.
- (3) Emission level (dBuV/m)=20log Emission level (uV/m).

Spectrum Parameter	Setting
Attenuation	Auto
Start Frequency	2300MHz
Stop Frequency	2520
RB / VB (emission in restricted band)	1 MHz / 1 MHz for Peak, 1 MHz / 10Hz for Average

3.3.2 TEST PROCEDURE

Above 1GHz test procedure as below:

- a. 1. The EUT was placed on the top of a rotating table 0.1 meters above the ground at a 3 meter camber. The table was rotated 360 degrees to determine the position of the highest radiation.
- b. The EUT was set 3 meters away from the interference-receiving antenna, which was mounted on the top of a variable-height antenna tower.
- c. The antenna height is varied from one meter to four meters above the ground to determine the maximum value of the field strength. Both horizontal and vertical polarizations of the antenna are set to make the measurement.
- d. For each suspected emission, the EUT was arranged to its worst case and then the antenna was tuned to heights from 1 meter to 4 meters and the rota table was turned from 0 degrees to 360 degrees to find the maximum reading.
- e. The test-receiver system was set to Peak Detect Function and Specified Bandwidth with Maximum Hold Mode.
- f. If the emission level of the EUT in peak mode was 10dB lower than the limit specified, then testing could be stopped and the peak values of the EUT would be reported. Otherwise the emissions that did not have 10dB margin would be re-tested one by one using peak, quasi-peak or average method as specified and then reported in a data sheet.
- g. Test the EUT in the lowest channel,the Highest channel

Note:

Both horizontal and vertical antenna polarities were tested and performed pretest to three orthogonal axis. The worst case emissions were reported

3.3.3 DEVIATION FROM TEST STANDARD

No deviation

3.3.4 TEST SETUP

Radiated Emission Test-Up Frequency Above 1GHz

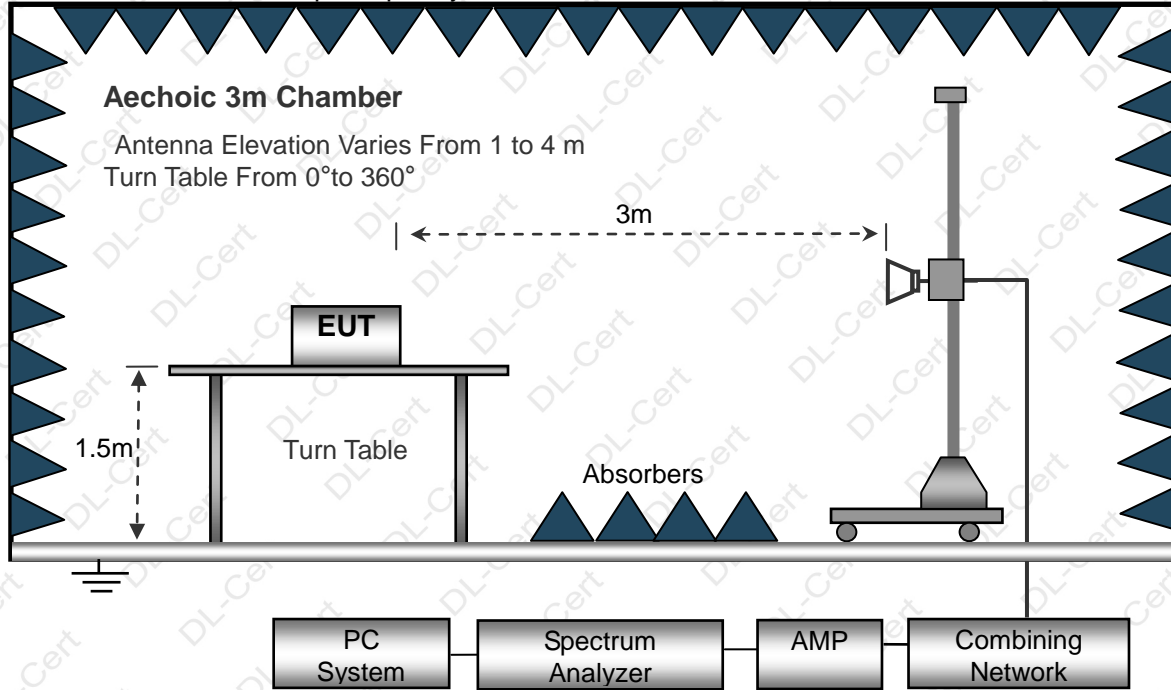

3.3.5 EUT OPERATING CONDITIONS

The EUT tested system was configured as the statements of 2.3 Unless otherwise a special operating condition is specified in the follows during the testing.



3.3.6 TEST RESULT

802.11b

Polar (H/V)	Frequency	Meter Reading	Pre-amplifier	Cable Loss	Antenna Factor	Emission Level	Limits	Margin	Detector Type
	(MHz)	(dBuV)	(dB)	(dB)	(dB/m)	(dBuV/m)	(dBuV/m)	(dB)	
operation frequency:2412									
V	2390	77.18	52.12	2.73	27.38	55.17	74.00	-18.83	PK
V	2390	64.48	52.12	2.73	27.38	42.47	54.00	-11.53	AV
V	2400	77.29	52.16	2.78	27.41	55.32	74.00	-18.68	PK
V	2400	65.06	52.16	2.78	27.41	43.09	54.00	-10.91	AV
H	2390	77.83	52.12	2.73	27.38	55.82	74.00	-18.18	PK
H	2390	64.16	52.12	2.73	27.38	42.15	54.00	-11.85	AV
H	2400	77.61	52.16	2.78	27.41	55.64	74.00	-18.36	PK
H	2400	64.51	52.16	2.78	27.41	42.54	54.00	-11.46	AV

Polar (H/V)	Frequency	Meter Reading	Pre-amplifier	Cable Loss	Antenna Factor	Emission Level	Limits	Margin	Detector Type
	(MHz)	(dBuV)	(dB)	(dB)	(dB/m)	(dBuV/m)	(dBuV/m)	(dB)	
operation frequency:2462									
V	2483.5	76.59	52.23	2.86	27.44	54.66	74.00	-19.34	PK
V	2483.5	64.98	52.23	2.86	27.44	43.05	54.00	-10.95	AV
V	2500	76.64	52.26	2.88	27.49	54.75	74.00	-19.25	PK
V	2500	64.45	52.26	2.88	27.49	42.56	54.00	-11.44	AV
H	2483.5	76.92	52.23	2.86	27.44	54.99	74.00	-19.01	PK
H	2483.5	65.65	52.23	2.86	27.44	43.72	54.00	-10.28	AV
H	2500	76.48	52.26	2.88	27.49	54.59	74.00	-19.41	PK
H	2500	65.39	52.26	2.88	27.49	43.50	54.00	-10.50	AV

Remark:

1. Emission Level = Meter Reading + Antenna Factor + Cable Loss – Pre-amplifier, Margin= Emission Level - Limit
2. If peak below the average limit, the average emission was no test.
3. The amplitude of spurious emissions which are attenuated by more than 20dB below the permissible value has no need to be reported.



802.11g

Polar (H/V)	Frequency	Meter Reading	Pre-amplifier	Cable Loss	Antenna Factor	Emission Level	Limits	Margin	Detector Type
	(MHz)	(dBuV)	(dB)	(dB)	(dB/m)	(dBuV/m)	(dBuV/m)	(dB)	
operation frequency:2412									
V	2390	77.19	52.12	2.73	27.38	55.18	74.00	-18.82	PK
V	2390	63.91	52.12	2.73	27.38	41.90	54.00	-12.10	AV
V	2400	76.90	52.16	2.78	27.41	54.93	74.00	-19.07	PK
V	2400	65.53	52.16	2.78	27.41	43.56	54.00	-10.44	AV
H	2390	77.67	52.12	2.73	27.38	55.66	74.00	-18.34	PK
H	2390	65.41	52.12	2.73	27.38	43.40	54.00	-10.60	AV
H	2400	77.08	52.16	2.78	27.41	55.11	74.00	-18.89	PK
H	2400	65.76	52.16	2.78	27.41	43.79	54.00	-10.21	AV

Polar (H/V)	Frequency	Meter Reading	Pre-amplifier	Cable Loss	Antenna Factor	Emission Level	Limits	Margin	Detector Type
	(MHz)	(dBuV)	(dB)	(dB)	(dB/m)	(dBuV/m)	(dBuV/m)	(dB)	
operation frequency:2462									
V	2483.5	76.45	52.23	2.86	27.44	54.52	74.00	-19.48	PK
V	2483.5	64.98	52.23	2.86	27.44	43.05	54.00	-10.95	AV
V	2500	76.12	52.26	2.88	27.49	54.23	74.00	-19.77	PK
V	2500	64.98	52.26	2.88	27.49	43.09	54.00	-10.91	AV
H	2483.5	76.57	52.23	2.86	27.44	54.64	74.00	-19.36	PK
H	2483.5	65.07	52.23	2.86	27.44	43.14	54.00	-10.86	AV
H	2500	76.17	52.26	2.88	27.49	54.28	74.00	-19.72	PK
H	2500	65.74	52.26	2.88	27.49	43.85	54.00	-10.15	AV

Remark:

1. Emission Level = Meter Reading + Antenna Factor + Cable Loss – Pre-amplifier, Margin= Emission Level - Limit
2. If peak below the average limit, the average emission was no test.
3. The amplitude of spurious emissions which are attenuated by more than 20dB below the permissible value has no need to be reported.



802.11n HT20

Polar (H/V)	Frequency	Meter Reading	Pre-amplifier	Cable Loss	Antenna Factor	Emission Level	Limits	Margin	Detector Type
	(MHz)	(dBuV)	(dB)	(dB)	(dB/m)	(dBuV/m)	(dBuV/m)	(dB)	
operation frequency:2412									
V	2390	76.13	52.12	2.73	27.38	54.12	74.00	-19.88	PK
V	2390	64.79	52.12	2.73	27.38	42.78	54.00	-11.22	AV
V	2400	76.82	52.16	2.78	27.41	54.85	74.00	-19.15	PK
V	2400	64.84	52.16	2.78	27.41	42.87	54.00	-11.13	AV
H	2390	76.74	52.12	2.73	27.38	54.73	74.00	-19.27	PK
H	2390	64.81	52.12	2.73	27.38	42.80	54.00	-11.20	AV
H	2400	76.47	52.16	2.78	27.41	54.50	74.00	-19.50	PK
H	2400	64.95	52.16	2.78	27.41	42.98	54.00	-11.02	AV

Polar (H/V)	Frequency	Meter Reading	Pre-amplifier	Cable Loss	Antenna Factor	Emission Level	Limits	Margin	Detector Type
	(MHz)	(dBuV)	(dB)	(dB)	(dB/m)	(dBuV/m)	(dBuV/m)	(dB)	
operation frequency:2462									
V	2483.5	76.81	52.23	2.86	27.44	54.88	74.00	-19.12	PK
V	2483.5	65.44	52.23	2.86	27.44	43.51	54.00	-10.49	AV
V	2500	75.87	52.26	2.88	27.49	53.98	74.00	-20.02	PK
V	2500	65.20	52.26	2.88	27.49	43.31	54.00	-10.69	AV
H	2483.5	77.45	52.23	2.86	27.44	55.52	74.00	-18.48	PK
H	2483.5	65.50	52.23	2.86	27.44	43.57	54.00	-10.43	AV
H	2500	76.83	52.26	2.88	27.49	54.94	74.00	-19.06	PK
H	2500	66.24	52.26	2.88	27.49	44.35	54.00	-9.65	AV

Remark:

1. Emission Level = Meter Reading + Antenna Factor + Cable Loss – Pre-amplifier,
Margin= Emission Level - Limit
2. If peak below the average limit, the average emission was no test.
3. The amplitude of spurious emissions which are attenuated by more than 20dB below the permissible value has no need to be reported.



3.4 CONDUCTED BAND EDGE EMISSION&CONDUCTED SPURIOUS EMISSIONS MEASUREMENT

Test Requirement:	FCC Part15 C Section 15.247 (d)
Test Method:	KDB558074 D0115.247 Meas Guidance v05r02

3.4.1 APPLICABLE STANDARD

in any 100 kHz bandwidth outside the frequency bands in which the spread spectrum intentional radiator is operating, the radio frequency power that is produced by the intentional radiator shall be at least 20dB below that in the 100kHz bandwidth within the band that contains the highest level of the desired power, In addition, radiated emissions which fall in the restricted bands, as defined in§15.205(a), must also comply with the radiated emission limits specified in15.209(a).

If the transmitter complies with the conducted power limits based on the use of RMS averaging over a time interval, as permitted under paragraph (b)(3) of this section, the attenuation required under this paragraph shall be 30 dB instead of 20 dB.

3.4.2 TEST PROCEDURE

Using the following spectrum analyzer setting:

Set the RBW = 100KHz.

Set the VBW = 300KHz.

Sweep time = auto couple.

Detector function = peak.

Trace mode = max hold.

Allow trace to fully stabilize.

3.4.3 DEVIATION FROM STANDARD

No deviation.

3.4.4 TEST SETUP



3.4.5 EUT OPERATION CONDITIONS

The EUT tested system was configured as the statements of 2.4 Unless otherwise a special operating condition is specified in the follows during the testing.

3.4.6 TEST RESULTS



For Conducted
802.11b

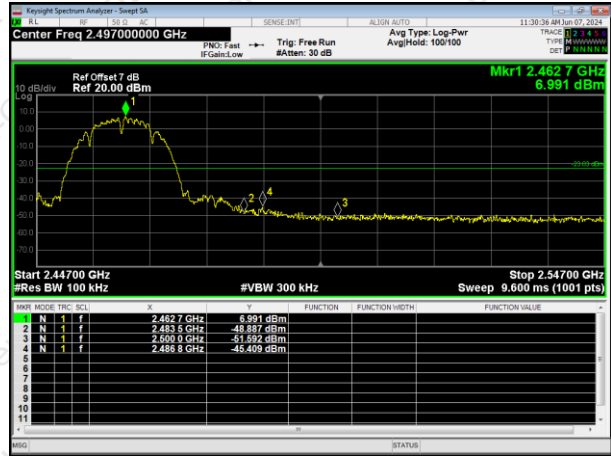
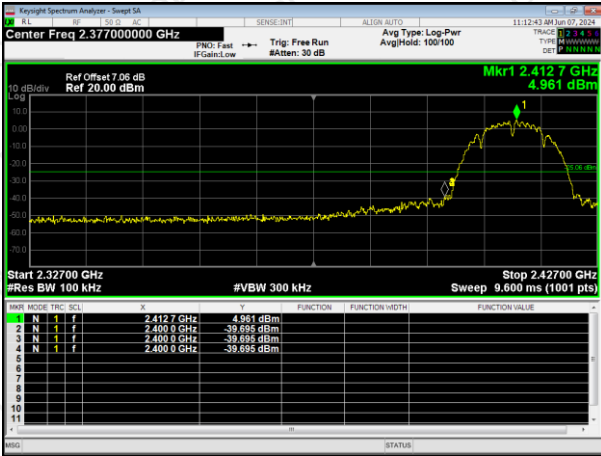

802.11g

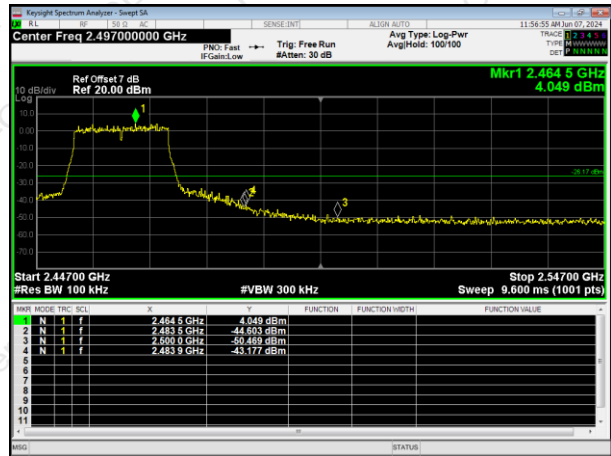
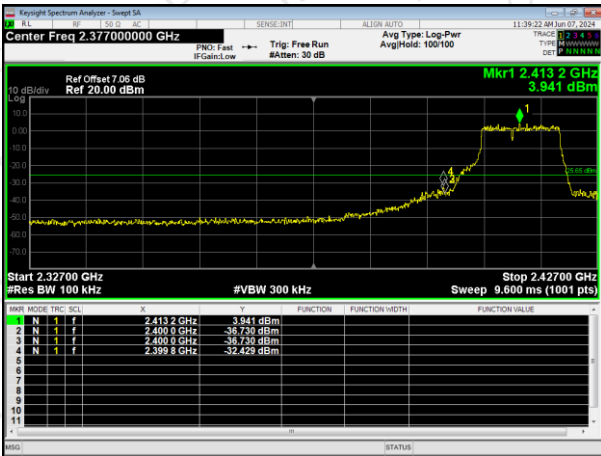

802.11n HT20

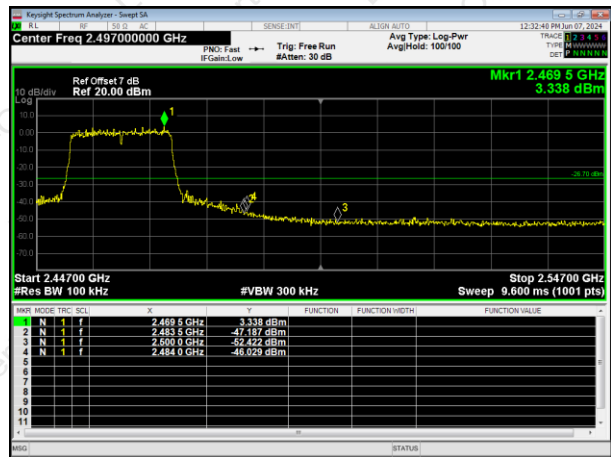
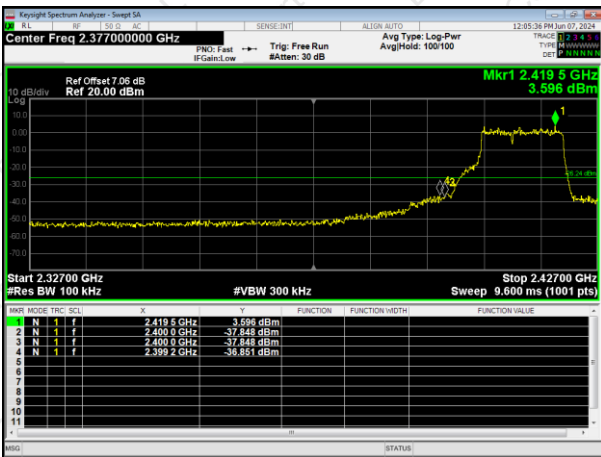



For Conducted

During the test, pre-scan the all modulation, and found the 802.11b mode which it is worse case.

Test channel: Lowest channel

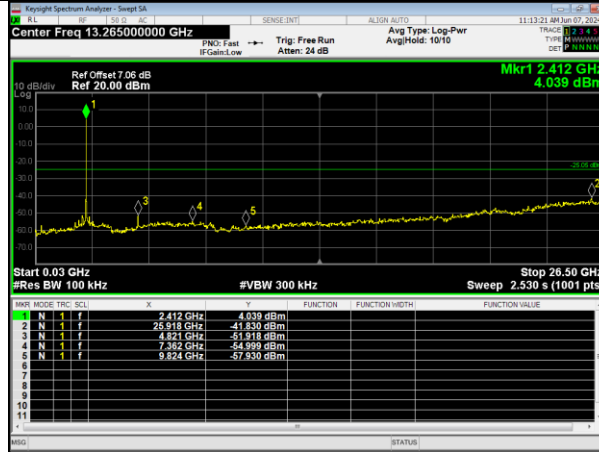

0.03GHz~26.5GHz

Test channel: Middle channel

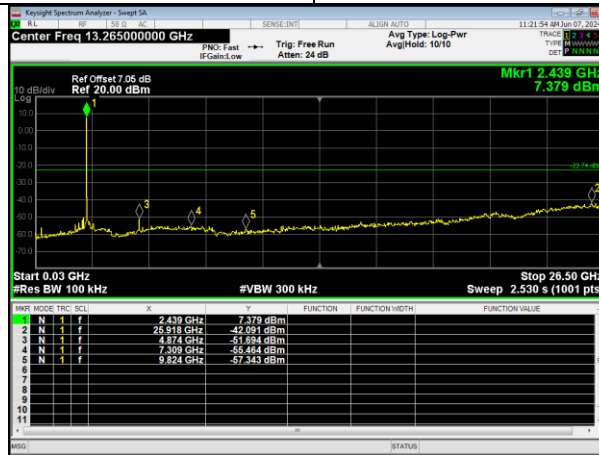

0.03GHz~26.5GHz

Test channel: Highest channel

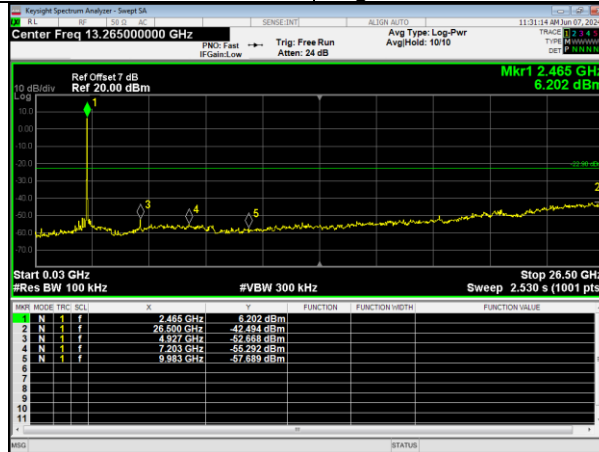

0.03GHz~26.5GHz



4. AVERAGE OUTPUT POWER

4.1 APPLIED PROCEDURES / LIMIT

FCC Part15 (15.247) , Subpart C				
Section	Test Item	Limit	Frequency Range (MHz)	Result
15.247 (b)(3)	Average Output Power	1 watt or 30dBm	2400-2483.5	PASS

4.1.1 TEST PROCEDURE

- The EUT was directly connected to the spectrum analyzer and antenna output port as show in the block diagram below,
- Set span to at least 1.5 times the OBW.
- Set RBW = 1% to 5% of the OBW, not to exceed 1 MHz.
- Set VBW \geq [3 \times RBW].
- Number of points in sweep \geq [2 \times span / RBW]. (This gives bin-to-bin spacing \leq RBW / 2, so that narrowband signals are not lost between frequency bins.)
- Sweep time = auto.
- Detector = RMS (i.e., power averaging), if available. Otherwise, use sample detector mode.
- If transmit duty cycle < 98%, use a sweep trigger with the level set to enable triggering only on full power pulses. The transmitter shall operate at the maximum power control level for the entire duration of every sweep. If the EUT transmits continuously (i.e., with no OFF intervals) or at duty cycle \geq 98%, and if each transmission is entirely at the maximum power control level, then the trigger shall be set to "free run."
- Trace average at least 100 traces in power averaging (rms) mode.
- Compute power by integrating the spectrum across the OBW of the signal using the instrument's band power measurement function, with band limits set equal to the OBW band edges. If the instrument does not have a band power function, sum the spectrum levels (in power units) at intervals equal to the RBW extending across the entire OBW of the spectrum.

4.1.2 DEVIATION FROM STANDARD

No deviation.

4.1.3 TEST SETUP

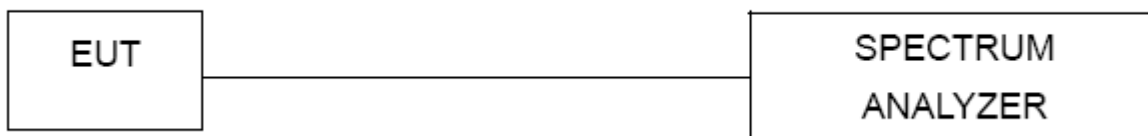

4.1.4 EUT OPERATION CONDITIONS

The EUT tested system was configured as the statements of 2.4 Unless otherwise a special operating condition is specified in the follows during the testing.

**4.1.5 TEST RESULTS**

Temperature:	25 °C	Relative Humidity:	60%
Pressure:	1012 hPa	Test Voltage :	AC 120V/60Hz

Mode	Test Channel	Average Output Power (dBm)	LIMIT (dBm)
802.11b	Low	15.795	30.00
	Middle	17.671	30.00
	High	17.156	30.00
802.11g	Low	15.002	30.00
	Middle	15.974	30.00
	High	15.486	30.00
802.11n HT20	Low	14.121	30.00
	Middle	14.912	30.00
	High	14.400	30.00

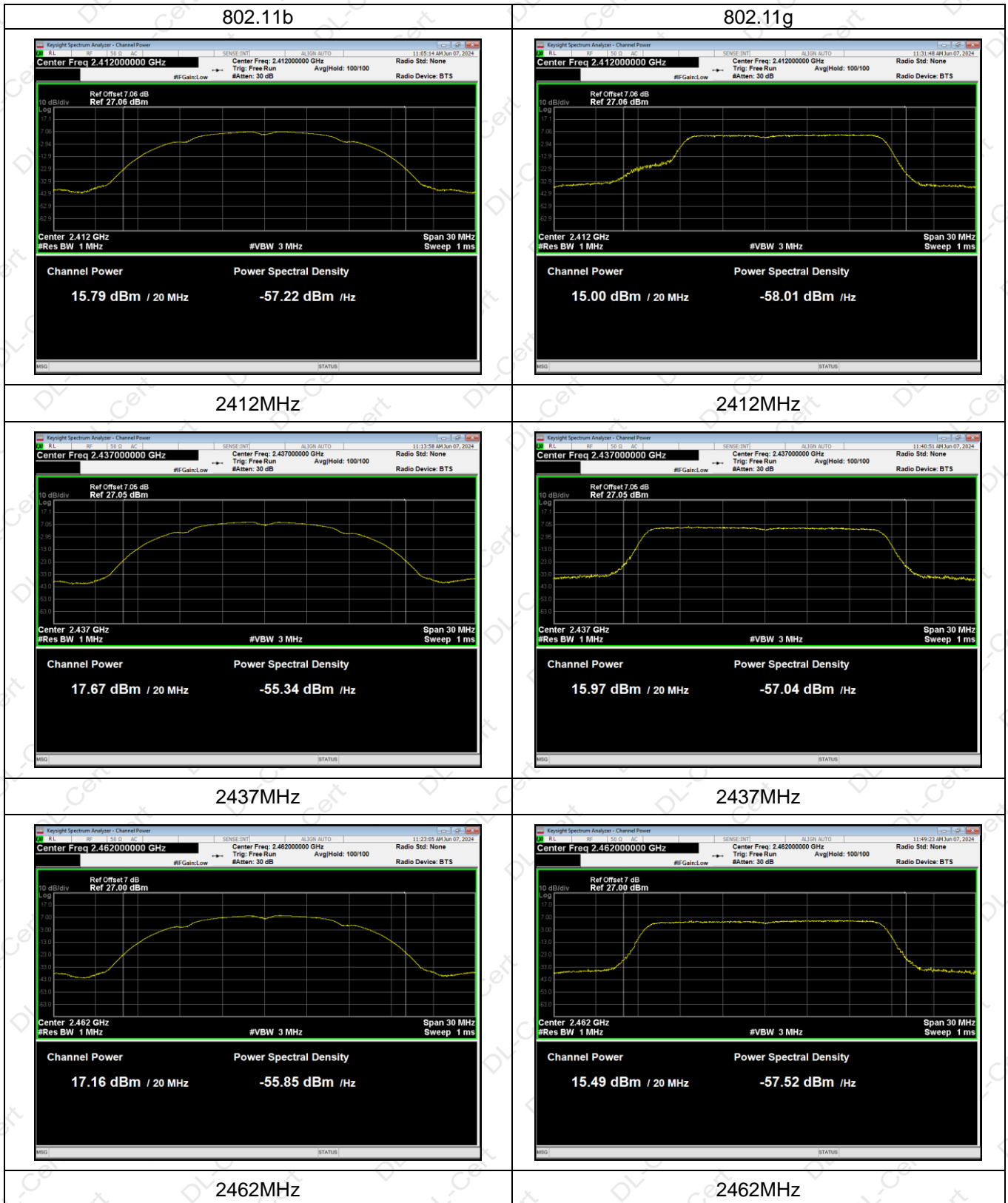



802.11n HT20

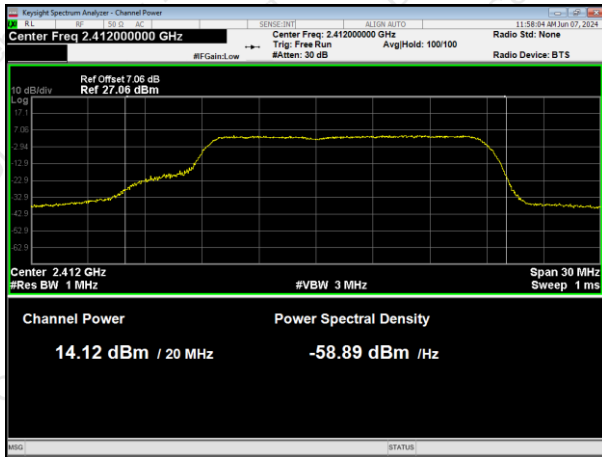

2412MHz

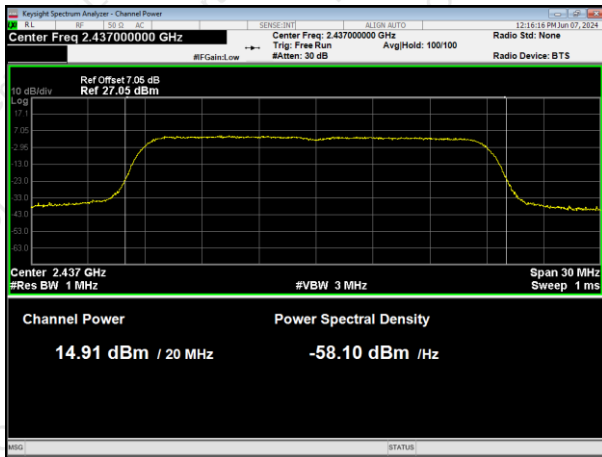

2437MHz

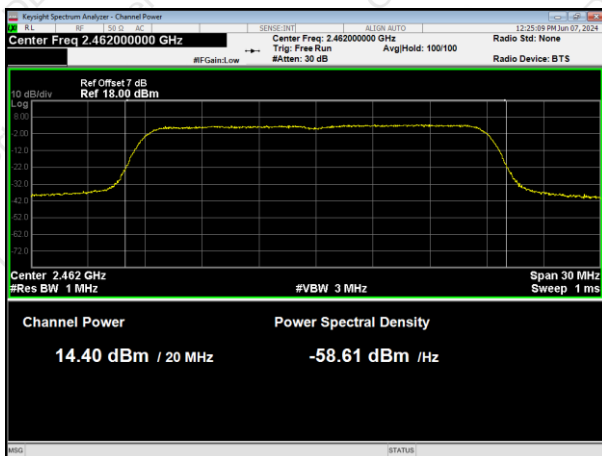

2462MHz



5. POWER SPECTRAL DENSITY TEST

5.1 APPLIED PROCEDURES / LIMIT

FCC Part15 (15.247) , Subpart C				
Section	Test Item	Limit	Frequency Range (MHz)	Result
15.247	Power Spectral Density	8 dBm (in any 3KHz)	2400-2483.5	PASS

Spectrum Parameters	Setting
Attenuation	Auto
Span Frequency	= the frequency band of operation
RB	RBW \geq 3kHz
VB	VBW \geq 3RBW
Detector	power averaging (rms) or sample detector (when rms not available).
Trace	Max Hold
Sweep Time	Auto

5.1.1 TEST PROCEDURE

- The EUT was directly connected to the spectrum analyzer and antenna output port as show in the block diagram below,

5.1.2 DEVIATION FROM STANDARD

No deviation.

5.1.3 TEST SETUP



5.1.4 EUT OPERATION CONDITIONS

The EUT tested system was configured as the statements of 2.4 Unless otherwise a special operating condition is specified in the follows during the testing.

**5.1.5 TEST RESULTS**

Mode	Test Channel	Reading Level (dBm/3kHz)	Limit (dBm/3kHz)	Result
802.11b	Low	-10.155	8	PASS
	Middle	-5.705	8	PASS
	High	-6.079	8	PASS
802.11g	Low	-18.235	8	PASS
	Middle	-18.034	8	PASS
	High	-18.487	8	PASS
802.11n20	Low	-18.623	8	PASS
	Middle	-18.734	8	PASS
	High	-19.217	8	PASS

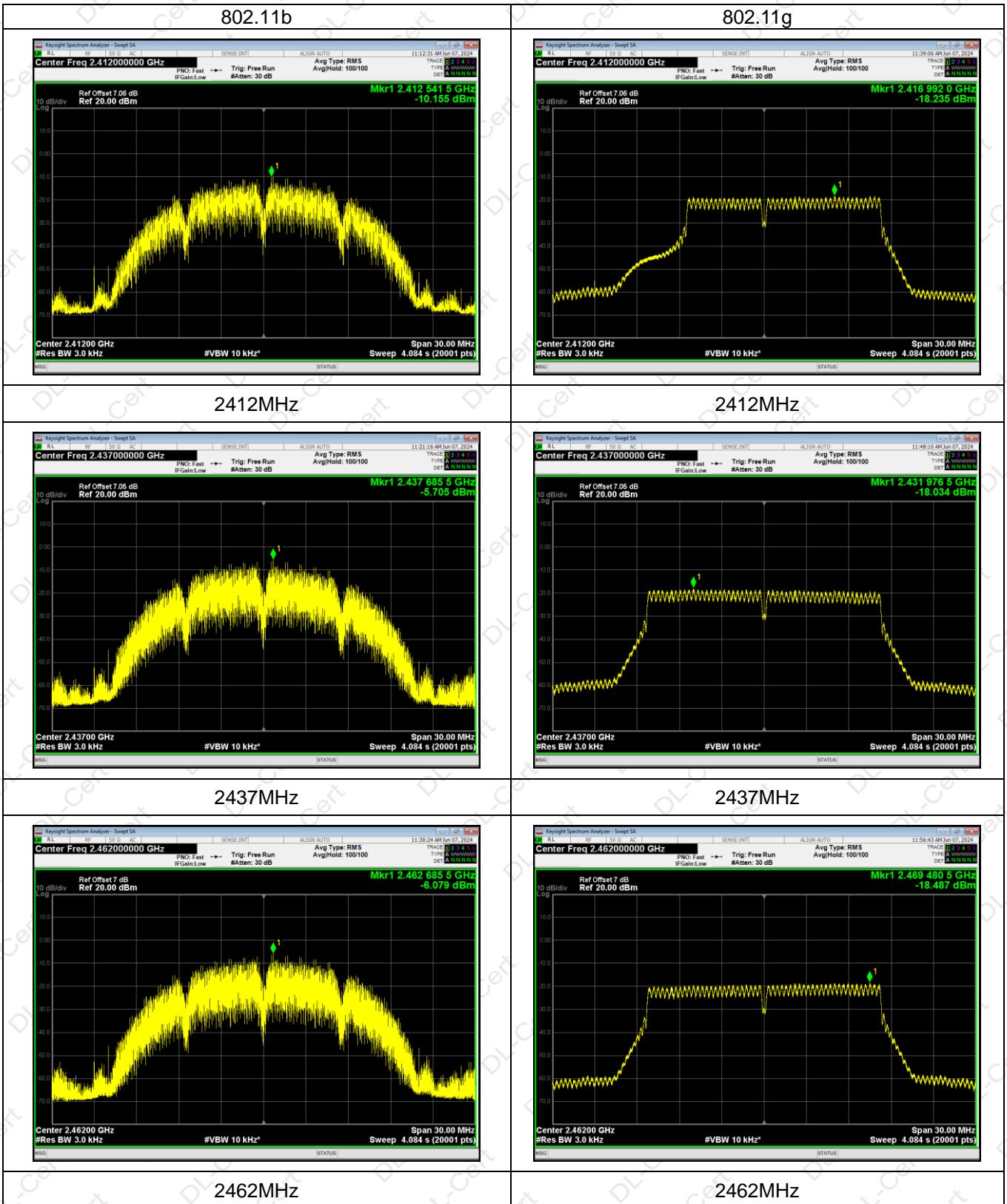



802.11n HT20

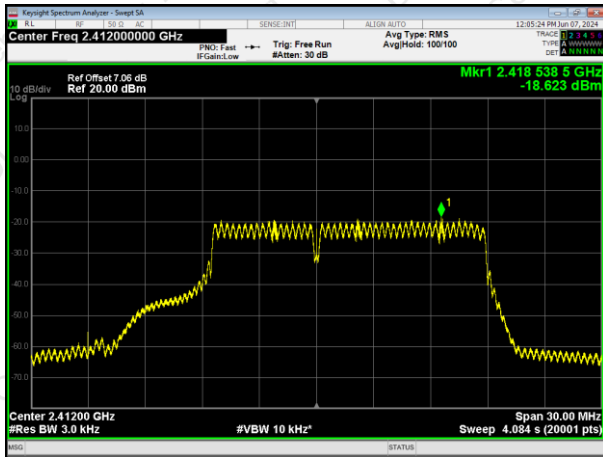

2412MHz

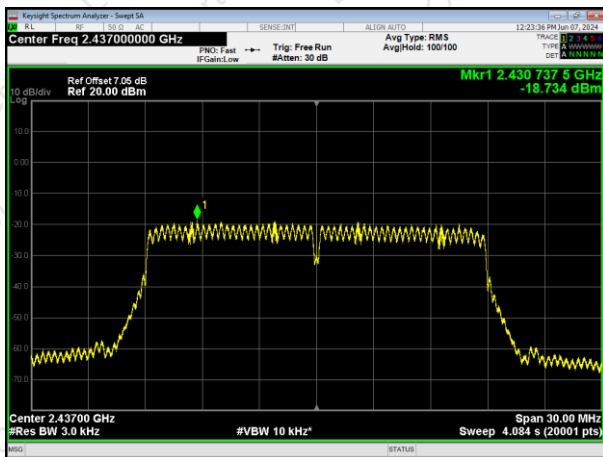

2437MHz

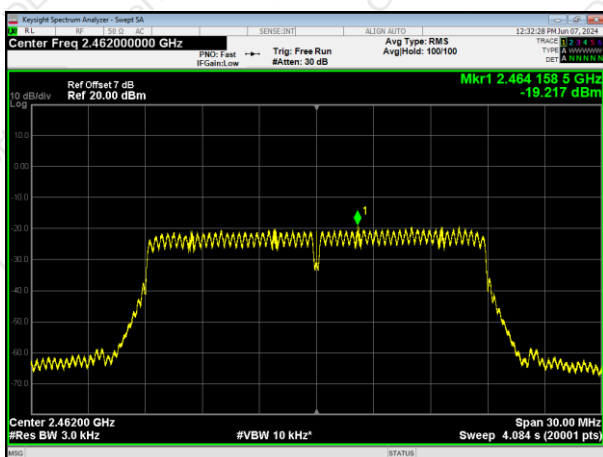

2462MHz



6. 6DB BANDWIDTH TEST

6.1 APPLIED PROCEDURES / LIMIT

FCC Part15 (15.247) , Subpart C				
Section	Test Item	Limit	Frequency Range(MHz)	Result
15.247(a)(2)	Bandwidth	>= 500KHz (6dB bandwidth)	2400-2483.5	PASS

6.1.1 TEST PROCEDURE

1. Set RBW = 100 kHz.
2. Set the video bandwidth (VBW) ≥RBW.
3. Detector = Peak.
4. Trace mode = max hold.
5. Sweep = auto couple.
6. Allow the trace to stabilize.
7. Measure the maximum width of the emission that is constrained by the frequencies associated with the two outermost amplitude points (upper and lower frequencies) that are attenuated by 20 dB relative to the maximum level measured in the fundamental emission.

6.1.2 DEVIATION FROM STANDARD

No deviation.

6.1.3 TEST SETUP



6.1.4 EUT OPERATION CONDITIONS

The EUT tested system was configured as the statements of 2.3 Unless otherwise a special operating condition is specified in the follows during the testing.

**6.1.5 TEST RESULTS**

	Test Channel	6dB Bandwidth (MHz)	Limit (MHz)	Result
802.11b	Low	9.812	0.5	Pass
	Middle	9.760	0.5	Pass
	High	9.543	0.5	Pass
802.11g	Low	13.684	0.5	Pass
	Middle	16.429	0.5	Pass
	High	16.442	0.5	Pass
802.11n HT20	Low	14.217	0.5	Pass
	Middle	17.582	0.5	Pass
	High	17.550	0.5	Pass



802.11b

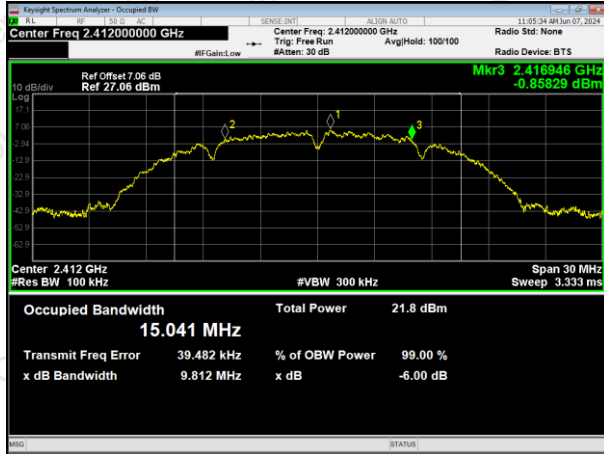

802.11g

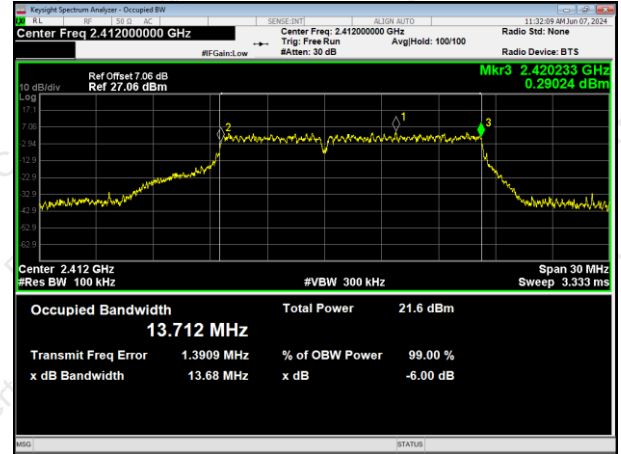

2412MHz

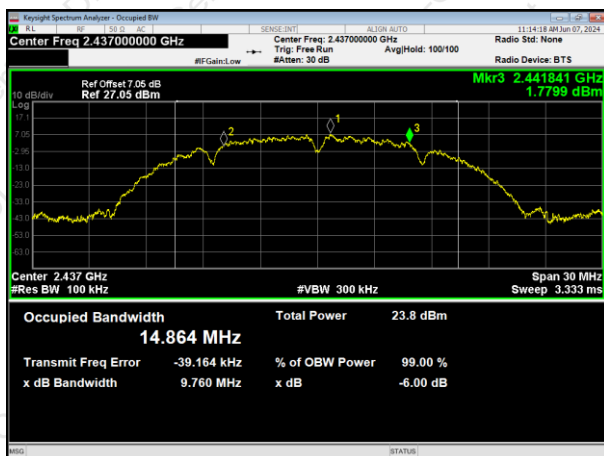

2412MHz

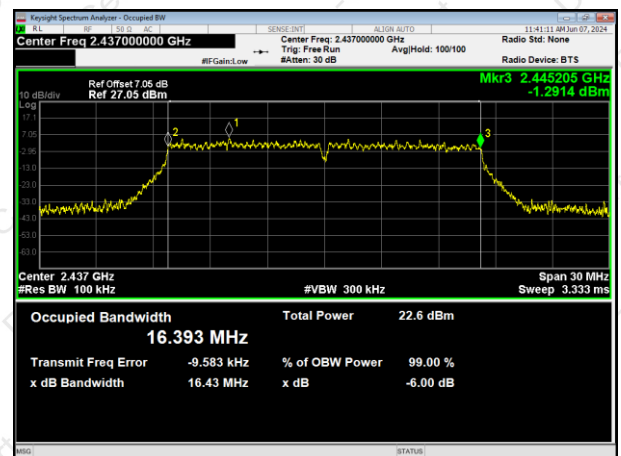

2437MHz

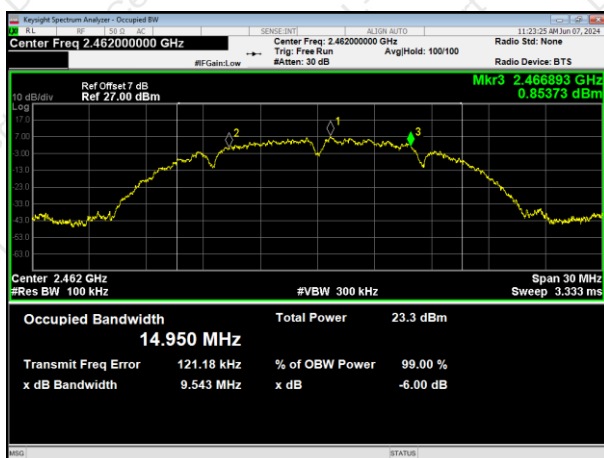

2437MHz

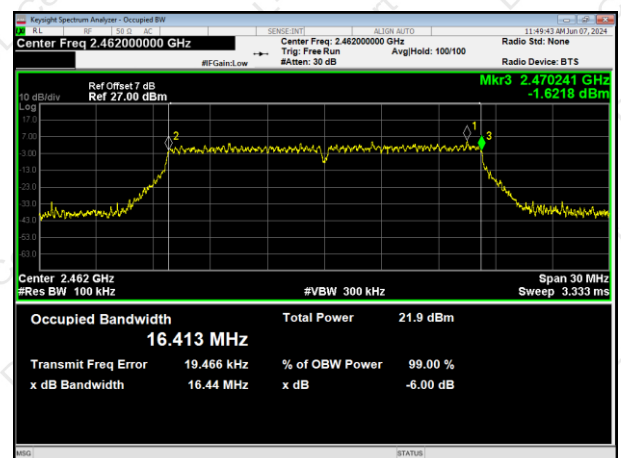

2462MHz

2462MHz



802.11n HT20

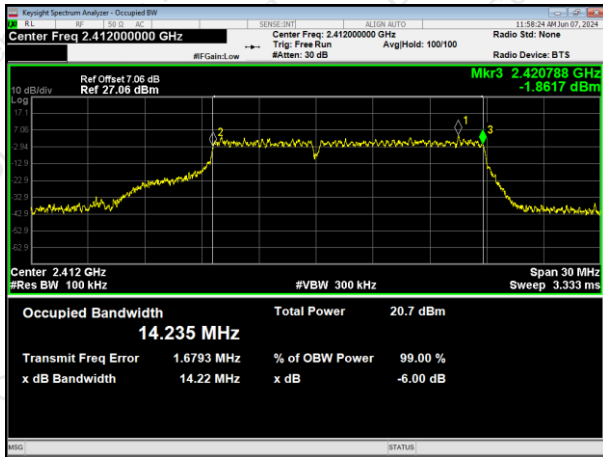

2412MHz

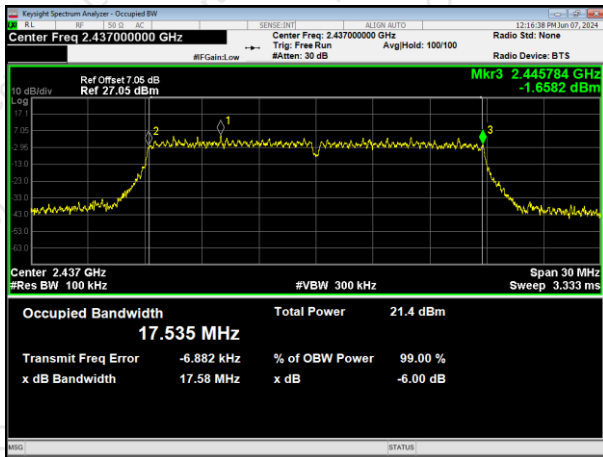

2437MHz

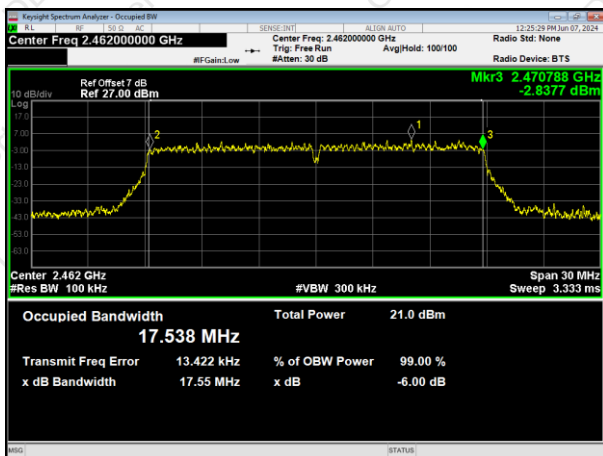

2462MHz



7. ANTENNA REQUIREMENT

7.1 STANDARD REQUIREMENT

15.203 requirement: For intentional device, according to 15.203: an intentional radiator shall be designed to ensure that no antenna other than that furnished by the responsible party shall be used with the device.

7.2 EUT ANTENNA

The EUT antenna is FPC Antenna, It comply with the standard requirement.

8. TEST SEUUP PHOTO

Reference to the appendix I for details.

9. EUT PHOTO

Reference to the appendix II for details.

※※※※※ END OF REPORT ※※※※※