



**M33**  
MilPro Headset  
Tactical Communication & Hearing Protection

User instructions

# QUICK GUIDE:

Fig 1

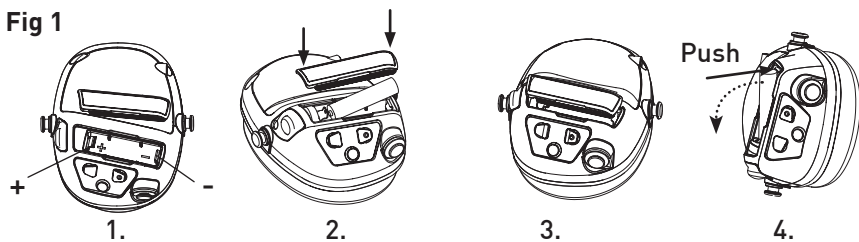


Fig 2

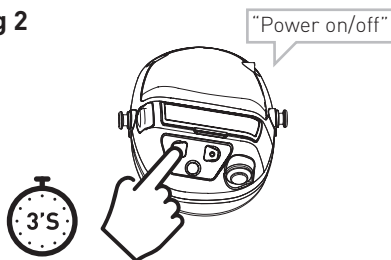


Fig 3

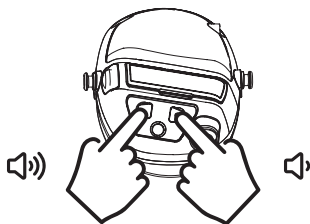


Fig 4

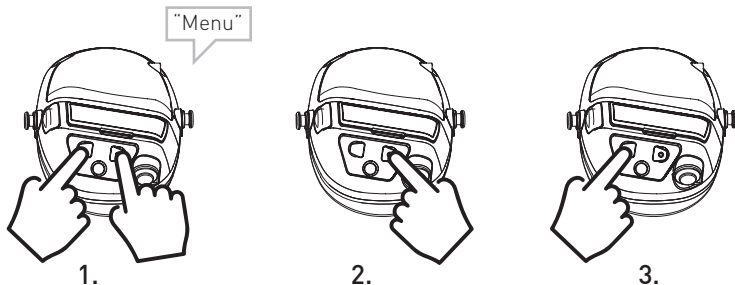


Fig 5 From Power On Mode

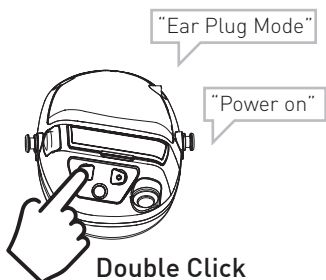
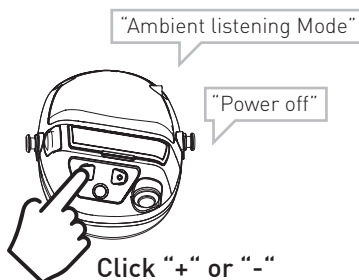
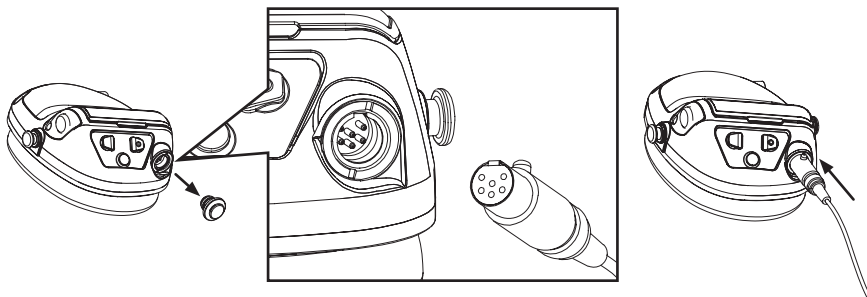


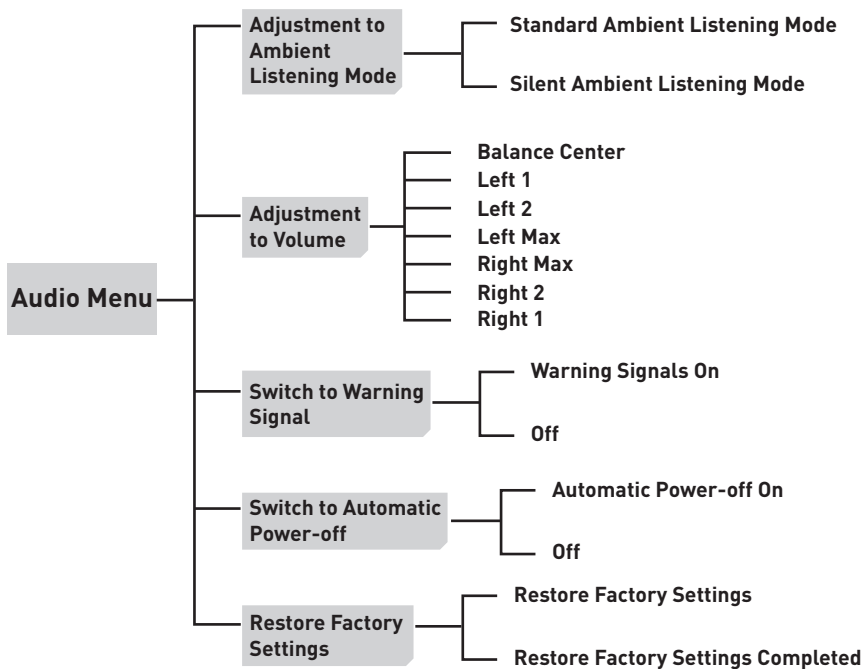
Fig 6 From Power On Mode



**Fig7 Connct PTT**

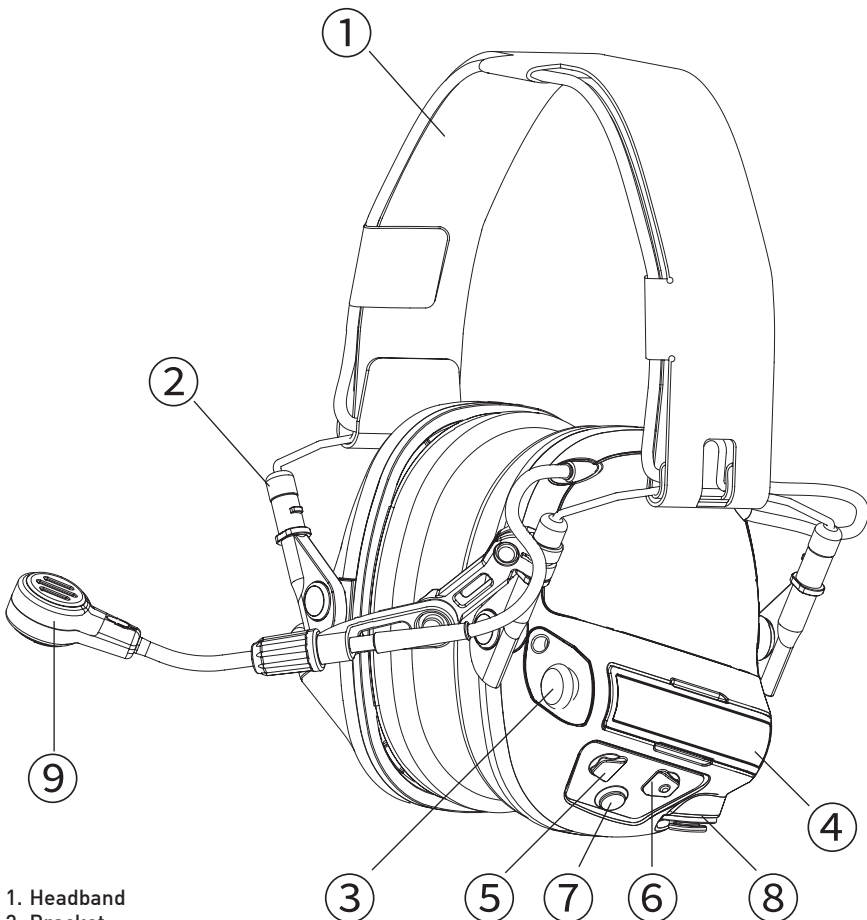


**Fig8**



Congratulations and thanks for your choosing EARMOR®  
EARMOR® Hearing Protectors designed to protect users from harmful noise.

## 2. OVERVIEW



- 1. Headband
- 2. Bracket
- 3. Pickup Microphone
- 4. Battery Holder
- 5. Volume up
- 6. Volume Down
- 7. Bluetooth® Button
- 8. PTT Port
- 9. Boom Mic S10D

### 3. APPROVALS

EARMOR® M33 Milpro Headset are tested and certified according to the following standards:  
 ANSI S3.19-1974  
 EN 352-1: 2020  
 EN 352-4: 2020  
 EN 352-6: 2020  
 EN 352-8: 2020

#### 3.1 Noise Reduction Rating: 23 dB

EARMOR® M33 Milpro Headset Attenuation data, American National Standards Institute specifications: ANSI S3.19-1974

TEST FREQ.(HZ)	125	250	500	1000	2000	3150	4000	6300	8000	NRR
MEAN ATTENUATION(DB)	17.1	18.8	26.8	34.0	32.4	36.6	42.2	43.5	43.0	23
STANDARD DEVEATION(DB)	2.2	2.3	2.6	4.2	2.4	3.3	4.2	3.9	4.5	

#### 3.2 Single Namber Rating: 29dB

EARMOR® M33 Milpro Headset Appendix A Attenuation Data Individual and Summary Attenuation Data for Hearing Protective Devices  
 EN 352-1: 2020

SUBJECT	63	125	250	500	1000	2000	4000	8000	SNR
MEANS	17.7	13.9	20	27	32.6	32.3	42.4	42.8	29
STD.DEV	2.2	2.1	3	2.9	3.8	2.5	4.0	4.1	
MEAN-SD	15.4	11.8	17.0	24.1	28.8	29.7	38.4	38.8	

SNR<sup>m</sup>=30.8  
 SNR<sup>s</sup>=2.0  
 SNR(dB)=29

H84(dB)= 32dB    H<sup>m</sup>= 34.8    H<sup>s</sup>= 2.5  
 M84(dB)= 26dB    M<sup>m</sup>= 28.5    M<sup>s</sup>= 2.2  
 L84(dB)= 19dB    L<sup>m</sup>= 21.1    L<sup>s</sup>= 2.1

### 4. DESCRIPTION

Your hearing and enhance situational awareness and communication in noisy environments. With advanced and multifunctional features, it is suitable for a variety of missions. The voice menu allows you to select the functions you need with ease. Additionally, the U174 download cables can be removed to connect to a NATO standard PTT for command and communication.

## 5. INFORMATIONS

For the best protection, ear cushion sealing ring should seal firmly against head, Anything that interferes with the seal --- such as long hair(pull back to the extent possible), thick or poorly fitting eyeglass temples, pencils or caps will lessen the protection.

- Earmuffs must be regularly inspected for cracks or worn parts and replaced as needed. Typical life for foam cushion sealing rings is 12 months.
- Clean the exterior of the hearing protector regularly with soap and warm water. Do not immerse the whole headset in water.
- Do not store the hearing protector behind a windshield or at temperatures above 131°F(55°C).
- Certain chemical substances may damage this product. Contact the manufacturer for more information.
- The product is suitable for transport in original packaging.
- The earmuffs passes small, medium and large size ranges, compliant to EN 352-1:2020.

## 6. CAUTION

If instructions are not followed, bodily injury may result or protection may be severely These hearing protectors help reduce exposure to hazardous noise and other loud sounds. Misuse or failure to wear hearing protectors at all times when you are exposed to noise may result in hearing loss or injury.

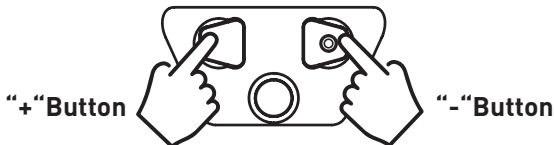
If there is any drainage from your ear or if you have an ear infection, consult with your physician before wearing hearing protection. Failure to do so may result in hearing loss or injury.

For proper use, see user instructions or contact EARMOR® customer service Email: [cs@earmor.com](mailto:cs@earmor.com)

## 7. TO REDUCE THE SAFETY RISK WHEN USING THE PRODUCT

- Only use the specified type of battery provided by OPSMEN.
- If the headset is not to be used for a long time, please remove the batteries to prevent leakage that may damage the headset or cause personal injury.
- If the microphone or any accessory is damaged or malfunctioning, please cease usage immediately.
- Contact OPSMEN official after-sales mailbox [cs@earmor.com](mailto:cs@earmor.com) for maintenance service.

## 8. OPERATING INSTRUCTIONS



### Changing And Replacing The Batteries (Fig 1)

- 1-2. Ensure the polarity of the batteries aligns with the indicators inside the battery compartment, then proceed to insert the batteries (2xAAA).
  - 3-4. Open the battery compartment lid, press the electrode tab with your finger, and by tilting the headset, the batteries can be easily removed.
- \* The lids must be pressed all the way down to ensure good seal. Low battery level is indicated by voice message "low battery", repeatedly.

## Turn On And Off The Headphones (Fig 2)

Press and hold the [+] or [-] button for 3 seconds until the “power on” audio prompt is heard. If the “power off” audio prompt is heard, the device has been powered off.

The headset will emit a warning sound: “auto shut off after 3 minute” after 3 hours and 57 minutes of inactivity. This is a warning that the headset will automatically power off after four hours of inactivity.

## The Volume Can Be Adjusted In Five Levels. (Fig 3)

The device has 5 pickup volume levels. Level 5 is max and level 1 is mute. Level 3 is default after reset or re-pairing.

Press [+] to increase volume. “Dudu” prompt means max volume reached.

Press [-] to decrease volume. “Ambient Listening off” prompt means device muted.

## Entering the Menu (Fig 4)

1. Press and hold the [+] and [-] buttons to enter the menu. A voice will confirm.
2. Press the [-] button briefly to toggle through the menu. The menu steps are listed below.
3. Use the [+] button to change the setting and, if applicable, toggle through the available settings. A voice message confirms each step, followed by the current setting. Changes are also confirmed by a voice message. After a few seconds of no activity, the menu re turns to volume mode. By pressing [+] and [-], the volume setting can be instantly reached at any stage of the menu.

## Entering ear-plug mode (Fig 5, Fig 6)

Fig5: Double-click [+] to enter earplug mode.

Fig6: Click on the [+] or [-] to directly exit the earplug mode.

\*No audio prompts in Bluetooth® mode. Device reverts to normal mode when powered off.

## PTT wire connection(Fig 7)

To connect, firmly insert the connector into the receptacle located on the bottom of the left earcup until you feel/hear a click.

Your hearing and enhance situational awareness and communication in noisy environments. With advanced and multifunctional features, it is suitable for a variety of missions. The voice menu allows you to select the functions you need with ease. Additionally, the U174 download cables can be removed to connect to a NATO standard PTT for command and communication.

## EN 352 SAFETY INFORMATION:

- The output of the level-dependent circuit of the hearing protector may exceed the external sound level.
- Installing the sanitary cover on the cushion may affect the acoustic performance of the earmuffs.
- Performance will decrease with battery consumption. The expected continuous use time of the battery is approximately 50 hours.
- Maybe adversely affected by certain chemical substances. More information can be get from the manufacturer.



This product contains electrical and electronic components and must not be disposed of using standard garbage collection. Please consult your local electrical and electronic equipment disposal instructions.

## TO REDUCE THE RISKS ASSOCIATED WITH HARMFUL NOISE

- Listening to music or audio communication may reduce situational awareness and the ability to hear warning signals. Stay alert and adjust the volume to the lowest acceptable level.
- Use and maintain the hearing protector properly. Check the hearing protector before each use. If it is damaged, please choose an undamaged hearing protector or avoid a noisy environment.
- Do not bend or reshape the headband, and ensure that there is enough clamping force to fix the earmuffs.
- Earmuffs must be regularly inspected for cracks and leaks to be worn properly, replaced as needed.
- The output of the electronic audio circuit of this hearing protector may exceed the daily limit sound level. Please adjust the audio volume to the lowest acceptable level

## BLUETOOTH® OPERATION

### 1. Connect to Bluetooth®

- A. Turn ON / OFF Bluetooth® mode:  
Press and hold the button for 2 seconds.

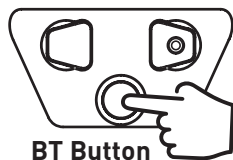
Prompt tone: BT mode / Ambient listening Mode

- B. Bluetooth® pairing:  
Establish a Bluetooth® connection between the device and the earphones. The device automatically reconnects when Bluetooth® is turned on.  
\*Reconnect failure: The earphones enter Bluetooth® mode, but the device cannot automatically reconnect. After 10 seconds, pairing will start automatically.

Prompt tone: Connected

- C. Force pairing mode:  
Press and hold the " button" for 5's

Automatic shutdown of Bluetooth® mode: If not connected to a device for 5 minutes.



### 2. Play Music/Answer A Call

To listen to music or make a call, the Bluetooth® device must first be registered (paired).

Setting	Operation
Play music	Click the "BT button".
Pause music	Click the "BT button".
Answer a call	Click the "BT button".
Reject a call	Press and hold for 2's
Hang up a call	Click the "BT button".



## FCC WARNING

This device complies with part 15 of the FCC Rules. Operation is subject to the following two conditions: (1) this device may not cause harmful interference, and (2) this device must accept any interference received, including interference that may cause undesired operation. Any changes or modifications not expressly approved by the party responsible for compliance could void the user's authority to operate the equipment.

NOTE: This equipment has been tested and found to comply with the limits for a Class B digital device, pursuant to Part 15 of the FCC Rules. These limits are designed to provide reasonable protection against harmful interference in a residential installation. This equipment generates, uses and can radiate radio frequency energy and, if not installed and used in accordance with the instructions, may cause harmful interference to radio communications. However, there is no guarantee that interference will not occur in a particular installation.

If this equipment does cause harmful interference to radio or television reception, which can be determined by turning the equipment off and on, the user is encouraged to try to correct the interference by one or more of the following measures:

- Reorient or relocate the receiving antenna.
- Increase the separation between the equipment and receiver.
- Connect the equipment into an outlet on a circuit different from that to which the receiver is connected.
- Consult the dealer or an experienced radio/TV technician for help. The device has been evaluated to meet general RF exposure statement.

The device can be used in portable exposure condition without restriction

FCC ID:2A4IK-M33

## SPECIFICATIONS:

Life time:	50 hours
Battery capacity:	2AAA
Talk time (1kHz, 50% volume):	50 Hours
Operating temperature:	-40°C~65°C
Storage temperature (full set):	-50°C~70°C
Net weight:	320±10
Net weight with microphone:	335±10

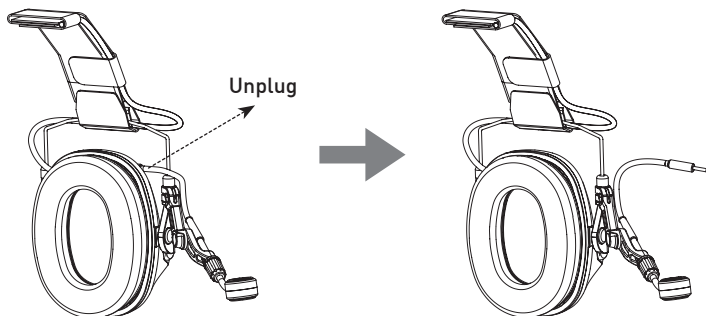
## AUDIO INPUT LEVEL

The audio level in the hearing protector is dependent on the audio input level. To prevent harmful noise levels, the hearing protector audio levels is limited to 82dB when connected to a Personal Music Player (PMP). If the hearing protector is connected to a PMP or other device with very high output level, it is the user's responsibility to set the audio input level to a safe level.

# M33 Milpro Headset adapter Installation Guide

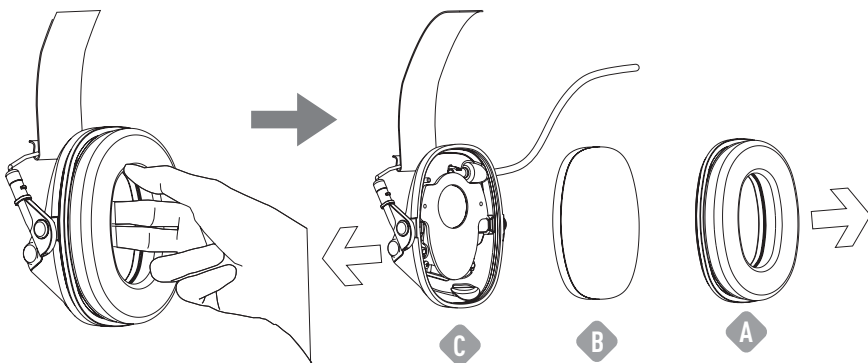
## STEP.1.

1. As shown in Figure 1, unplug the microphone.

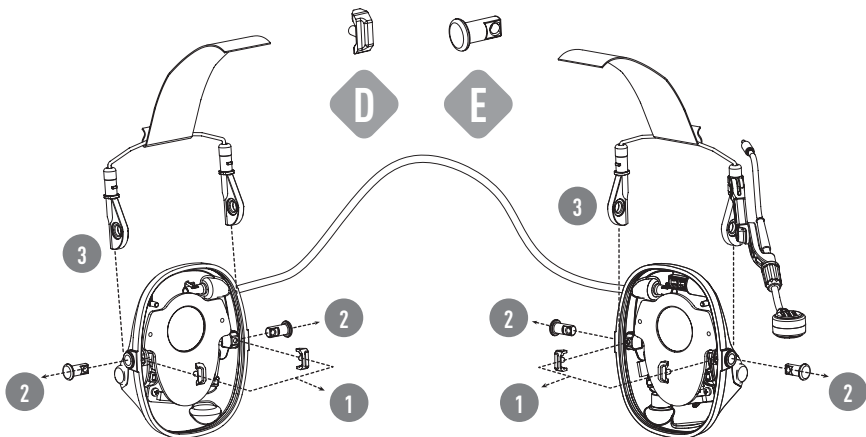


2. Select either side of the earmuff to disassemble (the right side is demonstrated in the image). As shown in Figure 1, place your finger into the space between the earmuff ring (Part A) and the cotton pad (Part B), and exert force in the direction of the arrow to detach the earmuff (Part C) from the earmuff ring.

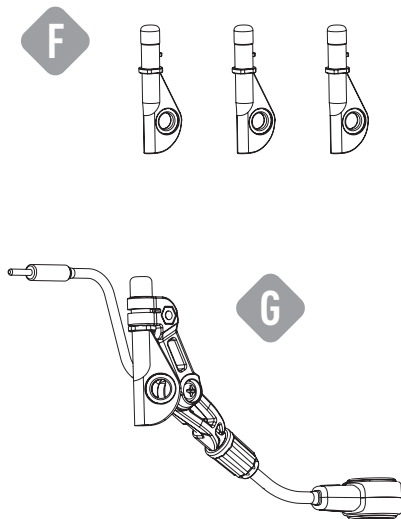
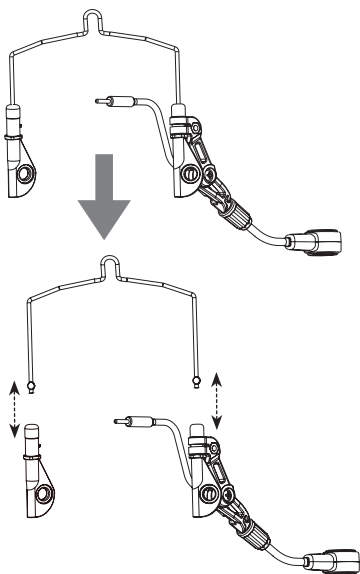
\*During the entire replacement process, please wear gloves to avoid accidental cuts from some sharp components.



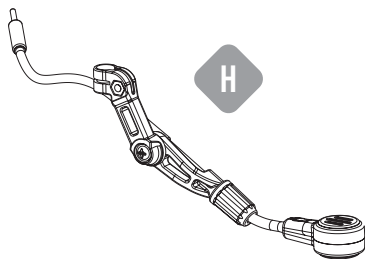
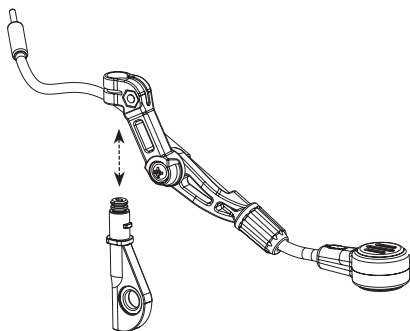
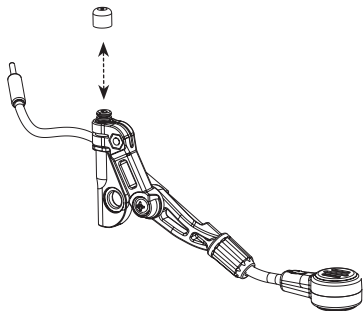
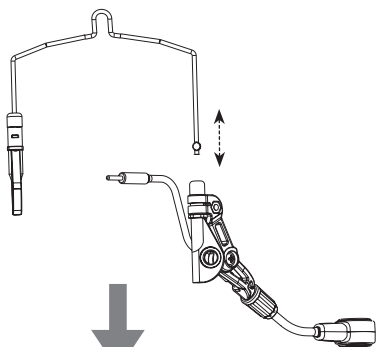
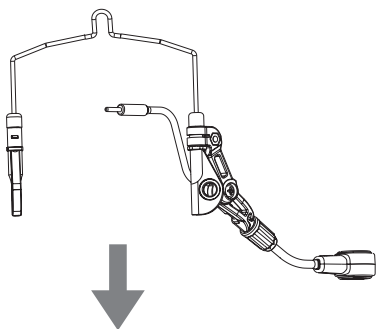
3. As shown in the picture, gently remove the single positioning buckle (Part D) in Part C in the direction of the arrow, and place it in a safe location to avoid loss. In step 2, continue to remove the bracket pivot (Part E) in the direction of the arrow, and place it in a safe location to avoid loss.



- 4.1. When switching from the standard M33 adapter to the M11 adapter, follow these steps to disassemble the microphone: Firstly, remove the caps on both sides of the adapter and disconnect the microphone plug. Then, manually rotate the left microphone adapter (component G) to balance, separate the bracket, and place it in a safe location.



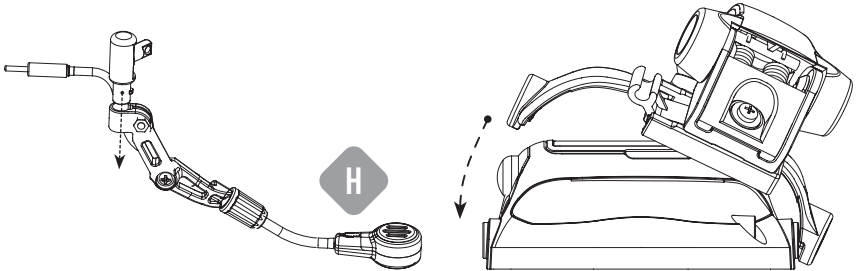
4.2. To switch from the standard M33 adapter to the M18 adapter, follow these steps for microphone disassembly: First, rotate the left microphone bracket to the balance position, allowing it to separate from the headphone bracket. Next, rotate the cap at the top of the headphone bracket to disconnect the arm. Finally, place the microphone parts in a secure location.



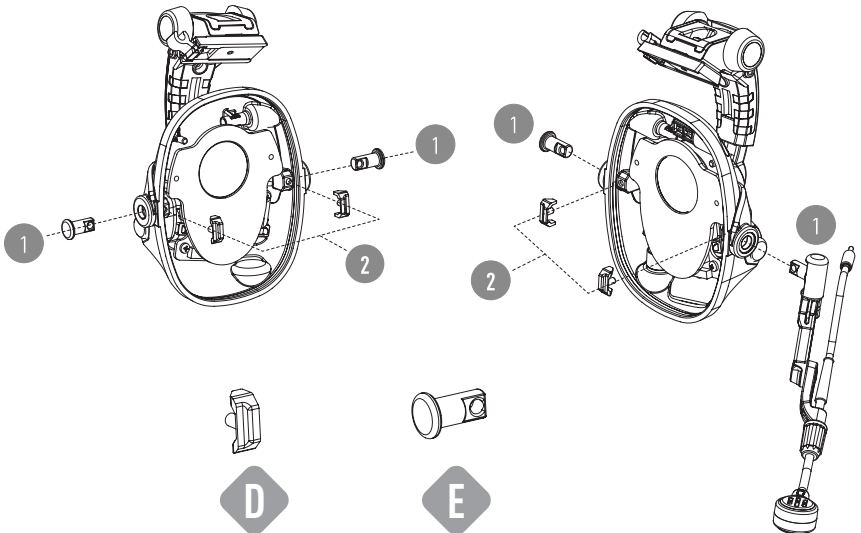
## STEP.2. Assembly

### M33 Milpro Headset M18 Adapter Installation Guide

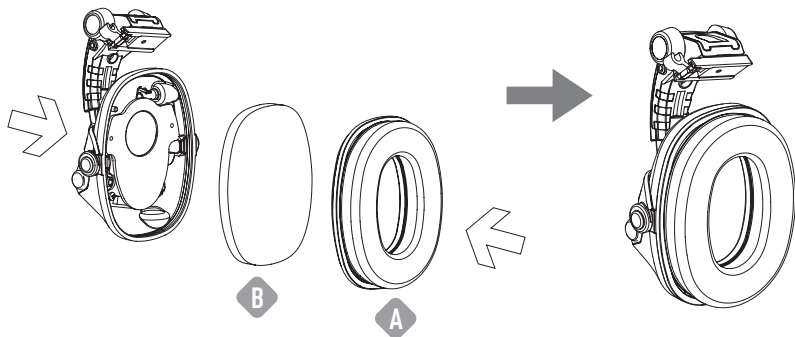
1. Firstly, rotate the adapter leg at the microphone end of the headband adapter to its limit and remove it. Unscrew the cap of the adapter leg, then rotate the microphone arm to its limit and remove it. Next, align the separate tenon part from the M18 adapter package with the microphone arm limit, and rotate it to the extreme position. Extract the two M18 helmet adapters from the accessories, align the adapter slot with the earmuff slot in the direction shown in Figure 6, and gently push the adapter into the slot.



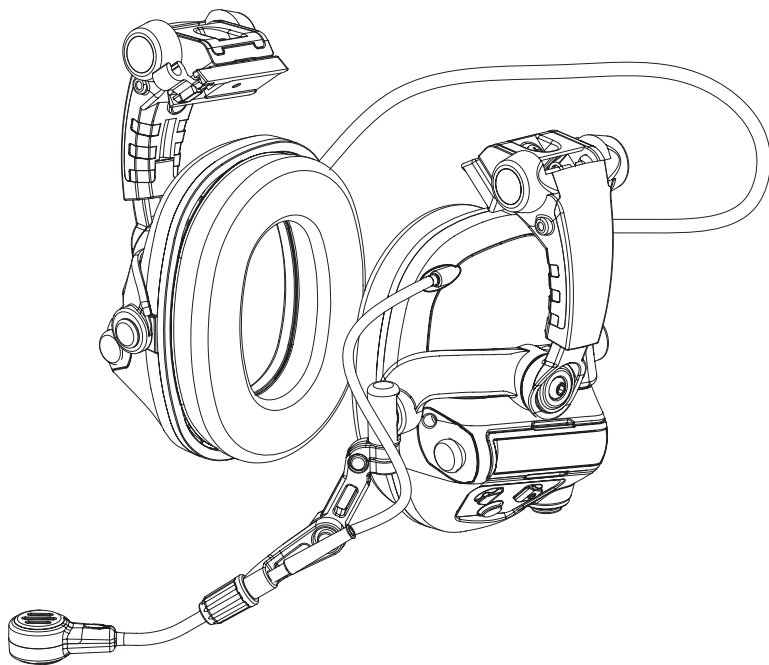
2. Insert the adapter pivot (Part E) respectively, and install the positioning buckle (Part D). Also, please pay attention to the wire position connecting the earmuffs on both sides.
3. Install the microphone. Take component H, which was removed during disassembly, and install it onto the M18 adapter as shown in the figure.



4. Align the corresponding cotton pads (Part B) and earmuff rings (Part A) with the earmuffs, press and install until they fit closely to the earmuffs.

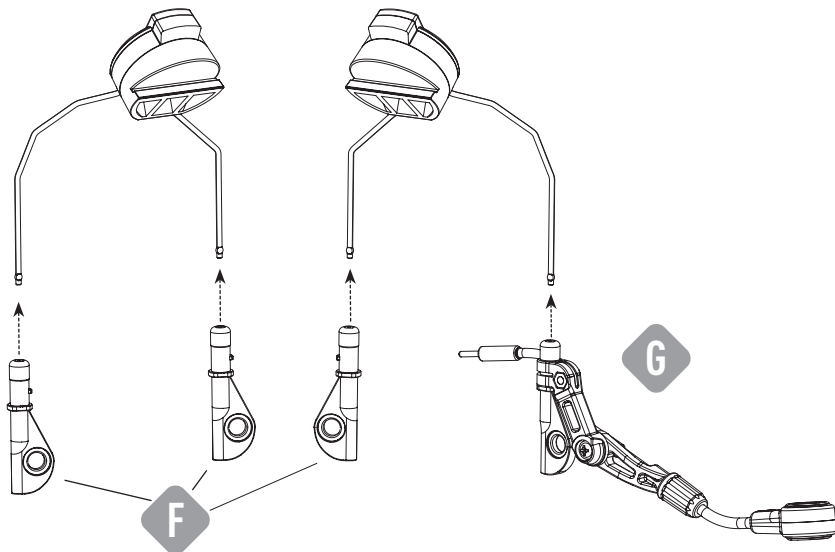


5. Replacement complete.

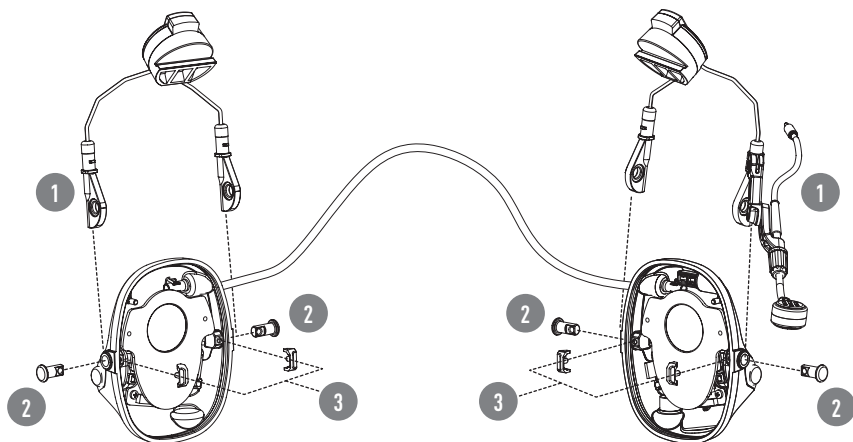


# M33 Milpro Headset M11 Bracket Replacement and Adaptor Installation Guide

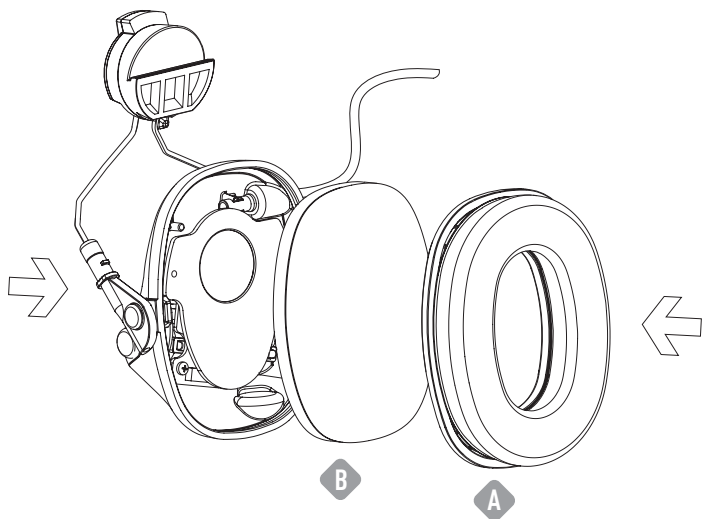
1. Remove two M11 helmet adapters from the included accessories. Following the direction indicated in the picture, insert each adapter into the adapter axle.



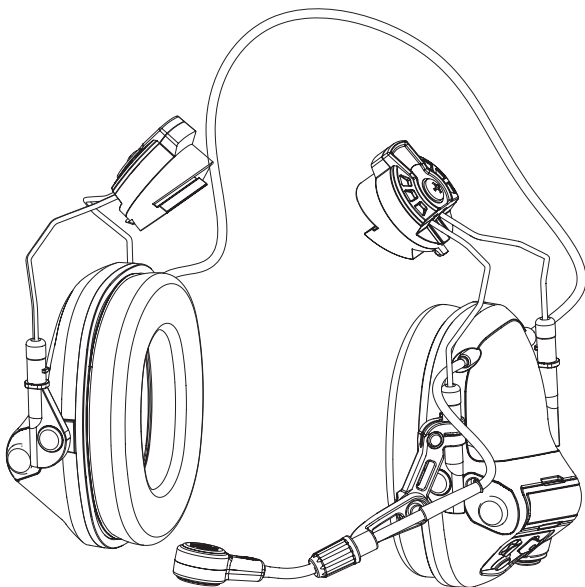
2. Continue with the installation of the positioning buckle. At the same time, pay attention to the location of the electrical wires connecting the two ear muffs.



3. Align the corresponding cotton pads (Part B) and earmuff rings (Part A) with the earmuffs, press and install until they fit closely to the earmuffs.



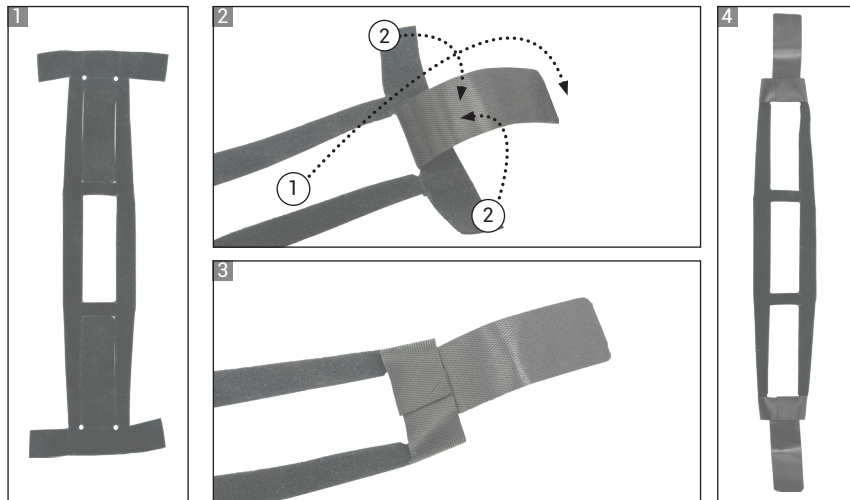
4. Replacement complete.



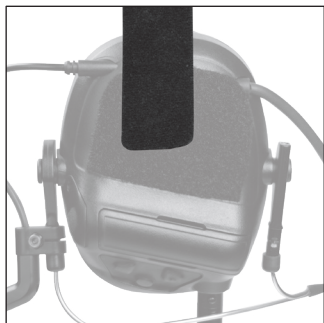


# M33 N Series Assembly And Replacement Guide

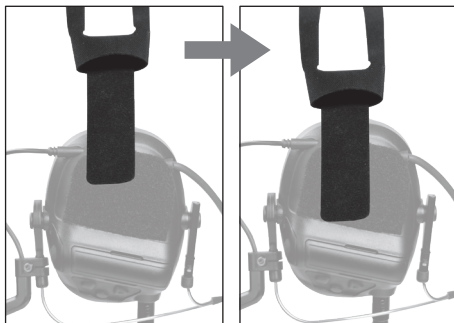
1. Adjust both ends of the load-bearing strap as shown in the figure;



2. Fix both ends of the load-bearing strap on the hook-and-loop fastener of the headphone shell as shown in the figure; (Note: It must not cover the pickup microphone)



3. As shown in the figure, please adjust the length of both ends of the load-bearing strap for comfort when wearing;



4. As shown in the figure, please note that the communication wire should be placed on the inner side of the bracket when connecting the PTT.



\*The N series is equipped with a rear-neck style bracket and a lightweight adjustable load-bearing strap. It can adapt to various head accessories or protective gear. For different usage styles, please refer to the following instructions:

5. When used with a duckbill cap or similar cap, please wear the cap securely first, and then wear the assembled M series headphones.  
(Note: The headphones need to be worn with the load-bearing strap above the cap)



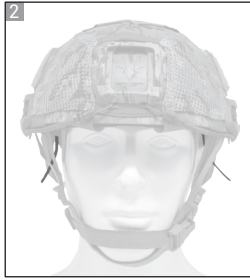
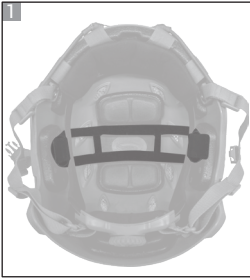
## M33N Series Assembly and Replacement

When used with a helmet without accessory slots, please follow the steps below:

Separate the load-bearing strap from the headphones and place it on the inner side of the helmet as shown in Figure 1;

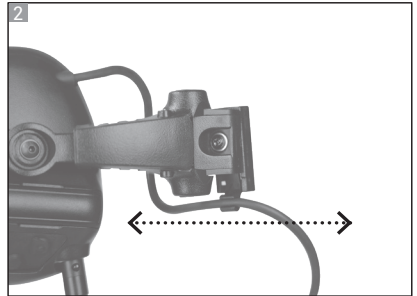
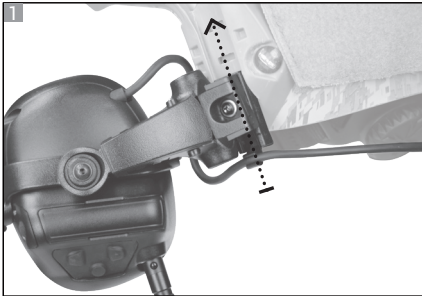
Wear the helmet (as shown in Figure 2, expose both ends of the load-bearing strap);

Wear the headphones, fix the headphones on the head and then fix both sides of the Velcro part with the headphones (as shown in Figure 3).

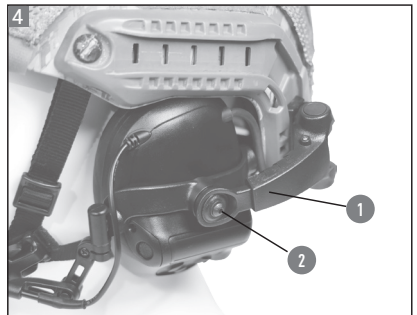
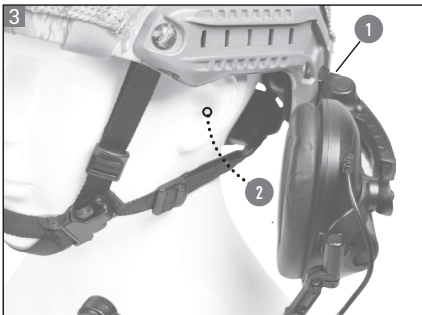


## M18 Adapter Wearing Instructions:

1. Distinguish between the left and right sides of the headphones, and install the bracket base (with the wire slot facing down) on the ARC rear rail, respectively. You can adjust the base to a suitable position using the rail buckle.
2. Simultaneously adjust the headphone connection wires in the wire slots on both sides to make the headphone connection wires fit closely to the helmet.



3. Open the closed joint [1], rotate the headphones to the ear position, and then close the headphones inward.
4. Adjust the length of the bracket [1] to a suitable position and coordinate with the universal axis to ensure the headphones fully fit the head.



## WARRANTY

EARMOR® M33 Milpro Headset is warranted to be free of defects in material and workmanship for a period of 1 year from the date of original purchase.

The warranty is nullified in all of the following situations:

1. The product(s) is/are broken down, reconstructed and/or modified by unauthorized parties.
2. The product(s) is/are damaged through improper use.
3. The product(s) is/are damaged by leakage of batteries.

## CE COMPLIANCE STATEMENT:

We, EARMOR®, declare under our sole responsibility that the EARMOR® Headset complies with the essential requirements and provisions of the applicable European Union (EU) Directives and harmonized standards.

The product has been tested and approved in accordance with

EN 352-1:2020, EN 352-4:2020, EN 352-6:2020, EN 352-8:2020.

Unwearing Instructions:



1. Open the closed joint.
2. Rotate the headphones to the back of the helmet.
3. Close the headphones inward so that they fit closely to the helmet.

## CONTACT

For the latest information on EARMOR® products and services

Please contact a local distributor or email: [info@earmor.com](mailto:info@earmor.com) / [cs@earmor.com](mailto:cs@earmor.com)

EARMOR® official website <http://earmor.com/> shall prevail in case of any product data changes.

	Mandatory conformity marking. CE mark below by Notified Body Number, The various components of the CE marking must have the same vertical dimension, and may not be smaller than 5 mm.
M33	Model Name/Number.
EN 352	EN 352, Hearing protectors - General requirements
	Manufacturer's logo
02/2023	date of manufacture



**ANSI**  
S3.19-1974

**OPSMEN® Tech Co., Ltd.**

Tel: +86 20 81179170

Fax: +86 20 81179171

E-mail: [info@earmor.com](mailto:info@earmor.com) / [cs@earmor.com](mailto:cs@earmor.com)

Add: Room 601, Building A, No.94 Liwan Road, Liwan District, Guangzhou, Guangdong Province, China

