

RB8762-35A1

Bluetooth Module

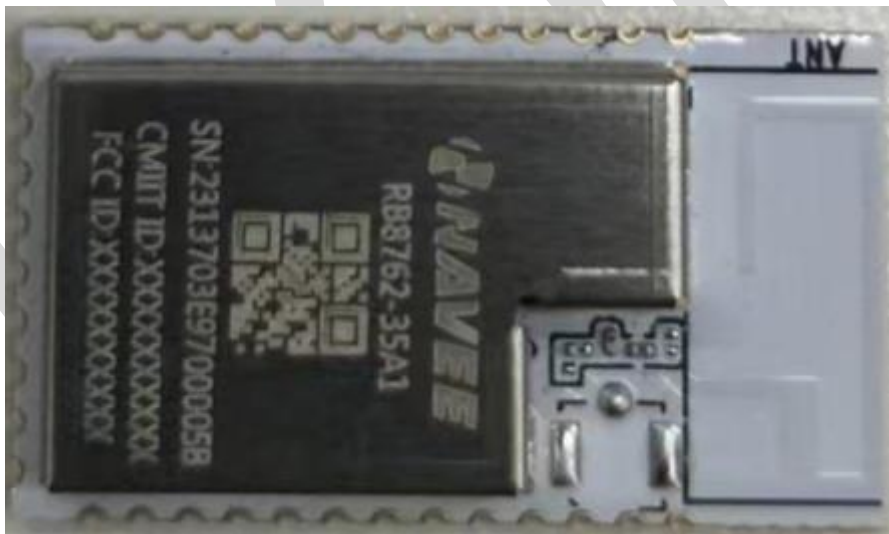

DISCLAIMER AND COPYRIGHT NOTICE

Information in this document, including URL references, is subject to change without notice.

This document is provided "As if" with no whatsoever, including any warranty of merchantability, noninfringement, fitness for any purpose, or any warranty otherwise arising out of any proposal, specification or samples.

All liability, including liability for infringement of any proprietary rights, relating to use of information in this document is disclaimed. No licenses express or implied, by estoppel or otherwise, to any intellectual property rights are granted herein.

The Bluetooth logo and symbol belong to the Bluetooth SIG Inc.

The Wi-Fi Alliance Member Logo is a trademark of the Wi-Fi Alliance.

All trade names, trademarks and registered trademarks mentioned in this document are property of their respective owners, and are hereby acknowledged.

Copyright ITON Technology Corp. All rights reserved.

Table of Contents

Table of Contents.....	2
1. Device Overview.....	3
1.1 Features.....	3
1.2 Applications.....	3
1.3 Descriptions.....	3
1.4 Functional Block Diagram.....	4
2. Pin Configuration and Functions.....	4
2.1 Module Pin Diagram.....	4
2.2 Pin Functions.....	5
3. Specifications.....	8
3.1 Absolute Maximum Rating.....	8
3.2 Power Consumption.....	9
3.3 RF Characteristics.....	9
4. Application, Implementation, and Layout.....	11
4.1 Application Diagram.....	11
4.2 Typical Application Circuit.....	12
4.3 Layout Guideline.....	13
5. Mechanical and Package.....	13
5.1 Mechanical Dimension.....	13
5.2 Recommended PCB Footprint.....	13
5.3 Package Information.....	14
6. Thermal Reflow.....	14
7. Ordering Information.....	15
8. Revision History.....	15

1. Device Overview

1.1 Features

- Ultra-low consumption with intelligent PMU
- Supports Bluetooth 5.0 core specification
- Supports 2Mbps LE
- LE advertising extensions
- LE long range
- Additional Adv channel
- High duty cycle non-connectable Adv
- Supports multiple level low energy states
- Supports LE L2CAP connection oriented channel support
- Supports GAP, ATT/GATT, SMP, L2CAP
- Supports LE low duty directed advertising
- Supports LE data length extension feature
- Supports OTA programming mechanism for firmware upgrade

1.2 Applications

- Mesh LED
- Mice and wireless keyboards
- Game controllers & joysticks
- Voice remote controls
- Home automation
- Sensor network devices
- Amazon gadgets
- Intelligent Lighting

1.3 Descriptions

The RB8762-35A1 Bluetooth module is designed base on the Realtek RTL8762CMF that is an ultra-low power system on-chip solution for Bluetooth 5.0 low energy applications. It combines the excellent performance of a leading RF transceiver with a low-power ARM Cortex-M4F and rich powerful supporting features and peripherals. The embedded ARM Cortex-M4F 32-bit CPU features a 16-bit instruction set with 32-bit extensions (Thumb-2® technology) that delivers high-density code with a small memory footprint. By

using a single-cycle 32-bit multiplier, a 3-stage pipeline, and a Nested Vector Interrupt Controller (NVIC), the ARMCortex-M4F makes program execution simple and highly efficient.

The RB8762-35A1 module consists of three major parts: PCB antenna, 40MHz crystal and RTL8762CMF BLE chip. All of the module materials can withstand an ultimate ambient temperature of 105°C which makes the module very suitable for lamps or other occasions with high temperature requirements.

1.4 Functional Block Diagram

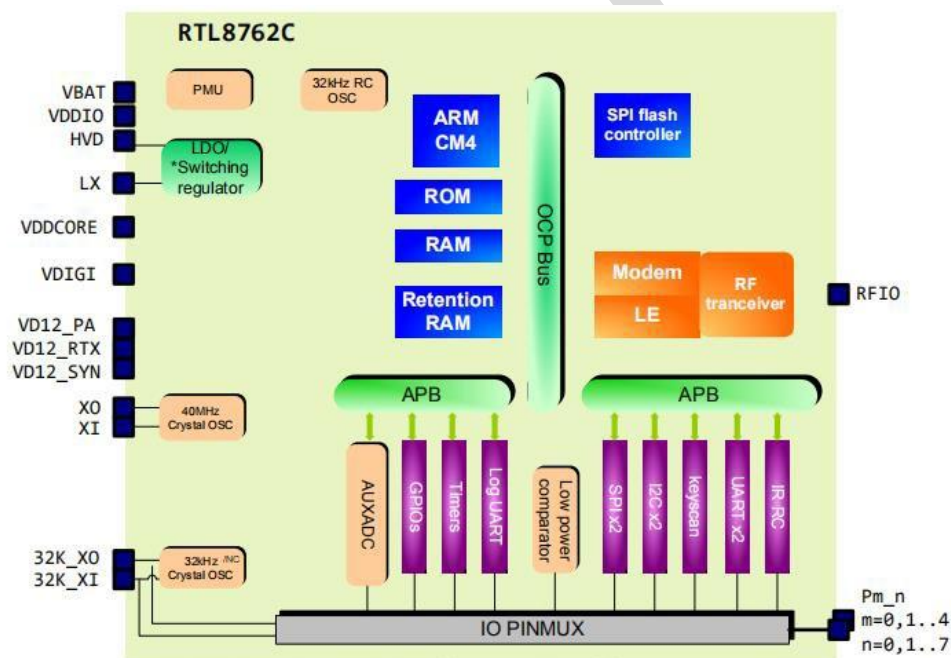

Note: Switching regulator is only in RTL8762CMF

Figure 1. Block Diagram of RTL8762CMF

2. Pin Configuration and Functions

2.1 Module Pin Diagram

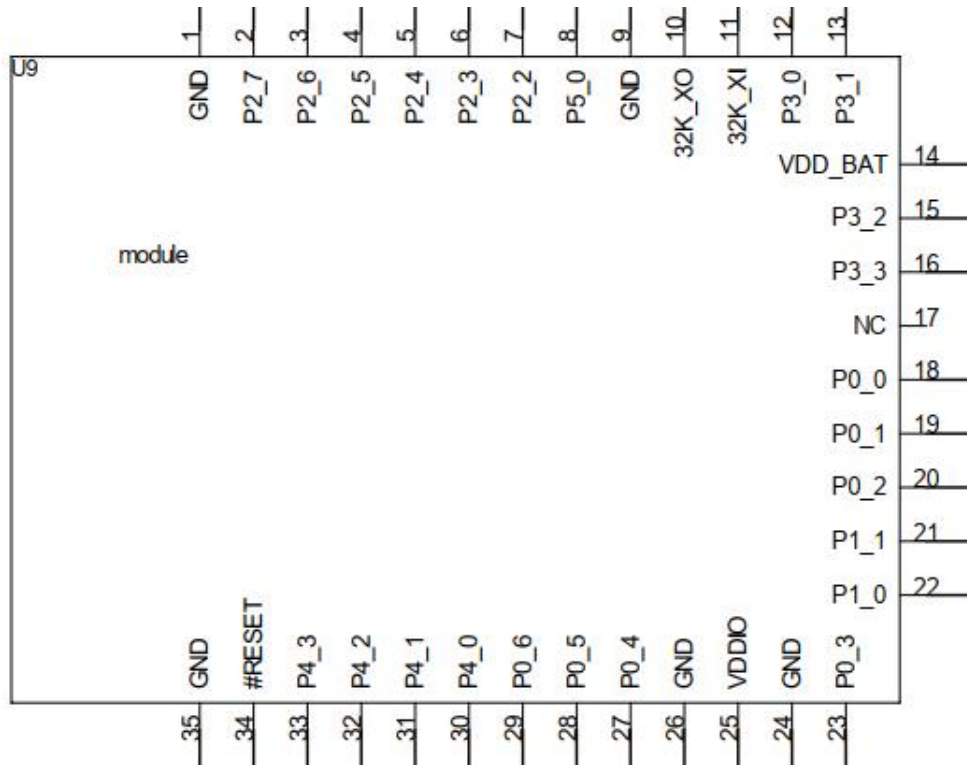

Figure 2. Pin Diagram of RB8762-35A1

2.2 Pin Functions

Pin	Name	Hardware Default Pull setting(100K)Reset state	Description
1	GND	Ground	Ground
2	P2_7	Pull Down	General purpose IO; refer to the Pin Multiplexer Table 8mA driving capability With wakeup function With inter strong/weak pull-up and pull-down AUXADC input 7

3	P2_6	Pull Down	General purpose IO; refer to the Pin Multiplexer Table 8mA driving capability With wakeup function With inter strong/weak pull-up and pull-down AUXADC input 6
4	P2_5	Pull Down	General purpose IO; refer to the Pin Multiplexer Table 8mA driving capability With wakeup function With inter strong/weak pull-up and pull-down AUXADC input 5
5	P2_4	Pull Down	General purpose IO; refer to the Pin Multiplexer Table 8mA driving capability With wakeup function With inter strong/weak pull-up and pull-down AUXADC input 4
6	P2_3	Pull Down	General purpose IO; refer to the Pin Multiplexer Table 8mA driving capability With wakeup function With inter strong/weak pull-up and pull-down AUXADC input 3
7	P2_2/SDA	Pull Down	General purpose IO; refer to the Pin Multiplexer Table 8mA driving capability With wakeup function With inter strong/weak pull-up and pull-down AUXADC input 2; When a built-in gravity sensor is installed, external pins cannot be connected;
8	P5_0/SCK	Pull Down	General purpose IO; refer to the Pin Multiplexer Table 8mA driving capability With wakeup function With inter strong/weak pull-up and pull-down; When a built-in gravity sensor is installed, external pins cannot be connected;
9	GND	Ground	Ground
10	32K_XO	32K_XO	40M crystal oscillator out
11	32K_XI/INT1	32K_XI/INT1	32K crystal oscillator IN(NC)/ Gravity sensor interrupt pin ; When a built-in gravity sensor is installed, external pins cannot be connected;
12	P3_0	Pull Up	General purpose IO; refer to the Pin Multiplexer Table 8mA driving capability With wakeup function With inter strong/weak pull-up and pull-down HCI_UART_TX(default)
13	P3_1	Pull Up	General purpose IO; refer to the Pin Multiplexer Table 8mA driving capability With wakeup function With inter strong/weak pull-up and pull-down HCI_UART_RX(default)
14	VDD_BAT	power	Supply 1.8V~3.3V
15	P3_2	Pull Up	General purpose IO; refer to the Pin Multiplexer Table 8mA driving capability With wakeup function With inter strong/weak pull-up and pull-down

16	P3_3	Pull Up	General purpose IO; refer to the Pin Multiplexer Table 8mA driving capability With wakeup function With inter strong/weak pull-up and pull-down
17	NC	NC	NC
18	P0_0	Pull Down	General purpose IO; refer to the Pin Multiplexer Table 8mA driving capability With wakeup function With inter strong/weak pull-up and pull-down
19	P0_1	Pull Down	General purpose IO; refer to the Pin Multiplexer Table 8mA driving capability With wakeup function With inter strong/weak pull-up and pull-down
20	P0_2/INT2	Pull Down	General purpose IO; refer to the Pin Multiplexer Table 8mA driving capability With wakeup function With inter strong/weak pull-up and pull-down Gravity sensor interrupt pin When a built-in gravity sensor is installed, external pins cannot be connected;
21	P1_1	Pull Up	General purpose IO; refer to the Pin Multiplexer Table 8mA driving capability With wakeup function With inter strong/weak pull-up and pull-down SWDCLK(default)
22	P1_0	Pull Up	General purpose IO; refer to the Pin Multiplexer Table 8mA driving capability With wakeup function With inter strong/weak pull-up and pull-down SWDIO(default)
23	P0_3	Pull Up	LOG_UART_TX Power on trap: Pull-up for normal operation Pull-down to bypass executing program code in flash
24	GND	Ground	Ground
25	VDDIO	Power	Supply 1.8V~3.3V power for digital IO PADs VDDIO should be less than or equal to VDD_BAT
26	GND	Ground	<ul style="list-style-type: none"> • GPIO: P12 • Keyboard scan output (column): KSO4 • A/D converter input 23
27	P0_4	Pull Down	General purpose IO; refer to the Pin Multiplexer Table 8mA driving capability With wakeup function With inter strong/weak pull-up and pull-down
28	P0_5	Pull Down	General purpose IO; refer to the Pin Multiplexer Table 8mA driving capability With wakeup function With inter strong/weak pull-up and pull-down
29	P0_6	Pull Down	General purpose IO; refer to the Pin Multiplexer Table 8mA driving capability With wakeup function With inter strong/weak pull-up and pull-down
30	P4_0	Pull Down	General purpose IO; refer to the Pin Multiplexer Table 8mA driving capability With wakeup function With inter strong/weak pull-up and pull-down

31	P4_1	Pull Down	General purpose IO; refer to the Pin Multiplexer Table 8mA driving capability With wakeup function With inter strong/weak pull-up and pull-down
32	P4_2	Pull Down	General purpose IO; refer to the Pin Multiplexer Table 8mA driving capability With wakeup function With inter strong/weak pull-up and pull-down
33	P4_3	Pull Up	General purpose IO; refer to the Pin Multiplexer Table 8mA driving capability With wakeup function With inter strong/weak pull-up and pull-down
34	RESET		Hardware reset pin, low active
35	GND	Ground	Ground

Note: Pin Multiplexer

All GPIO pins are configurable via the built-in pin multiplexer(PINMUX), The table shows all GPIO pin configurations.All pins have an internal pull-up pull-down resistor for controlling GPIO_PU and GPIO_PD.

Pin Multiplexer Table

0	IDEL	25	qdec_phase_a_z	50	SPI0_CLK (master only)	75	KEY_COL_17	100	Reserved	125	Reserved
1	HCI_UART_TX	26	qdec_phase_b_z	51	SPI0_MO (master only)	76	KEY_COL_18	101	Reserved	126	Reserved
2	HCI_UART_RX	27	UART2_TX	52	SPI0_MI (master only)	77	KEY_COL_19	102	PDM (clk)	127	MCLK
3	HCI_UART_CTS	28	UART2_RX	53	SPI2W_DATA (master only)	78	KEY_ROW_0	103	PDM (data)		
4	HCI_UART_RTS	29	UART1_TX	54	SPI2W_CLK (master only)	79	KEY_ROW_1	104	UART2_CTS		
5	I2C0_CLK	30	UART1_RX	55	SPI2W_CS (master only)	80	KEY_ROW_2	105	UART2_RTS		
6	I2C0_DAT	31	UART1_CTS	56	SWD_CLK	81	KEY_ROW_3	106	Reserved		
7	I2C1_CLK	32	UART1_RTS	57	SWD_DIO	82	KEY_ROW_4	107	Reserved		
8	I2C1_DAT	33	IRDA_TX	58	KEY_COL_0	83	KEY_ROW_5	108	Reserved		
9	PWM2_P	34	IRDA_RX	59	KEY_COL_1	84	KEY_ROW_6	109	Reserved		
10	PWM2_N	35	UART0_TX	60	KEY_COL_2	85	KEY_ROW_7	110	Reserved		
11	PWM3_P	36	UART0_RX	61	KEY_COL_3	86	KEY_ROW_8	111	Reserved		
12	PWM3_N	37	UART0_CTS	62	KEY_COL_4	87	KEY_ROW_9	112	Reserved		
13	PWM0	38	UART0_RTS	63	KEY_COL_5	88	KEY_ROW_10	113	Reserved		
14	PWM1	39	SPH_SS_N_0 (master only)	64	KEY_COL_6	89	KEY_ROW_11	114	Reserved		
15	PWM2	40	SPH_SS_N_1 (master only)	65	KEY_COL_7	90	DWGPI0	115	Reserved		
16	PWM3	41	SPH_SS_N_2 (master only)	66	KEY_COL_8	91	I2S_LRCLK	116	Reserved		
17	PWM4	42	SPI1_CLK (master only)	67	KEY_COL_9	92	I2S_BCLK	117	EN_EXPA		
18	PWM5	43	SPH_MO (master only)	68	KEY_COL_10	93	I2S_ADCDAT	118	EN_EXLNA		
19	PWM6	44	SPH_MI (master only)	69	KEY_COL_11	94	I2S_DACDAT	119	ANT_SW0		
20	PWM7	45	SPI0_SS_N_0 (slave)	70	KEY_COL_12	95	Reserved	120	ANT_SW1		
21	qdec_phase_a_x	46	SPI0_CLK (slave)	71	KEY_COL_13	96	DMIC1_CLK	121	ANT_SW2		
22	qdec_phase_b_x	47	SPI0_SO (slave)	72	KEY_COL_14	97	DMIC1_DAT	122	ANT_SW3		
23	qdec_phase_a_y	48	SPI0_SI (slave)	73	KEY_COL_15	98	Reserved	123	Reserved		
24	qdec_phase_b_y	49	SPI0_SS_N_0 (master only)	74	KEY_COL_16	99	Reserved	124	Reserved		

3. Specifications

3.1 Absolute Maximum Rating

1) Power supply voltage:

VDDIO: 1.8V~3.3V

VDD_BAT:1.8V~3.3V

Note: VDDIO should be less than or equal to VDD_BAT.

- 2) Operation temperature range: -30°C~+105°C
- 3) Storage temperature range: -40°C~+125°C

3.2 Power Consumption

Condition: VDD_BAT=3V, VDDIO=3V, Ambient Temperature: 25°C

1) Low Power Mode

Power Mode	Always on Registers	32k RCOSC/XTAL	Retention SRAM	CPU	Wakeup Method	Current Consumption(Typical)
Power down	ON	OFF	OFF	OFF	Wakeup by GPIO	450nA
Deep LPS	ON	ON	Retention	OFF	Wakeup by timer	2.5uA(with 160K SRAM in retention state)

2) Active Mode

Condition: VDD_BAT=3V, VDDIO=3V, Ambient Temperature: 25°C

Power Mode	Current Consumption(Typical)
Active RX mode	7.3mA
Active TX mode(TX power:0dBm)	7.9mA
Active TX mode(TX power:4dBm)	9.6mA
Active TX mode(TX power:7.5dBm)	11.3mA

3.3 RF Characteristics

1) Receiver RF Specifications

Parameter	Condition	Min.	Typ.	Max.
Frequency Range(MHz)		2402		2480
Sensitivity(dBm)	PER≤30.8%	-94		
Maximum Input Level(dBm)	PER≤30.8%		-1	
C/I	C/Ico-channel(dB)	21		
	C/I+1MHz(dB)	15		
	C/I-1MHz(dB)	15		
	C/I+2MHz(dB)	-17		
	C/I-2MHz(dB)	-15		
	C/I+3MHz(dB)	-27		
	C/Iimage(dB)	-9		
	C/Iimage+1MHz(dB)	-15		
	C/Iimage-1MHz(dB)	-15		
Blocker Power(dBm)	30~2000MHz,	-30		

	Wanted signal level=-67dBm			
	2003~2399MHz, Wanted signal level=-67dBm	-35		
	2484~2997MHz, Wanted signal level=-67dBm	-35		
	3000MHz~12.75GHz, Wanted signal level=-67dBm	-30		
Max PER Report Integrity	Wanted signal:-30dBm		50%	
Max Intermodulation level (dBm)	Wanted signal(f ₀):-64dBm Worst intermodulation level@2f ₁ -f ₂ =f ₀ , f ₁ -f ₂ =nMHz, n=3,4,5...	-50		

Note1: Do not include spur channel;

Note2: Depend on PCB design and registers setting.

2) Transmitter RF Specifications

Parameter	Condition	Min.	Typ.	Max.
Maximum Output Power (dBm)	Conducted	-	-	8
Adjacent Channel Power Ratio (dBm)	+2MHz	-	-	-20
	-2MHz	-	-	-20
	≥+3MHz	-	-	-30
	≤-3MHz	-	-	-30
Modulation Characteristics	Δf _{1avg} (kHz)	-	250	-
	Δf _{2max} (kHz)	185	-	-
	Δf _{2max}	-	100	-
	Δf _{2max} PassRate(%)	-	0.88	-
Carrier Frequency Offset and Drift	Average F _n (kHz)	-	12.5	-
	Drift Rate(kHz/50us)	-	10	-
	Avg Rate(kHz/50us)	-	10	-
	Max Rate(kHz/50us)	-	10	-
Output power of second harmonic(dBm)	-	-	-50 (note)	-
Output power of third harmonic(dBm)	-	-	-50 (note)	-

Note: Tested by EVB with RF PI network.

4. Application, Implementation, and Layout

4.1 Application Diagram

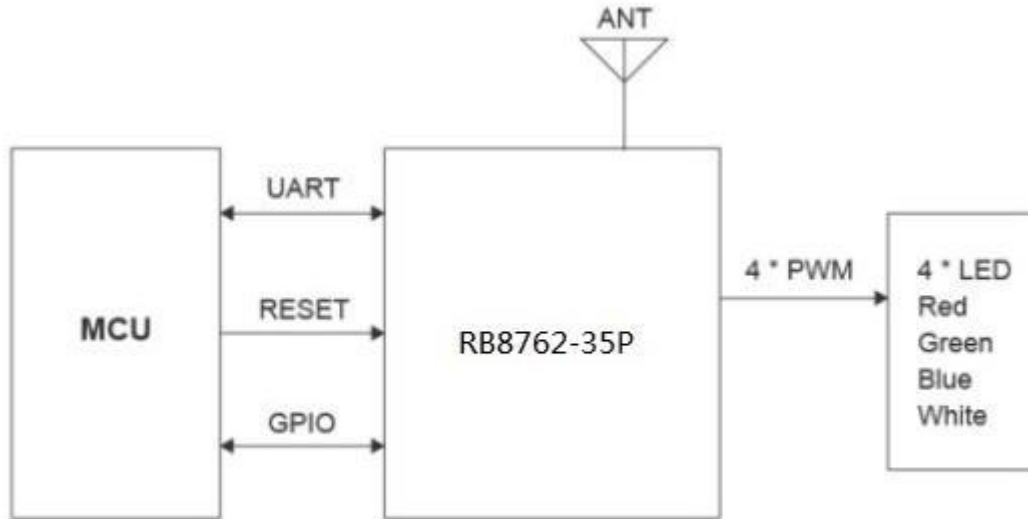

Figure 3. Remote Control Block Diagram of RB8762-35A1

4.2 Typical Application Circuit

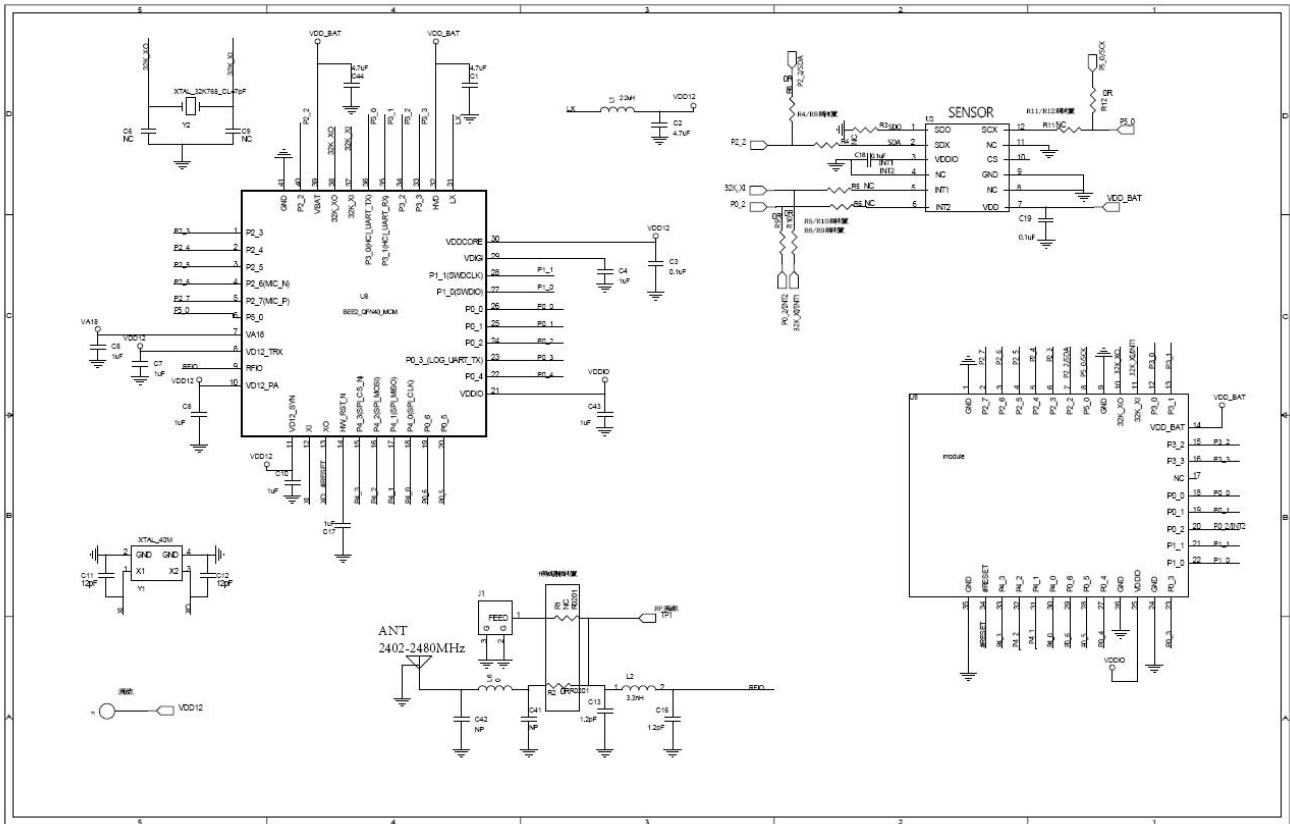

Figure 4. Mesh LED schematic of RB8762-35A1

4.3 Layout Guideline

1. Keep RF traces with 50 Ohm impedance.
2. The antenna needs to have enough clearance area.
3. The filter capacitor should be as close as possible to the module.
4. Do not place strong interference lines under the module.

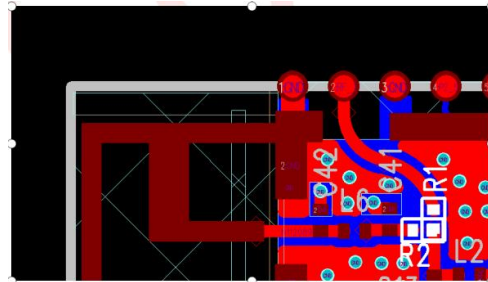

Figure 5. RF Interface Selection

5. Mechanical and Package

5.1 Mechanical Dimension

PCB thickness: 1.0mm. Module thickness: 3.4mm±0.25mm

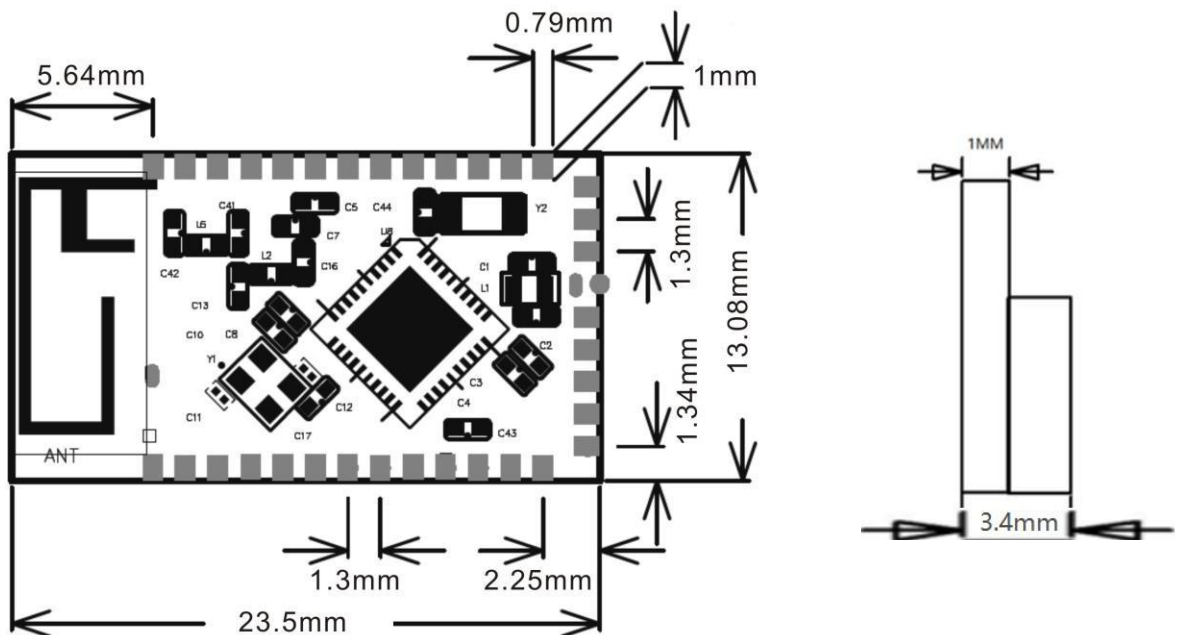

Figure 6. Mechanical Dimension of RB8762-35A1

Note: Unit is mm. Size tolerance:±0.13mm.

5.2 Recommended PCB Footprint

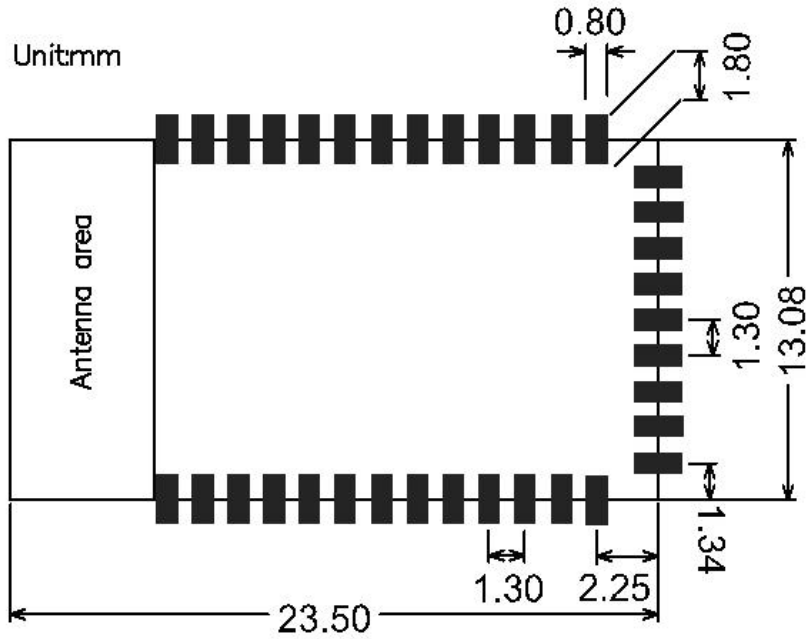

Figure 7. Recommended PCB Footprint of RB8762-35A1

5.3 Package Information

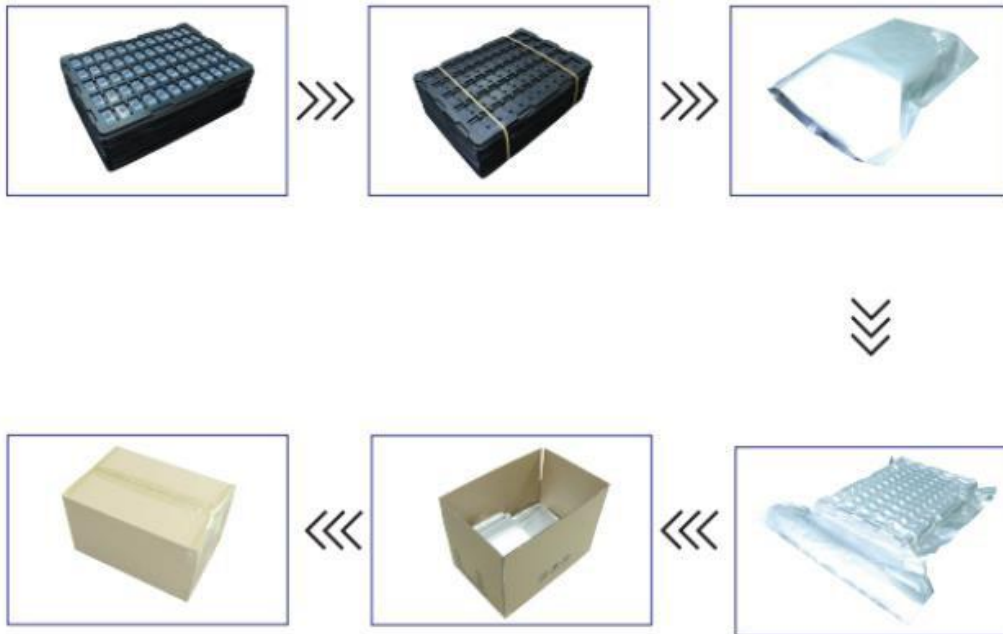

Figure 8. Brief Packaging Process of RB8762-35A1 Modules

6. Thermal Reflow

Referred to IPC/JEDEC standard.

Peak temperature: <250°C

Number of times: ≤ 2

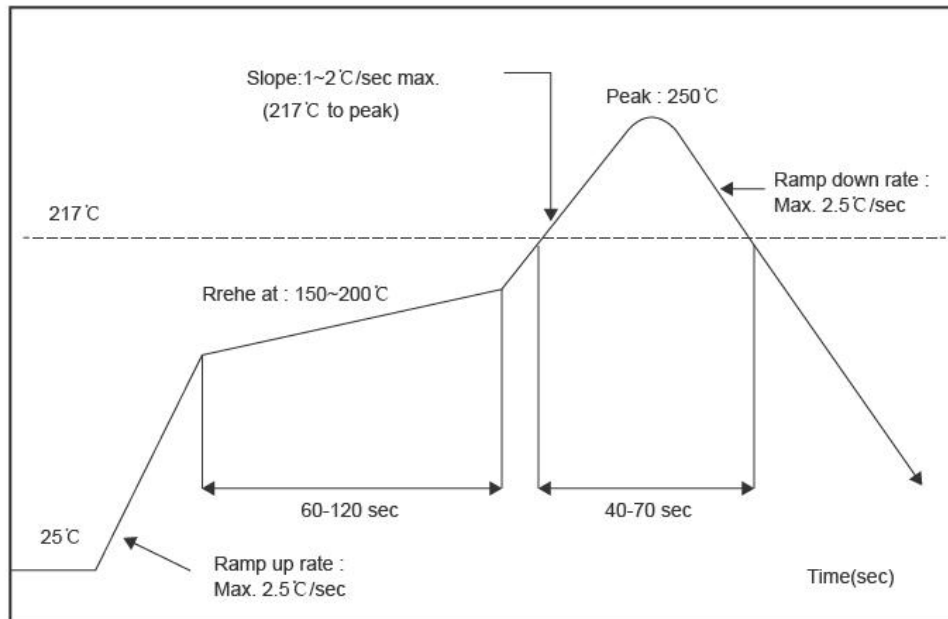

Figure 9. Recommended Reflow for Lead Free Solder

Note: The module is recommended not to go through reflow oven twice.

7. Ordering Information

Part NO.	Working Voltage	ANT	Shielding Cover	Remark
RB8762-35A1	VDDIO:1.8V~3.3V VDD_BAT:1.8V~3.3V	PCB ANT	Not Included	

8. Revision History

Version	Change Content	Reviser	Date
V0.1	Initial Version	Mql	2023.08.03

9.FCC STATEMENT

This device complies with Part 15 of the FCC Rules. Operation is subject to the following two conditions:
This device may not cause harmful interference, and
This device must accept any interference received, including interference that may cause undesired operation.

Warning: Changes or modifications not expressly approved by the party responsible for compliance could void the user's authority to operate the equipment.

Note: This equipment has been tested and found to comply with the limits for a Class B digital device, pursuant to part 15 of the FCC Rules. These limits are designed to provide reasonable protection against harmful interference in a residential installation. This equipment generates uses and can radiate radio frequency energy and, if not installed and used in accordance with the instructions, may cause harmful interference to radio communications. However, there is no guarantee that interference will not occur in a particular installation. If this equipment does cause harmful interference to radio or television reception, which can be determined by turning the equipment off and on, the user is encouraged to try to correct the interference by one or more of the following measures:

- Reorient or relocate the receiving antenna.
- Increase the separation between the equipment and receiver.
- Connect the equipment into an outlet on a circuit different from that to which the receiver is connected.
- Consult the dealer or an experienced radio/TV technician for help.

The device has been evaluated to meet general RF exposure requirement. The device can be used in portable exposure condition without restriction.

Integration instructions for host product manufacturers according to KDB 996369 D03 OEM Manual v01r01

2.2 List of applicable FCC rules

FCC Part 15 Subpart C 15.247

2.3 Specific operational use conditions

Operation Frequency	:	2402MHz to 2480MHz
Number of Channel	:	40
Modulation Type	:	GFSK
Antenna Type	:	PCB Antenna
Antenna Gain(Peak)	:	1.22 dBi

The module can be used for mobile or portable applications with a **maximum 1.22 dBi antenna**. The host manufacturer installing this module into their product must ensure that the final composite product complies with the FCC requirements by a technical assessment or evaluation to the FCC rules, including the transmitter operation. The host manufacturer has to be aware not to provide information to the end user regarding how to install or remove this RF module in the user's manual of the end product which integrates this module. The end user manual shall include all required regulatory information/warning as show in this manual.

2.4 Limited module procedures

Not applicable. The module is a Single module and complies with the requirement of FCC Part 15.212.

2.5 Trace antenna designs

Not applicable. The module has a fixed antenna.

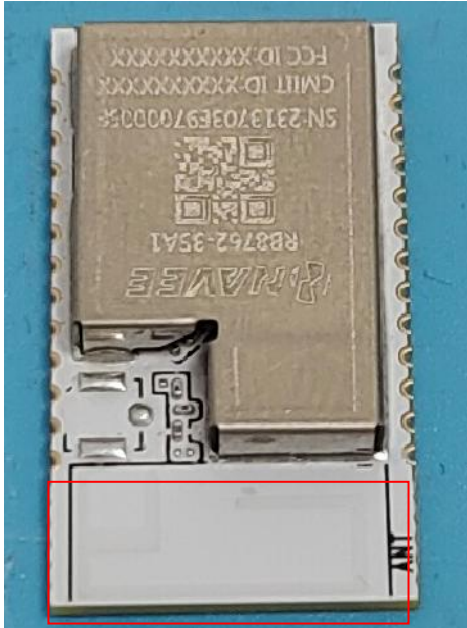

2.6 RF exposure considerations

The device can be used in portable exposure condition without restriction and if RF exposure statement or module layout is changed, then the host product manufacturer required to take responsibility of the module through a change in FCC ID or new application. The FCC ID of the module cannot be used on the final product. In these circumstances, the host manufacturer will be responsible for re-evaluating the end product (including the transmitter) and obtaining a separate FCC authorization.

2.7 Antennas

Antenna Specification are as follows:

Antenna Type: PCB antenna

Antenna Gain(Peak): 1.22 dBi (Provided by customer)

This device is intended only for host manufacturers under the following conditions: The transmitter module may not be co-located with any other transmitter or antenna;

The module shall be only used with the PCB antenna(s) that has been originally tested and certified with this module. The antenna must be either permanently attached or employ a 'unique' antenna couple.

As long as the conditions above are met, further transmitter test will not be required. However, the host manufacturer is still responsible for testing their end-product for any additional compliance requirements required with this module installed (for example, digital device emissions, PC peripheral requirements, etc.).

2.8 Label and compliance information

Host product manufacturers need to provide a physical or e-label stating "Contains FCC ID :2A4GZ-RB876235A1 With their finished product."

2.9 Information on test modes and additional testing requirements

Operation Frequency	:	2402MHz to 2480MHz
Number of Channel	:	40
Modulation Type	:	GFSK
Antenna Type	:	PCB Antenna
Antenna Gain(Peak)	:	1.22 dBi

Host manufacturer must perform test of radiated & conducted emission and spurious emission, etc according to the actual test modes for a stand-alone modular transmitter in a host, as well as for multiple simultaneously transmitting modules or other transmitters in a host product. Only when all the test results of test modes comply with FCC requirements, then the end product can be sold legally.

2.10 Additional testing, Part 15 Subpart B disclaimer

The modular transmitter is only FCC authorized for FCC Part 15 Subpart C 15.247 and that the host product manufacturer is responsible for compliance to any other FCC rules that apply to the host not covered by the modular transmitter grant of certification. If the grantee markets their product as being Part 15 Subpart B compliant (when it also contains unintentional-radiator digital circuitry), then the grantee shall provide a notice stating that the final host product still requires Part 15 Subpart B compliance testing with the modular transmitter installed.

2.11 Note EMI Considerations

Host manufacture is recommended to use D04 Module Integration Guide recommending as "best practice" RF design engineering testing and evaluation in case non-linear interactions generate additional non-compliant limits due to module placement to host components or properties.

2.12 How to make changes

This module is stand-alone modular. If the end product will involve the Multiple simultaneously transmitting condition or different operational conditions for a stand-alone modular transmitter in a host, host manufacturer have to consult with module manufacturer for the installation method in end system. According to the KDB 996369 D02 Q&A Q12, that a host manufacture only needs to do an evaluation (i.e., no C2PC required when no emission exceeds the limit of any individual device (including unintentional radiators) as a composite. The host manufacturer must fix any failure.

IC STATEMENT

English: "

This device complies with Industry Canada licence-exempt RSS standard(s). Operation is subject to the following two conditions:

this device may not cause interference, and

this device must accept any interference, including interference that may cause undesired operation of the device."

French: "

Le présent appareil est conforme aux CNR d'Industrie Canada applicables aux appareils radio exempts de licence. L'exploitation est autorisée aux deux conditions suivantes :

l'appareil ne doit pas produire de brouillage, et

l'utilisateur de l'appareil doit accepter tout brouillage radioélectrique subi, même si le brouillage est

susceptible d'en compromettre le fonctionnement."

L'appareil a été évalué pour répondre aux exigences générales d'exposition aux RF. L'appareil peut être utilisé sans restriction dans des conditions d'exposition portables.

RF warning statement:

The device has been evaluated to meet general RF exposure requirement. The device can be used in portable exposure condition without restriction.

These specific instructions will detail how to configure all of the control and operating parameters that are accessible by the host product for power control to ensure host compliance with the requirements of RSS-102:

Integration instructions for host product manufacturers according to RSS-102 — Radio Frequency (RF) Exposure Compliance of Radiocommunication Apparatus (All Frequency Bands)

2.2 List of applicable ISED rules

RSS-247 — Digital Transmission Systems (DTSs), Frequency Hopping Systems (FHSs) and Licence-Exempt Local Area Network (LE-LAN) Devices

2.3 Specific operational use conditions

Operation Frequency	:	2402MHz to 2480MHz
Number of Channel	:	40
Modulation Type	:	GFSK
Antenna Type	:	PCB Antenna
Antenna Gain(Peak)	:	1.22 dBi

The module can be used for mobile or portable applications with a **maximum 1.22 dBi antenna**. The host manufacturer installing this module into their product must ensure that the final composite product complies with the RSS-102 requirements by a technical assessment or evaluation to the RSS-102 rules, including the transmitter operation. The host manufacturer has to be aware not to provide information to the end user regarding how to install or remove this RF module in the user's manual of the end product which integrates this module. The end user manual shall include all required regulatory information/warning as show in this manual.

2.4 Limited module procedures

Not applicable. The module is a Single module and complies with the requirement of RSS-Gen — General Requirements for Compliance of Radio Apparatus

2.5 Trace antenna designs

Not applicable. The module has a fixed antenna.

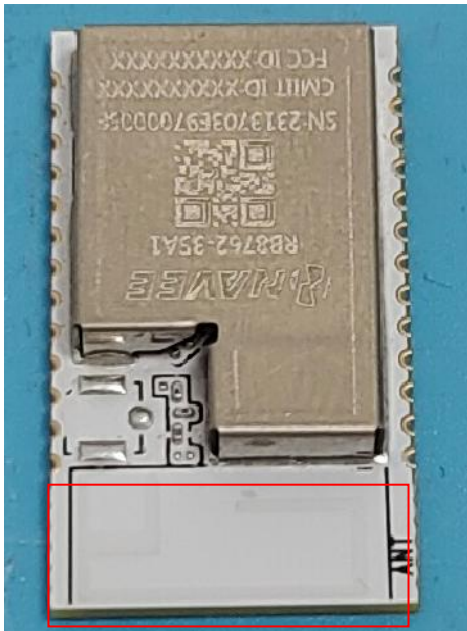

2.6 RF exposure considerations

The device can be used in portable exposure condition without restriction and if RF exposure statement or module layout is changed, then the host product manufacturer required to take responsibility of the module through a change in IC ID or new application. The IC ID of the module cannot be used on the final product. In these circumstances, the host manufacturer will be responsible for re-evaluating the end product (including the transmitter) and obtaining a separate ISED authorization.

2.7 Antennas

Antenna Specification are as follows:

Antenna Type:PCB antenna

Antenna Gain(Peak):1.22 dBi (Provided by customer)

This device is intended only for host manufacturers under the following conditions: The transmitter module may not be co-located with any other transmitter or antenna;

The module shall be only used with the PCB antenna(s) that has been originally tested and certified with this module. The antenna must be either permanently attached or employ a 'unique' antenna couple.

As long as the conditions above are met, further transmitter test will not be required. However, the host manufacturer is still responsible for testing their end-product for any additional compliance requirements required with this module installed (for example, digital device emissions, PC peripheral requirements, etc.).

2.8 Label and compliance information

Host product manufacturers need to provide a physical or e-label stating "Contains IC ID :28570-RB876235A1 With their finished product.

2.9 Information on test modes and additional testing requirements

Operation Frequency	:	2402MHz to 2480MHz
Number of Channel	:	40
Modulation Type	:	GFSK

Antenna Type	:	PCB Antenna
Antenna Gain(Peak)	:	1.22 dBi

Host manufacturer must perform test of radiated & conducted emission and spurious emission, etc according to the actual test modes for a stand-alone modular transmitter in a host, as well as for multiple simultaneously transmitting modules or other transmitters in a host product. Only when all the test results of test modes comply with ISED requirements, then the end product can be sold legally.

2.10 Additional testing, Canada license-exempt RSS standard portion

Modular transmitters are ISED authorized for part RSS-247 only, and Host product manufacturers are responsible for complying with any other ISED rules applicable to the host product. The main unit does not fall within the scope of certification granted for modular transmitters. If grantees market their product, the product complies with the Industry Canada license-exempt RSS standard portion (when it also contains unintentional radiator digital circuitry), then the grantee should provide notification that the final host product still requires the modular transmitter host installed for additional compliance sex test.

2.11 Note EMI Considerations

Host manufacture is recommended to use RSS-102 Module Integration Guide recommending as "best practice" RF design engineering testing and evaluation in case non-linear interactions generate additional non-compliant limits due to module placement to host components or properties.

2.12 How to make changes

This module is stand-alone modular. If the end product will involve the Multiple simultaneously transmitting condition or different operational conditions for a stand-alone modular transmitter in a host, host manufacturer have to consult with module manufacturer for the installation method in end system. According to the RSS-102 that a host manufacture only needs to do an evaluation (i.e., no C2PC required when no emission exceeds the limit of any individual device (including unintentional radiators) as a composite. The host manufacturer must fix any failure.