

# INSTALLATION INSTRUCTIONS

## LTHR006SMXX-3PK

**PLEASE READ CAREFULLY BEFORE INSTALLING FIXTURE**  
Save these instructions, as you may need them at a later date.

Thank you for purchasing CloudyBay Smart LED Lighting Fixtures.



### HIGH WATTAGE SMART LED TRACK HEAD



**GENERAL:** All electrical connections must be in accordance with local and National Electrical Code (N.E.C.) standards. If you are unfamiliar with proper electrical wiring connections, contact and obtain the services of a qualified electrician. Use UL or IEC approved wire only for input/output connections.

Remove fixture and mounting components from the box, and make sure that no parts are missing, by referencing the illustration in the illustration instructions.

Turn power off before installation, inspection, or removal.  
Use all necessary precautions while performing this procedure.

Consult a qualified electrician to ensure correct branch circuit conductor. Min 90°C supply conductors.

Properly ground electrical enclosure. IT IS IMPERATIVE THAT THE OUTLET BOX BE PROPERLY GROUNDED.

DO NOT REVERSE THE HOT AND NEUTRAL CONNECTIONS, OTHERWISE SAFETY WILL BE COMPROMISED.

This Integrated LED Fixture has no lamp/bulb to replace.



Contact us through: [smart@cloudybaylighting.com](mailto:smart@cloudybaylighting.com)

#### PRODUCT CARE After Sales Service

1. Please discontinue to use product right away if product shows any visible defect and contact customer service.

2. If there is any problem with our lights for non-human reasons, please contact customer service, we will send you brand new replacement without need to returning goods or full refund.

3. If you are not completely satisfied with product after installation but prefer not to disassemble, contact with us right away, we will provide comparable compensations.

### 3-Year Limited Warranty

**LIMITED WARRANTY:** This fixture is warranted to be free from defects in workmanship and material for up to 3-years. Based upon reasonable household usage, when used in accordance with package and included instructions. If this fixture does not last for the time period guaranteed, manufacture will send you a replacement fixture upon receipt of the returned fixture, register receipt, and proof of purchase. To contact us, please email us at [smart@cloudybaylighting.com](mailto:smart@cloudybaylighting.com) to find out how to return the fixture. We are committed to making high quality products. Returning the fixture will help us monitor and further improve product quality. This replacement is the sole remedy available, and LIABILITY FOR INCIDENTAL OR CONSEQUENTIAL DAMAGES IS HEREBY EXPRESSLY EXCLUDED .

Figure 1

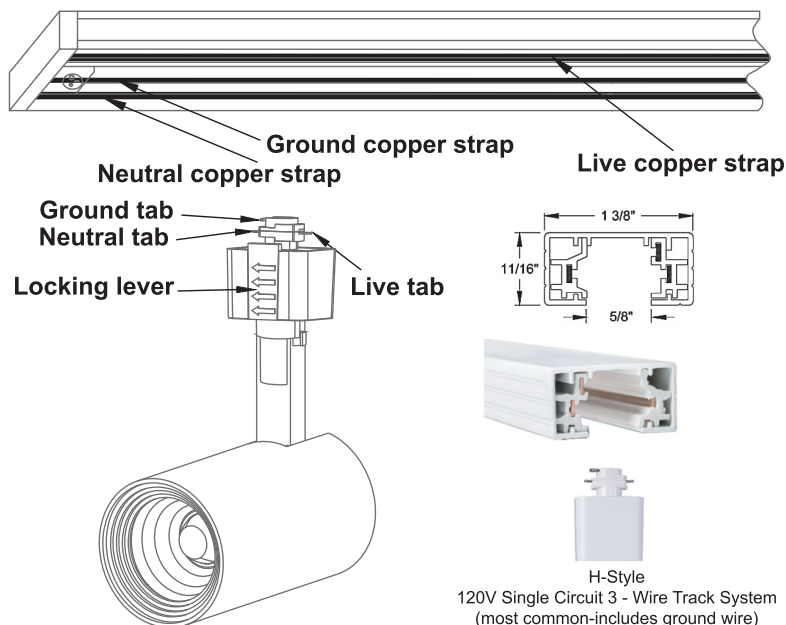

↓ Please follow these steps for installation. ↓

#### INSTALLATION INSTRUCTION-TRACK

1. Place track over outlet box and mark position of track mounting holes on ceiling or wall. On wallboard or plaster, drill "5/8" mounting holes.
2. Plain underside of track faces ceiling or wall and slotted side of track faces out to accept lights.
3. Install track to ceiling or wall using toggle bolts (furnished). On wood surfaces use standard #10 wood screws (not furnished).

#### INSTALLATION INSTRUCTIONS-LAMPHOLDER

CAUTION-Turn off switch at main power source before installing any track or fitting.

1. Pull down the locking lever and insert "Adaptor contact" into the slot in the track.
2. Rotate adaptor 1/4 turn 90° to locked position. NOTE: Polarity line of lampholder (Grounding tab, polarity side of two fingers) must point to track debossed polarity line so that the debossed polarity line of the track can be aligned with the polarity line (side) of adaptor.
3. To remove, depress the locking lever and turn 90°.

⚠: If you only have a dimmer at hand, set it to highest level only. If light performance is not good, we strongly advise you to change it to a regular switch.

#### FCC Statement

This equipment has been tested and found to comply with the limits for a Class B digital device, pursuant to part 15 of the FCC Rules. These limits are designed to provide reasonable protection against harmful interference in a residential installation. This equipment generates, uses and can radiate radio frequency energy and, if not installed and used in accordance with the instructions, may cause harmful interference to radio communications. However, there is no guarantee that interference will not occur in a particular installation. If this equipment does cause harmful interference to radio or television reception, which can be determined by turning the equipment off and on, the user is encouraged to try to correct the interference by one or more of the following measures:

- Reorient or relocate the receiving antenna.
- Increase the separation between the equipment and receiver.
- Connect the equipment into an outlet on a circuit different from that to which the receiver is connected.
- Consult the dealer or an experienced radio/TV technician for help.

Caution: Any changes or modifications to this device not explicitly approved by manufacturer could void your authority to operate this equipment.

This device complies with part 15 of the FCC Rules. Operation is subject to the following two conditions: (1) This device may not cause harmful interference, and (2) this device must accept any interference received, including interference that may cause undesired operation.

#### RF Exposure Information

This equipment complies with FCC radiation exposure limits set forth for an uncontrolled environment. This equipment should be installed and operated with minimum distance 20cm between the radiator and your body.



# INSTALLATION INSTRUCTIONS

## LTHR006SMXX-3PK

**PLEASE READ CAREFULLY BEFORE INSTALLING FIXTURE**  
Save these instructions, as you may need them at a later date.

Figure 2

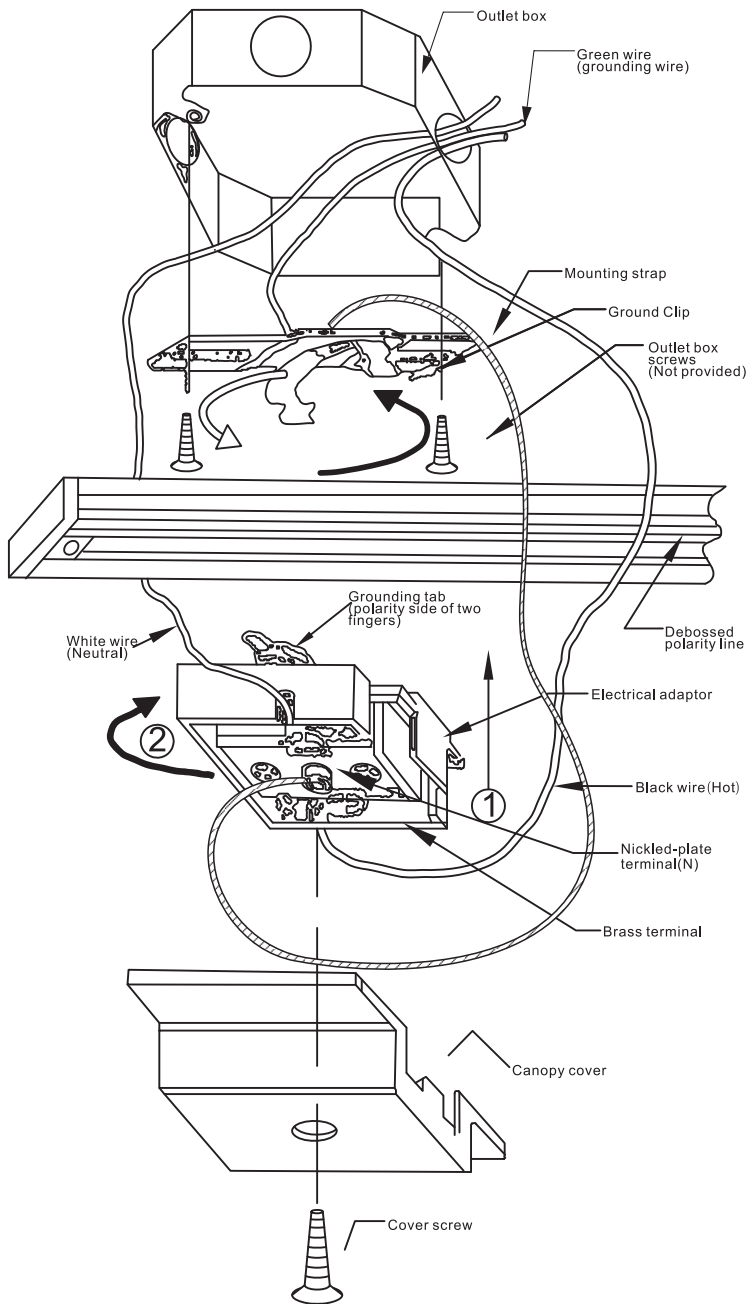

↓ *Please follow these steps for installation.* ↓

### INSTALLATION INSTRUCTIONS – FLOATING CANOPY

CAUTION – Turn off switch at main power source before installation any track or fitting.

1. Fasten mounting strap to outlet box. Connect ground wire.
2. Locate track below outlet box in desired position then:
  - a) Rotate ground clip to accept track and push track into clip.
  - b) Fasten track to ceiling following instructions supplied with the track section.
  - c) Track ends must be terminated with either a dead end or a connector.
3. Insert electrical adaptor into track, rotate 90° to locked position to make electrical contact. NOTE:
  - a) Polarity side of electrical adaptor (The side of grounding tab or marked "N" ) must point to track debossed polarity line.
  - b) Center line of electrical adaptor must be set on center line of outlet box.
4. Pull positive (Black) wire from outlet box and attach to brass screw terminal marked "P". Pull neutral (White) wire on opposite of track, and attach to nickled-plated screw terminal marked "N". Push excess wire back into outlet box-wire must hug track side. Install cover and secure with screw.