

东振电子有限公司

天线规格承认书

Antenna Specification for Approval

客户名称

Customer Name: _____

产品名称: _

Product Name: 2.4G 天线 全长33白色

客户型号:

Product Name: _____

产品料号:

Part NO.: 19芯*0.12*1.4PVC

制表:

Write By: 周敏

日期:

Issued Date: 2019-3-8

客 户:

工程R&D Dept	采购Business Dept	承认 Approved By

东 振 电 子

研发R&D Dept	工程 Engineer Dept	审核 Approval

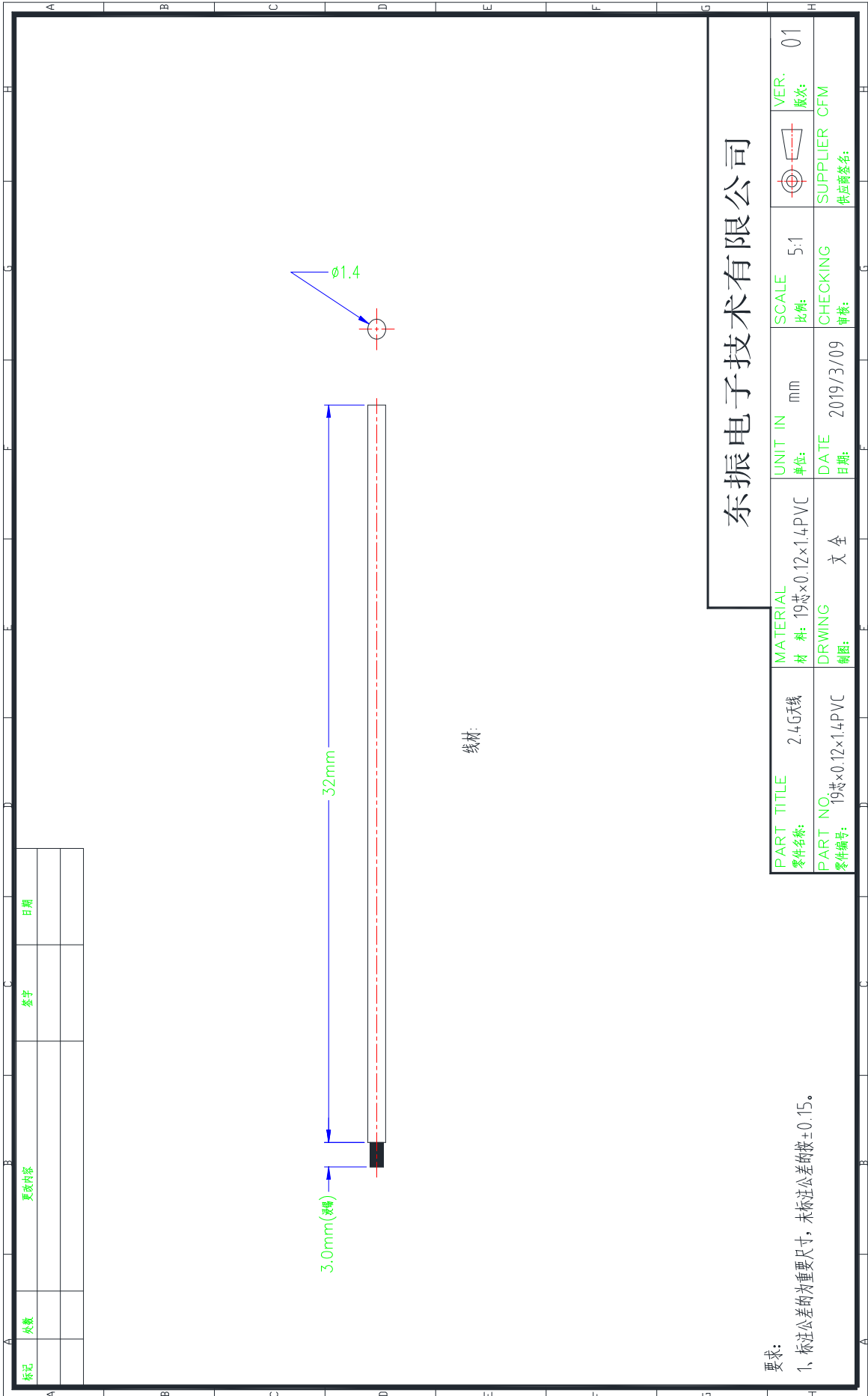

线材

东振电子有限公司

标记	次数	更改内容	签字	日期

PART TITLE 零件名称:	2.4G天线	MATERIAL 材料:	19芯×0.12×1.4PVC	UNIT IN 单位:	mm	SCALE 比例:	5:1	VER. 版本:	01
PART NO. 零件编号:	19芯×0.12×1.4PVC	DRAWING 制图:	文全	DATE 日期:	2019/3/09	CHECKING 审核:		SUPPLIER CFM 供应商签名:	

要求:

- 1、标注公差的重要尺寸，未标注公差的按±0.15。

Product Specification

A. Electrical Characteristics

Frequency 2400MHz ~2500MHz

VSWR <1.0

Efficiency >20%

Impedance 50 Ohm

Polarization Line

Gain 0.17DBi

B. Material & Mechanical Characteristics

Material of Radiator Cu

Cable Type 1.4 白色

Connector Type : NO

Dimension

C. Environmental

Operation Temperature - 30 °C ~ + 80 °C

Storage Temperature - 30 °C ~ + 85 °C

Test Equipment & Conditions

1. Network Analyzers :

Agilent 8753D 5071B

2. Communications Test Set:

Agilent E5515C

3. 3D Chamber Test System

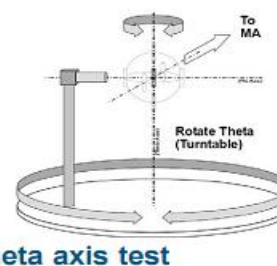
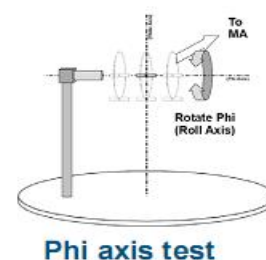
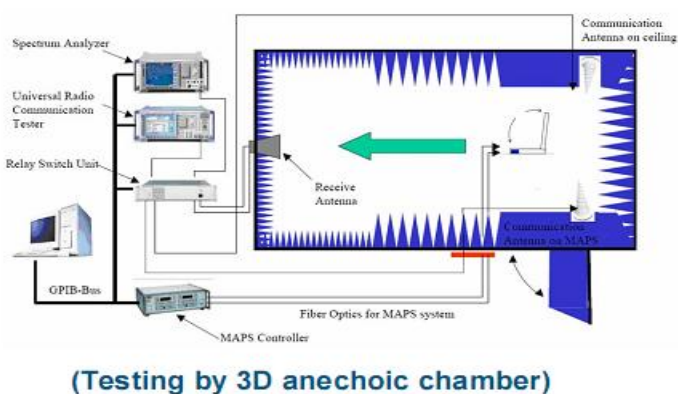

Efficiency & Gain

2.40 -0.01

2.440 0.12

2.48 0.17

Radiation Pattern:

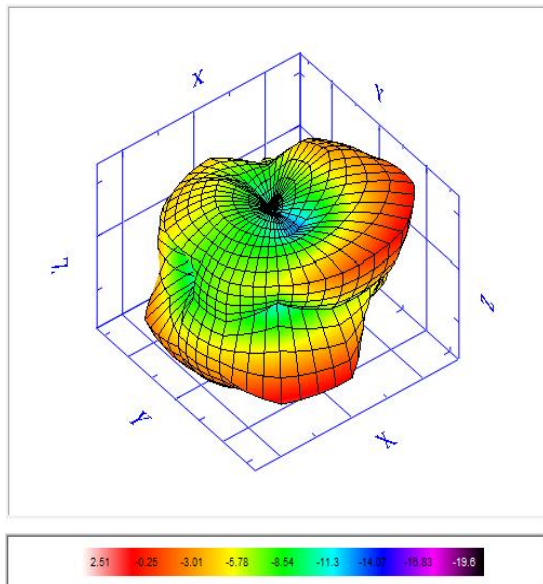
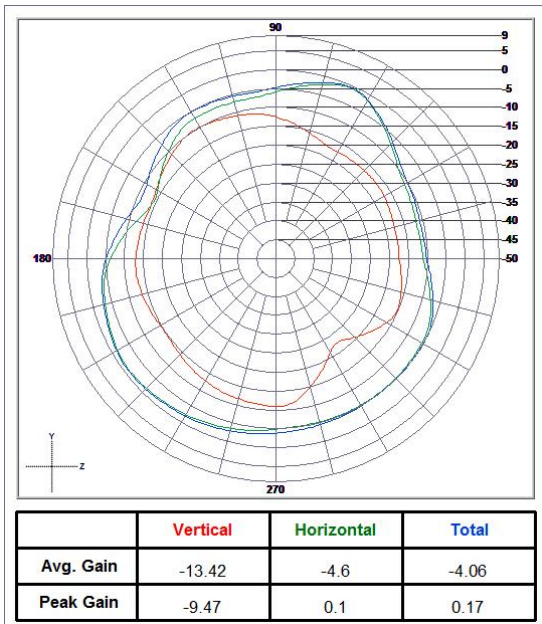
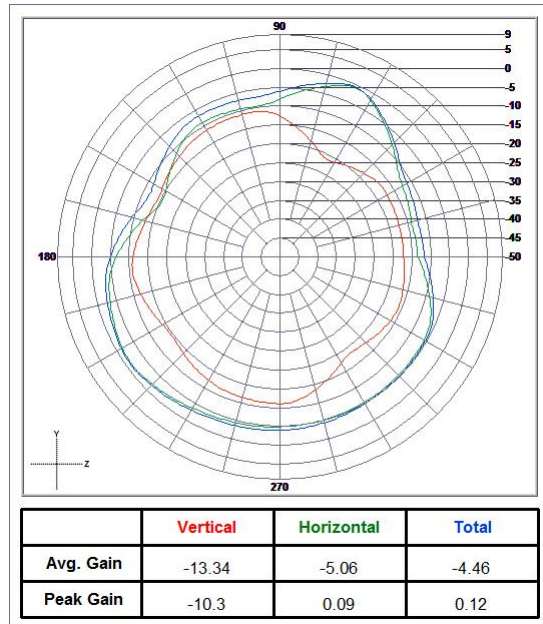
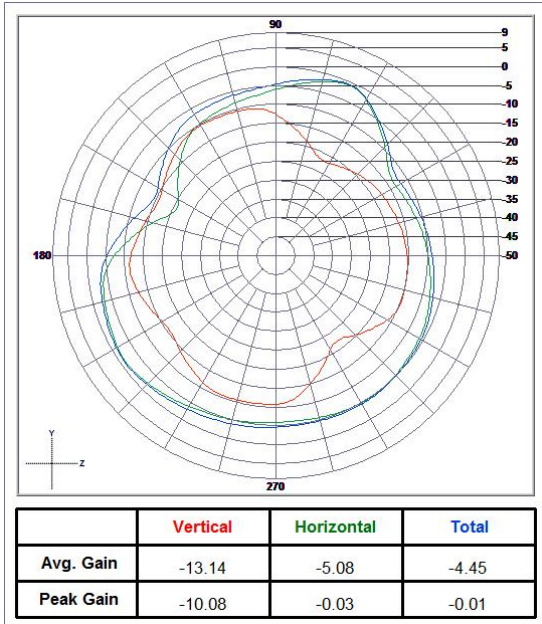

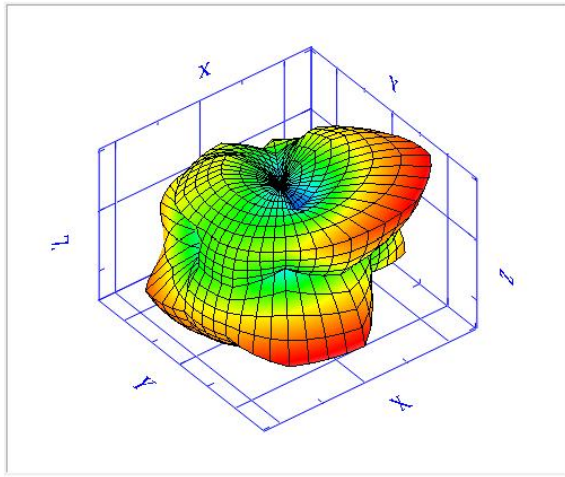

2.12 -0.3 -2.73 -6.16 -10.01 -12.41 -14.82 -17.29

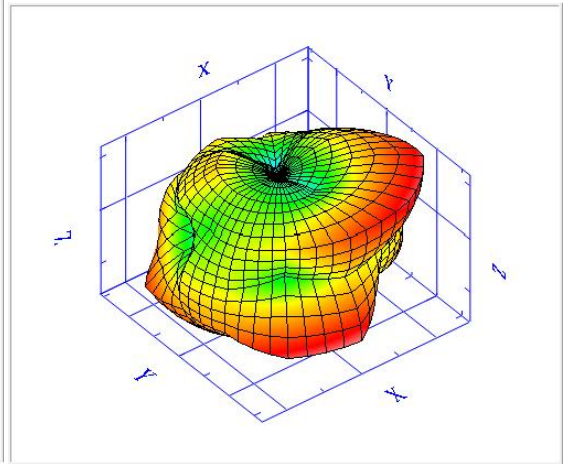

1.98 -0.56 -3.14 -5.7 -8.26 -10.81 -13.37 -15.93 -18.49