



A10 Electric Scooter
USER MANUAL

Contents

Product Features	3
Accessories	3
Specifications	4
Assembly	6
Charger Your Scooter	6
How To Ride	7
Folding	8
Unfolding	9
Phantomgogo APP	10
Safety Precautions	11
Cleaning And Storage	16
Tire Inflation Maintenance	16
Battery Maintenance	16
Environmental Protection	18
After-sales Service	18
Non-warranty Rule	18
Warranty Content	19
User Stub	20
Manufacturer Stub	21
Fault Code	22

Product Features

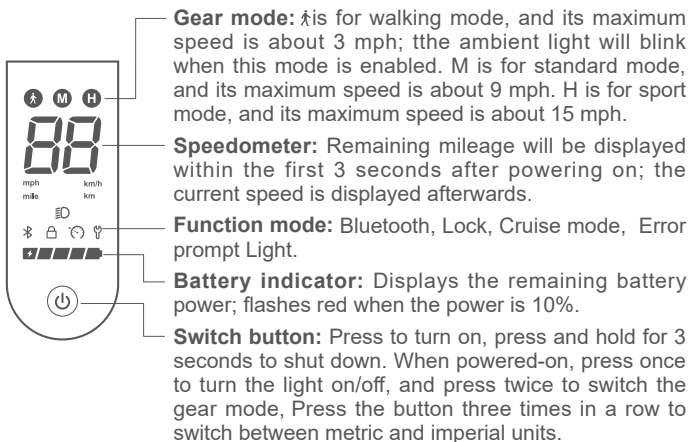
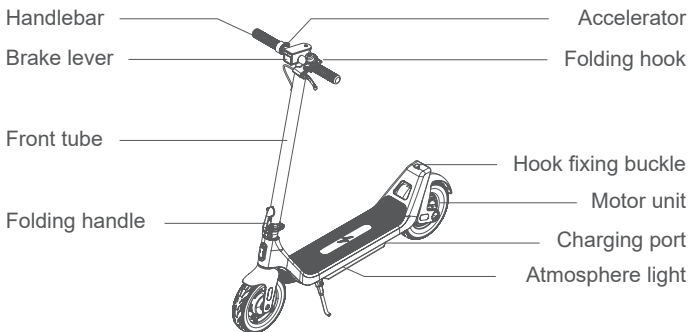

Accessories



User Manual/
Service Card



Power Adapter



T-shape
Allen Key



Screw

Specifications

Product	Name	Electric Scooter
	Model	A10
Dimensions	Vehicle: L × W × H (in)	45×17.5×48
	After Folding: L × W × H (in)	45×17.5×20.3
Net Weight	Vehicle Net Weight (lb)	38.0
Rider	Max. Load (lb)	220
	Age (years)	12+
	Height (in)	4.72~7.87
Assembled Electric Scooter	Max. Speed (mph)	15
	General Range (mile)	Approx. 28
	Max. Climbing Angle (%)	Approx. 15
	Suitable Surfaces	Cement or asphalt road, with benches of less than 1 cm or crevices narrower than 3 cm
	Operating Temperature (°C)	-10 to 45
	Charing temperautre range(°C)	0 to 45
	Storage Temperature (°C)	-20 to 50
	IP Rating	IPX5
	Charging Time (h)	About 6

Battery Pack	Model	C1387A3
	Nominal Voltage (VDC)	36.5
	Max. Charge Voltage (VDC)	42
	Rated Energy (Wh)	365
	Rated Capacity (Ah)	10
	Normal Charging Temperature Range (°C)	0 to 45
	Intelligent Battery Management System	Over-heating, short circuit, over-current, over-discharge, and over-charge protection
Wheel Motor	Rated Power (W)	400
Battery Charger	Model	FY-4201700/ GC72-420170-D
	Output Power (W)	71.4
	Input Voltage (VAC)	100-240
	Max. Output Voltage (VDC)	42
	Rated Output (VDC; A)	42; 1.7
Tire	Front & Back Tires	Pneumatic tire, Ø 10 × 2.125 straight valve, with the materials of natural rubber

Assembly

1. Pull the folding handle upwards until an audible click is heard. then pull the folding handle confirming the lock is in place.
2. Manually connect the handlebar and data cable in the front tube. Once connected, check if the scooter powers on normally.
3. Use the included 6 screws to fasten the handlebars. Further tighten the screws by using the T-shape allen key.

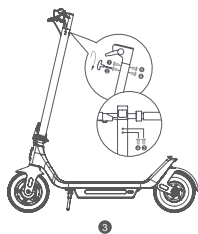
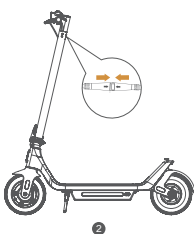
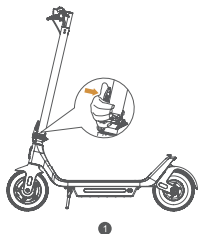

Charge Your Scooter

1. The indicator light of the charger turns green when the scooter is connected to the power supply.
2. When actively charging, the light should switch to red from green.
3. After charging, the indicator light should switch back to green.

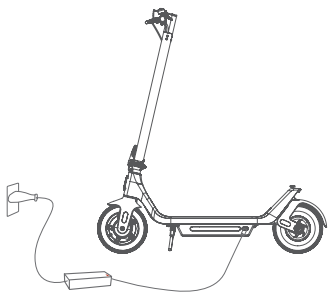

1. Open the rubber flap



2. Plug the power adapter into the charging port



3. Fasten the rubber flap after charging

i Attention:

- Only use the original power adapter when charging.
- Keep away from children and animals when charging, and keep away from flammable materials.
- Do not charge or use the battery if it emits a peculiar smell, overheats or leaks.
- Do not open the battery pack or insert anything into the charging port as the battery contains dangerous substances.
- If it won't be used for a long time, please fully charge it first, store in a cool and dry place, and fully charge it every 30 days.

How To Ride

1. Press the Switch button to turn the scooter on and check the battery level. If the battery level is too low, please charge it before riding.
2. Stand with one foot on the baseboard and kick off against the ground with your other foot. The motor is active once the speed of the scooter exceeds 3 mph.

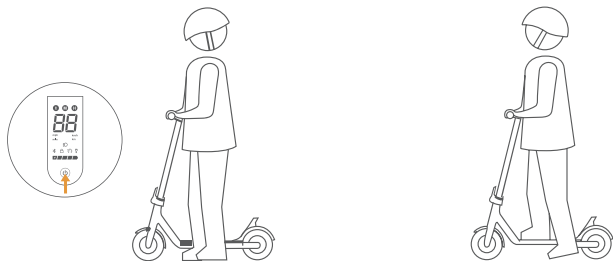

3. While riding, place the other foot on the pedal and lightly press the accelerator to engage the motor.
4. When steering or decelerating, release the accelerator and use the brake lever to brake.

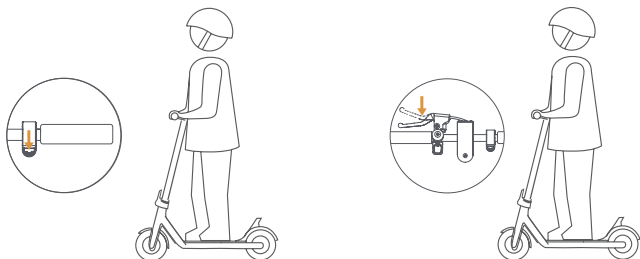

Folding

Turn off the scooter, press the red safety lock, and release the folding handle; fold the front tube clamp, align the folding hook and put it into the hook fixing buckle; lift the front tube and confirm whether it is fastened firmly.

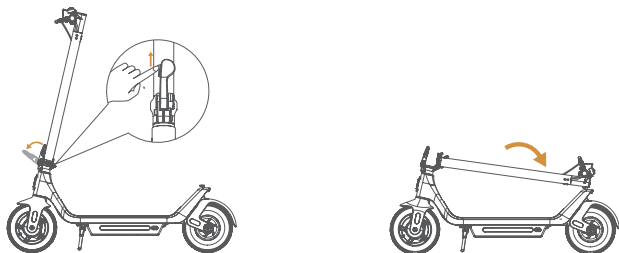

Unfolding

Remove the folding hook from the hook fixing buckle, straighten the front tube, close the folding handle until there is a “click” sound; flip the folding handle and confirm whether it is locked.

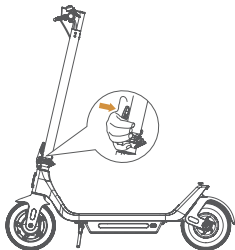
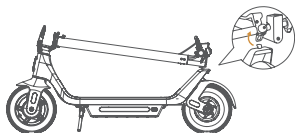

Phantomgogo APP

Scan QR code with your mobile phone to download and install the APP.

i If the APP has been installed on your mobile phone, make sure that the APP is the latest.



STEP 1

Press the button to turn on the scooter and then turn on the Bluetooth function of your mobile phone.



STEP 2

Open the Phantomgogo APP. Please register/log in to your account according to the app instructions.



STEP 3

On the APP homepage, select "Search the binding". The APP will scan the scooter to be configured and add the device according to the prompt in the APP interface.

Zero Start / Non-zero Start Mode

1. Zero Start Mode:

After startup, flick the accelerator dial to activate the accelerator.

2. Non- zero Start Mode:

After startup, the accelerator can be started only when the initial speed is ≥ 3 mph with the help of feet.

3. The factory default of scooter is non-zero start mode.

Scooter Maintenance Schedule (Recommended):

Maintaining the scooter regularly can help keep the scooter neat and in good condition, avoid safety hazards, minimize breakdowns, slow down the deterioration of the scooter, and extend the scooter's service life.

Safety Precautions

1. Please carefully read the User Manual, which will assist in explaining the basic working principles and provide tips on how to best enjoy your scooter experience.
2. Please wear all appropriate safety and protective gear as previously mentioned in the User Manual before operating the scooter.
3. Always wear shoes, make sure to wear comfortable clothes.
4. Do not use any accessories or additional items not approved by the manufacturer with the scooter. Do not try to open or modify your scooter, as doing so will void your manufacture warranty, and may cause failure to your device leading to serious bodily injury or death.
5. **WARNING!** Keep plastic covering away from children to avoid suffocation.
6. Do not operate the scooter while under the influence of drugs and/or alcohol.
7. Do not operate the scooter when you are restless or sleepy.
8. Use your best judgment to keep yourself out of dangerous situations with your scooter.
9. The scooters have a range of about 28miles and a maximum speed of 15mph.
10. Do not turn sharply, especially at high speeds.
11. Do not abuse your scooter, doing so can damage your unit and cause failure to the operating system leading to injury.
12. Do not drive in or near puddles of water, mud, sand, stones gravel, debris or near rough and rugged terrain.
13. The scooter can be used on paved roads that are flat and even. If you encounter uneven pavement, please lift your scooter over and past the obstruction.
14. Do not ride in dangerous weather: snow, rain, hail, sleek, on icy roads or in extreme heat.

15. Do not ride in or near pools or other large bodies of water.
16. Traffic in the city has many obstacles to cross such as curbs or steps. It is important to anticipate and adapt your trajectory and speed to those of a pedestrian before crossing these obstacles. It is also recommended to get out of the vehicle when these obstacles become dangerous due to their shape, height or slippage.
17. Do not attempt to ride over bumps or objects greater than 0.6 inch even when prepared and bending your knees.
18. PAY ATTENTION -look to where you are riding and be attentive of the road conditions, people, places, property and objects around you.
19. Do not operate the scooter in crowded areas.
20. Operate your scooter with extreme caution when indoors, especially around people, property, and narrow spaces like doorways.
21. Pay special precautions in dark environments; be careful not to touch the brake disc.
22. Do not operate the scooter while talking, texting, or looking at your phone.
23. Do not ride your scooter where it is not permitted.
24. Do not ride your scooter near motor vehicles or on public roads.
25. Do not climb or travel down steep hills with your scooter.
26. The scooter is intended for use by a single individual, do not attempt to operate the scooter with two or more people. Do not carry anything while riding the scooter.
27. People who lack balance should not attempt to operate a scooter.
28. Women who are pregnant or are preparing for pregnancy should not operate the scooter.
29. Young children and the elderly should not operate the scooter without proper instruction and supervision from a certified scooter trainer.
30. At higher speeds, always take into consideration longer stopping

distances.

31. Do not step forward off your scooter.

32. Do not attempt to jump on or off your scooter.

33. Do not attempt any stunts or tricks with your scooter.

34. Do not ride the scooter in dark or poorly lit areas.

35. Ride the scooter on the roads or areas permitted by local regulations and laws and park it in the areas permitted. The maximum speed of the scooter is limited to 15 mph. If the local regulations and laws have different provisions on the maximum speed, the local regulations and laws will prevail. Please respect and follow the road safety and vehicle rules.

36. Do not ride the scooter near or over potholes, cracks or uneven pavement.

37. Do not operate your scooter off-road.

38. Do not exceed the maximum weight limit of 220 lbs.

39. Avoid driving the scooter in unsafe places, including near areas with flammable gas, steam, liquid, dust, fiber, which could cause fire and explosion accidents.

40. Scooter users are recommended to be 12+ years and 55 to 78 inch tall.

41. Anticipate your trajectory and your speed while respecting the code of the road, the code of the sidewalk and the most vulnerable. Notify your presence when approaching a pedestrian or cyclist when you are not seen or heard.

42. Walk when crossing protected passages.

43. In all cases, take care of yourself and others.

44. Do not divert the scooter beyond its intended use.

45. This vehicle is not intended for any sort of acrobatic use.

46. Caution, the brakes may become hot after use. Avoid touching them after riding.

47. **WARNING!** It is recommended to perform periodic inspections of the frame, fork and suspension attachments (if any).
48. Regularly check the tightening of the various bolted elements. In particular the wheel axles, the folding system, the steering system and the brake shaft.
49. Do not modify or transform the vehicle, including the steering tube and sleeve, stem, folding mechanism and rear brake.
50. For pneumatic tires, the recommended maximum tire pressure is 45-50 psi.
51. **WARNING!** As with any mechanical component, a vehicle is subject to high stresses and wear. The various materials and components may react differently to wear or fatigue. If the expected service life for a component has been exceeded, it may break suddenly, therefore risking causing injuries to the user. Cracks, scratches and discoloration in the areas subject to high stresses indicate that the component has exceeded its service life and should be replaced.
52. The list regarding general maintenance can be performed by the user themselves without a trained professional.
53. Do not place the scooter in a high temperature higher than 122F or a low temperature lower than -4F. Do not put the scooter into a fire, otherwise it may lead to battery failure, overheating, and even fire risk.
54. When not in use for more than 30 days, fully charge, store in a cool, dry place, and fully charge every 30 days.
55. The equipment contains a radio transmitting module with type approval code CMIT ID: 2020DP3421; Do not use wireless devices in places where the use of wireless devices is prohibited. Otherwise, it may interfere with other electronic devices or cause other risks.
56. Take the time to learn the basics of the practice to avoid any serious accident that can take place in the first few months.
57. Be sure to keep and read the instructions for your future reference.
58. Persons shall be advised not to allow hands, feet, hair, body parts, clothing, or similar articles to come in contact with moving parts, wheels, or drivetrain, while the engine is running. Persons with the

following conditions shall be cautioned not to operate: Those with heart conditions: Persons with head, back, or neck ailments, or prior surgeries to those areas of the body.

59. an intentional or unintentional radiator shall caution the user that changes or modifications not expressly approved by the party responsible for compliance could avoid the user's authority to operate the equipment.

60. it can use silicone oil Emulsion, and model name is YA1 or other models (lubrication), it will help to replace wheel once you want to change tyre.

61. Before each cycle of operation, the operator shall perform the preoperation checks specified by the manufacturer:

62. That all guards and pads originally supplied by the manufacturer are in proper place and in serviceable condition;

63. That the area that the unit is to be operated in is safe and suitable for safe operation;

64. That the braking system is functioning properly;

65. That all safety labels are in place and understood by the operator and any passenger;

66. That any and all axle guards, chain guards, or other covers or guards supplied by the manufacturer are in place and in serviceable condition; and

Cleaning And Storage

If there are stains on the surface of the scooter, use a soft cloth and dip in a small amount of water to wipe; If there are stains that are difficult to clean, smear them with toothpaste and brush them repeatedly, then clean them with a damp cloth. If the plastic parts of the body are scratched, use sandpaper or other abrasive materials to polish them.

i Tips:

Do not use alcohol, gasoline, kerosene or other corrosive and volatile chemical solvents to clean, otherwise it will seriously damage the appearance and internal structure of the body. Do not use pressurized water to spray and wash.

Ensure that the scooter is off and the charging port rubber cover is tightly fastened during cleaning, otherwise electric shock or serious failure may occur due to internal water flow. When not in use, store in a dry and cool place indoors. Avoid outdoor storage for a long time. Long-term sun exposure, overheating and cold outdoor environment will accelerate the appearance and tire aging of the scooter, and reduce the service life of the scooter and battery pack.

Tire Inflation and Maintenance

The product uses puncture-proof tubeless tires, please check the tire pressure carefully before riding, and ensure the tire pressure is 45-50 psi. When the tire height sinks 20%-30%, it is time to inflate. The recommended tire pressure is 45-50 psi after inflation, and the tire should be inflated at least once every 2-3 months. Regular inflation and cleaning of tire surface debris can prolong the service life of the tire.

Battery Maintenance

1. Do not use battery packs of other models or brands, or else there may be safety risks.
2. It is strictly forbidden to disassemble, squeeze, or puncture this

product; it is forbidden to throw this product into water, fire (including heat sources such as stove, heater, etc.) or expose it to an environment with a temperature higher than 122°F.

3. Water entering the battery may cause damage to the internal circuit, and there is a risk of fire or even explosion; if the battery is suspected of water entering, please stop using it immediately and contact the after-sales service.

4. Do not touch the battery contacts, disassemble or puncture the case. Avoid metal objects contacting the battery contacts, or else it may cause short circuits, damage to the battery or personal injury or death.

5. Avoid recharging after the battery is completely depleted, and try to charge as soon as possible to prolong the service life of the battery.

6. Only use the original power adapter when charging, or else there is a danger of damage or fire.

7. Please fully charge the battery before storing it after each use, which will help to extend the battery life.

8. Do not place the scooter in an environment above 122°F or below -4°F (for example: in a car exposed to the sun in summer). It is forbidden to throw the scooter into a fire, or else it may cause the battery to fail, overheat, and even cause fire.

9. When used at normal temperature, the battery pack can exert a higher range and performance; if used in an environment below 32°F, the battery life and performance will decrease.

10. If it won't be used for a long time, please fully charge it first, store in a cool and dry place, and fully charge it every 30 days.

11. Improper disposal of used batteries may seriously pollute the environment. Please abide by local regulations when disposing of the battery pack. Do not throw away the battery pack in order to protect the natural environment.

Environmental Protection

This product contains battery or recyclable electronic waste, and the built-in rechargeable battery contains substances that may pollute the environment. When disposing of the product, please do not pile it with general household waste, but hand it to the electronic waste collection point designated by the state, which is beneficial to environmental protection.

After-sales Service

This product strictly implements the relevant laws and regulations from the date of purchase:

- For problems within 1 month of ownership, users can opt for a replacement scooter.
- For problems within 12 months of ownership, users can abide by the general 1-year parts warranty.

Attention:

You are advised to keep the packing case for at least 1 month from receiving the product.

Non-warranty Rule

Warranty services cease to apply in any of the following cases:

- No warranty voucher or beyond warranty period.
- Product damage ascribed to the failure in using, maintaining and keeping the product as per the manual.
- Damage ascribed to unauthorized dismantling and repairing.
- Damage ascribed to excessive force.
- Normal fade and consumption in normal use.

Warranty Content

Type	Parts	Times
Main Parts	Frame, Hub Motor, Auxiliary Hub, Handlebar, Hood Cover, Front Fork Cover, Folding Riser Set, Mechanical Brake Line	12 Months
Accessories	Battery, Charger, Dial, Headlight, Taillight Brake lever, Instrumentation, Controller	6 Months
Wearing Accessories	Handlebar Grip, Front/Rear Tire, Front Fender, Rear Fender, Silicone Mats, Warning Reflective Stickers, Kickstand, Rubber Plugs, Frame Bottom Covers, Motor Sides decorative Covers, Bells, Reflectors, Atmosphere Light, Instrument Cover, Hook	3 Months

User Stub

User information (Please fill in the real information. User information will only be used for after-sales warranty services).

User name: _____ Phone number: _____

E-mail: _____ Postal code: _____

Address: _____

Product information

Product name: _____ Model: _____

SN code: _____ Color: _____

Date of manufacture: _____

Service: Return Replace Repair

Fault phenomenon: _____

Signature of repairer: _____

Date of acceptance: _____

Manufacturer Stub

User information (Please fill in the real information. User information will only be used for after-sales warranty services).

User name: _____ Phone number: _____

E-mail: _____ Postal code: _____

Address: _____

Product information

Product name: _____ Model: _____

SN code: _____ Color: _____

Date of manufacture: _____

Service: Return Replace Repair

Fault phenomenon: _____

Signature of repairer: _____

Date of acceptance: _____

Fault Code

Code	Description of Fault Content	Solution	Corresponding Parts
00	Undervoltage, low battery	Please charge in time.	Battery
01	Overvoltage, too high battery	Needs to unplug the charger.	Battery
02	Controller Fault	Controller needs to be replaced.	Controller
03	MOS Tube Fault	After 15 minutes of shutdown, restart to confirm whether the fault is resolved; if not, the controller needs to be replaced.	Controller
04	Hardware Communication Fault	Check the connection line between the controller and the display, if the connection is normal, but the fault is not resolved, please call the manufacturer.	Controller/ Display
05	Hall Fault	Check the Hall wire between the controller and the motor. If the connection is normal, but the fault is not resolved, the motor needs to be replaced.	Motor
06	Accelerator Fault	Check the accelerator shift connection cable, if the connection is normal, whether the fault is resolved; if not, replace the shift.	Accelerator

07	Brake Lever Fault	Check the brake lever connection line, if the connection is normal, whether the fault is resolved; if not, the brake lever needs to be replaced.	Brake Lever
08	OCP Protection	Shut down for 5 minutes, then restart to confirm whether the fault is resolved, if not, replace the controller.	Controller
09	Motor Fault	Shut down for 5 minutes, then restart to confirm whether the fault is resolved, if not, replace the motor.	Motor
10	Controller and battery connect error	Check the connect communication cable between controller with battery	Controller and battery



The statements should be displayed in the user manual:

changes or modifications not expressly approved by the party responsible for compliance could void the user's authority to operate the equipment.

This equipment has been

tested and found to comply with the limits for a Class B digital device,

pursuant to Part 15 of the FCC Rules. These limits are designed to provide reasonable protection against harmful interference in a residential installation. This equipment generates, uses and can radiate radio frequency energy and, if not installed and used in accordance with the instructions, may cause harmful interference to radio communications. However, there is no guarantee that interference will not occur in a particular installation.

If this equipment does

cause harmful interference to radio or television reception, which can be determined by turning the equipment off and on, the user is encouraged to try to correct the interference by one or more of the following measures:

- Reorient or relocate the receiving antenna.
- Increase the separation between the equipment and receiver.
- Connect the equipment into an outlet on a circuit different from that to which the receiver is connected.
- Consult the dealer or an experienced radio/TV technician for help.

Scooter Maintenance Schedule (Recommended):

Maintaining the scooter regularly can help keep the scooter neat and in good condition, avoid safety hazards, minimize breakdowns, slow down the deterioration of the scooter, and extend the scooter's service life.

Item	Service Object	Actions	Every month	Every 3 months	Every 500km/ 6 months	Every 1000 km/ 1 year	Every 2000 km/ 2 years
Tires	Tire Pressure	Inflate the tire until its pressure reaches 45–50 psi.	√		√	√	√
	Tire Tread Wear	Check whether the tire is cracked, deformed, worn, etc.			√	√	√
Screws	Handlebar Assembly Screws	Tighten the screw that connects the handlebar assembly with the stem assembly (with the recommended torque of $3.5 \pm 0.2 \text{ N}\cdot\text{m}$).		√	√	√	√
		Tighten the accelerator screw (with the recommended torque of $1.8 \pm 0.1 \text{ N}\cdot\text{m}$).				√	√
		Tighten the brake lever screw (with the recommended torque of $3.5 \pm 0.2 \text{ N}\cdot\text{m}$).				√	√
Functions	Steering	Turn the handlebar 60° to the left and right to make sure the turning angle is correct and the steering is free from resistance and stagnation.				√	√
Important Components	Battery Assembly	Fully charge the scooter before leaving it unused for a long time, and turn it on to charge every 60 days.					√

Distributed by Phantom E-Moto Inc.

Address: 15830 El Prado Unit E Chino, CA 91708

Contact us via email info@phantomgogo.com or call us at 866-570-8755 if you need replacement parts, or have any questions.

We will reply within 24 hours.



B.01.003.467