

深圳旭航通讯科技有限公司

Shenzhen Xuhang Communication
Technology Co., Ltd

Antenna specification

客户 CUSTOMER	Defigo AS
客户料号 CUSTOMER NO.	
供方品名 PART NAME	WIFI 天线
规格名称 SUPPLIER NO.	XH240008-A

客户确认

CUSTOMER APPROVED BY

检验 APPROVAL	审核 CHIEF	批准 SUPERVISOR

设计 DESIGN	审核 CHECK	批准 APPROVAL
Luo	Robert	SHANG

Date: February 24, 2024

TEST REPORTS

频率 Frequency	WIFI(2400~2500MHz; 5150~5850MHz)
阻抗 Impedance	50 Ohm Nominal
驻波比 V.S.W.R	≤2.0
回波损耗 Return Loss	-10dB Max
辐射 Radiation	Omni-directional
增益 Gain(Peak)	2.4G;1.71dBi 5G;2.36dBi
极化方式 Polarization	Linear,Vertical
功率 Admitted Power	1W
连接器 Connector	I-PEX I
Physical Properties	
天线材质 Antenna Material	FPC
线材类型 Cable Type	O.D.1.13mm
工作温度 Operating Temp.	-10-+60℃
存储温度 Storage Temp.	-10-+70℃
线材颜色 Cable Color	CSM81P-A;Black

匹配电路

Matching Circuits

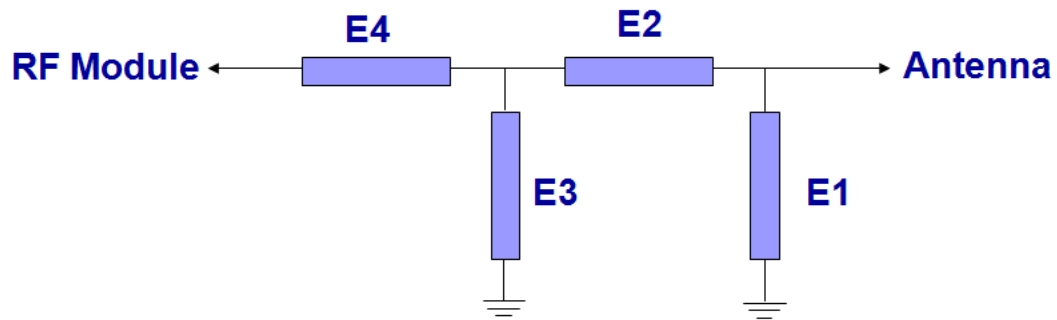

匹配电路

Element	Value	Vender
E1(0402)		
E2(0402)	0Ω	
E3(0402)		
E4(0402)	0Ω	

原匹配电路无修改

The original matching circuit has not been modified

工程图 DRAWING

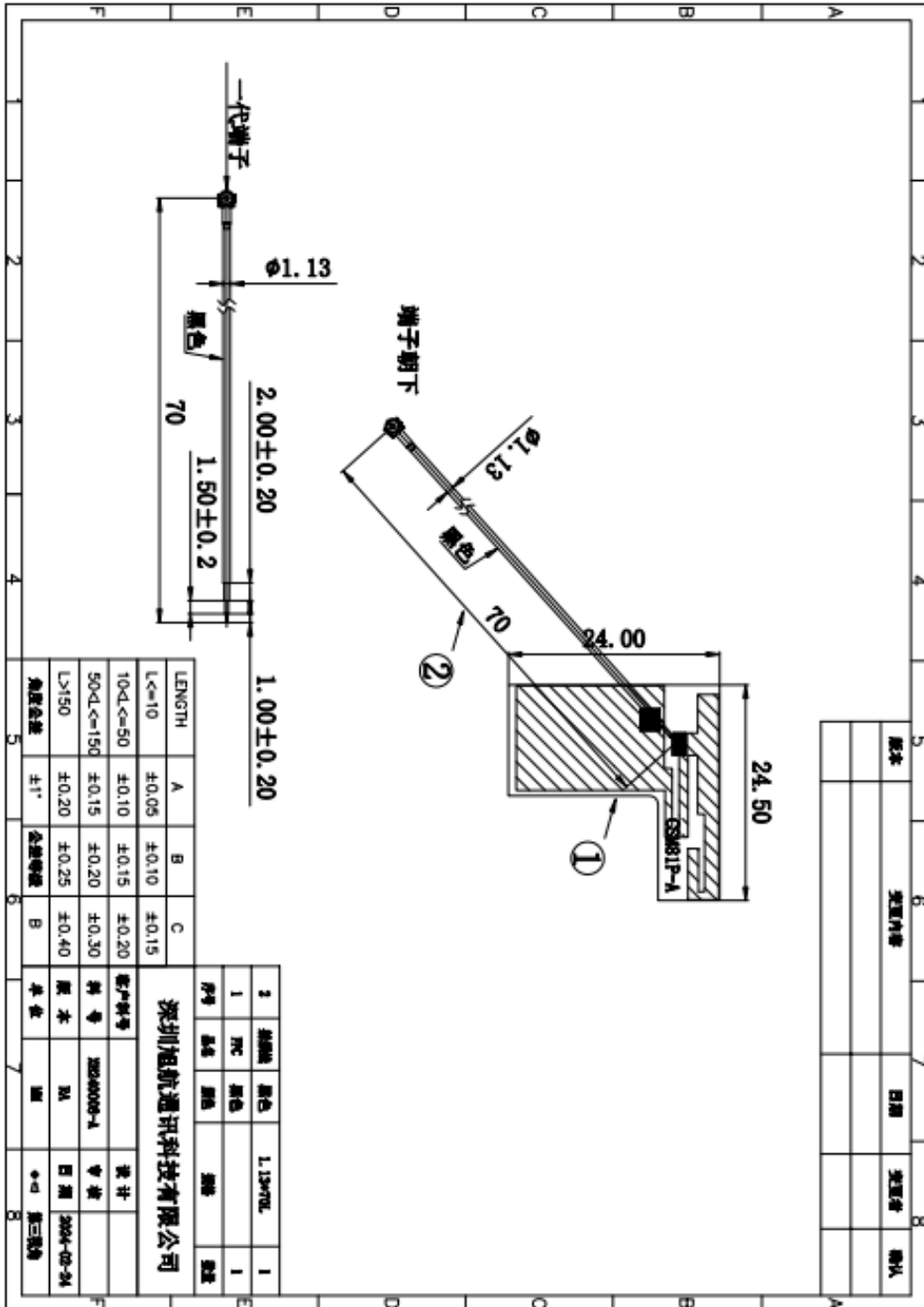

测试数据

Test Data

2.4G

Freq (MHz)	Effi (%)	Gain (dBi)
2400	46.91	0.79
2410	45.88	0.45
2420	50.03	1.43
2430	50.24	1.44
2440	51.68	1.71
2450	46.72	1.16
2460	45.53	0.77
2470	46.39	1.14
2480	45.76	0.52
2490	49.77	1.21
2500	42.98	0.29

5G

Freq (MHz)	Effi (%)	Gain (dBi)
5150	44.81	2.36

3D 方向图

2400.000MHz

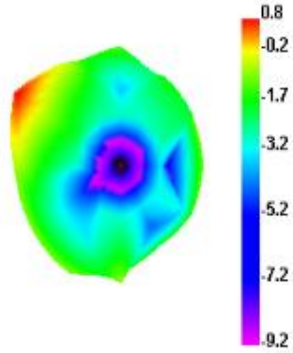

2400.000MHz H

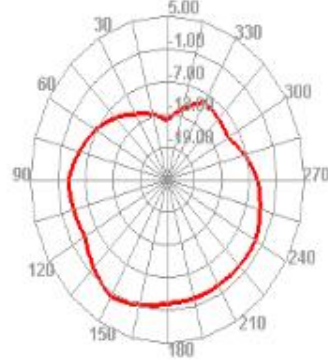

2400.000MHz E1

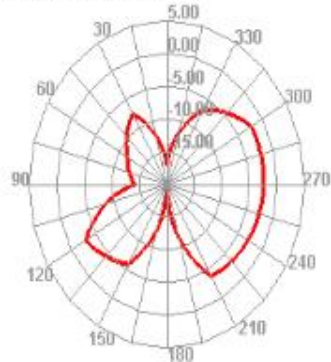

2400.000MHz E2

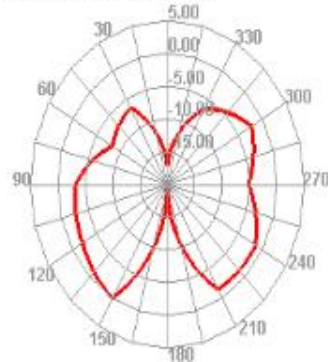

2450.000MHz

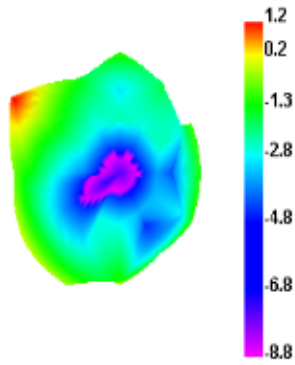

2450.000MHz H

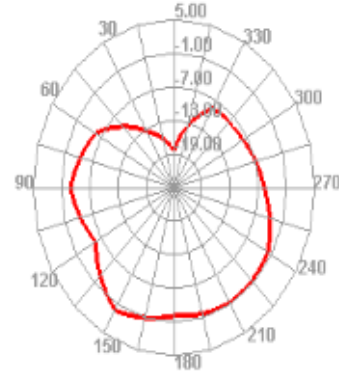

2450.000MHz E1

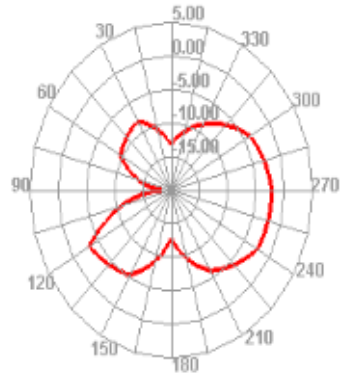

2450.000MHz E2

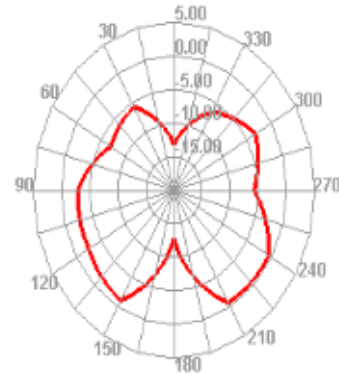

2500.000MHz

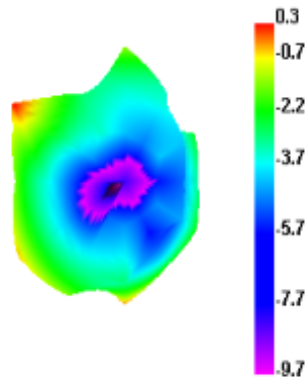

2500.000MHz H

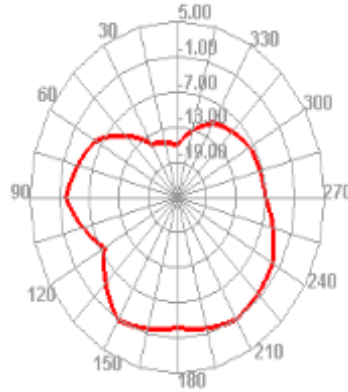

2500.000MHz E1

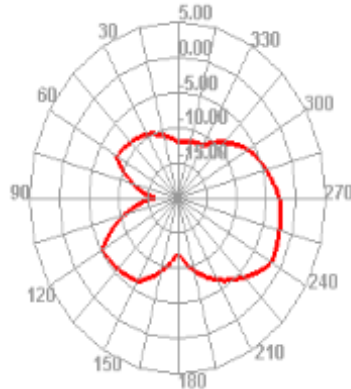

2500.000MHz E2

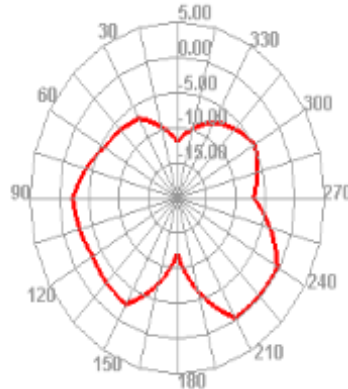

5150.000MHz

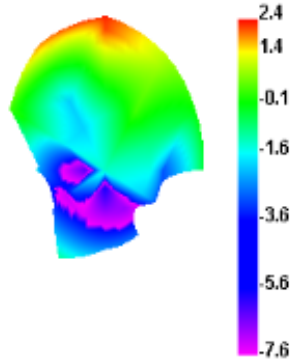

5150.000MHz H

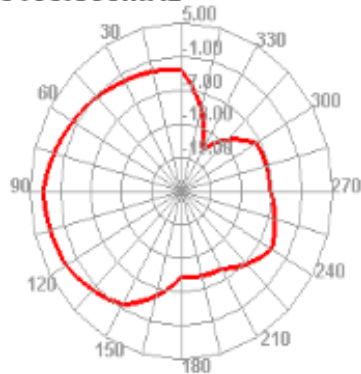

5150.000MHz E1

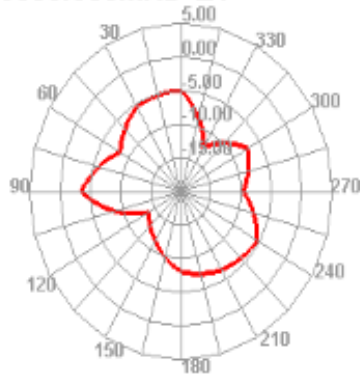

5150.000MHz E2

