

# Quick Start Guide

Apply to: Reolink TrackMix LTE Plus  
+Reolink Solar Panel Plus

## Contents

What's in the Box	2
Camera Introduction	3
Solar panel Introduction	5
Set up the Camera	7
Install the Product	13
Troubleshooting	20
Specification	21
Notification of Compliance	21

## What's in the Box



TrackMix  
LTE Plus

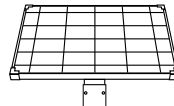

Solar Panel Plus

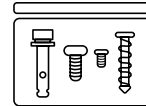

Pack of Screws  
(x4)

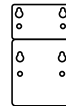

Mounting Template  
(For Camera)

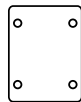

Mounting Template  
(For Solar Panel)



Hex Key  
(x2)

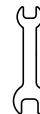

Open End Wrench



Surveillance  
Sticker



Quick Start Guide

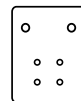

Mounting Plate

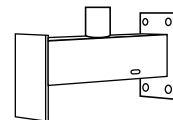

Mounting Bracket

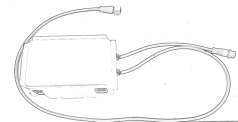

Battery-Li12

## Camera Introduction

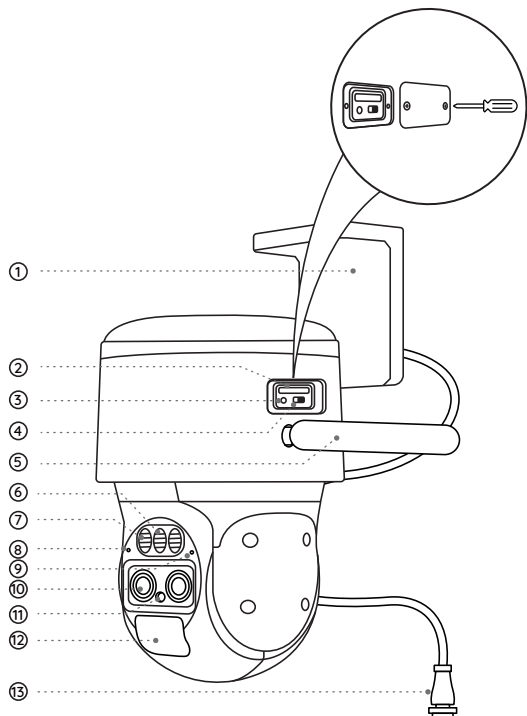

- ① Mount
- ② Nano SIM Card Slot
- ③ Reset Button  
\* Press the reset button with a pin to restore factory settings.
- ④ Power Switch
- ⑤ Antenna
- ⑥ Spotlight
- ⑦ Infrared Light
- ⑧ Built-in Mic
- ⑨ Status LED
- ⑩ Lens
- ⑪ Daylight Sensor
- ⑫ PIR Sensor
- ⑬ Power Port

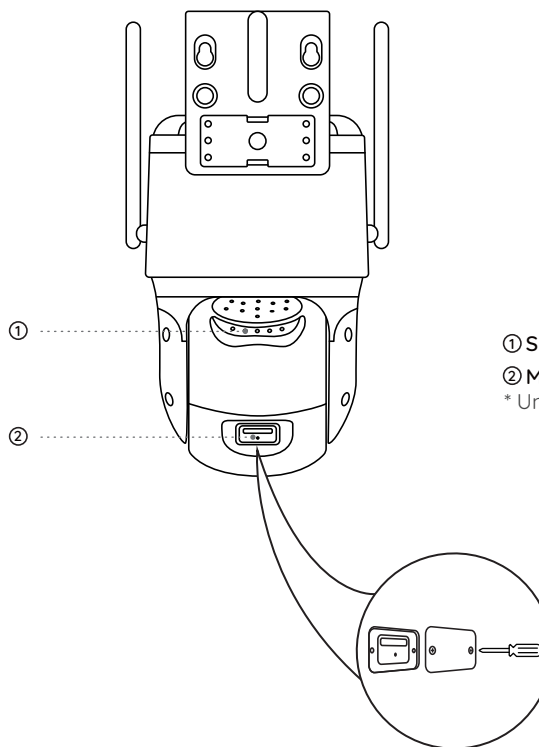

- ① Speaker
- ② Micro SD Card Slot  
\* Unscrew the cover first.

## Solar panel Introduction

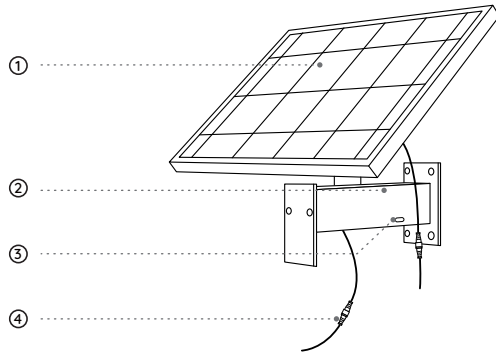

- ① Panel
- ② Battery Pack
- ③ Indicator Light
- ④ Connecting Cable

## Different States of the LED Indicator Light

Each time when you connect the cable from the solar panel to the shorter cable on the battery pack, the green light will be on for 10 seconds, which means the battery pack is ready to work. Then, you can check different states of the indicator light below:

LED Indicator Lights Status		Description
Red Light	Green Light	Solar Panel
Off	Off	Not charging
Off	Solid	Not charging
Off	Blinking	Charging
Solid	Off	Not charging
Solid	Solid	Low charging current or not charging

## Set up the Camera

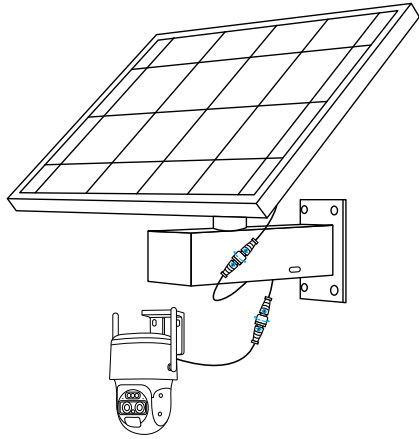

### Power On the Camera

It is required to connect the cable from the solar panel to the shorter cable on the bracket and the camera charging cable to the longer one. Then tighten their gray parts.

**NOTE:** Ensure that the arrows on the two cables are aligned.

### Activate SIM Card for the Camera

- Choose a Nano SIM card that supports WCDMA and FDD LTE.
- Some SIM cards have a PIN code. You may use your smartphone to disable the PIN first.

**NOTE:** Do not insert the IoT or M2M SIM into your smartphone.

### Insert the SIM Card

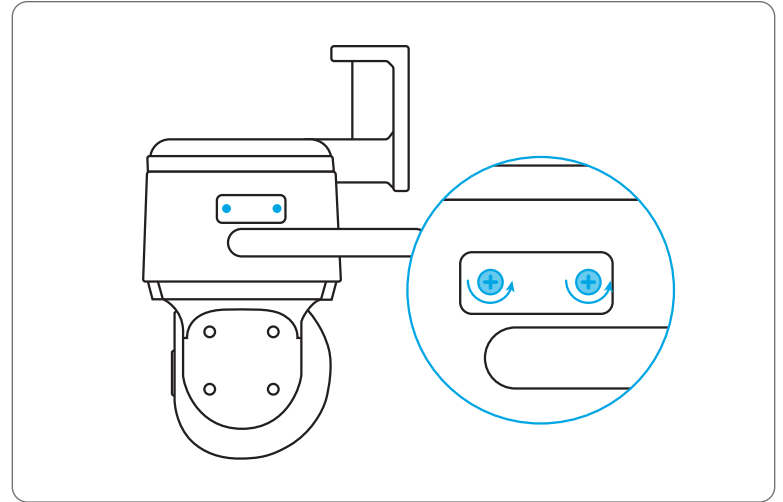

Remove the cover with the screwdriver.

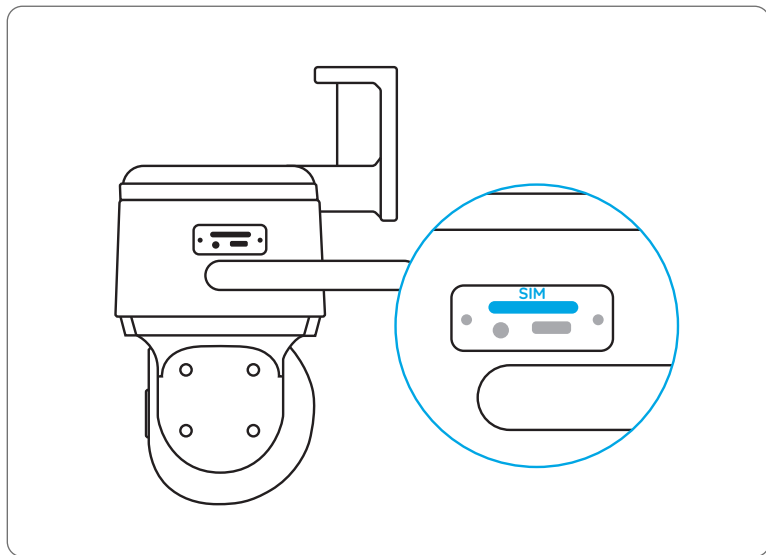

Insert a SIM-eject tool into the hole beside the SIM tray and push it in to pop open the tray. Place the SIM card into the tray, then insert the tray into the camera completely.

## Register the SIM Card

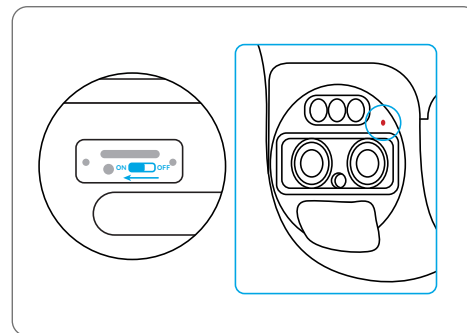

With the SIM card inserted, you can turn on the camera. Wait a few seconds and a red light will be on and solid for a couple of seconds. Then, it will go out.

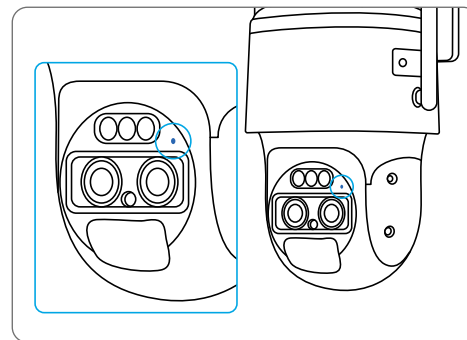

A blue LED will flash for a few seconds and then go solid before going out. You will hear a voice prompt "Network connection succeeded", which means the camera has been successfully connected to the network.

## Set up the Camera on the Phone

**Step 1** Scan to download the Reolink App from the App Store or Google Play store.



**Step 2** Launch the Reolink App, click the “+” button in the top right corner to add the camera. Scan the QR code on the device and follow the onscreen instructions to finish initial setup.

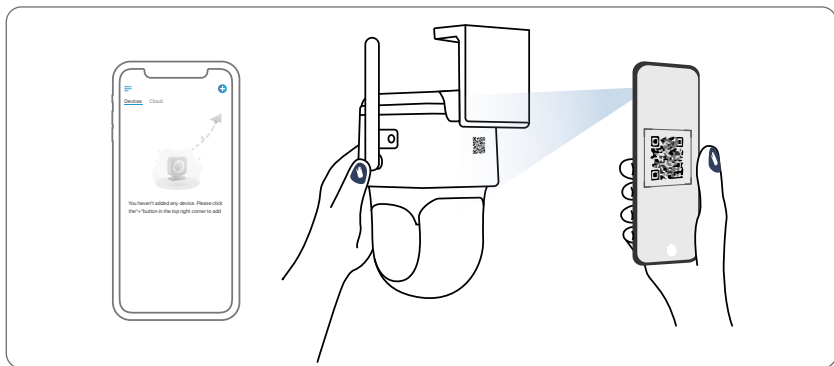

## Set up the Camera on PC (Optional)

**Step 1** Download and install the Reolink Client: Go to <https://reolink.com> > Support > App & Client.

**Step 2** Launch the Reolink Client, click the “+” button, input the UID code of the camera to add it and follow the onscreen instructions to finish initial setup.

**NOTE:** You may also run into the following situations:

Voice Prompt	Camera Status	Solutions
“SIM card cannot be recognized”	Camera cannot recognize this SIM card.	<ol style="list-style-type: none"> <li>1. Check if the SIM card is facing the reverse direction.</li> <li>2. Check if the SIM card is not fully inserted and insert it again.</li> </ol>
“The SIM card is locked with a PIN Please disable it”	Your SIM card has a PIN.	Put the SIM card into your mobile phone and disable the PIN.
“Not registered on network. Please activate your SIM card and check the signal strength”	Camera fails to register to the operator network.	<ol style="list-style-type: none"> <li>1. Check whether your card is activated or not. If not, please call your operator to activate the SIM card.</li> <li>2. The signal is weak at the current position. Please move the camera to a location with better signal.</li> <li>3. Check if you are using the correct version of the camera.</li> </ol>
“Network connection failed”	Camera fails to connect to the server.	The camera will be in Standby mode and reconnect later.
“Data call failed. Please confirm your cellular data plan is available or import the APN settings”	The SIM card has run out of data or APN settings are not correct.	<ol style="list-style-type: none"> <li>1. Please check whether the data plan for the SIM card is still available.</li> <li>2. Import the correct APN settings to the camera.</li> </ol>

## Install the Product

### Notes on Product Installation Position

1. Please choose a location for your solar panel that gets the most sunlight throughout the year. The Reolink solar panel needs only a few hours of direct sunlight to sufficiently power up your camera daily. The amount of energy that the solar panel can produce is affected by weather conditions, seasonal changes, geographic locations, etc

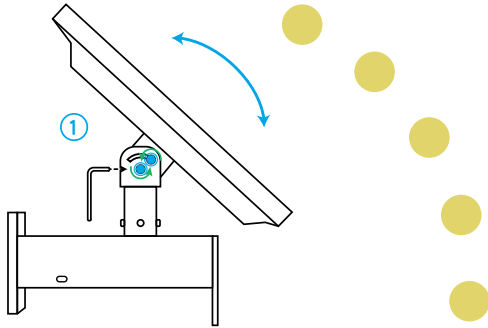

2. Install the camera 2-3 meters (7-10 ft) above ground. This height maximizes the detection range of the PIR motion sensor. For effective detection, please install the camera angularly. Please note that if a moving object approaches the PIR sensor vertically, the camera may fail to detect motion.



## Install the Solar Panel

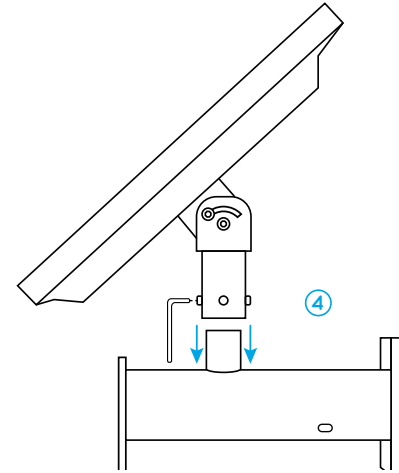
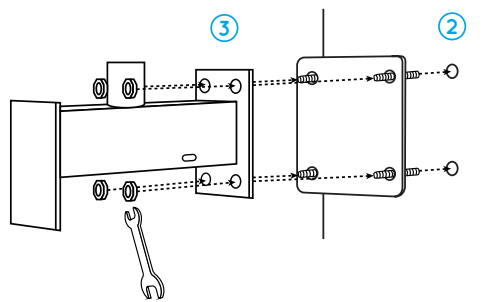
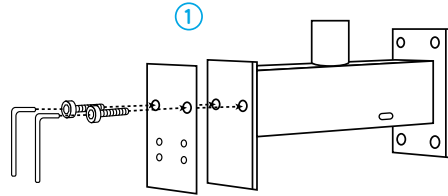

1. Secure the camera mounting base on the mounting bracket with two screws.
2. Drill holes in the desired mounting surface according to the mounting template.
3. Insert the included anchors and attach the mounting bracket to the mounting surface. Use the provided open end wrench to tighten the screws to secure the bracket.

4. Install the solar panel to the bracket. Use the provided Hex Key to tighten the screws and secure the panel in place.

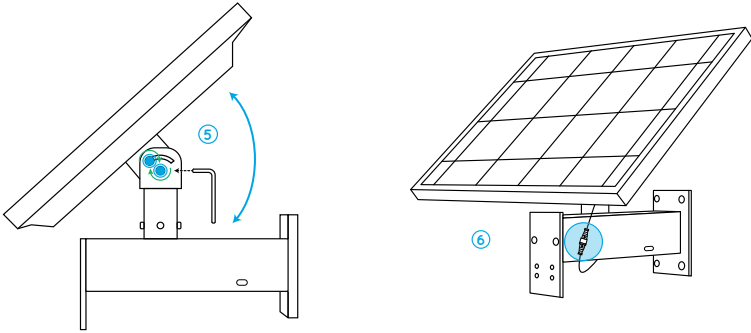

5. Loosen the four screws on two sides of the solar panel's bracket to rotate the panel for maximum sunlight exposure. Then fasten the screws tightly.
6. Connect the cable from the panel to the shorter cable on the bracket. Ensure that the arrows on the two cables are aligned.

### Important notice:

- Make sure the solar panel is not blocked. The energy harvesting efficiency drops drastically even when a small portion of the solar panel is blocked.
- Please don't install the solar panel completely horizontally. Otherwise your solar panel might accumulate dust and other debris easily. It's advised to install the solar panel angularly to receive the most direct sunlight.
- Wipe the solar panel regularly to remove dust or debris.

### Install the Camera

1. It is recommended to attach the camera to the mounting bracket for better waterproof performance.

- (1) Use a screwdriver and two screws to secure the lower part of the camera bracket.
- (2) Fix the upper part with the screwdriver and two screws.
- (3) Connect the camera's charging cable to the longer cable on the bracket.

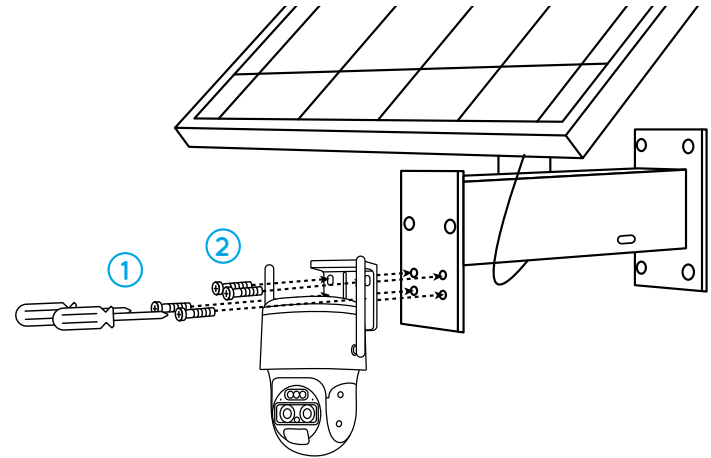

2. You can also install the camera in a different location than the solar panel. For details, see the following steps.

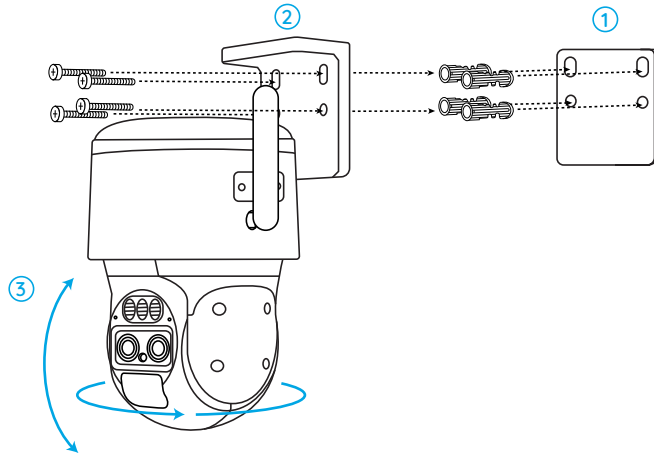

- (1) Drill holes in accordance with the mounting hole template.
- (2) Install the mount base with screws.
- (3) Power the camera by connecting its charging cable to the longer cable on the bracket.
- (4) To adjust the camera direction, you may control the camera to pan and tilt via Reolink App or Client.

## Troubleshooting

### PIR Sensor Fails to Trigger Alarm

If the PIR sensor fails to trigger any kind of alarm within the covered area, try the following solutions:

- Make sure that the camera is installed 2-3 meters (7-10 ft) above ground.
- Make sure that the PIR sensor or the camera is installed in the right direction.
- Make sure the PIR sensor is enabled or the schedule is set up properly and running.
- Check the sensitivity settings and make sure it's set up properly.
- Make sure the battery is working.
- Reset the camera and try again.

If these won't work, please contact Reolink Support <https://support.reolink.com>

### Unable to Receive Push Notifications

If you fail to receive any push notifications when motion is detected, try the following solutions:

- Make sure the push notification has been enabled.
- Make sure the PIR schedule is set up properly.
- Check the network connection on your phone and try again.
- Make sure the camera is connected to the Internet. If the LED indicator under the camera daylight sensor is solid red or flickering red, it means that your device disconnects from the Internet.
- Make sure you've enabled Allow Notifications on your phone. Go to the System Settings on your phone and allow Reolink App to send push notifications.

If these won't work, please contact Reolink Support <https://support.reolink.com>

## Specification

Temperature: -10°C~+55°C  
Humidity: 20% ~ 85%  
Dimension: 228\*147\*129mm

For more information, please visit Reolink official website.

## Notification of Compliance

### CE Declaration of Conformity

#### Simplified EU Declaration of Conformity

Reolink declares that this device is in compliance with the essential requirements and other relevant provisions of Directive 2014/53/EU and Directive 2014/30/EU.

### UKCA Declaration of Conformity

Reolink declares that this product is in compliance with Electromagnetic Compatibility Regulations 2016 and Electrical Equipment Safety Regulations 2016.

### FCC Compliance Statements

This device complies with Part 15 of the FCC Rules. Operation is subject to the following two conditions: (1) this device may not cause harmful interference, and (2) this device must accept any interference received, including interference that may cause undesired operation.

Note: This equipment has been tested and found to comply with the limits for a Class B digital device, pursuant to Part 15 of the FCC Rules. These limits are designed to provide reasonable protection against harmful interference in a residential installation. This equipment generates, uses and can radiate radio frequency energy and, if not installed and used in accordance with the instructions, may cause harmful interference to radio communications. However, there is no guarantee that interference will not occur in a particular installation. If this equipment does cause harmful interference to radio or television reception, which can be determined by turning the equipment off and on, the user is encouraged to try to correct the interference by one or more of the following measures:

- Reorient or relocate the receiving antenna.
- Increase the separation between the equipment and receiver.
- Connect the equipment into an outlet on a circuit different from that to which the receiver is connected.
- Consult the dealer or an experienced radio/TV technician for help.

Caution: Changes or modifications not expressly approved by the party responsible for compliance could void the user's authority to operate the equipment.

### FCC Radiation Exposure statement

This equipment complies with FCC radiation exposure limits set forth for an uncontrolled environment. This equipment should be installed and operated with minimum distance 20cm between the radiator and your body.

### ISED Compliance Statements

This device contains licence-exempt transmitter(s)/receiver(s) that comply with Innovation, Science and Economic Development Canada's licence-exempt RSS(s). Operation is subject to the following two conditions:  
(1) This device may not cause interference.  
(2) This device must accept any interference, including interference that may cause undesired operation of the device.

## ISED Radiation Exposure statement

This equipment complies with IC RSS-102 radiation exposure limits set forth for an uncontrolled environment. This equipment should be installed and operated with minimum distance 20 cm between the radiator and your body.



## Correct Disposal of This Product

This marking indicates that this product should not be disposed with other household wastes throughout the EU. To prevent possible harm to the environment or human health from uncontrolled waste disposal, recycle it responsibly to promote the sustainable reuse of material resources. To return your used device, please use the return and collection systems or contact the retailer where the product was purchased. They can take this product for environmentally safe recycling.

## Limited Warranty

This product comes with a 2-year limited warranty that is valid only if purchased from Reolink Official Store or a Reolink authorized reseller.

Learn more: <https://reolink.com/warranty-and-return/>.

## Terms and Privacy

Use of the product is subject to your agreement to the Terms of Service and Privacy Policy at [reolink.com](https://reolink.com). Keep out of reach of children.

## Déclaration de conformité ISDE

L'appareil contient un émetteur / récepteur exempté de licence conforme au CNR exempté de licence d'innovation, sciences et développement économique Canada.

Les opérations sont soumises aux deux conditions suivantes:

- (1) Cet appareil ne peut pas causer d'interférences.
- (2) L'appareil doit accepter toute interférence, y compris celles qui peuvent entraîner un fonctionnement indésirable de l'appareil.

## Déclaration d'exposition aux rayonnements d'ISDE

L'appareil est conforme aux limites d'exposition aux rayonnements spécifiées dans le CNR - 102 de l'IC pour les environnements non contrôlés. La distance entre le radiateur et le corps doit être d'au moins 20 cm lors de l'installation et du fonctionnement de l'appareil.

