

Shenzhen Sansheng Chuang electronic Technology Co., LTD Letter of acceptance

客 戶:
CUSTOMER: **Shenzhen star Haohao technology Co., LTD**

客 戶 料 號:
CUST P/N:

三盛創 料 號:
FINE P/N: **G4511-6.5UH single coil 0.08*48P*10TS**

產 品 型 號:
DESC: **Φ 43.5MMX5.3MMX0.8MM Double slot openings**

日 期:
DATE: **2023.04.25**

版 本:
Version: **A.0**

擬制 PREPARED BY	審核 CHECKED BY	批准 APPROVED BY	客戶承認 CUSTOMER APPROVE
郭柳	安帥印	安帥印	

Shenzhen Sansheng Chuang electronic Technology Co., LTD

Factory address: 201, Building B, No. 19, Dayang Road, Yulu Community, Yutang Street, Guangming District, Shenzhen

SPECIFICATION

產品型號: DESC	Φ20.5x41-6.5uH-0.8x24P*2P-18mm	版本 Rev: A.0	客戶 CUST: 客戶料号 CUST P/N:	XXX
---------------	--------------------------------	----------------	----------------------------	------------

一、尺寸 DIMENSION:(mm)

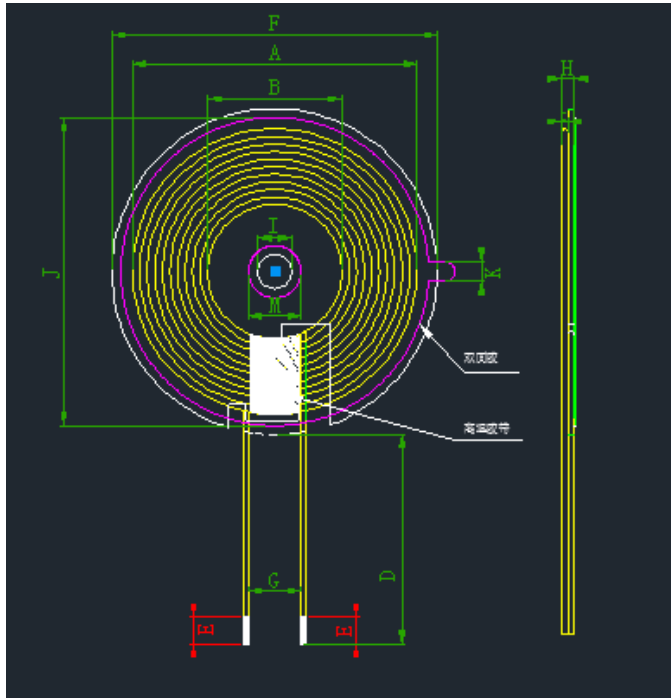

A	41 ± 1
B	20.5 ± 0.5
D	18 ± 2
E	3 ± 1
F	43.5 ± 0.5
G	8
H	1.4 ± 0.1
I	5.3 ± 0.5
J	42.5 ± 1
K	3.0 ± 1

Note:

1. Cross out wire;
2. Wrap 8mm(ref) width high-temperature adhesive paper 1-2Ts around the outlet position;
3. The coil is attached to the circular hard magnetic disc with groove, the magnetic disc size is 43.5 ± 0.5mm, the inner hole is 5.3mm, and the thickness is 0.8 ± 0.1
- 1.4. Wrap wires with adhesive

二、原理图 SCHEMATIC DIAGRAM:

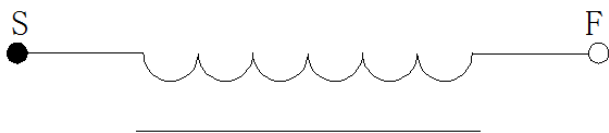

三、绕线参数 Winding Specification:

序号 NO.	端子 TERMINAL		线径 WIRE	圈数 Turns	绕线方向 Winding Direction
1	S	F	热风线 0.08*48P	10Ts	CCW

四、电气特性 ELECTRICAL CHARACTERISTICS:

温度 TEMPERATURE:25 ± 10 °C, 湿度 RELATIVE HUMIDITY:65 ± 20%

序号 NO.	项目 ITEM	端子 TERMINAL	标准 SPECIFICATION	测试条件 TEST FREQUENCY	测试仪器 TEST EQUIPMENTS
1	IND.	S-F	4.2uH ± 3uH 单独线圈	100KHz/1.0V	LCZ METER 1062B
2	IND.	S-F	6.5uH ± 3uH 加磁片	100KHz/1.0V	LCZ METER 1062B
3	DCR	S-F	≤ 43mΩ	100KHz/1.0V	LCZ METER 502B
4	Q	S-F	≤ 78	100KHz/1.0V	LCZ METER 502B

拟制/日期 PREPARED BY/DATE

审核/日期 CHECKED BY/DATE

郭柳 2023.04.25

安帅印 2023.04.25