

深圳市三盛创电子科技有限公司
Shenzhen Sansheng Chuang Electronic
Technology Co., LTD

承 認 書

客 戶: 深圳市唯读立科技有限公司
CUSTOMER: Shenzhen Weili Technology Co., LTD

客 戶 料 號:
CUST P/N:

三盛创 料 號: G4511-6.5UH unicoil0.08*48P*10TS
FINE P/N:

產 品 型 號: Φ 43.5MMX5.3MMX0.8MM Double groove opening
DESC:

日 期: 2023.04.25
DATE:

版 本: A.0
Version:

擬制 PREPARED BY	審核 CHECKED BY	批准 APPROVED BY	客戶承認 CUSTOMER APPROVE
郭柳 Guo Liu	安帅印 Anshuai seal	安帅印 Anshuai seal	

深圳市三盛创电子科技有限公司
Shenzhen Sansheng Chuang Electronic Technology Co., LTD

工廠地址: 深圳市光明区玉塘街道玉律社区大洋一路 19 号 B 栋 201

SPECIFICATION

產品型號: DESC	$\Phi 20.5 \times 41 - 6.5 \mu H - 0.8 \times 24P * 2P - 18mm$	版本 Rev: A.0	客戶 CUST: 客戶料号 CUST P/N:	XXX
---------------	--	----------------	----------------------------	------------

一、尺寸 DIMENSION:(mm)

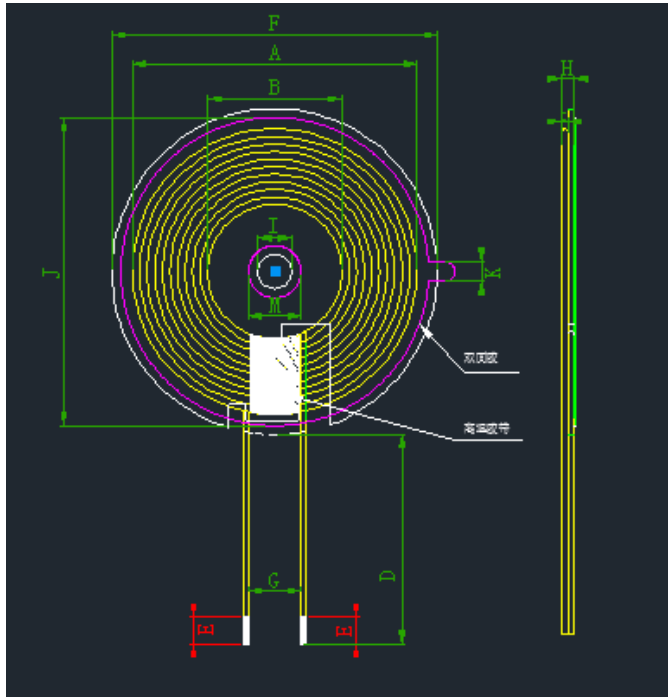

A	41 ± 1
B	20.5 ± 0.5
D	18 ± 2
E	3 ± 1
F	43.5 ± 0.5
G	8
H	1.4 ± 0.1
I	5.3 ± 0.5
J	42.5 ± 1
K	3.0 ± 1

注:

- 1.交叉出线;Cross line
- 2.出线位置缠 8mm(ref)宽度高温胶纸 1-2Ts;8mm (ref) width high temperature adhesive tape 1-2Ts
- 3.线圈贴圆形硬磁片带槽，磁片尺寸 43.5 ± 0.5mm,内孔 5.3mm,厚度为 0.8 ± 0.1。The coil is attached with circular hard magnetic sheet with groove, magnetic sheet size 43.5 ± 0.5mm, inner hole 5.3mm, thickness of 0.8 ± 0.1
- 4.引线包胶。The lead coating glue

二、原理图 SCHEMATIC DIAGRAM:

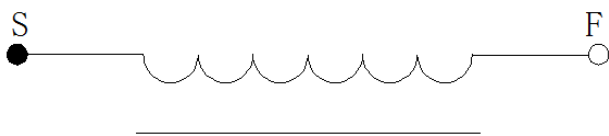

三、绕线参数 Winding Specification:

序号 NO.	端子 TERMINAL		线径 WIRE	圈数 Turns	绕线方向 Winding Direction
1	S	F	Hot wind line 热风线 0.08*48P	10Ts	CCW

四、电气特性 ELECTRICAL CHARACTERISTICS:

温度 TEMPERATURE:25±10℃, 湿度 RELATIVE HUMIDITY:65±20%

序号 NO.	项目 ITEM	端子 TERMINAL	标准 SPECIFICATION	测试条件 TEST FREQUENCY	测试仪器 TEST EQUIPMENTS
1	IND.	S-F	4.2uH ±3uH 单独线圈 Separate coil	100KHz/1.0V	LCZ METER 1062B
2	IND.	S-F	6.5uH ±3uH 加磁片 Add magnetic sheet	100KHz/1.0V	LCZ METER 1062B
3	DCR	S-F	≤43mΩ	100KHz/1.0V	LCZ METER 502B
4	Q	S-F	≤78	100KHz/1.0V	LCZ METER 502B

拟制/日期 PREPARED BY/DATE

审核/日期 CHECKED BY/DATE

郭柳 2023.04.25

安帅印 2023.04.25