

AC 三乙0三

Under Desk Treadmill

User Manual

Model S30

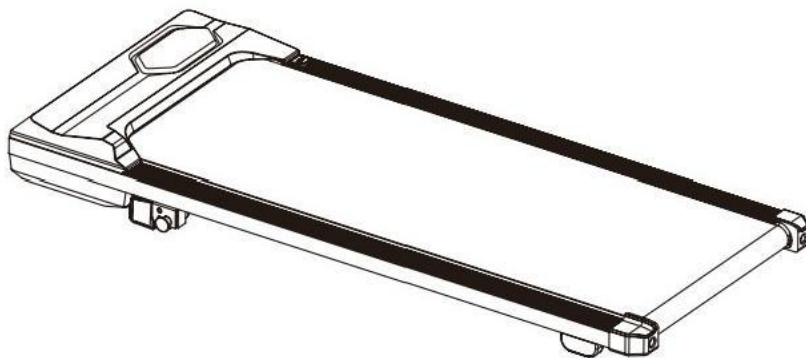

Born for a Healthier Life!

US

CONTENT

1. After -sales Service	03
2. Important Safety Warning	04
2.1 Precautions Before Use	04
2.2 Precautions While Using	04
2.3 Storage and Maintenance Precautions	05
2.4 Precautions for Coin Cell Batteries	05
3. Overview & Accessories-	06
3.1 Package List	06
3.2 Product Overview	07
3.3 LED Display	08
3.4 Remote Control	09
4. Assembly	10
4.1 AssemblyPreparation	10
4.2 How to Install	10
5. How to Use	11
5.1 Slope Adjusting	11
5.2 Start / Pause/ Stop	12
5.3 Free Run	12
5.4 Countdown Mode	12
5.5 Built-in Program	13
5.6 Sleep Mode	14
6. How to Use with APP	14
6.1 APPDownload	14
6.2 Connect & Control Device	15
6.3 Functions	16
7. Storage & Maintenance	17
7.1 Storage	17
7.2 General Maintenance	19

7.3 Running Belt Adjustment.....	19
7.4 Running Belt Lubrication.....	21
7.5 Remote Control Battery Replacement.....	22
7.6 Product Cleaning.....	22
8. Specification Parameters.....	23
9. Troubleshooting	24
10. Warranty	25
11. FCC Statement	27
12. Disposal	27
13. Return & Warranty Process	28

1. After-sales Service

✔ Please do not disassemble, repair or return the machine before contacting Acezoe Support Team.

For damaged or defective products, questions, replacement parts or any other services support, please feel free to contact our customer service department as below.



Email our Customer Service to get more help: support01@acezoe.us



Acezoe is glad to serve you, we will get back to you within 1 business day.



Scan this QR code or browse Acezoe official website to get more product Installation Guide:

www.acezoe.us



2. Important Safety Warning

 **ATTENTION: Before using this machine, please read all instructions in the manual and cautionary markings on the machine carefully.**

2.1 Precautions Before Use

- This product only works under 120V/60Hz voltage. Be sure to use a power socket with safety ground. The grounding plug must be installed and grounded according to the parameters specified locally. If the plug does not match the socket, ask qualified electricians or after-sales staff to handle it.
- Be careful not to place the treadmill on items such as thick carpets, so as not to affect the air circulation under the treadmill. ▲
- Keep the room well ventilated when using the treadmill
- Do not use or store in places exposed to direct sunlight, high-temperature places such as around stoves, or heating appliances such as electric blankets, which may cause electric leakage or fire. ▲
- Do not use with wet hands! Do not pull out or insert the power plug with wet hands to avoid electric shock or injury. ▲
- Do not use the product in a state where the outside of the product is cracked, damaged, or peeled off (the internal structure is exposed), or when the welding part is peeled off
- Do not use if the power cord or plug is damaged, or if the outlet jack is loose, which may result in electric shock, short circuit or fire. ▲

2.2 Precautions While Using

- Barefoot exercise is strictly prohibited. Please do warm-up exercise before exercise to avoid body strain
- Please stop exercising immediately and consult a doctor if you feel unwell or have abnormalities during use.
- Patients who are being treated by a doctor should be sure to use this product only after discussing with a specialized doctor, especially those who have suffered injuries to the legs, waist and neck; those who have deforming arthritis, rheumatism, gout; those who have osteoporosis; those who have heart disease, vascular disorders, high blood pressure, and so on; people with obvious poor health condition.
- Do not jump up and down during exercise to avoid falling and getting injured.
- Do not let children approach treadmill in use to avoid accidents. Pay attention to the surrounding people not to get close during using.
- Do not use this machine with two or more people at the same time, which may result in an accident or fall injury.
- Persons who are indisposed, mentally disabled or lack common sense are not allowed to

- use it, unless under the supervision and guidance of persons responsible for their safety.
- Minors must be accompanied by adults when using treadmill
- Avoid long-term overload operation. It is recommended that turn off the power after 2 hours of continuous use and let the machine rest for 10 minutes before using it
- Please turn off the power switch after exercise. Pull out the power plug from the socket when not in use to avoid the deterioration of the insulation due to dust and moisture, which may lead to electric leakage and fires. ▲

2.3 Storage and Maintenance Precautions

- Please be sure to unplug the power plug of the treadmill before cleaning, maintaining and moving the product. ▲
- Open the motor protection cover at least once a year to vacuum and clean the motor.
- Add 10ml of lubricating oil every 3 months to maintain the machine. Silicone oil must be placed out of the reach of children to avoid serious consequences by accidental ingestion.
- Store the treadmill indoors to avoid moisture and do not place any foreign objects. Do not expose the motor or operating parts to water or liquids, to avoid electric shock or fire. ▲
- If there is any problem with this machine, please contact Acezoe Support Team. Non-professionals, please do not attempt to disassemble or repair it to avoid equipment damage.

2.4 Precautions for Coin Cell Batteries

- Ensure the batteries are installed correctly according to polarity (+ and -).
- Do not mix old and new batteries, different brands or types of batteries, such as alkaline carbon-zinc, or rechargeable batteries.
- The compatible battery type is CR2025.
- The nominal battery voltage is 3V.
- Remove and immediately recycle or dispose of batteries from equipment not used for an extended period of time according to local regulations.
- Always completely secure the battery compartment. If the battery compartment does not close securely, stop using the product, remove the batteries, and keep them away from children.
- Non-rechargeable batteries are not to be recharged.
- Do not force discharge, recharge, disassemble, heat or incinerate. Doing so may result in injury due to venting, leakage or explosion resulting in chemical burns. ▲
- Remove and immediately recycle or dispose of used batteries according to local regulations and keep away from children. Do NOT dispose of batteries in household trash or incinerate. ▲
- Even used batteries may cause severe injury or death. ▲
- Call a local poison control center for treatment information.

SAVE THESE INSTRUCTIONS

3. Overview & Accessories

3.1 Package List

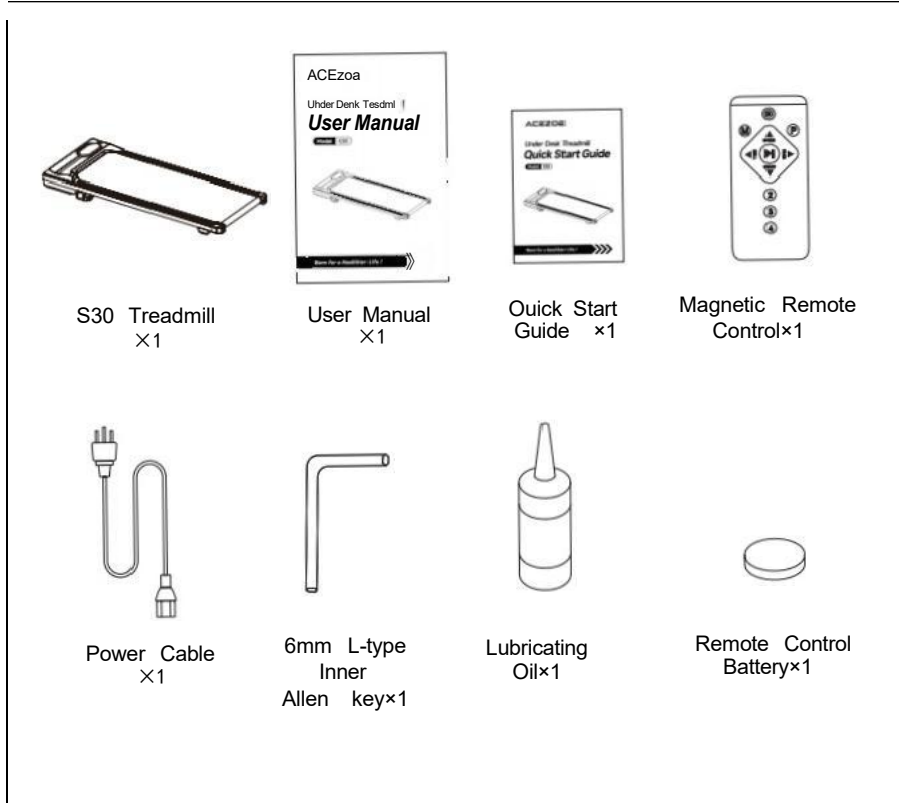

3.2 Product Overview

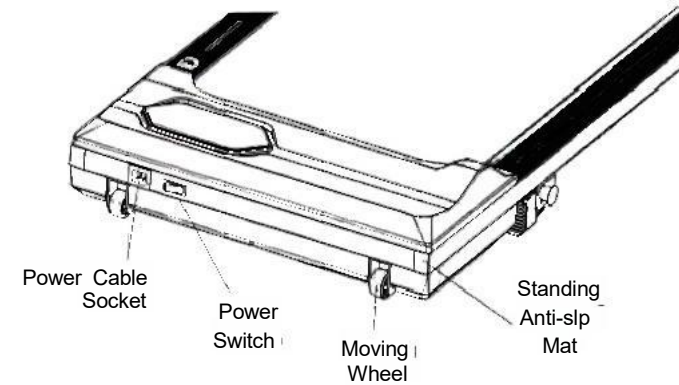
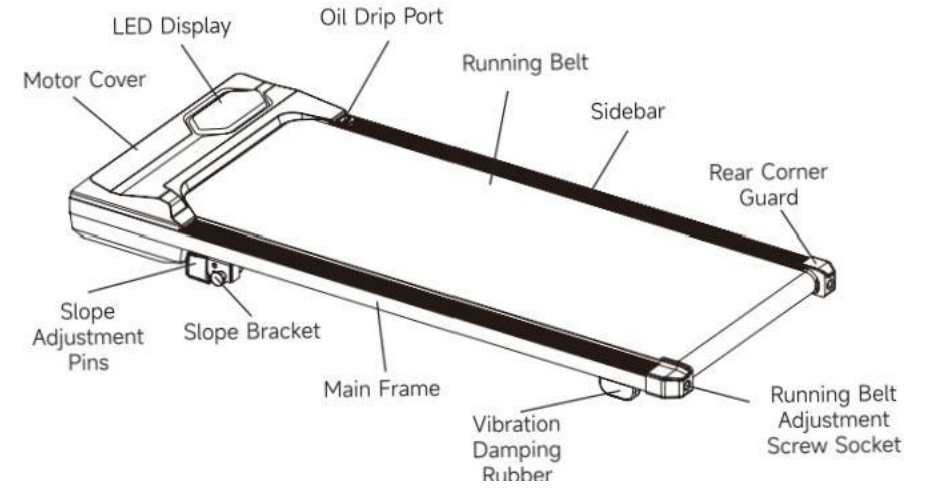

3.3 LED Display

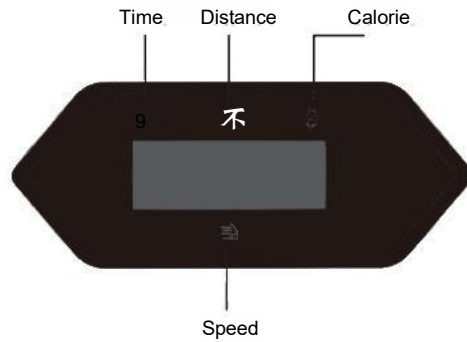

Display Value on Display

Indicator	Meaning of Value
Distance	<ul style="list-style-type: none"> The current exercising distance during exercise. The target distance value, when setting in the countdown mode.
Speed	<ul style="list-style-type: none"> The current speed during exercise.
Time	<ul style="list-style-type: none"> The current exercising time during exercise. The target time value, when setting in the countdown mode. The countdowns of "3"- "2"- "1" in turn during startup.
Calorie	<ul style="list-style-type: none"> The current value of calories burned during exercise. The target calorie value, when setting in the countdown mode.

3.4 Remote Control

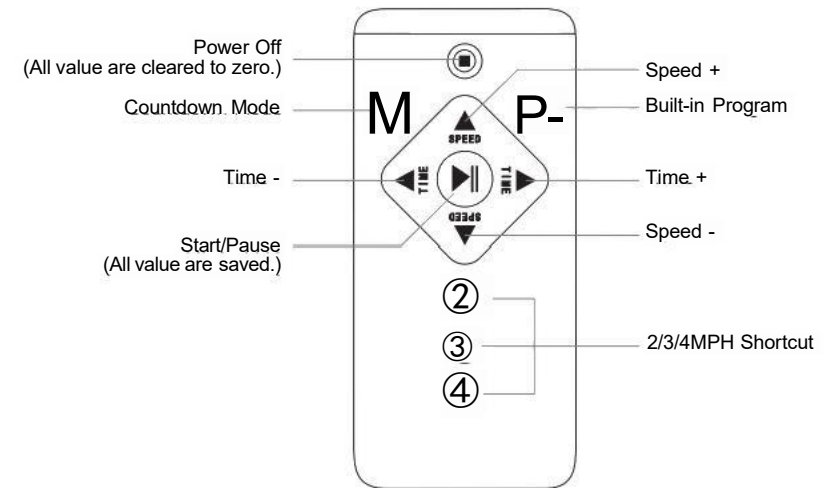

Button	Function
0	Press to stop the treadmill during running. The speed slowly decreases and all value will be cleared to zero.
▶ II	Press to start the treadmill. It will start running after a 3s countdown. Press again to pause the treadmill and retain the current distance, time, and calorie value.
M	<ul style="list-style-type: none"> In standbymode, press the button to enter the countdown mode setting Press once, twice, or three times to set the countdown target values for H1-time, H2-speed, and H3-distance respectively.
P	<ul style="list-style-type: none"> In standby mode, press the button to enter the built-in program setting. Press to choose from built-in P01~P12 programs, the speed changes differently for each program.
2/3/4	The treadmill will accelerate SPEED to 2/3/4 MPH directly.
▲/▶	Increase speed, time, distance, and calorie values.
V1	Decrease speed, time, distance, and calorie values.



TIPS:

Please remove the insulating tabs from the battery when using the remote control for the first time.

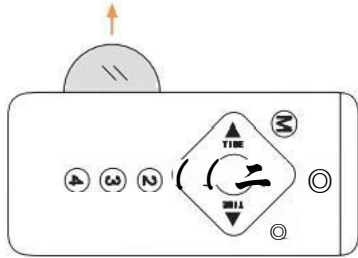

- ② Connect the power cord to a grounded 120V/160Hz outlet only. Turn the power switch to the "—" position to start using the product

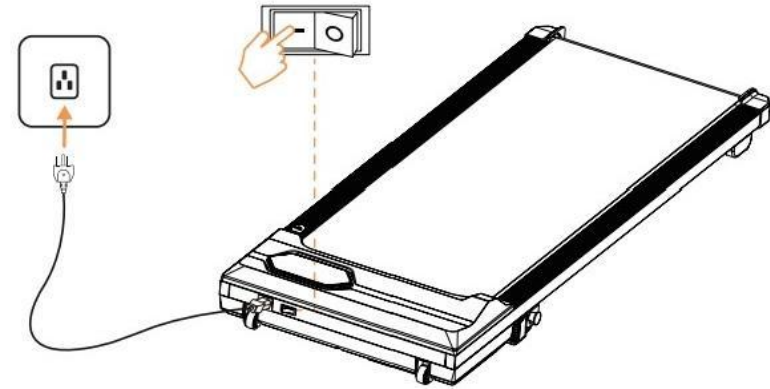

4. Assembly

4.1 Assembly Preparation

- For safety operation, please select a safe, dry, solid and spacious horizontal surface for installation.
- After receiving the product, take out all parts from the product package. Please carefully check whether the parts and tools are complete according to the packing list.

4.2 How to Install

- ① Place the treadmill on a flat ground, stay away from thick carpeting and keep the air circulating.

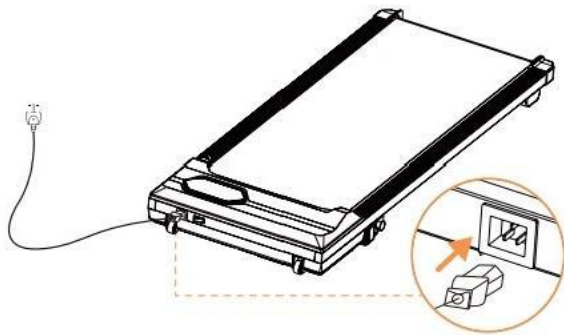

5. How to Use

Before use, make sure that:



- Wear appropriate athletic shoes and keep the laces fastened. Barefoot exercise is strictly prohibited.
- Don't place the treadmill on a thick blanket to avoid affecting the heat dissipation of the machine

5.1 Slope Adjusting

No Incline

- When the slope bracket is placed horizontally, fully insert the slope adjustment pins into the lower holes.

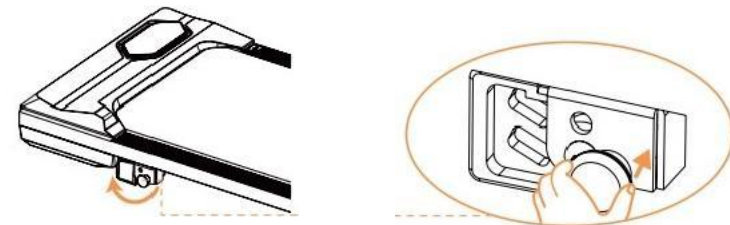

With Incline

- Remove the fixed slope adjustment pins, rotate the slope bracket to make it vertical, then fully insert the slope adjustment pins into the upper holes.



5.2 Start /Pause /Stop

- Press the ">||" button on the remote control, the treadmill will start after a 3s countdown
- During exercise, press the ">||" button again, the treadmill pauses slowly, the speed is cleared to zero, other data remains in the current state, and the screen is always lit
- During exercise, press the "⊙" on the remote control, the treadmill stops running, all data are cleared to zero.

5.3 Free Run

- Press the ">||" button, the machine starts running at 0.5MPH after a 3s countdown
- Press "Speed-/Speed +" or "2/3/4" speed shortcut to adjust the speed (minimum 0.5MPH, maximum 4.0MPH). Distance, time and calorie data will keep increasing during running.

Tips:

After 99:59 minutes of exercise, the machine stops automatically, press ">||" button to restart, the time starts counting from zero again.

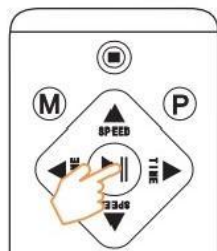

5.4 Countdown Mode

In this mode, the value of time, distance, and calories can be set as target countdown value on demand.

- In standby mode, press the "M" button on the remote control to enter the countdown mode;
- Press the "M" button to cycle switch: "H1-Time" - "H2-Distance" - "H3 - Calorie" - "Standby". The selected window value flashes
- Press the "▲V" button to add and decrease the value of the current window;
 - "Time" Countdown: Value defaults to 30 minutes (settable value range: 5-99 Minutes)
 - "Distance" Countdown: Value defaults to 1 mile (settable value range: 1-99 Miles)
 - "Calorie" Countdown: Value defaults to 50 kcal (settable value range: 20-990 kcal)
- After setting, press the ">||" button, the treadmill starts from the lowest speed (0.5MPH) after a 3s countdown. The speed also can be adjusted on demand.
- When the value set by countdown mode on the window drops to "0", the treadmill will slowdown and stop automatically.

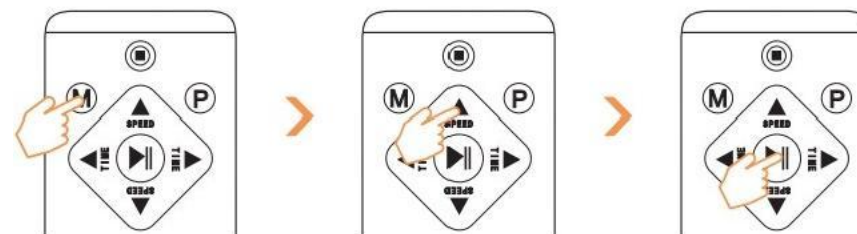

5.5 Built-in Program

There are 12 different programs built into the treadmill, each program varies in speed. Each program is divided into 10 segments, and the running time of each segment is set time /10.

- In standby mode, press the "P" button to select any built-in program from P01 to P12;
- At this time, the "Time" window displays the default value (30mins) and flashes. Press the "▶" buttons to adjust the required exercising time (settable value range: 5-99 Minutes);
- Press the ">||" button, after a 3s countdown, the treadmill will start to run at the speed of the first segment of the selected program;
- When first segment of the program is finished, the treadmill will automatically enter the next segment of the program and change to the preset speed;
- While running, press the "▲V" key to adjust the speed on demand, but the treadmill will automatically change to preset speed while entering the next segment;
- When all segments of the program are finished, the treadmill will slowdown and stop automatically.

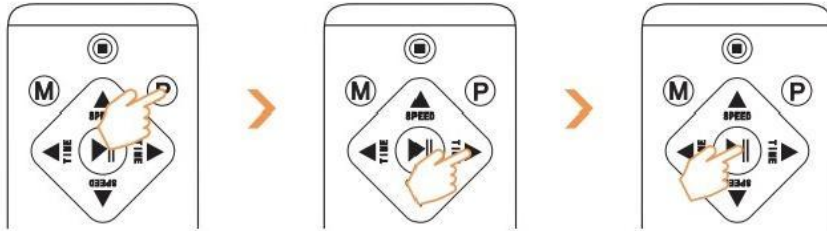

NOTE: Time Value set/10 segments=Running time of each segment

Program	Segment	Segment									
		1	2	3	4	5	6	7	8	9	10
P1	Speed	1	2	2	1	1	2	2	3	4	1
P2	Speed	1	2	1	2	1	2	3	4		2
P3	Speed		2		2	3	2	4	2	1	2
P4	Speed	2	1	2		2	3	3	1	2	
P5	Speed	2	1		2	2	1	2	3	2	2
P6	Speed	2	2		2	3	2	3	2	3	
P7	Speed	2		2	2		2		2	3	
P8	Speed		2	3	2	1	2	2		2	3
P9	Speed	2	2	4	2	4	2	2	3	2	1
P10	Speed	1	2	2	1	2	2	3	2	3	2
P11	Speed	2	3	4	4	3	3	2	3	3	1
P12	Speed	2	2	1	2	2	3	2	3	2	3

5.6 Sleep Mode

When the treadmill stops running and there is no operation for more than 10 minutes, the system will automatically turn off all displays and enter the sleep mode. Pressing any key will wake it up.

6. How to Use with APP

6.1 APP Download

Scan the QR Code or search the APP named "FITSHOW" in Google Play or APP Store ([Http://lifitshow.com/qr](http://lifitshow.com/qr))



Tips:
Jump to the APP Store to download and install to open the APP, allow permission based on the system prompt.

6.2 Connect & Control Device

- ① Open the FITSHOW App and agree to the Privacy Policy and Terms of Service.
- ② Log in the APP, please use the mobile number or email to register for new user
- ③ Fill in the basic user information like height for more accurate exercise program recommendations.
- ④ On the APP homepage, click the "Workout" tab then press the "Quick Start" button
- ⑤ Turn on Bluetooth on your phone to search for device "Acezoe S30"

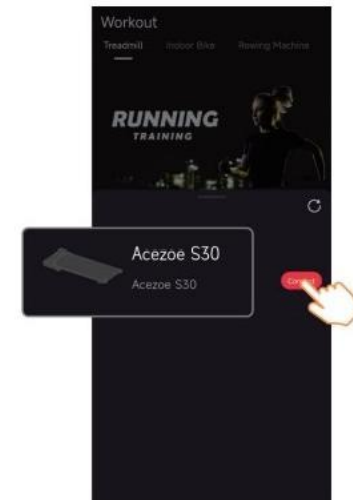
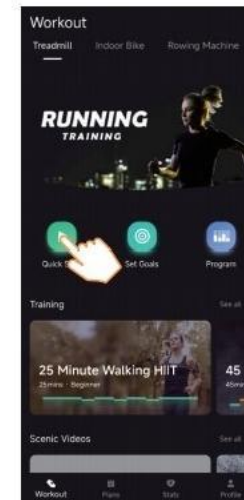

⑥ In the workout screen, swipe down for settings and swipe up for control.



⑦ Tap the screen to end the workout



6.3 Functions

Workout Mode

Quick Start	Workout with others in real time. Speed settings can be adjusted on demand.
Set Goals	Customize distance, time and calorie value as goal.
Program/ Training	Jump into workouts to explore new places from beautiful forest to breathtaking mountains.
Scenic Videos	It is recommended to watch some experts tips before exercising to make a suitable exercise plan.



Plans
Quick overview of exercise date.



Stats
Quick overview of daily activity data

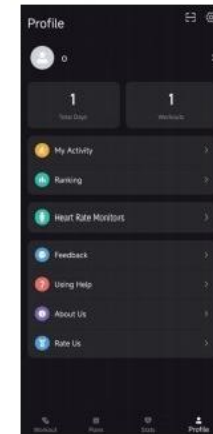

Profile
Quick overview of daily goals and activity data.

7.Storage

&Maintenance

7.1 Storage

① Turn the power switch of to the "O" position. Unplug the power cable.

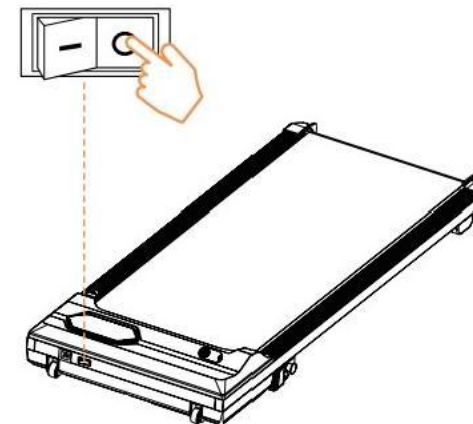

- ② Lift the back end of the treadmill and push the treadmill under the couch or bed with the help of the moving wheels.

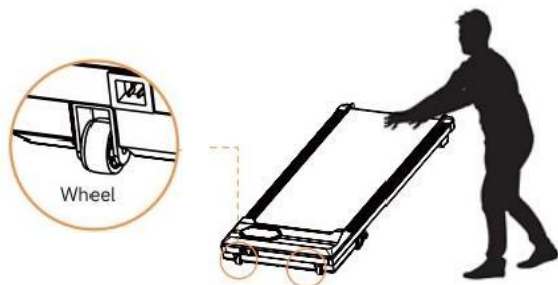

- ③ Lift the back end of the treadmill and push it to side of the wall with the help of the moving wheels, then lean it against the wall for storage.

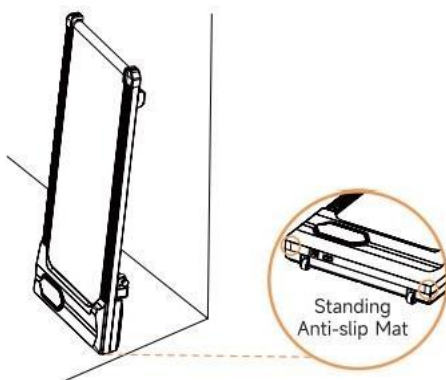

Note

To avoid the machine tipping over, the treadmill should be tilted against the wall with a certain angle, not completely vertical.

Remote Control Storage

The remote control of the S30 treadmill has a magnetic effect and can be attached to the mainframe for temporary storage when idle.

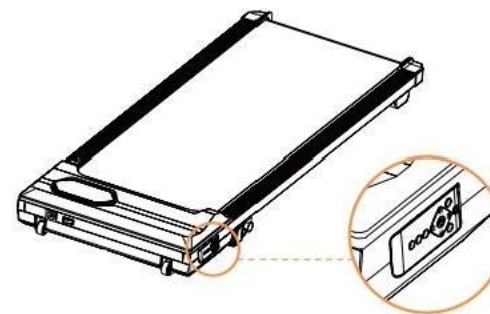

7.2 General Maintenance

Proper maintenance is helpful to prolong the service life of the treadmill

- Please place the treadmill in a dry and shady environment. Don't place the treadmill outdoors in direct sunlight.
- After 2 hours of continuous use, it is recommended to turn off the power and let the machine rest for 10 minutes, which will effectively protect the machine motor and prolong the life of the machine
- Make sure the shoes are clean when exercising, which avoid bringing foreign objects into the running belt to wear down the running desk/belt.
- Check and lock all parts of the treadmill regularly, and replace defective parts in time
- Don't use the treadmill by force when it is damaged to avoid product and personal damage. Contact Acezoe Support Team by email support01@acezoe.us, the after sales team will assist you.

7.3 Running Belt Adjustment

The running belt of treadmill is adjusted before leaving the factory, during transportation, it may be stretched or have deviated from the center position. Please let the running belt run by itself when using it for the first time, and observe whether the running belt is in the center position, and there is no pause or slippage

Adjust the Tightness of Running Belt

If the running belt slips or does not run smoothly in use, or there is a rattling noise from the running belt, adjust the tightness of the running belt to improve it.

- ① Insert the Allen key in the adjustment screw socket on the left side of the running belt, then turn the wrench clockwise to tighten the running belt. It's recommended to rotate 1/2 circle first;
- ② Repeat step 1 to adjust the right screw, same rotate 1/2 circle;
- ③ Repeat steps 1 and 2 until the running belt doesn't slip. Be sure in adjusting the screw to rotate the same distance;
- ④ If you need to loosen the running belt, please turn the key counterclockwise, and note that the left and right sides should rotate the same distance.

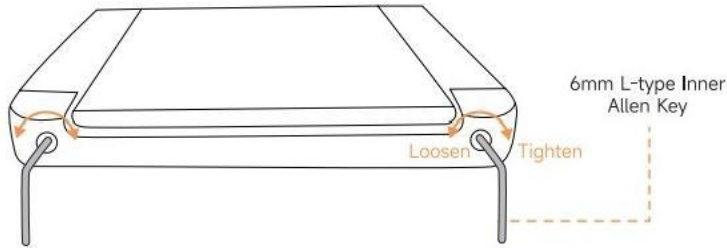

NOTE:

The running belt should not be adjusted too tightly, otherwise it will damage the running belt, which increases the pressure of the front/rear rotary drum, damages the drum bearing, produces noise and other problems.

Adjust the Position of Running Belt

When using the treadmill, because of the possible force difference exerted by both feet and the unbalanced pressure exerted on the running belt, the running belt may deviate from the center, but this deviation phenomenon is normal.

- ① Place the treadmill on a level surface.
- ② Let the treadmill run at a speed of about 2.2MPH.
- ③ If the running belt is to the left, use the allen key to turn the adjustment bolt on the left side 1/4 turn clockwise, then let the treadmill run for 30s, the running belt will return to center.
- ④ If the running belt is to the right, use the allen key to turn the right adjustment bolt 1/4 turn clockwise, then let the treadmill run for 30s, the running belt will return to center.

- ⑤ If the running belt is still not in the middle position, repeat the above operation until it is adjusted to the center position.

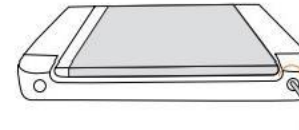

Running Belt Right to Center

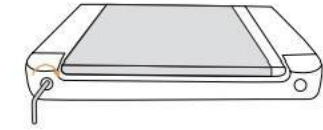

Running Belt Left to Center

NOTE

Do not over-tighten the rotary drum as this will cause permanent damage to the bearing.

7.4 Running Belt Lubrication

Adding lubricant Step

- ① Turn the treadmill to a low speed of 0.5MPH;
- ② Open the lid of the drip port and inject 10ml of lubricating oil;
- ③ Lightly step on the running belt on the front of the treadmill from left to right, then keep for about 8~10 minutes to make the silicone oil be completely absorbed by the running belt.

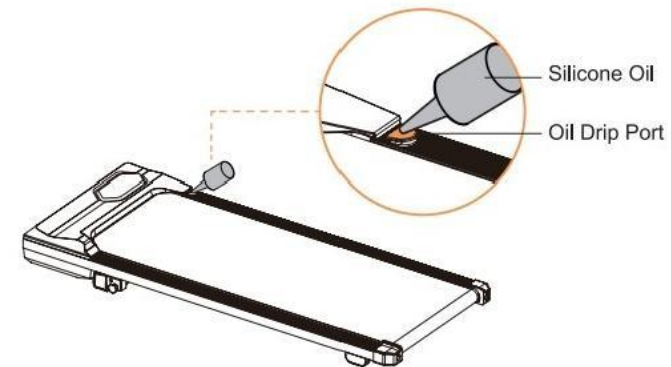

NOTE:

- Please use silicone oil not made of petroleum.
- Please do not over-lubricate to avoid insufficient friction between the running belt and the running platform.
- It's recommended to add lubricant regularly, 10ml every 3 months.

7.5 Remote Control Battery Replacement

Replace the battery by pushing the latch upward with your finger, then pulling out the battery slot to the right. It's recommended to use a CR2025 battery. (One complimentary battery is included in the package list)

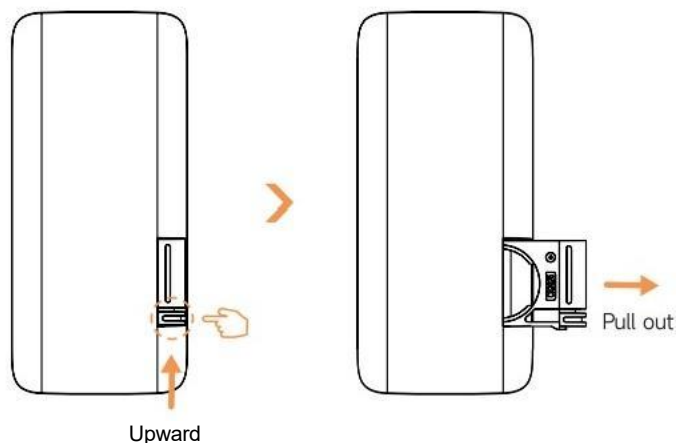

7.6 Product Cleaning

- After using the product each time, please wipe the stains off the motor cover, display, side strips and other parts with a clean cloth.
- If the product is used frequently, it can be wiped with a mild detergent
- Open the motor protection cover at least once a year, vacuum the motor, and clean the running belt and lubricating silicone oil once to avoid dust accumulation affecting machine performance.

NOTE:

- When cleaning the treadmill, the power switch should be turned off and the power cord should be removed from the socket.
- Please do not use corrosive detergent to wipe
- Please be careful not to splash water under the bluetooth speaker port and the running belt

8. Specification Parameters

Brand	Acezoe
Product	Under Desk Treadmill
Model	S30
Rated Voltage	110-240V~, 50/60Hz
Range of Speed	0.5-4.0 MPH 1-6KM/H
Running Area	15.35*39.4 inches 39*100cm
Product Size	44.1*19.3*4.5 inches 112*49*11.4 cm
Package Size	50.8*22.5*5.6 inches 129*57*14.3 cm
Maximum loading bearing	265 lbs 120kgs
Net Weight	17.2 kgs 37.9 lbs
Gross Weight	20.5 kgs 45.2 lbs
Control Method	Remote Control, App Control
Running Mode	Free Run, Countdown Mode, P01~P12 Program
Incline Mode	Yes
Usage	Indoor

Parameter Display and Setting Range

	Setting Range	Display Range	Mode Default Value	Program Default Value
Speed	0.5-4.0 MPH	0.0-4.0 MPH		
Time	5:00~99:00 Mins	0:00~99:99 Mins	30:00	30:00
Distance	1~99.0 MI	0~99.9 MI	1	
Calories	20~990 kcal	0~999 kcal	50	

9. Troubleshooting

Issue	Cause	Solution
No information is displayed on the screen	<ol style="list-style-type: none"> 1. The power is not connected 2. The switch is not turned on 3. Blown fuse on main control 4. Poor contact between main control and transformer 	<ol style="list-style-type: none"> 1. Connect the power cord correctly and turn on the power switch 2. Contact After-sales Team to replace the main control
Power failure during use	<ol style="list-style-type: none"> 1. The power is not connected 2. Motor failure 	<ol style="list-style-type: none"> 1. Check power cord is connected firmly 2. Contact After-sales Team
Running belt is not centered	<ol style="list-style-type: none"> 1. Uneven ground 2. Due to the unbalanced force on the left and right, the running belt deviates 	<ol style="list-style-type: none"> 1. Put the machine on a flat ground for use 2. Refer to the adjustment of running belt, use the Allen Key to adjust the running belt
Running belt stuck or slipped	Running belt too loose	Adjust the running belt to fit refer to the adjustment of running belt

Error Code

Code	Causes	Resolutions
E01	<ol style="list-style-type: none"> 1. Poor contact of the communication line of the touch console 2. No signal output from the touch console or main control 	Contact the after-sales team to rewire or replace the touch console
E02	<ol style="list-style-type: none"> 1. Loose motor cable or defective motor 2. The voltage between the motor and the main control is abnormal 	<ol style="list-style-type: none"> 1. Open the motor cover and check whether the wiring is firm 2. Contact the after-sales team to replace the motor or main control
E03	The main control detects abnormal speed, and the PMW drive circuit failed	Contact the after-sales team to replace the main control

E04	<ol style="list-style-type: none"> 1. The machine is overloaded, exceeding the rated voltage 2. Abnormal motor 3. Over-voltage function failure of main control 	<ol style="list-style-type: none"> 1. Use within the rated voltage range of 110-125V 2. Contact the after-sales team to replace the motor or main control
E05	<ol style="list-style-type: none"> 1. Motor over-current protection 2. Abnormal motor assembly 3. Failure of current limiting system of main control 	<ol style="list-style-type: none"> 1. Use within the rated operating current of 9.8A 2. Open the motor cover and check the abnormal assembly of the treadmill motor 3. Replace main control
E06	<ol style="list-style-type: none"> 1. The power supply voltage is too low 2. Poor contact of main control 	<ol style="list-style-type: none"> 1. Please check whether the power cord is normal 2. Contact the after-sales team to replace the main control



NOTE

If the problem in your treadmill is not included in the above, while you are not sure how to solve it, please contact us (Email: support01@acezoe.us) timely and do not handle it by yourself.

10. Warranty

The 2-Year Limited Warranty

- Your Acezoe machine has a 2-year warranty against original defects in material and workmanship, when used for private household purposes in accordance with the Acezoe Instruction Manual.
- This warranty provides parts necessary to ensure your machine is in proper operating condition during the warranty period for free.

WHAT IS COVERED?

- According to the requirements outlined in this instruction manual, subject to the following conditions and exclusions

- Only applies to purchases made from authorized retailers of Acezoe.
- This warranty will only be valid if the machine is used in the country in which it was sold.
- Any repair or replacement shall provide no new warranty coverage, but shall retain only the remaining portion of the original product's warranty. This warranty is offered only to the original purchaser and is not transferable. Proof of original purchase is required.

WHAT IS COVERED?

Acezoe shall not be liable for costs, damages or repairs incurred as a result of:

- Machines purchased from an unauthorized dealer.
- Careless operation or handling, misuse, abuse and/or lack of maintenance or use not in accordance with the Acezoe Instruction Manual.
- The machines are used for commercial or rental purposes in addition to normal domestic use.
- Use of parts not in accordance with the Acezoe Instruction Manual.
- Use of parts and accessories other than those produced or recommended by Acezoe.
- External factors unrelated to product quality and use, like accidental water damage
- Repairs or alterations carried out by unauthorized parties or agents.
- Damage caused by normal wear and tear, vandalism, accidents or by animals.
- Any act of Nature (such as fire, flooding, snow, ice, hurricanes, earthquakes, lightnings or other natural disasters), environmental conditions (such as air pollution, mold, mildew, etc.), or staining from foreign substances (such as dirt, grease, oil, etc.)
- Normal weathering due to exposure to sunlight, weather and atmosphere which can cause colored surfaces to among other things, flake, chalk, accumulate dirt or stains
- Improper operation, alteration, handling, storage, abuse or neglect of the products

HOW TO CLAIM?

Please keep your proof of purchase.

To make a claim under our Limited Warranty, or if there are any problems or malfunctions during use, or you still have any questions after reading this manual carefully, please feel free to contact us through email: support01@acezoe.us, we will try our best to provide you with a satisfactory solution.

You need to provide the following information:

1. Model
2. Order Number
3. Purchase Date
4. Description of Issues (Adding photos or videos would be helpful)

All work will be carried out by Acezoe or its authorized agency. Any replaced defective parts will become the property of Acezoe.

11. FCC Statement

FCC ID: 2A48I-JF-H-39K

FCC STATEMENT:

This device complies with part 15 of the FCC Rules. Operation is subject to the following two conditions: (1) This device may not cause harmful interference, and (2) this device must accept any interference received, including interference that may cause undesired operation.

Any Changes or modifications not expressly approved by the party responsible for compliance could void the user's authority to operate the equipment.

Note: This equipment has been tested and found to comply with the limits for a Class B digital device, pursuant to part 15 of the FCC Rules. These limits are designed to provide reasonable protection against harmful interference in a residential installation. This equipment generates uses and can radiate radio frequency energy and, if not installed and used in accordance with the instructions, may cause harmful interference to radio communications. However, there is no guarantee that interference will not occur in a particular installation. If this equipment does cause harmful interference to radio or television reception, which can be determined by turning the equipment off and on, the user is encouraged to try to correct the interference by one or more of the following measures:

-Reorient or relocate the receiving antenna.

-Increase the separation between the equipment and receiver.

-Connect the equipment into an outlet on a circuit different from that to which the receiver is connected.

-Consult the dealer or an experienced radio/TV technician for help.

The device has been evaluated to meet general RF exposure requirement. The device can be used in portable exposure condition without restriction.

12. Disposal

Correct Disposal of this product



This marking indicates that this product should not be disposed with other household wastes throughout the EU. To prevent possible harm to the environment or human health from uncontrolled waste disposal, recycle it responsibly to promote the sustainable reuse of material resources. To return your used device, please use the return and collection systems or contact the retailer where the product was purchased. They can take this product for environmental safe recycling.

13. Return & Warranty Process



① Scan the QR code on the left to activate the warranty of your order.



② Send the problem description to AcezoeTeam (support01@acezoe.us).



③ Acezoe Team provide the best solution includes troubleshooting replacement parts or new machine



④ UPS delivers the package to you or Amazon refunds you.

Contact US | ✉ support01@acezoe.us

Please feel free to contact us if you encounter any problem, we'll try our best to give you a satisfied solution.



Contact us -We will get back to you within 1 business day.



Scan for product installation and maintenance videos.

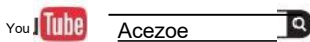

support01@acezoe.us  www.acezoe.us



IMPORTANT: Read all instructions carefully before using this product. Retain this owner's manual for future reference.

Please do not disassemble, repair or return the machine before contacting Acezoe Support Team.