

SPECIFICATION FOR APPROVAL

1. MECHANICAL DIMENSION (UNIT:mm)

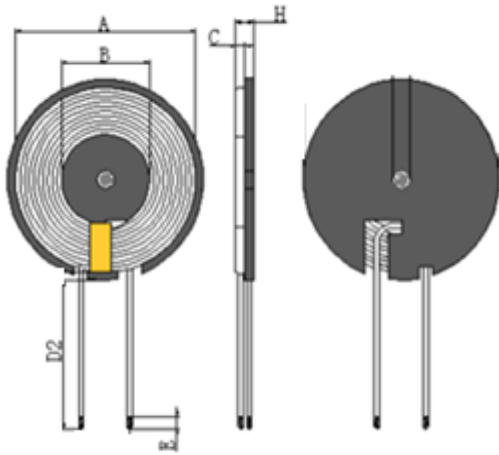

2. SCHEMATICS:

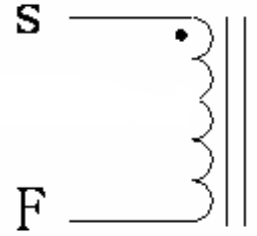

A	B	C	D2	E	H				
43.5±0.05mm	20.5±0.5mm	0.65±0.02mm	55±3mm	3±2mm	2.1mm MAX				

3. WINDING:

STEP	START-FINISH	WIRE TYPE	TURNS	TAPE	REMARK
N1	S-F	Hot air wire $\phi 0.08 \times 80$ 2UEW	10TS (Ref)		

4. ELECTRICAL SPECIFICATION:

ITEM	L	DCR			HI-POT
TEST	coil	S-F			
CON	100KHz, 0.25V	AT 25°C			
SPEC	6.5uH ± 10%	65mΩ Max			

5. BILF OF MATERIAL:

NO.	ITEM	MATERIAL SPECIFICATION	MANUFACTURER	SGS NO.
1	Hot air wire 0.08×80	Hot air wire 0.08×80	NANJINGJINNINGCO,LTD	
2	Lead-free tin strip	Lead-free tin strip	QIAODO	
3	glue	Yellow gum 9999	LIANCHENG CO.,LTD	
4	High temperature adhesive paper	8mm High temperature adhesive paper	CUDAK CO.,LTD	
5	Back glue	$\phi 41.8 \times 0.1$ mm	CUDAK CO.,LTD	
6				