RF Exposure Report

Report No.: AGC11758240712FH01

FCC ID : 2A482-PPCXM05G2

APPLICATION PURPOSE : Original Equipment

PRODUCT DESIGNATION : Power Bank

BRAND NAME : baseus

MODEL NAME : PPCXM05

APPLICANT : Shenzhen Baseus Technology Co., Ltd.

DATE OF ISSUE : Jul. 26, 2024

STANDARD(S) : KDB680106 D01 RF Exposure Wireless Charging Base App v04

REPORT VERSION : V1.0

Attestation of Global Compliance (Shenzhen) Co., Ltd



Any report having not been signed by authorized approver, or having been altered without authorization, or having not been stamped by the "Dedicated Testing/Inspection Stamp" is deemed to be invalid. Copying or excerpting portion of, or altering the content of the report is not permitted without the written authorization of AGC. The test results presented in the report apply only to the tested sample. Any objections to report issued by AGC should be submitted to AGC within 15days after the issuance of the test report. Further enquiry of validity or verification of the test report should be addressed to AGC by agc01@agccert.com.

Attestation of Global Compliance(Shenzhen)Co., Ltd
Attestation of Global Compliance(Shenzhen)Std & Tech Co., Ltd
Tel: +86-755 2523 4088 E-mail: agc@agccert.com Web: <http://www.agccert.com/>



Report Revise Record

Report Version	Revise Time	Issued Date	Valid Version	Notes
V1.0	/	Jul. 26, 2024	Valid	Initial Release

Any report having not been signed by authorized approver, or having been altered without authorization, or having not been stamped by the "Dedicated Testing/Inspection Stamp" is deemed to be invalid. Copying or excerpting portion of, or altering the content of the report is not permitted without the written authorization of AGC. The test results presented in the report apply only to the tested sample. Any objections to report issued by AGC should be submitted to AGC within 15days after the issuance of the test report. Further enquiry of validity or verification of the test report should be addressed to AGC by agc01@agccert.com.

Table of Contents

1. General Information	4
2. Product Information	5
2.1 Product Technical Description	5
3. Test Environment.....	6
3.1 Address of The Test Laboratory	6
3.2 Test Facility	6
3.3 Environmental Conditions	7
3.4 Measurement Uncertainty.....	7
3.5 List of Equipment Used.....	7
4. Equipment Used in Tested System	8
5. Description of Test Modes.....	8
6. RF Exposure Measurement	9
6.1 Refer Evaluation Method	9
6.2 Measurement Limits.....	9
6.3 Measurement Setup.....	10
6.4 Measurement Procedure	11
6.5 Measurement Results	13
Appendix I: Photographs of Test Setup.....	15

Any report having not been signed by authorized approver, or having been altered without authorization, or having not been stamped by the “Dedicated Testing/Inspection Stamp” is deemed to be invalid. Copying or excerpting portion of, or altering the content of the report is not permitted without the written authorization of AGC. The test results presented in the report apply only to the tested sample. Any objections to report issued by AGC should be submitted to AGC within 15days after the issuance of the test report. Further enquiry of validity or verification of the test report should be addressed to AGC by agc01@agccert.com.

1. General Information

Applicant	Shenzhen Baseus Technology Co., Ltd.
Address	2nd Floor, Building B, Baseus Intelligence Park, No.2008, Xuegang Rd, Gangtou Community, Bantian Street, Longgang District, Shenzhen, China
Manufacturer	Shenzhen Baseus Technology Co., Ltd.
Address	2nd Floor, Building B, Baseus Intelligence Park, No.2008, Xuegang Rd, Gangtou Community, Bantian Street, Longgang District, Shenzhen, China
Factory	Shenzhen Firstar Battery Co., Limited
Address	1st ~ 2nd floor of Building 3, Room 201 of Building 6, 1st, 2nd, 3rd, 4th floor Room 101 of Building 2, Fuzhong Industrial Park, Huaide Community, Fuyong Street, Bao'an District, Shenzhen, Guangdong, P.R. China
Product Designation	Power Bank
Brand Name	baseus
Test Model	PPCXM05
Series Model(s)	N/A
Difference Description	N/A
Date of receipt of test item	Jul. 12, 2024
Date of Test	Jul. 12, 2024 to Jul. 26, 2024
Deviation from Standard	No any deviation from the test method
Condition of Test Sample	Normal
Test Result	Pass
Test Report Form No	AGCER-FCC-RF Exposure (WPT_MPE)-V1

Note: The test results of this report relate only to the tested sample identified in this report.

Prepared By 

 Jack Gui
 (Project Engineer) Jul. 26, 2024

Reviewed By 

 Calvin Liu
 (Reviewer) Jul. 26, 2024

Approved By 

 Max Zhang
 (Authorized Officer) Jul. 26, 2024

Any report having not been signed by authorized approver, or having been altered without authorization, or having not been stamped by the "Dedicated Testing/Inspection Stamp" is deemed to be invalid. Copying or excerpting portion of, or altering the content of the report is not permitted without the written authorization of AGC. The test results presented in the report apply only to the tested sample. Any objections to report issued by AGC should be submitted to AGC within 15days after the issuance of the test report. Further enquiry of validity or verification of the test report should be addressed to AGC by agc01@agccert.com.

2. Product Information

2.1 Product Technical Description

Equipment Specification	WPT
Operation Frequency	115kHz-205kHz
Hardware Version	REV.B
Software Version	v1.0
Modulation Type	ASK
Field Strength of Fundamental	64.47dBuV/m@3m (Max)
Antenna Designation	Coil Antenna
EUT Input Rating	Type-C Input: DC5V/2.4A
EUT Output Rating	Type-C Output: DC5V/2.4A;DC9V/2.22A;DC12V/1.5A Total Output: DC5V/2.4A
Wireless Charging Output Power	5W/7.5W/10W/15W
Adapter Information	N/A

Any report having not been signed by authorized approver, or having been altered without authorization, or having not been stamped by the "Dedicated Testing/Inspection Stamp" is deemed to be invalid. Copying or excerpting portion of, or altering the content of the report is not permitted without the written authorization of AGC. The test results presented in the report apply only to the tested sample. Any objections to report issued by AGC should be submitted to AGC within 15days after the issuance of the test report. Further enquiry of validity or verification of the test report should be addressed to AGC by agc01@agccert.com.

3. Test Environment

3.1 Address of The Test Laboratory

Laboratory: Attestation of Global Compliance (Shenzhen) Co., Ltd.

Address: 1-2/F, Building 19, Junfeng Industrial Park, Chongqing Road, Heping Community, Fuhai Street, Bao'an District, Shenzhen, Guangdong, China

3.2 Test Facility

The test facility is recognized, certified, or accredited by the following organizations:

CNAS-Lab Code: L5488

Attestation of Global Compliance (Shenzhen) Co., Ltd. has been assessed and proved to FOLLOW CNAS-CL01 Accreditation Criteria for Testing and Calibration Laboratories (identical to ISO/IEC17025: 2017 General Requirements for the Competence of Testing and Calibration Laboratories.)

A2LA-Lab Cert. No.: 5054.02

Attestation of Global Compliance (Shenzhen) Co., Ltd. EMC Laboratory has been accredited by A2LA for technical competence in the field of electrical testing, and proved to follow ISO/IEC 17025: 2017 General Requirements for the Competence of Testing and Calibration Laboratories and any additional program requirements in the identified field of testing.

FCC-Registration No.: 975832

Attestation of Global Compliance (Shenzhen) Co., Ltd. EMC Laboratory has been registered and fully described in a report filed with the FCC (Federal Communications Commission). The acceptance letter from the FCC is maintained in our files with Registration 975832.

IC-Registration No.: 24842 (CAB identifier: CN0063)

Attestation of Global Compliance (Shenzhen) Co., Ltd. EMC Laboratory has been registered and fully described in a report filed with the Certification and Engineering Bureau of Industry Canada. The acceptance letter from the IC is maintained in our files with Registration 24842.

Any report having not been signed by authorized approver, or having been altered without authorization, or having not been stamped by the "Dedicated Testing/Inspection Stamp" is deemed to be invalid. Copying or excerpting portion of, or altering the content of the report is not permitted without the written authorization of AGC. The test results presented in the report apply only to the tested sample. Any objections to report issued by AGC should be submitted to AGC within 15days after the issuance of the test report. Further enquiry of validity or verification of the test report should be addressed to AGC by agc01@agccert.com.

3.3 Environmental Conditions

	Normal Conditions
Temperature range (°C)	15 - 35
Relative humidity range	20% - 75%
Pressure range (kPa)	86 - 106
Power supply	--

3.4 Measurement Uncertainty

The reported uncertainty of measurement $y \pm U$, where expanded uncertainty U is based on a standard uncertainty multiplied by a coverage factor of $k=2$, providing a level of confidence of approximately 95%.

Item	Measurement Uncertainty
E-Field Strength(0.003-0.4MHz)	$\pm 1.5\text{dB}$
E-Field Strength(0.4-10MHz)	$\pm 1.3\text{dB}$
H-Field Strength(0.003-0.4MHz)	$\pm 1.3\text{dB}$
H-Field Strength(0.4-10MHz)	$\pm 1.2\text{dB}$

3.5 List of Equipment Used

Used	Equipment No.	Test Equipment	Manufacturer	Model No.	Serial No.	Last Cal. Date (YY-MM-DD)	Next Cal. Date (YY-MM-DD)
<input checked="" type="checkbox"/>	AGC-RF-011	Broadband Field Meter	WAVECONTROL	SMP2	19SN1101	2023-02-24	2025-02-23
<input checked="" type="checkbox"/>	AGC-RF-012	Probe FHP	WAVECONTROL	WP400	19WP100558	2023-02-24	2025-02-23

Any report having not been signed by authorized approver, or having been altered without authorization, or having not been stamped by the "Dedicated Testing/Inspection Stamp" is deemed to be invalid. Copying or excerpting portion of, or altering the content of the report is not permitted without the written authorization of AGC. The test results presented in the report apply only to the tested sample. Any objections to report issued by AGC should be submitted to AGC within 15days after the issuance of the test report. Further enquiry of validity or verification of the test report should be addressed to AGC by agc01@agccert.com.

4. Equipment Used in Tested System

The following peripheral devices and interface cables were connected during the measurement:

Test Accessories Come From The Laboratory

No.	Equipment	Model No.	Manufacturer	Specification Information	Cable
1	Wireless Charging Load	--	HUAWEI	Support 5W,7.5W,10W,15W	--
2	Adapter	HW-200440C00	HUAWEI	Input(AC):100V-240V 50/60Hz 2.4A Output(DC):USB-C(5V/3A;9V/3A;10V/4A;11V/6A;12V/3A;15V/3A;20V/4.4A) USB-A(5V/2A;10V/4A;11V/6A;20V/4.4A)	--

Test Accessories Come From The Manufacturer

No.	Equipment	Model No.	Manufacturer	Specification Information	Cable
1	USB Cable	--	--	--	0.35m unshielded

5. Description of Test Modes

NO.	Test Mode Description	Exposure Conditions
1	AC/DC Adapter Input DC5V 2.4A + EUT + Wireless load (5W)	Mobile
2	AC/DC Adapter Input DC5V 2.4A + EUT + Wireless load (2.5W)	Mobile
3	AC/DC Adapter Input DC5V 2.4A + EUT + Wireless load (0W)	Mobile
4	EUT + Wireless load (15W)	Portable
5	EUT + Wireless load (7.5W)	Portable
6	EUT + Wireless load (0W)	Portable

Note: All test modes were pre-tested, but we only recorded the worst case in this report.

6. RF Exposure Measurement

6.1 Refer Evaluation Method

ANSI C95.1–1999: IEEE Standard for Safety Levels with Respect to Human Exposure to Radio Frequency Electromagnetic Fields, 3 kHz to 300 GHz.
 FCC KDB publication KDB680106 D01 RF Exposure Wireless Charging Apps v04: RF Exposure Considerations for Low Power Consumer Wireless Power Transfer Applications
 FCC CFR 47 part1 1.1310: Radiofrequency radiation exposure limits.
 FCC CFR 47 part2 2.1091: Radiofrequency radiation exposure evaluation: mobile devices.
 FCC CFR 47 part 18.107: Industrial, Scientific, and Medical Equipment.

6.2 Measurement Limits

Limits for Maximum Permissible Exposure (MPE)/Controlled Exposure

Frequency Range(MHz)	Electric Field Strength(V/m)	Magnetic Field Strength(A/m)	Power Density (mW/cm ²)	Averaging Time (minute)
Limits for Occupational/Controlled Exposure				
0.3-3.0	614	1.63	*100	6
3.0-30	1842/f	4.89/f	*900/f ²	6
30-300	61.4	0.163	1.0	6
300-1,500	/	/	f/300	6
1,500-100,000	/	/	5	6

Limits for Maximum Permissible Exposure (MPE)/Uncontrolled Exposure

Frequency Range(MHz)	Electric Field Strength(V/m)	Magnetic Field Strength(A/m)	Power Density (mW/cm ²)	Averaging Time (minute)
Limits for General Population/Uncontrolled Exposure				
0.3-1.34	614	1.63	*100	30
1.34-30	824/f	2.19/f	*180/f ²	30
30-300	27.5	0.073	0.2	30
300-1,500	/	/	f/1500	30
1,500-100,000	/	/	1.0	30

F=frequency in MHz

*=Plane-wave equivalent power density

According to FCC KDB 680106 D01v04 Section 3. RF Exposure Requirements clause 3.2 the Emission-Limits in the frequency range from 100 kHz to 300 kHz should be assessed versus the limits at 300 kHz in Table 1 of CFR 47 – Section 1.1310 as following:

Frequency	E-Field V/m	*/* A/m	B-Field uT
0.3 MHz – 3.0 MHz	614	1.613	2.0
3.0 MHz – 30 MHz	824/f (=27.5 _{30MHz})	2.19/f (=0.073 _{30MHz})	--

A KDB inquire was required to determine/confirm the applicable limits below 100kHz.

Any report having not been signed by authorized approver, or having been altered without authorization, or having not been stamped by the “Dedicated Testing/Inspection Stamp” is deemed to be invalid. Copying or excerpting portion of, or altering the content of the report is not permitted without the written authorization of AGC. The test results presented in the report apply only to the tested sample. Any objections to report issued by AGC should be submitted to AGC within 15days after the issuance of the test report. Further enquiry of validity or verification of the test report should be addressed to AGC by agc01@agccert.com.

6.3 Measurement Setup

Mobile:

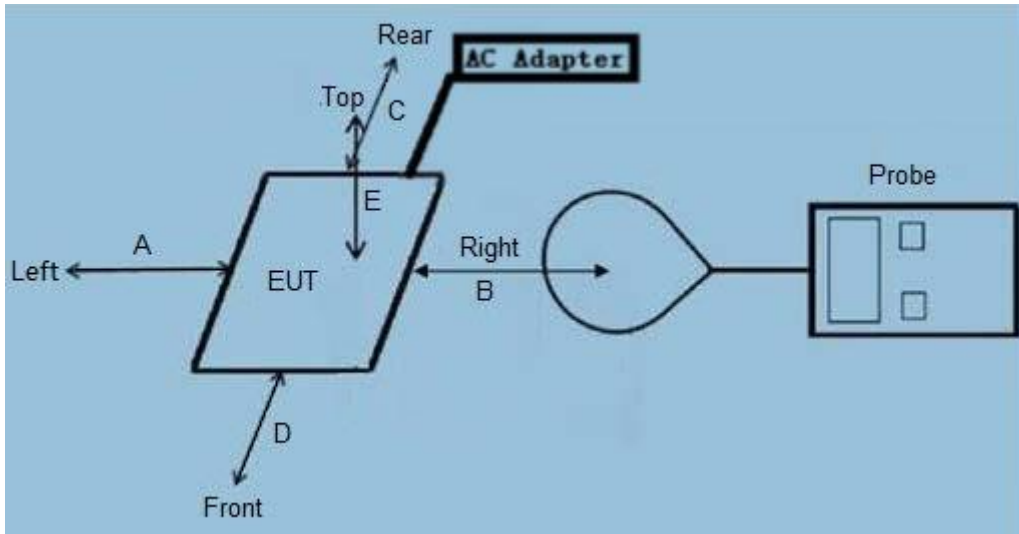

Portable:

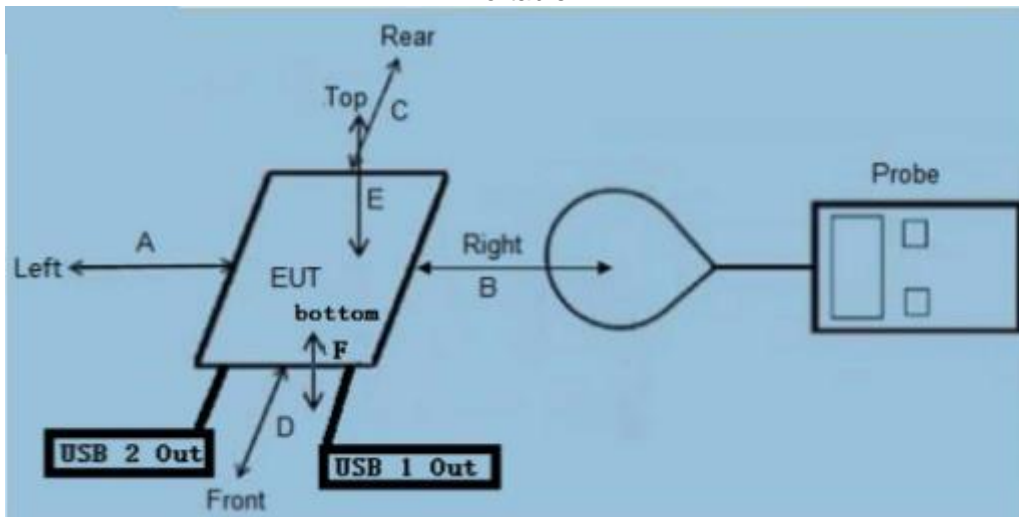

Note:

- RF exposure assessment tests are conducted in a shielded room.
- Refer to the following test method description for the test distance between the edge of the charger and the measuring probe.
- As shown in the above picture, the test layout is not for the real object, only the requirements of the test layout listed in the standard requirements are presented, for reference only.
- The actual test EUT distinguishes the test type according to the requirements as shown in the figure above.

Any report having not been signed by authorized approver, or having been altered without authorization, or having not been stamped by the "Dedicated Testing/Inspection Stamp" is deemed to be invalid. Copying or excerpting portion of, or altering the content of the report is not permitted without the written authorization of AGC. The test results presented in the report apply only to the tested sample. Any objections to report issued by AGC should be submitted to AGC within 15days after the issuance of the test report. Further enquiry of validity or verification of the test report should be addressed to AGC by agc01@agccert.com.

6.4 Measurement Procedure

6.4.1 For mobile RF exposure:

- a) The RF exposure test was performed on 360 degree turn table in anechoic chamber.
- b) E-field and H-field measurements should be taken with the probe geometric center located 20cm around the EUT and 20cm above the top surface of the master/client pair.
- c) The highest emission level was recorded and compared with limit as soon as measurement of each point (A, B, C, D, E) were completed.
- d) The EUT were measured according to the dictates of KDB 680106 D01v04

Equipment Approval Considerations of KDB 680106 D01v04

Requirements of KDB 680106	Yes or No	Description
The power transfer frequency is below 1 MHz	Yes	The device operate in the frequency range 115kHz-205kHz.
Output power from each primary coil is less than 15 watts	Yes	The maximum output power of the primary coil is 15W.
The transfer system includes only single primary and secondary coils. This includes charging systems that may have multiple primary coils and clients that are able to detect and allow coupling only between individual pairs of coils.	Yes	The transfer system includes single coil that is able to detect receiver device.
Client device is placed directly in contact with the transmitter.	Yes	Client device is placed directly in contact with the transmitter.
Mobile exposure conditions only (portable exposure conditions are not covered by this exclusion).	NO	Device can be used in portable conditions.
The aggregate H-field strengths at 20 cm surrounding the device and 20 cm above the top surface from all simultaneous transmitting coils are demonstrated to be less than 50% of the MPE limit.	Yes	The EUT H-field strengths at 15 cm surrounding the device and 20 cm above the top surface from all simultaneous transmitting coils are demonstrated to be less than 50% of the MPE limit.
For systems with more than one radiating structure, the conditions specified in (5) must be met when the system is fully loaded (i.e., clients absorbing maximum power available), and with all the radiating structures operating at maximum power at the same time, as per design conditions. If the design allows one or more radiating structures to be powered at a higher level while other radiating structures are not powered, then those cases must be tested as well. For instance, a device may use three RF coils powered at 5 W, or one coil powered at 15 W: in this case, both scenarios shall be tested.	Yes	The device has only a single radiating structure and is tested at full load

Any report having not been signed by authorized approver, or having been altered without authorization, or having not been stamped by the "Dedicated Testing/Inspection Stamp" is deemed to be invalid. Copying or excerpting portion of, or altering the content of the report is not permitted without the written authorization of AGC. The test results presented in the report apply only to the tested sample. Any objections to report issued by AGC should be submitted to AGC within 15 days after the issuance of the test report. Further enquiry of validity or verification of the test report should be addressed to AGC by agc01@agccert.com.

6.4.2 For portable RF exposure:

- The RF exposure test was performed on 360 degree turn table in anechoic chamber.
- The measurement probe was placed at test distance (from 0 cm to 20 cm, in 2 cm maximum increment) which is between the edge of the charger and the geometric center of probe.
- The highest emission level was recorded and compared with limit as soon as measurement of each point (A, B, C, D, E, F,) were completed.
- The EUT were measured according to the dictates of KDB 680106 D01v04

Specific Assessment Methods:

- Test performed with all the radiating structures operating at maximum power at the same time.
- H-field measurements are taken along all three axes the device from 0cm~20cm in 2cm minimum increment for each edge surface of the host/client pair. **If the center of the probe sensing element is more than 5mm from the probe outer edge, the field strengths need to be estimated for the positions that are not reachable.**
- According to Calibration information and specification about WP400 Probe, The Probe WP400 Probe's sensitive elements center is located in the probe's center, and the distance from the sensitive elements center to the tip of probe is 5.5cm.
- For locations that cannot be reached by numerical calculations, the actual field strengths of 0 cm, 2 cm, and 4 cm need to be estimated.
- Use **Biot-Savart Law formula** theory to estimate the strength of the magnetic field that the measuring instrument cannot measure. According to Biot-Savart Law formula:

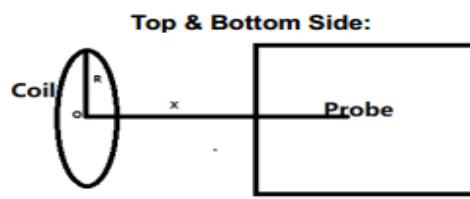

$$B = \frac{\mu_0 * I * N * R^2}{2 * (R^2 + x^2)^{3/2}}$$

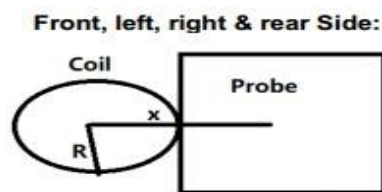

$$B = \frac{\mu_0 * I * N}{2 * x}$$

- **B (Unit: A/m):** means H-field value;
- **μ_0** is space permeability; $\mu_0=4\pi*10^{-7}$;
- **I(Unit: A):** A current element passing through a radiated coil;
- **R(Unit: m):** means the Radius of radiated coil, According to provided Antenna specification:
 $R=40/2=20\text{mm}=0.002\text{m}$;
- **Test Distance(Unit: m):** The distance from the sensing element of the probe to the edge of the device surface.
- **x (Unit: m):** means the center of the coil to the sensing elements of the probe. (For top & bottom side: $x=\text{test distance}$; For other side: $x=\text{test distance}+R$)
- **N:** Number of turns, according to providing "Antenna specification" files: $N=10$.
- For validation purposes: If the value to show a 30% agreement between the mode and the probe measurements for the two closest points to the device surface, and with 2cm increments. Then this **extrapolation method is reasonable.**

Any report having not been signed by authorized approver, or having not been stamped by the "Dedicated Testing/Inspection Stamp" is deemed to be invalid. Copying or excerpting portion of, or altering the content of the report is not permitted without the written authorization of AGC. The test results presented in the report apply only to the tested sample. Any objections to report issued by AGC should be submitted to AGC within 15days after the issuance of the test report. Further enquiry of validity or verification of the test report should be addressed to AGC by agc01@agccert.com.

6.5 Measurement Results

Mobile devices are evaluated as follows:

Operate Mode	Field Strength	Measured H-Field Strength Values (A/m) Measured E-Field Strength Values (V/m)					FCC Limit	50%_FCC limit
		Position A	Position B	Position C	Position D	Position E		
Mode 1	nT	263.82	226.13	276.38	213.57	301.51	--	--
Mode 1	A/m	0.21	0.18	0.22	0.17	0.24	1.63	0.815
Mode 1	V/m	0.641	0.658	0.747	0.716	0.739	614	307

Note: Unit conversion formula: 1A/m =1250*nT

Portable devices are evaluated as follows:

Validation results for the numerical calculation model

- 1) Measure with probe directed contact (test distace:5.5cm)
- 2) Using Biot-Savart formula to calculate estimated results at test distance of 6cm,8cm and 10 cm;
- 3) measure at test distance of 8 cm and 10cm;
- 4) Compares the estimated results and measured result, the variation should not be greater than 30%

Distance(cm)	Test condition: Mode 4(Worst)																	
	Position A			Position B			Position C			Position D			Position E			Position F		
	Mea.	Est.	Var.	Mea.	Est.	Var.	Mea.	Est.	Var.	Mea.	Est.	Var.	Mea.	Est.	Var.	Mea.	Est.	Var.
5.5	0.0518	/	/	0.0375	/	/	0.0124	/	/	0.0975	/	/	0.0832	/	/	0.0009	/	/
6	0.0465	0.0432	7.1	0.0314	0.0308	1.9	0.0114	0.0110	3.5	0.0942	0.0930	1.2	0.0814	0.0808	0.7	0.0006	0.0005	16.7
8	0.0218	0.0212	2.7	0.0183	0.177	3.2	0.0077	0.008	3.9	0.0061	0.0067	9.8	0.0061	0.006	1.6	0.0018	0.0014	22.2
10	0.0103	0.0112	8.7	0.0091	0.0082	0.98	0.0058	0.0067	15.0	0.0049	0.0056	14.2	0.0049	0.005	2.0	0.0016	0.0013	18.7

Mea.: Measured H-field(A/m)
Est.: Estimated H-field(A/m)
Var.: Variation between measured and estimated value (%)

Conclusion: The numerical calculation model is valid.

Any report having not been signed by authorized approver, or having been altered without authorization, or having not been stamped by the "Dedicated Testing/Inspection Stamp" is deemed to be invalid. Copying or excerpting portion of, or altering the content of the report is not permitted without the written authorization of AGC. The test results presented in the report apply only to the tested sample. Any objections to report issued by AGC should be submitted to AGC within 15days after the issuance of the test report. Further enquiry of validity or verification of the test report should be addressed to AGC by agc01@agccert.com.

Final H-Field Emission level with a combination of measured and estimated results.

Distance(cm)	Test condition: Mode 4(Worst)							
	Type	Measured H-Field Strength Values (A/m)						Limit(A/m)
		Position A	Position B	Position C	Position D	Position E	Position F	
0	Estimate	1.2881	1.0362	0.0341	0.0332	0.0274	0.0041	1.63
2	Estimate	0.4892	0.3941	0.0187	0.0162	0.0153	0.0007	1.63
4	Estimate	0.1278	0.1052	0.0141	0.0118	0.0074	0.0006	1.63
6	Estimate	0.0451	0.0366	0.0125	0.0072	0.0063	0.0005	1.63
8	Measured	0.0212	0.0175	0.0062	0.0052	0.0047	0.0004	1.63
10	Measured	0.0100	0.0088	0.0065	0.0043	0.0037	0.0004	1.63
12	Measured	0.0068	0.0059	0.0052	0.0048	0.0032	0.0003	1.63
14	Measured	0.0051	0.0044	0.0040	0.0038	0.0032	0.0002	1.63
16	Measured	0.0028	0.0022	0.0045	0.0037	0.0029	0.0002	1.63
18	Measured	0.0023	0.0017	0.0026	0.0022	0.0031	0.0002	1.63
20	Measured	0.0019	0.0010	0.0035	0.0024	0.0019	0.0002	1.63

Any report having not been signed by authorized approver, or having been altered without authorization, or having not been stamped by the "Dedicated Testing/Inspection Stamp" is deemed to be invalid. Copying or excerpting portion of, or altering the content of the report is not permitted without the written authorization of AGC. The test results presented in the report apply only to the tested sample. Any objections to report issued by AGC should be submitted to AGC within 15days after the issuance of the test report. Further enquiry of validity or verification of the test report should be addressed to AGC by agc01@agccert.com.

Appendix I: Photographs of Test Setup

Refer to the Report No.: AGC11758240712AP03

-----End of Report-----

Any report having not been signed by authorized approver, or having been altered without authorization, or having not been stamped by the "Dedicated Testing/Inspection Stamp" is deemed to be invalid. Copying or excerpting portion of, or altering the content of the report is not permitted without the written authorization of AGC. The test results presented in the report apply only to the tested sample. Any objections to report issued by AGC should be submitted to AGC within 15days after the issuance of the test report. Further enquiry of validity or verification of the test report should be addressed to AGC by agc01@agccert.com.

Attestation of Global Compliance(Shenzhen)Co., Ltd

Attestation of Global Compliance(Shenzhen)Std & Tech Co., Ltd

Tel: +86-755 2523 4088 E-mail: agc@agccert.com Web: <http://www.agccert.com/>



Conditions of Issuance of Test Reports

1. All samples and goods are accepted by the Attestation of Global Compliance (Shenzhen) Co., Ltd (the “Company”) solely for testing and reporting in accordance with the following terms and conditions. The company provides its services on the basis that such terms and conditions constitute express agreement between the company and any person, firm or company requesting its services (the “Clients”).
2. Any report issued by Company as a result of this application for testing services (the “Report”) shall be issued in confidence to the Clients and the Report will be strictly treated as such by the Company. It may not be reproduced either in its entirety or in part and it may not be used for advertising or other unauthorized purposes without the written consent of the Company. The Clients to whom the Report is issued may, however, show or send it, or a certified copy thereof prepared by the Company to its customer, supplier or other persons directly concerned. The Company will not, without the consent of the Clients, enter into any discussion or correspondence with any third party concerning the contents of the Report, unless required by the relevant governmental authorities, laws or court orders.
3. The Company shall not be called or be liable to be called to give evidence or testimony on the Report in a court of law without its prior written consent, unless required by the relevant governmental authorities, laws or court orders.
4. In the event of the improper use of the report as determined by the Company, the Company reserves the right to withdraw it, and to adopt any other additional remedies which may be appropriate.
5. Samples submitted for testing are accepted on the understanding that the Report issued cannot form the basis of, or be the instrument for, any legal action against the Company.
6. The Company will not be liable for or accept responsibility for any loss or damage however arising from the use of information contained in any of its Reports or in any communication whatsoever about its said tests or investigations.
7. Clients wishing to use the Report in court proceedings or arbitration shall inform the Company to that effect prior to submitting the sample for testing.
8. The Company is not responsible for recalling the electronic version of the original report when any revision is made to them. The Client assumes the responsibility to providing the revised version to any interested party who uses them.
9. Subject to the variable length of retention time for test data and report stored hereinto as otherwise specifically required by individual accreditation authorities, the Company will only keep the supporting test data and information of the test report for a period of six years. The data and information will be disposed of after the aforementioned retention period has elapsed. Under no circumstances shall we provide any data and information which has been disposed of after retention period. Under no circumstances shall we be liable for damage of any kind, including (but not limited to) compensatory damages, lost profits, lost data, or any form of special, incidental, indirect, consequential or punitive damages of any kind, whether based on breach of contract of warranty, tort (including negligence), product liability or otherwise, even if we are informed in advance of the possibility of such damages.

Any report having not been signed by authorized approver, or having been altered without authorization, or having not been stamped by the “Dedicated Testing/Inspection Stamp” is deemed to be invalid. Copying or excerpting portion of, or altering the content of the report is not permitted without the written authorization of AGC. The test results presented in the report apply only to the tested sample. Any objections to report issued by AGC should be submitted to AGC within 15days after the issuance of the test report. Further enquiry of validity or verification of the test report should be addressed to AGC by agc01@agccert.com.