

# FCC TEST REPORT

## FCC ID:2A477-FD05

**Report Number**..... : ZKT-220222L0960

Date of Test..... Feb. 17, 2022 to Feb. 29, 2022

Date of issue ..... : Feb. 29, 2022

Total number of pages ..... : 23

Test Result ..... : PASS

**Testing Laboratory**..... : **Shenzhen ZKT Technology Co., Ltd.**

Address ..... : 1/F, No. 101, Building B, No. 6, Tangwei Community Industrial Avenue, Fuhai Street, Bao'an District, Shenzhen, China

**Applicant's name** ..... : **Shenzhen Xuanfeng Innovations Technology Co., Ltd.**

Address ..... : C1513 Chuangxin Plaza, No. 2007, Pingshandadao, Pingshan District, Shenzhen

**Manufacturer's name** ..... : **Shenzhen Xuanfeng Innovations Technology Co., Ltd.**

Address ..... : C1513 Chuangxin Plaza, No. 2007, Pingshandadao, Pingshan District, Shenzhen

**Test specification:**

Standard..... : FCC CFR Title 47 Part 15 Subpart C

Test procedure..... : /

Non-standard test method ..... : N/A

**Test Report Form No.** ..... : TRF-EL-107\_V0

**Test Report Form(s) Originator** .... : ZKT Testing

**Master TRF** ..... : Dated: 2020-01-06

This device described above has been tested by ZKT, and the test results show that the equipment under test (EUT) is in compliance with the FCC requirements. And it is applicable only to the tested sample identified in the report.

This report shall not be reproduced except in full, without the written approval of ZKT, this document may be altered or revised by ZKT, personal only, and shall be noted in the revision of the document.

**Product name** ..... : 3 in1 wireless charger

Trademark ..... : /

Model/Type reference ..... : FD05

Ratings..... :  
Input:5V 3A /9V 2A  
Output1: 5W/7.5W/10W  
Output2: 5W  
Output1: 2.5W

**Testing procedure and testing location:**

**Testing Laboratory** ..... : **Shenzhen ZKT Technology Co., Ltd.**

**Address** ..... : 1/F, No. 101, Building B, No. 6, Tangwei Community  
Industrial Avenue, Fuhai Street, Bao'an District,  
Shenzhen, China

---

**Tested by (name + signature)** ..... : Alen He

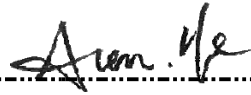

**Reviewer (name + signature)** ..... : Joe Liu



**Approved (name + signature)** ..... : Lake Xie



## TABLE OF CONTENTS

<b>1. VERSION</b>	<b>4</b>
<b>2. TEST SUMMARY</b>	<b>5</b>
2.2 MEASUREMENT UNCERTAINTY	5
<b>3. GENERAL INFORMATION</b>	<b>6</b>
3.1 GENERAL DESCRIPTION OF EUT	6
3.2 Test mode	6
3.3 Block Diagram of EUT Configuration	6
3.4 Test Conditions	7
3.5 Description Of Support Units (Conducted Mode)	7
3.6 EQUIPMENTS LIST FOR ALL TEST ITEMS	8
<b>4. CONDUCTED EMISSION TEST</b>	<b>9</b>
4.1 CONDUCTED EMISSION MEASUREMENT	9
4.1.1 POWER LINE CONDUCTED EMISSION Limits	9
4.1.2 TEST PROCEDURE	9
4.1.3 DEVIATION FROM TEST STANDARD	9
4.1.4 TEST SETUP	10
4.1.5 EUT OPERATING CONDITIONS	10
4.1.6 Test Result	10
<b>5. RADIATED EMISSION MEASUREMENT</b>	<b>13</b>
5.1 Radiated Emission Limits	13
5.2 Anechoic Chamber Test Setup Diagram	14
5.3 Test Procedure	14
5.4 DEVIATION FROM TEST STANDARD	14
5.5 Test Result	15
<b>6. BANDWIDTH TEST</b>	<b>18</b>
<b>7. TEST SETUP PHOTO</b>	<b>21</b>
<b>8. EUT CONSTRUCTIONAL DETAILS</b>	<b>23</b>

**1. VERSION**

Report No.	Version	Description	Approved
ZKT-220222L0960	Rev.01	Initial issue of report	Feb. 29, 2022

## 2. TEST SUMMARY

Test Item	Section in CFR 47	Result
Antenna requirement	15.203	Pass
AC Power Line Conducted Emission	15.207	Pass
Spurious Emission	15.209(a)(f)	Pass
20dB Bandwidth	15.215	Pass

NOTE: (1) "N/A" denotes test is not applicable in this Test Report

### 2.1 TEST FACILITY

Shenzhen ZKT Technology Co., Ltd.  
Add. : 1/F, No. 101, Building B, No. 6, Tangwei Community Industrial Avenue, Fuhai Street,  
Bao'an District, Shenzhen, China

FCC Test Firm Registration Number: 692225  
Designation Number: CN1299  
IC Registered No.: 27033

### 2.2 MEASUREMENT UNCERTAINTY

The reported uncertainty of measurement  $y \pm U$ , where expanded uncertainty  $U$  is based on a standard uncertainty multiplied by a coverage factor of  $k=2$ , providing a level of confidence of approximately 95 %.

No.	Item	Uncertaint
1	3m camber Radiated spurious emission(30MHz-1GHz)	U=4.3dB
2	3m chamber Radiated spurious emission(1GHz-18GHz)	U=4.5dB
3	3m chamber Radiated spurious mission(18GHz-40GHz)	U=3.34dB
4	Conducted Adjacent channel power	U=1.38dB
5	Conducted output power uncertainty Above 1G	U=1.576dB
6	Conducted output power uncertainty below 1G	U=1.28dB
7	humidity uncertainty	U=5.3%
8	Temperature uncertainty	U=0.59°C
9	Radiated disturbance(30MHz-1000MHz)	U=4.8dB
10	Radiated disturbance(1GHz-6GHz)	U=4.9dB
11	Radiated disturbance(1GHz-18GHz)	U=5.0dB
12	3m camber Radiated spurious emission(9KHz-30MHz)	U=4.5dB

### 3. GENERAL INFORMATION

#### 3.1 GENERAL DESCRIPTION OF EUT

Product Name:	3 in1 wireless charger
Model No.:	FD05
Serial No.:	/
Hardware version:	V2.0
Software version:	/
Operation Frequency:	112KHz -- 205KHz
Test Frequency:	114.6KHz, 127.8KHz, 144.0 KHz
Modulation type:	MSK
Antenna Type:	Inductive loop coil Antenna
Antenna gain:	0dBi
Power supply:	Input:5V 3A /9V 2A Output1: 5W/7.5W/10W Output2: 5W Output1: 2.5W

#### 3.2 Test mode

Transmitting mode	
Mode1	Charging cellphone output: 15W
Mode2	Charging watch output: 2.5W
Mode3	Charging Earbuds: 5W
Mode4	Mode3+ Mode2+ Mode1

NOTE: Mode 4 is the full load mode, and the full load mode is the worst mode;

#### Test channel

Channel	Test Frequency(KHz)
Earbuds loop coil Antenna	114.6KHz
Cellphone loop coil Antenna	127.8KHz
watch loop coil Antenna	144.0 KHz

#### 3.3 Block Diagram of EUT Configuration

##### Conducted Emission

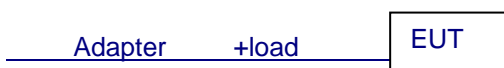

##### Radiated Emission



### 3.4 Test Conditions

Temperature: 23~26°C

Relative Humidity: 54~63 %

### 3.5 Description Of Support Units (Conducted Mode)

The EUT has been tested as an independent unit together with other necessary accessories or support units. The following support units or accessories were used to form a representative test configuration during the tests.

Item	Equipment	Mfr/Brand	Model/Type No.	Series No.	Note
E1	power adapter	N/A	TCS-QC530	N/A	Auxiliary
E2	Watch	Apple	Apple watch	N/A	Auxiliary
E3	mobile phone	Huawei	p40pro	N/A	Auxiliary
E4	earbuds	Apple		N/A	Auxiliary

Item	Shielded Type	Ferrite Core	Length	Note
C1	NO	NO	1.0M	DC cable unshielded

Note:

- (1) The support equipment was authorized by Declaration of Confirmation.
- (2) For detachable type I/O cable should be specified the length in cm in 『Length』 column.
- (3) “YES” is means “shielded” “with core”; “NO” is means “unshielded” “without core”.

### 3.6 EQUIPMENTS LIST FOR ALL TEST ITEMS

#### Radiation Test equipment

Item	Equipment	Manufacturer	Type No.	Serial No.	Last calibration	Calibrated until
1	Spectrum Analyzer (9kHz-26.5GHz)	KEYSIGHT	9020A	MY45109572	Sep. 21, 2021	Sep. 20, 2022
2	Spectrum Analyzer (1GHz-40GHz)	Agilent	E4446A	100363	Sep. 21, 2021	Sep. 20, 2022
3	Test Receiver (9kHz-7GHz)	R&S	ESC17	101169	Sep. 21, 2021	Sep. 20, 2022
4	Bilog Antenna (30MHz-1400MHz)	Schwarzbeck	VULB9168	00877	Sep. 21, 2021	Sep. 20, 2022
5	Horn Antenna (1GHz-18GHz)	SCHWARZBECK	BBHA9120D	1541	Sep. 21, 2021	Sep. 20, 2022
6	Horn Antenna (18GHz-40GHz)	A.H. System	SAS-574	588	Sep. 21, 2021	Sep. 20, 2022
7	Amplifier (30-1000MHz)	EM Electronics	EM330 Amplifier	N/A	Sep. 21, 2021	Sep. 20, 2022
8	Amplifier (1GHz-40GHz)	QUANJUDA	DLE-161	097	Sep. 21, 2021	Sep. 20, 2022
9	Loop Antenna (9KHz-30MHz)	SCHWARZBECK	FMZB1519B	014	Sep. 21, 2021	Sep. 20, 2022
10	RF cables1 (9kHz-30MHz)	N/A	9kHz-30MHz	N/A	Sep. 21, 2021	Sep. 20, 2022
11	RF cables2 (30MHz-1GHz)	N/A	30MHz-1GHz	N/A	Sep. 21, 2021	Sep. 20, 2022
12	RF cables3 (1GHz-40GHz)	N/A	1GHz-40GHz	N/A	Sep. 21, 2021	Sep. 20, 2022
13	CMW500 Test	R&S	CMW500	106504	Sep. 21, 2021	Sep. 20, 2022
14	ESG Signal Generator	Agilent	E4421B	GB40051203	Sep. 21, 2021	Sep. 20, 2022
15	Signal Generator	Agilent	N5182A	MY47420215	Sep. 21, 2021	Sep. 20, 2022
16	D.C. Power Supply	LongWei	TPR-6405D	\	\	\
17	Software	Frad	EZ-EMC	FA-03A2 RE	\	\

#### Conduction Test equipment

Item	Kind of Equipment	Manufacturer	Type No.	Serial No.	Last calibration	Calibrated until
1	LISN	R&S	ENV216	101471	Sep. 21, 2021	Sep. 20, 2022
2	LISN	CYBERTEK	EM5040A	E1850400149	Sep. 21, 2021	Sep. 20, 2022
3	Test Cable	N/A	C01	N/A	Sep. 21, 2021	Sep. 20, 2022
4	Test Cable	N/A	C02	N/A	Sep. 21, 2021	Sep. 20, 2022
5	EMI Test Receiver	R&S	ESRP3	101946	Sep. 21, 2021	Sep. 20, 2022
6	Absorbing Clamp	DZ	ZN23201	N/A	Sep. 21, 2021	Sep. 20, 2022



#### 4. CONDUCTED EMISSION TEST

##### 4.1 CONDUCTED EMISSION MEASUREMENT

Test Requirement:	FCC Part15 C Section 15.207
Test Method:	ANSI C63.10:2013
Test Frequency Range:	150KHz to 30MHz
Receiver setup:	RBW=9KHz, VBW=30KHz, Sweep time=auto

##### 4.1.1 POWER LINE CONDUCTED EMISSION Limits

FREQUENCY (MHz)	Limit (dBuV)		Standard
	Quas -peak	Average	
0.15 -0.5	66 - 56 *	56 - 46 *	FCC
0.50 -5.0	56.00	46.00	FCC
5.0 -30.0	60.00	50.00	FCC

Note:

(1) \*Decreases with the logarithm of the frequency.

##### 4.1.2 TEST PROCEDURE

- a. The EUT was placed 0.8 meters from the horizontal ground plane with EUT being connected to the power mains through a line impedance stabilization network (LISN). All other support equipments powered from additional LISN(s). The LISN provide 50 Ohm/ 50uH of coupling impedance for the measuring instrument.
- b. Interconnecting cables that hang closer than 40 cm to the ground plane shall be folded back and forth in the center forming a bundle 30 to 40 cm long.
- c. I/O cables that are not connected to a peripheral shall be bundled in the center. The end of the cable may be terminated, if required, using the correct terminating impedance. The overall length shall not exceed 1 m.
- d. LISN at least 80 cm from nearest part of EUT chassis.
- e. For the actual test configuration, please refer to the related Item –EUT Test Photos.

##### 4.1.3 DEVIATION FROM TEST STANDARD

No deviation

#### 4.1.4 TEST SETUP

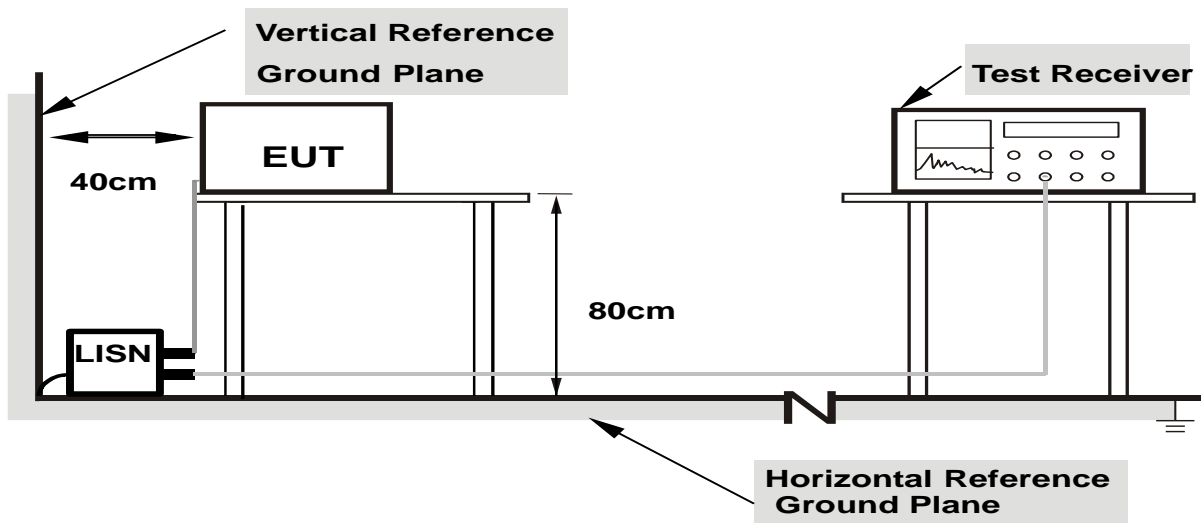

- Note: 1.Support units were connected to second LISN.**  
**2.Both of LISNs (AMN) are 80 cm from EUT and at least 80 from other units and other metal planes**

#### 4.1.5 EUT OPERATING CONDITIONS

The EUT was configured for testing in a typical fashion (as a customer would normally use it). The EUT has been programmed to continuously transmit during test. This operating condition was tested and used to collect the included data.

#### 4.1.6 Test Result

Temperature:	26°C	Relative Humidity:	54%
Pressure:	101kPa	Phase :	L
Test Voltage :	AC 120V/60Hz	Test mode	Mode 4

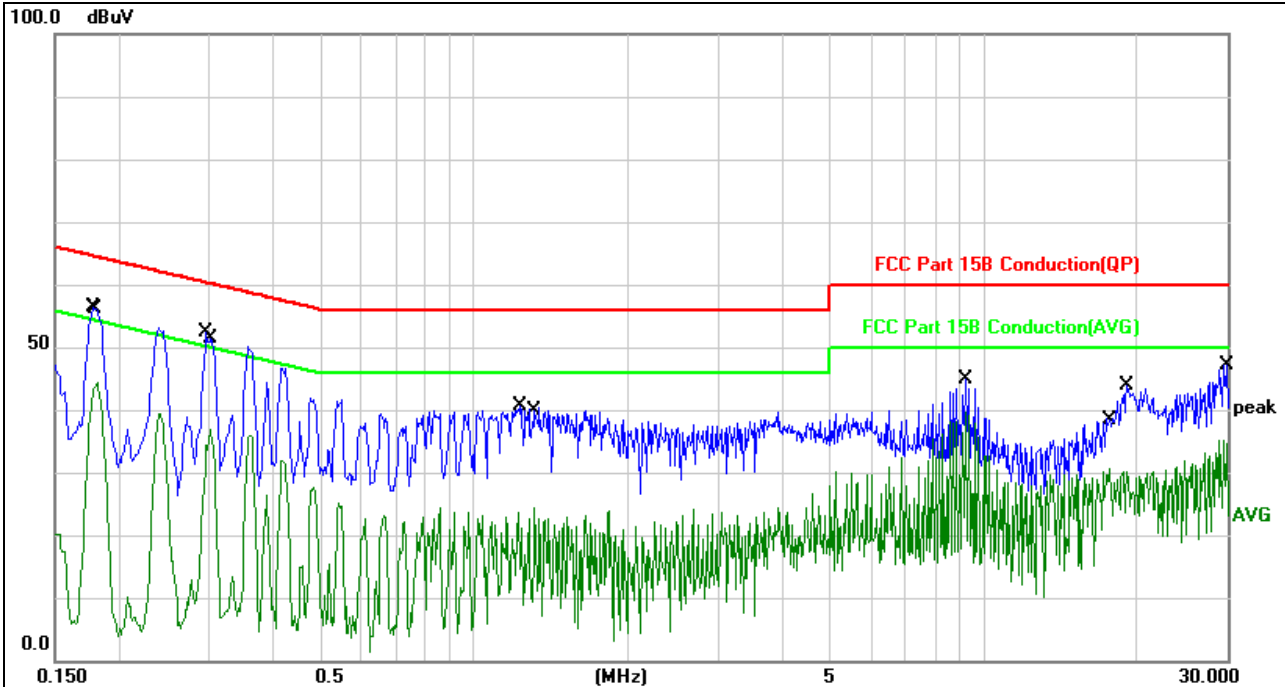

No.	Mk.	Freq.	Reading Level	Correct Factor	Measurement	Limit	Over	Detector	Comment
		MHz	dBuV	dB	dBuV	dBuV	dB		
1		0.1780	46.67	9.75	56.42	64.57	-8.15	QP	
2		0.1819	34.69	9.75	44.44	54.39	-9.95	AVG	
3	*	0.2980	42.44	9.87	52.31	60.30	-7.99	QP	
4		0.3020	26.99	9.87	36.86	50.19	-13.33	AVG	
5		1.2340	31.01	9.73	40.74	56.00	-15.26	QP	
6		1.3140	14.59	9.71	24.30	46.00	-21.70	AVG	
7		9.2018	29.95	9.70	39.65	50.00	-10.35	AVG	
8		9.2059	35.23	9.70	44.93	60.00	-15.07	QP	
9		17.6459	20.92	9.59	30.51	50.00	-19.49	AVG	
10		19.0499	34.34	9.55	43.89	60.00	-16.11	QP	
11		29.5300	25.63	9.50	35.13	50.00	-14.87	AVG	
12		29.9140	37.67	9.49	47.16	60.00	-12.84	QP	

Notes:

1. An initial pre-scan was performed on the line and neutral lines with peak detector.
2. Quasi-Peak and Average measurement were performed at the frequencies with maximized peak emission.
3. Measurement Level = Reading level + Correct Factor
4. Mode 4 is the full load mode, and the full load mode is the worst mode;



## 5. RADIATED EMISSION MEASUREMENT

Test Requirement:	FCC Part15 C Section 15.209				
Test Method:	ANSI C63.10:2013				
Test Frequency Range:	9kHz to 1GHz				
Test site:	Measurement Distance: 3m				
Receiver setup:	Frequency	Detector	RBW	VBW	Value
	9KHz-150KHz	Quasi-peak	200Hz	600Hz	Quasi-peak
	150KHz-30MHz	Quasi-peak	9KHz	30KHz	Quasi-peak
	30MHz-1GHz	Quasi-peak	120KHz	300KHz	Quasi-peak
	Above 1GHz	Peak	1MHz	3MHz	Peak
		Peak	1MHz	10Hz	Average

### 5.1 Radiated Emission Limits

#### Limits for frequency below 30MHz

Frequency	Limit (uV/m)	Measurement Distance(m)	Remark
0.009-0.490	2400/F(kHz)	300	Quasi-peak Value
0.490-1.705	24000/F(kHz)	30	Quasi-peak Value
1.705-30	30	30	Quasi-peak Value

#### Limits for frequency Above 30MHz

Frequency	Limit (dBuV/m @3m)	Remark
30MHz-88MHz	40.00	Quasi-peak Value
88MHz-216MHz	43.50	Quasi-peak Value
216MHz-960MHz	46.00	Quasi-peak Value
960MHz-1GHz	54.00	Quasi-peak Value
Above 1GHz	54.00	Average Value
	74.00	Peak Value

## 5.2 Anechoic Chamber Test Setup Diagram

### (A) Radiated Emission Test-Up Frequency Below 30MHz

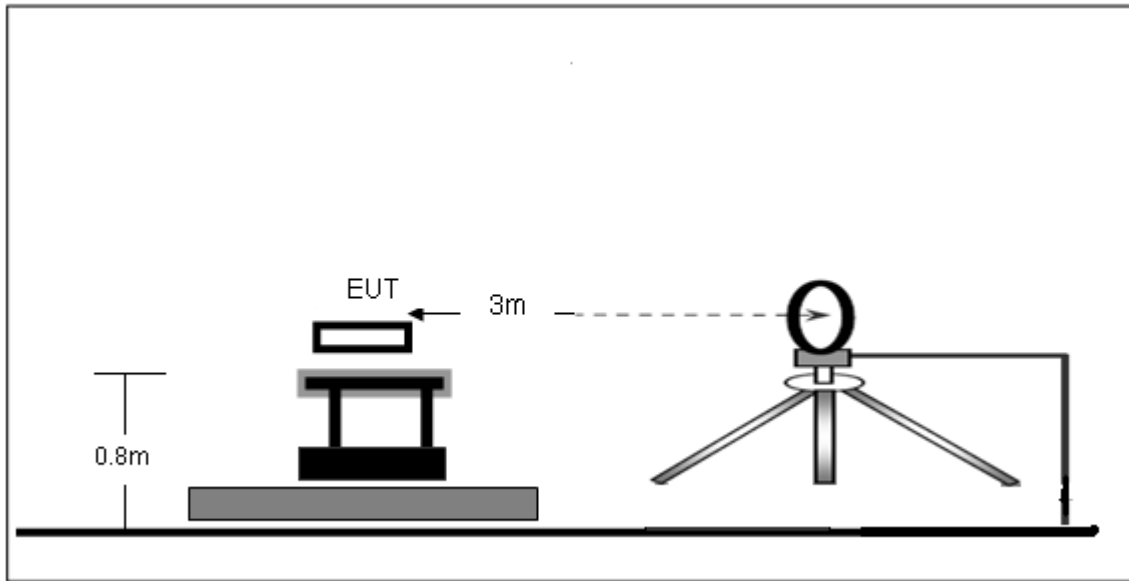

### (B) Radiated Emission Test-Up Frequency 30MHz~1GHz

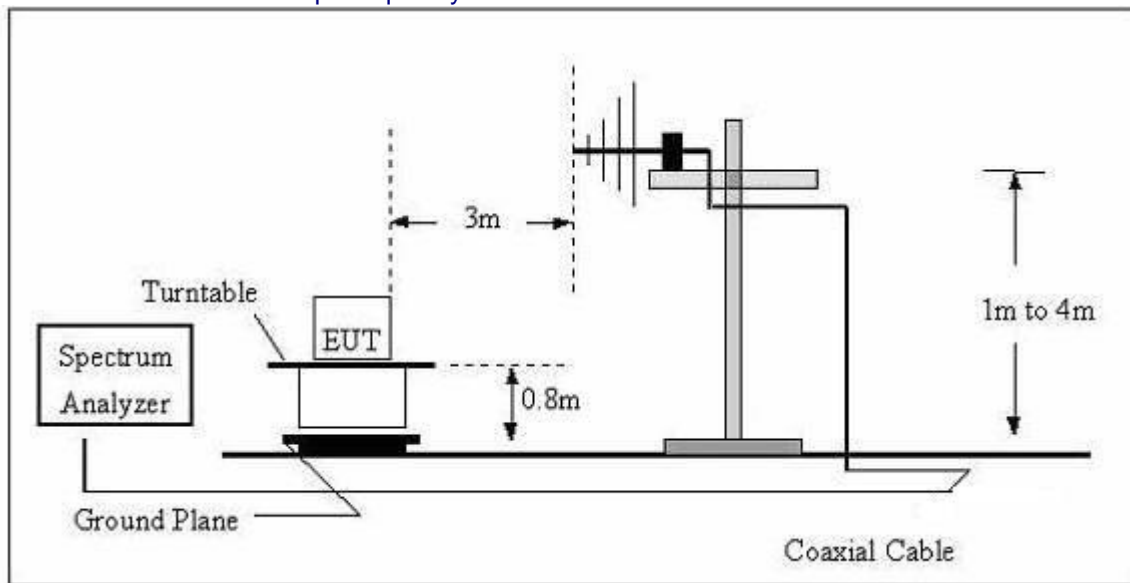

The radiated emission tests were performed in the 3 meters chamber test site, using the setup accordance with the ANSI C63.10-2013. The specification used was the FCC 15.209 and FCC 15.205 limits.

## 5.3 Test Procedure

The EUT is placed on a turn table which is 0.8 meter above ground. The turn table can rotate 360 degrees to determine the position of the maximum emission level. The EUT is set 3 meters away from the receiving antenna which is mounted on a antenna tower. The antenna can move up and down between 1 to 4 meters to find out the maximum emission level. Broadband antenna (calibrated by dipole antenna) are used as a receiving antenna. Both horizontal and vertical polarization of the antenna are set on measurement.

## 5.4 DEVIATION FROM TEST STANDARD

No deviation

5.5 Test Result

Measurement data:

Note: Limit dBuV/m @3m = Limit dBuV/m @300m+ 80

Limit dBuV/m @3m = Limit dBuV/m @30m + 40

9 kHz~30 MHz

Frequency	Meter Reading	Antenna Factor	Cable Loss	Emission Levels	Limits at 3m	Detector Mode
(MHz)	(dBμV)	(dB/m)	(dB)	(dBμV/m)	(dBμV/m)	
0.1022	42.51	23.62	-0.17	65.96	107.42	QP
0.1278	74.45	23.62	-0.17	97.90	105.45	QP
0.1725	48.06	23.62	-0.17	71.51	102.87	QP
0.3291	48.36	23.61	0.01	71.98	97.26	QP
0.688	32.93	27.15	-0.25	59.83	70.85	QP
1.474	31.64	27.15	-0.25	58.54	64.23	QP
5.61	34.14	23.72	-0.24	57.62	69.54	QP
16.22	33.65	23.72	-0.24	57.13	69.54	QP

Note:

Pre-scan in the all of mode, the worst case in of was recorded.

Factor = antenna factor + cable loss – pre-amplifier.

Margin = Emission Level- Limit.

Mode 4 is the full load mode, and the full load mode is the worst mode;

30MHz-1GHz

Temperature:	26°C	Relative Humidity:	54%
Pressure:	101 kPa	Polarization:	Horizontal
Test Voltage:	AC 120V/60Hz	Test mode	Mode 4

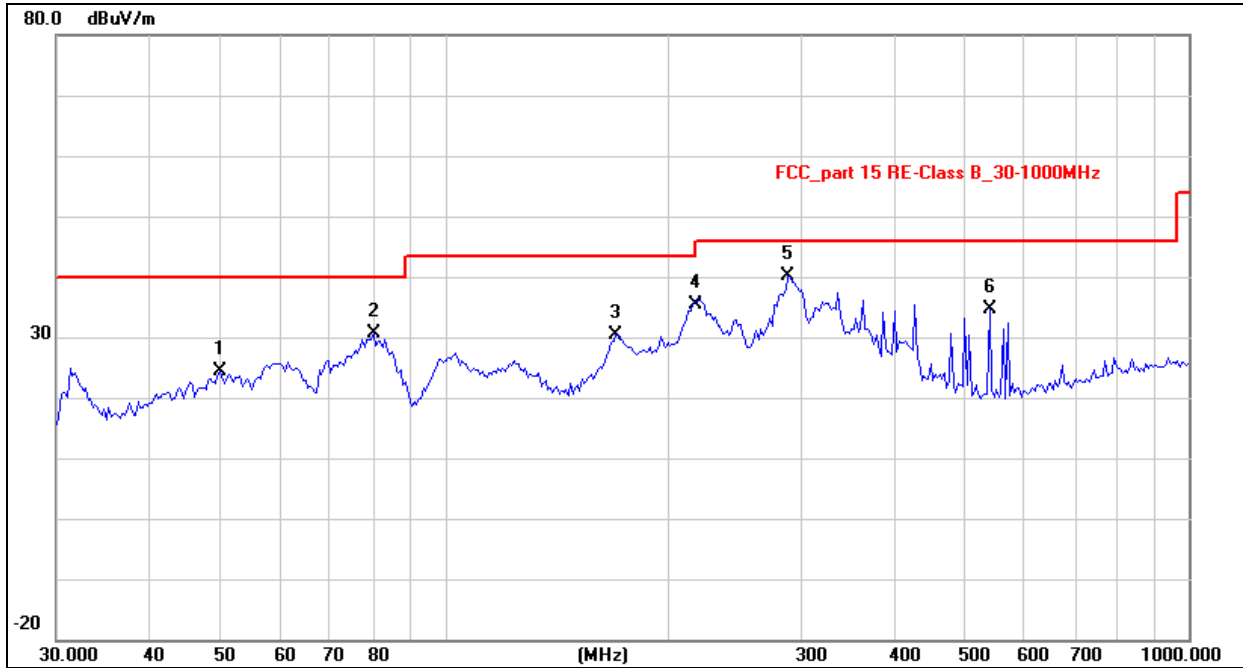

No.	Mk.	Freq.	Reading Level	Correct Factor	Measurement	Limit	Over	Antenna Height	Table Degree	
		MHz	dBuV	dB/m	dBuV/m	dBuV/m	dB	cm	degree	Comment
1		49.7068	40.69	-16.39	24.30	40.00	-15.70	QP 100	0	
2		80.0806	51.34	-20.65	30.69	40.00	-9.31	QP 100	0	
3		169.5990	46.62	-16.20	30.42	43.50	-13.08	QP 100	0	
4		215.2678	54.63	-19.33	35.30	43.50	-8.20	QP 100	0	
5	*	289.0021	56.11	-15.91	40.20	46.00	-5.80	QP 100	0	
6		539.4775	44.28	-9.59	34.69	46.00	-11.31	QP 100	0	

Remarks:

1. Final Level = Receiver Read level + Antenna Factor + Cable Loss – Pre-amplifier Factor
2. The emission levels of other frequencies are very lower than the limit and not show in test report.
3. Mode 4 is the full load mode, and the full load mode is the worst mode;



Temperature:	26°C	Relative Humidity:	54%
Pressure:	101kPa	Polarization:	Vertical
Test Voltage:	AC 120V/60Hz	Test mode	Mode 4

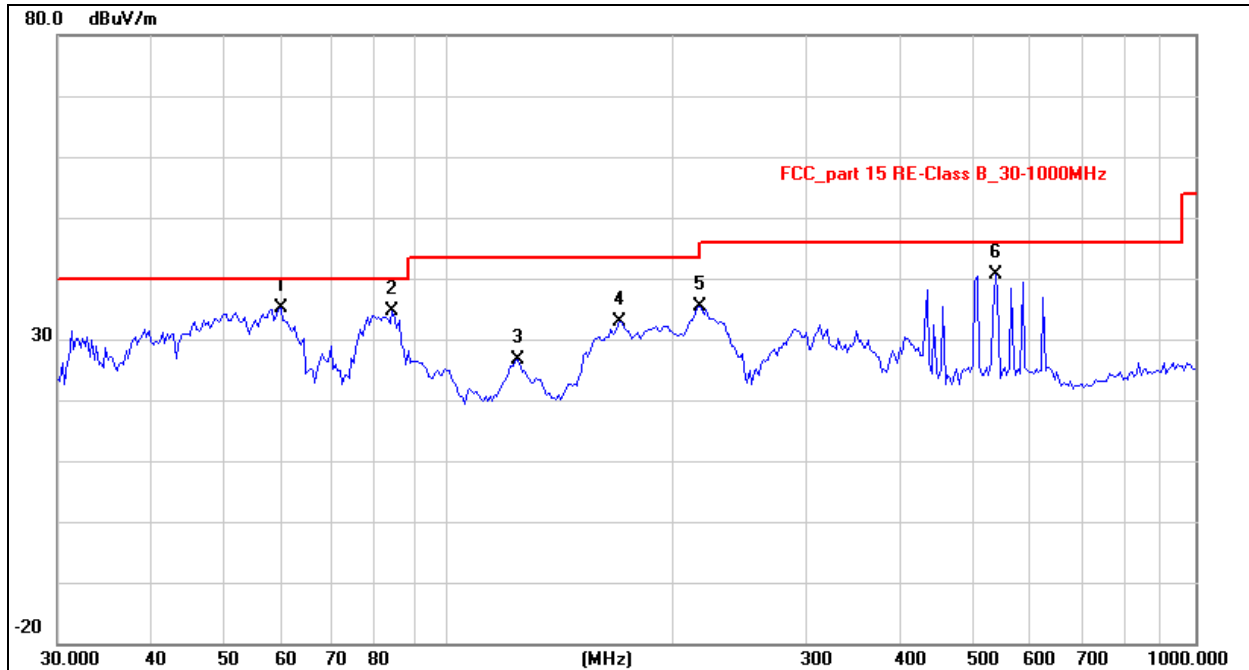

No.	Mk.	Freq.	Reading Level	Correct Factor	Measurement	Limit	Over	Antenna Height	Table Degree	
		MHz	dBuV	dB/m	dBuV/m	dBuV/m	dB	cm	degree	Comment
1	*	59.6493	52.12	-17.02	35.10	40.00	-4.90	QP	100	360
2		84.1100	55.28	-20.65	34.63	40.00	-5.37	QP	100	360
3		123.6984	44.16	-17.64	26.52	43.50	-16.98	QP	100	360
4		169.5990	49.10	-16.20	32.90	43.50	-10.60	QP	100	360
5		216.7828	54.77	-19.34	35.43	46.00	-10.57	QP	100	360
6		539.4775	50.16	-9.59	40.57	46.00	-5.43	QP	100	360

Remarks:

1. Final Level = Receiver Read level + Antenna Factor + Cable Loss – Preamplifier Factor
2. The emission levels of other frequencies are very lower than the limit and not show in test report.
3. Mode 4 is the full load mode, and the full load mode is the worst mode;

## 6. BANDWIDTH TEST

1. Set RBW = 3 kHz.
2. Set the video bandwidth (VBW)  $\geq 3 \times$  RBW.
3. Detector = Peak.
4. Trace mode = max hold.
5. Sweep = auto couple.
6. Allow the trace to stabilize.
7. Measure the maximum width of the emission that is constrained by the frequencies associated with the two outermost amplitude points (upper and lower frequencies) that are attenuated by 20 dB relative to the maximum level measured in the fundamental emission.

### TEST SETUP



Temperature:	26 °C	Relative Humidity:	54%
Pressure:	101kPa		

Frequency (KHz)	Antenna	20dB bandwidth (KHz)	99% bandwidth (KHz)	Result
114.6	Earbuds loop coil Antenna:	10.42	8.816	Pass
127.8	Cellphone loop coil Antenna	8.313	7.156	Pass
144.0	watch loop coil Antenna	8.266	7.250	Pass

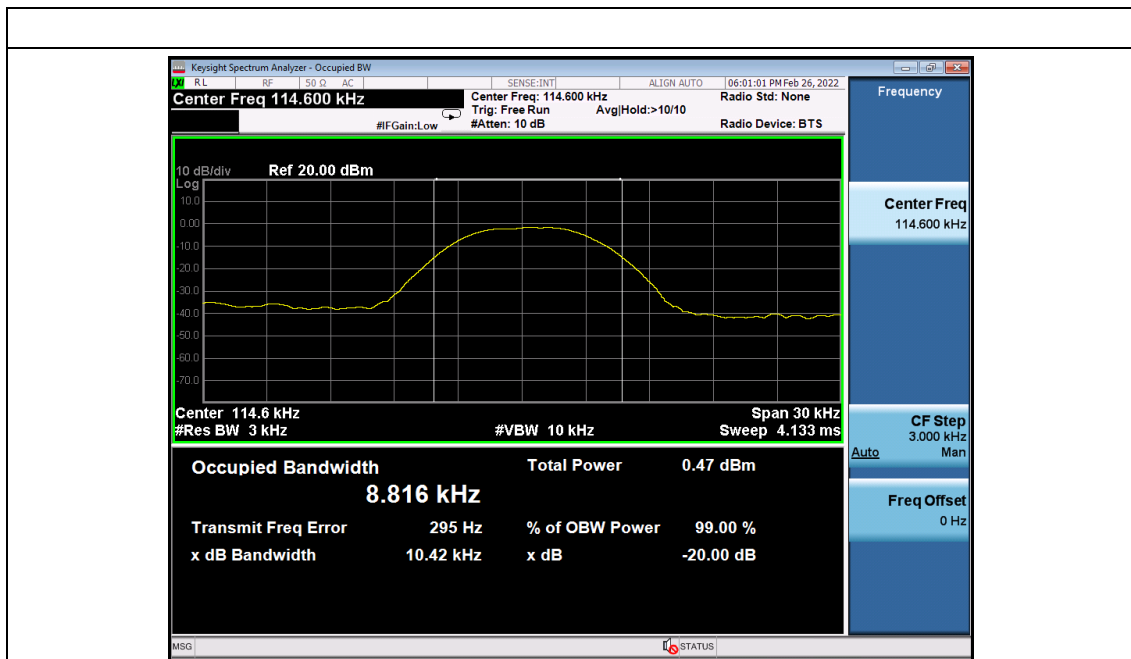

114.6KHz

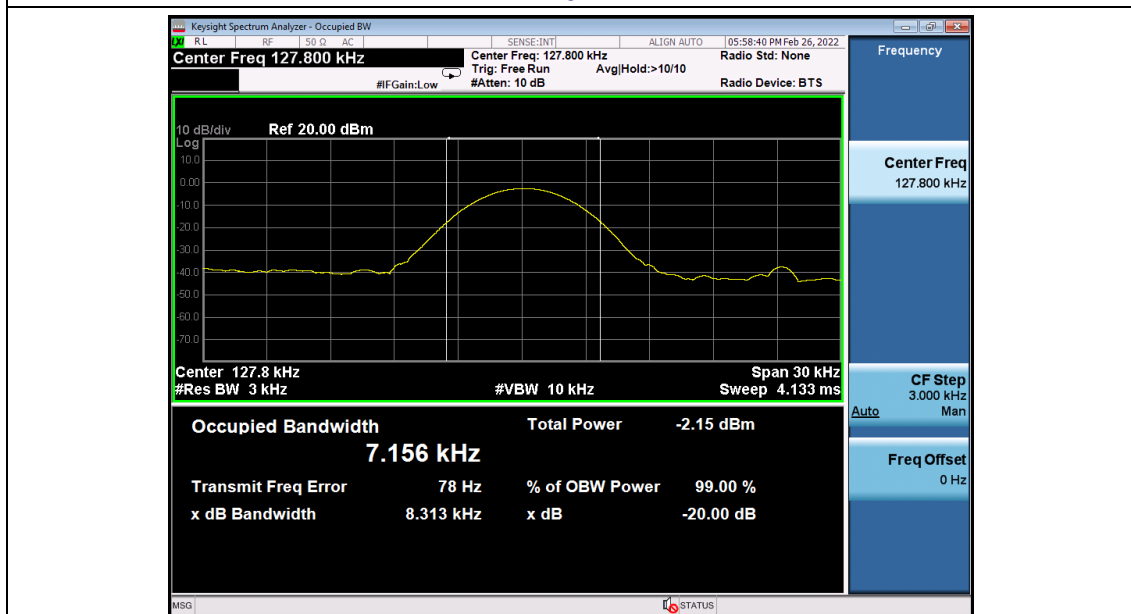

127.8KHz

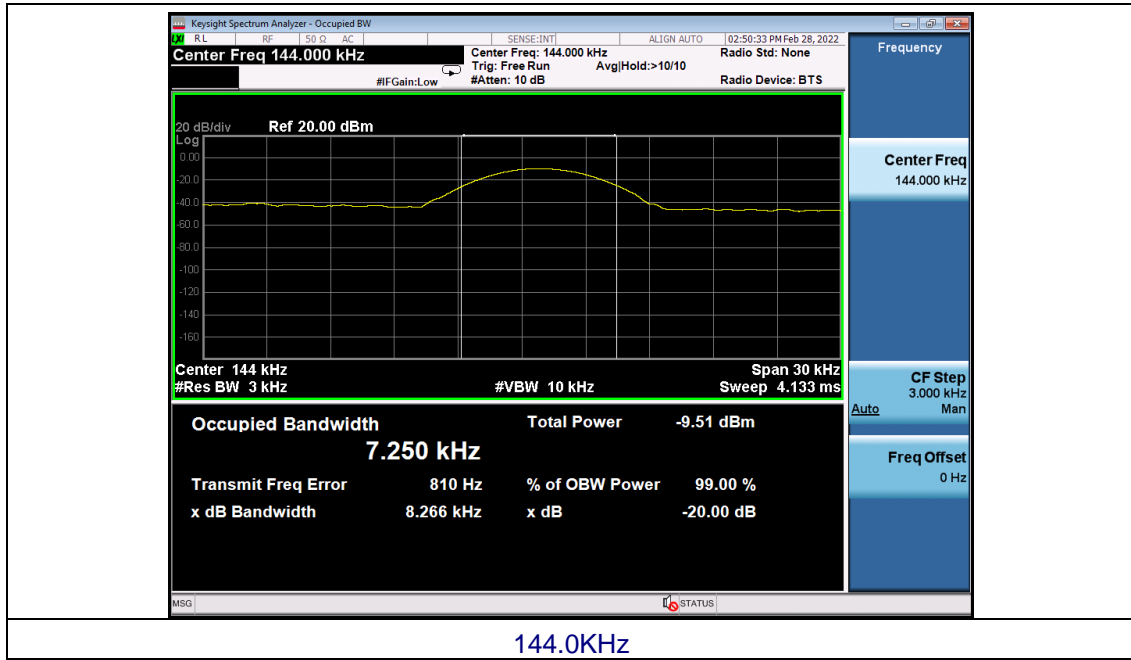

**7. TEST SETUP PHOTO**





## 8. EUT CONSTRUCTIONAL DETAILS

Reference to the External photos file and internal photos file for details.

**\*\*\*\*\* END OF REPORT \*\*\*\*\***