



RF MEASUREMENT REPORT

FCC ID: 2A46G-TR24S100
Applicant: Guangzhou Xaircraft Technology CO., LTD
Product: Radar
Model No.: TR24S100
FCC Classification: Part 15 Low Power Communication Device Transmitter (DXX)
FCC Rule Part(s): Part 15.249
Test Procedure(s): ANSI C63.10 - 2013
Test Date: April 06 ~ April 22, 2022

Reviewed By:

Vincent Yu

Approved By:

Robin Wu



The test results relate only to the samples tested.

This equipment has been shown to be capable of compliance with the applicable technical standards as indicated in the measurement report and was tested in accordance with the measurement procedures specified in ANSI C63.10-2013. Test results reported herein relate only to the item(s) tested.

The test report shall not be reproduced except in full without the written approval of MRT Technology (Suzhou) Co., Ltd.

Revision History

Report No.	Version	Description	Issue Date	Note
2202RSU040-U1	Rev. 01	Initial Report	04-25-2022	Valid

CONTENTS

Description	Page
1. GENERAL INFORMATION	5
1.1. Applicant.....	5
1.2. Manufacturer	5
1.3. Testing Facility	5
1.4. Product Information	6
1.5. Radio Specification.....	6
2. TEST CONFIGURATION	7
2.1. Test Mode.....	7
2.2. Test Configuration	7
2.3. Test Environment Condition	7
3. ANTENNA REQUIREMENTS	8
4. TEST EQUIPMENT CALIBRATION DATE	9
5. MEASUREMENT UNCERTAINTY	10
6. TEST RESULT.....	11
6.1. Summary	11
6.2. AC Conducted Emissions Measurement	12
6.2.1. Test Limit.....	12
6.2.2. Test Setup.....	12
6.2.3. Test Result.....	12
6.3. Radiated Emission	13
6.3.1. Test Limit.....	13
6.3.2. Test Procedure Used	14
6.3.3. Test Setting	14
6.3.4. Test Setup.....	16
6.3.5. Test Result.....	18
6.4. Radiated Restricted Band Edge Measurement.....	22
6.4.1. Test Limit.....	22
6.4.2. Test Procedure Used	23
6.4.3. Test Setting	23
6.4.4. Test Setup.....	24
6.4.5. Test Result.....	25
6.5. 20dB Spectrum Bandwidth Measurement.....	29
6.5.1. Test Limit.....	29
6.5.2. Test Procedure used.....	29
6.5.3. Test Setting	29
6.5.4. Test Setup.....	29
6.5.5. Test Result.....	30

Appendix A - Test Setup Photograph 31
Appendix B - EUT Photograph..... 32

1.4. Product Information

Product Name	Radar
Model No.	TR24S100
Test Device No.	413412000494
Temperature	-40°C ~ 85°C
Power Supply	DC 5.8V
Remark: The information of EUT was provided by the manufacturer, and the accuracy of the information shall be the responsibility of the manufacturer.	

1.5. Radio Specification

Frequency Range	24.00 ~ 24.25GHz
Type of Modulation	FMCW
Antenna Type	Integrated Antenna
Max. Antenna Gain	15dBi

2. TEST CONFIGURATION

2.1. Test Mode

Mode 1: Collocated TX/RX mode

Note: The test sample was provided by the manufacturer, which was configured into Collocated Tx/Rx mode after power on.

2.2. Test Configuration

This device was tested per the guidance ANSI C63.10:2013 was used to reference the appropriate EUT setup for radiated emissions testing.

Connection Diagram

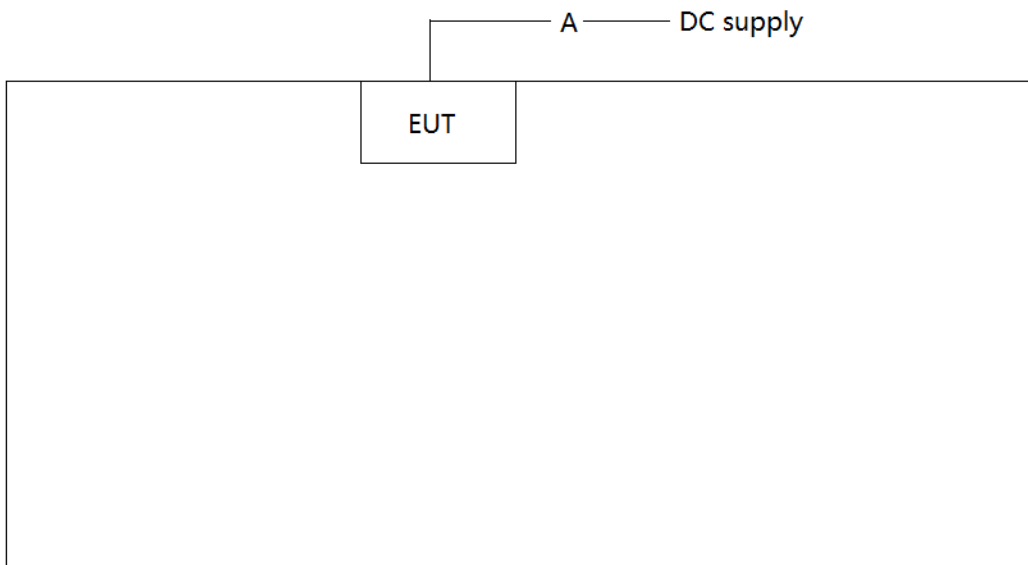

Cable Type		Cable Description
A	Power Cable	Non-Shielding, 0.3m

2.3. Test Environment Condition

Ambient Temperature	15°C ~ 35°C
Relative Humidity	20%RH ~ 75%RH

3. ANTENNA REQUIREMENTS

Excerpt from §15.203 of the FCC Rules/Regulations:

“An intentional radiator antenna shall be designed to ensure that no antenna other than that furnished by the responsible party can be used with the device. The use of a permanently attached antenna or of an antenna that uses a unique coupling to the intentional radiator shall be considered sufficient to comply with the provisions of this section.”

- The antenna of Wired Dual-Tech AM Curtain Detector is **permanently attached**.
- There are no provisions for connection to an external antenna.

Conclusion:

This unit complies with the requirement of §15.203.

4. TEST EQUIPMENT CALIBRATION DATE

Instrument	Manufacturer	Model No.	Asset No.	Cali. Interval	Cali. Due Date	Test Site
EMI Test Receiver	R&S	ESR3	MRTSUE06185	1 year	2022/12/29	SIP-AC2
Signal Analyzer	Keysight	N9010B	MRTSUE06559	1 year	2022/6/24	SIP-AC2
Horn Antenna	Schwarzbeck	BBHA 9170	MRTSUE06599	1 year	2022/10/20	SIP-AC2/SIP-TR2
Preamplifier	EMCI	EMC184045SE	MRTSUE06602	1 year	2022/10/11	SIP-AC2
EMI Test Receiver	R&S	ESR3	MRTSUE06613	1 year	2022/6/24	SIP-AC2
Thermohygrometer	testo	608-H1	MRTSUE06623	1 year	2022/11/28	SIP-AC2
Thermohygrometer	testo	608-H1	MRTSUE06624	1 year	2022/11/28	SIP-AC2
Preamplifier	EMCI	EMC001330	MRTSUE06643	1 year	2023/1/13	SIP-AC2
Preamplifier	EMCI	EMC051845SE	MRTSUE06644	1 year	2022/11/8	SIP-AC2
TRILOG Antenna	Schwarzbeck	VULB 9168	MRTSUE06647	1 year	2022/8/5	SIP-AC2
Horn Antenna	Schwarzbeck	BBHA 9120D	MRTSUE06648	1 year	2022/11/9	SIP-AC2
Anechoic Chamber	RIKEN	SIP-AC2	MRTSUE06781	1 year	2022/12/23	SIP-AC2
Loop Antenna	Schwarzbeck	FMZB 1519 B	MRTSUE06937	1 year	2023/3/14	SIP-AC2
Waveguide Harmonic Mixer	Keysight	M1970V	MRTSUE06271	/	/	SIP-TR2
Waveguide Harmonic Mixer	Keysight	M1970W	MRTSUE06272	/	/	SIP-TR2
mmWave Antenna	MI-WWAVE	261U-25/383	MRTSUE06273	/	/	SIP-TR2
mmWave Antenna	A-INFO	LB-15-25-A	MRTSUE06409	/	/	SIP-TR2
mmWave Antenna	A-INFO	LB-10-25-A	MRTSUE06410	/	/	SIP-TR2
Thermohygrometer	testo	622	MRTSUE06628	1 year	2023/1/6	SIP-TR2
Signal Analyzer	Keysight	N9030B	MRTSUE06395	1 year	2022/8/8	SIP-TR2

Software	Version	Function
EMI V3	V 3.0.0	EMI Test Software
Controller_MF 7802BS	1.02	RE Antenna&turntable
MotorContor	V 2	mmw

5. MEASUREMENT UNCERTAINTY

Where relevant, the following test uncertainty levels have been estimated for tests performed on the EUT as specified in CISPR 16-4-2. This uncertainty represents an expanded uncertainty expressed at approximately the 95% confidence level using a coverage factor of $k = 2$.

AC Conducted Emission Measurement
Measurement Uncertainty for a Level of Confidence of 95% ($U=2Uc(y)$): 9kHz~150kHz: 3.74dB 150kHz~30MHz: 3.44dB
Radiated Emission Measurement
Measurement Uncertainty for a Level of Confidence of 95% ($U=2Uc(y)$): Horizontal: 30MHz~300MHz: 5.04dB 300MHz~1GHz: 4.95dB 1GHz~40GHz: 6.40dB Vertical: 30MHz~300MHz: 5.24dB 300MHz~1GHz: 6.03dB 1GHz~40GHz: 6.40dB

6. TEST RESULT

6.1. Summary

FCC Part Section(s)	Test Description	Test Condition	Verdict
15.207	AC Conducted Emissions 150kHz - 30MHz	Line Conducted	N/A
15.209 15.249	General Field Strength Limits (Restricted Bands and Radiated Emission Limits)	Radiated	Pass
15.215(c)	20dB Spectrum Bandwidth	Radiated	Pass

Notes:

1. The radiation measurements are performed in X, Y, Z axis positioning. The test results shown in the following sections represent the worst-case emissions.
2. The analyzer plots shown in this section were all taken with a correction table loaded into the analyzer. The correction table was used to account for the losses of the cables and attenuators used as part of the system to connect the EUT to the analyzer at all frequencies of interest.
3. "N/A" means that this item is not applicable, and the detail information refer to relevant section.

6.2. AC Conducted Emissions Measurement

6.2.1. Test Limit

FCC Part 15 Subpart C Paragraph 15.207 Limits		
Frequency (MHz)	QP (dB μ V)	Average (dB μ V)
0.15 - 0.50	66 - 56	56 - 46
0.50 - 5.0	56	46
5.0 - 30	60	50

Note 1: The lower limit shall apply at the transition frequencies.

Note 2: The limit decreases linearly with the logarithm of the frequency in the range 0.15MHz to 0.5MHz.

6.2.2. Test Setup

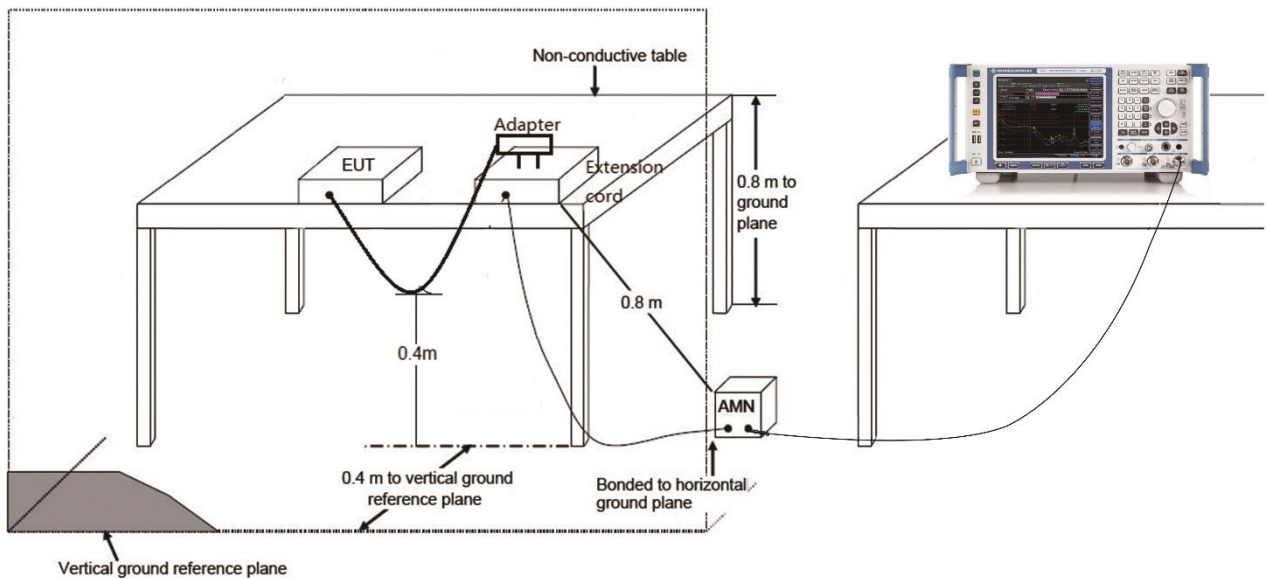

6.2.3. Test Result

The EUT is powered by DC power supply, so this requirement is not applicable.

6.3. Radiated Emission

6.3.1. Test Limit

FCC Part 15 Subpart C Paragraph 15.249		
Fundamental Frequency (MHz)	Field Strength of Fundamental (mV/m)	Field Strength of Harmonics (μ V/m)
902 ~ 928	50	500
2400 ~ 2483.5	50	500
5725 ~ 5875	50	500
24000 ~ 24250	250	2500

Note: FCC Part 15.249 (d), Emissions radiated outside of the specified frequency bands, except for harmonics, shall be attenuated by at least 50 dB below the level of the fundamental or to the general radiated emission limits in §15.209, whichever is the lesser attenuation.

FCC Part 15 Subpart C Paragraph 15.209		
Frequency (MHz)	Field Strength (μ V/m)	Measurement Distance (m)
0.009 ~ 0.490	2400/F(kHz)	300
0.490 ~ 1.705	24000/F(kHz)	30
1.705 ~ 30.0	30	30
30 ~ 88	100	3
88 ~ 216	150	3
216 ~ 960	200	3
Above 960	500	3

Note 1: The lower limit shall apply at the transition frequency.

Note 2: Distance refers to the distance in meters between the measuring instrument antenna and the closed point of any part of the device or system.

Note 3: E field strength (dB μ V/m) = 20 log E field strength (μ V/m).

6.3.2. Test Procedure Used

ANSI C63.10-2013 Section 6.3

ANSI C63.10-2013 Section 6.4

ANSI C63.10-2013 Section 6.5

ANSI C63.10-2013 Section 6.6

6.3.3. Test Setting

Measurement of harmonic and spurious emissions above 40 GHz

1. Connect the test antenna covering the appropriate frequency range to a spectrum analyzer via an external mixer.
2. Set spectrum analyzer RBW = 1MHz, VBW = 3MHz, peak & average detector.
3. Maximize all observed emissions. Note the maximum power indicated on the spectrum analyzer. Adjust this reading, if necessary, by the conversion loss of the external mixer used at the frequency under investigation and the external mixer IF cable loss.
4. Calculate the maximum field strength of the emission at the measurement distance.
5. Calculate the power density at the distance specified by the limit from the field strength at the distance specified by the limit.
6. Repeat the preceding sequence for every emission observed in the frequency band under investigation.

Measurement of harmonic and spurious emissions below 40 GHz

Peak Field Strength Measurements

1. Analyzer center frequency was set to the frequency of the radiated spurious emission of interest
2. RBW = as specified in Table 1
3. VBW = 3 x RBW
4. Detector = Peak
5. Sweep time = auto couple
6. Trace mode = max hold
7. Trace was allowed to stabilize

Table 1 - RBW as a function of frequency

Frequency	RBW
9 ~ 150 kHz	200 Hz
0.15 ~ 30 MHz	9 kHz
30 ~ 1000 MHz	120 kHz
> 1000 MHz	1 MHz

Average Field Strength Measurements

1. Analyzer center frequency was set to the frequency of the radiated spurious emission of interest
2. RBW = 1MHz
3. VBW = 3*RBW
4. Detector = Peak
5. Sweep time = auto
6. Trace mode = max hold
7. Trace was allowed to stabilize

6.3.4. Test Setup

Below 1GHz Test Setup:

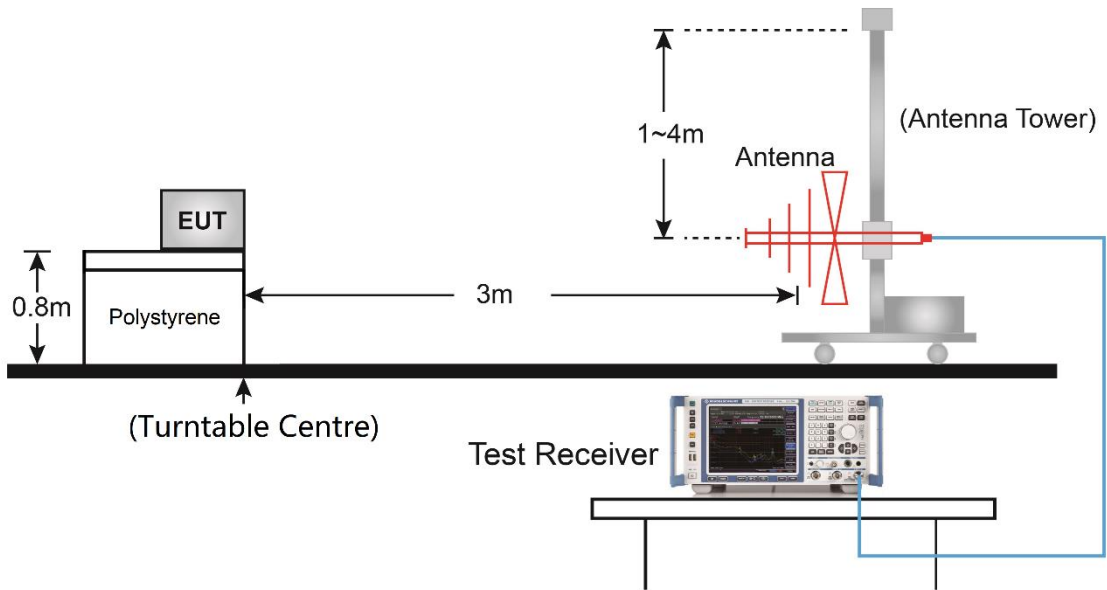

1GHz ~ 18GHz Test Setup:

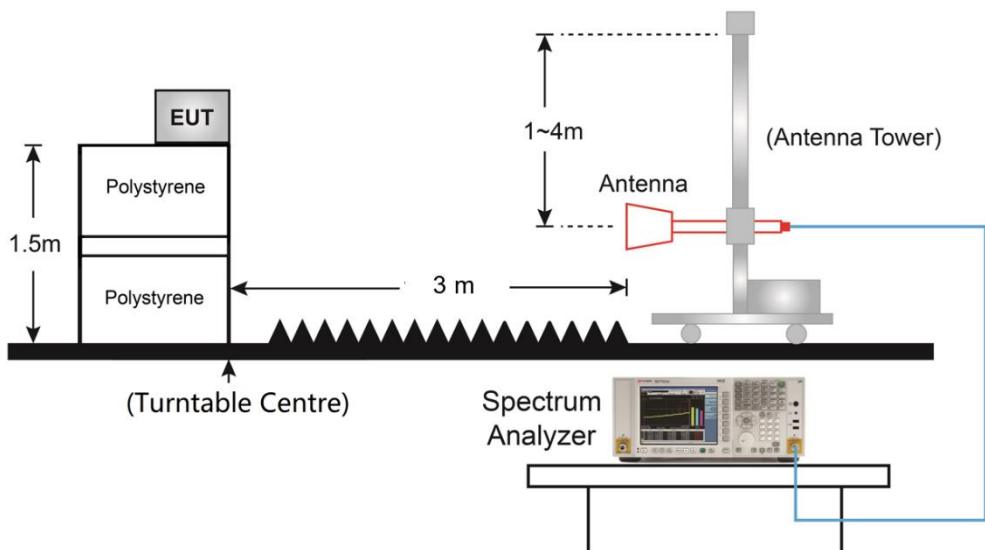

18GHz ~ 50GHz Test Setup:

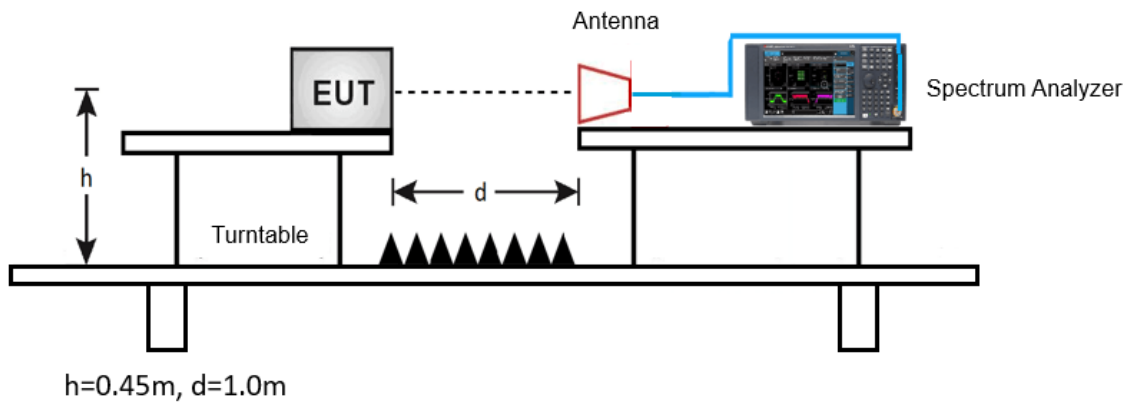

Above 50GHz Test Setup:

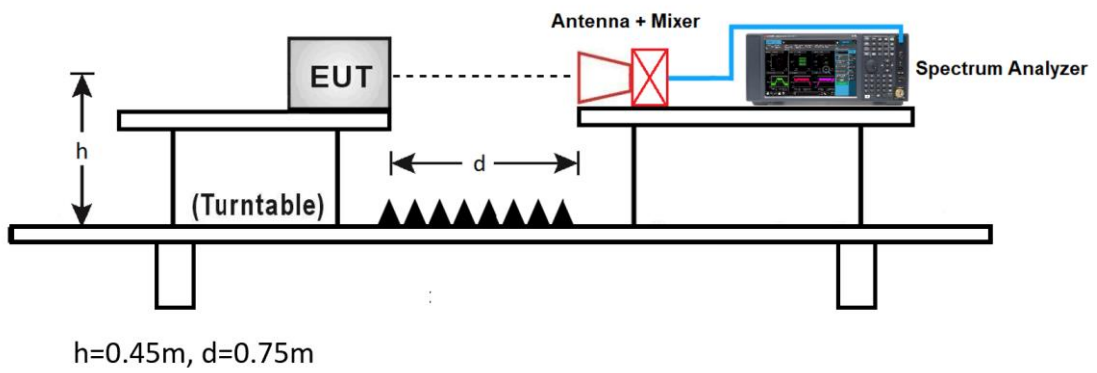

6.3.5. Test Result

Test Site	SIP-TR2	Test Date	2022/04/15
Test Engineer	Chase Zhu	Test Mode	Mode 1

Frequency Band (GHz)	Reading Level (dB μ V)	Factor (dB/m)	Measure Level @1m (dB μ V/m)	Measure Level @3m (dB μ V/m)	Limit (dB μ V/m)	Margin (dB)	Detector	Result
Fundamental Radiated Emission								
24.00 ~ 24.25	83.35	43.28	126.63	117.09	128	-10.91	PK	Pass
	73.66	43.28	116.94	107.40	108	-0.60	AV	Pass

Notes:

- Measure Level (dB μ V/m) = Reading Level (dB μ V) + Factor (dB/m)
Factor (dB/m) = Cable Loss (dB) + Antenna Factor (dB/m)
- The Vertical and Horizontal polarization were evaluated, only the worst-case test results are shown in the table.
- Measure Level @3m = Measure Level @1m + 20 * log(1m / 3m).

Test Site	SIP-AC2	Test Date	2022/04/06
Test Engineer	Allen Zou	Test Mode	Mode 1

Frequency (MHz)	Reading Level (dBμV)	Factor (dB/m)	Measure Level (dBμV/m)	Limit (dBμV/m)	Margin (dB)	Detector	Polarization
Below 1GHz							
167.7	23.4	18.2	41.6	43.5	-1.9	QP	Horizontal
210.0	24.9	15.2	40.1	43.5	-3.4	QP	Horizontal
231.7	25.9	16.4	42.3	46.0	-3.7	QP	Horizontal
259.0	24.8	17.6	42.4	46.0	-3.6	QP	Horizontal
284.6	21.9	18.8	40.7	46.0	-5.3	Peak	Horizontal
546.0	11.6	24.6	36.2	46.0	-9.8	Peak	Horizontal
167.7	17.1	18.2	35.3	43.5	-8.2	Peak	Vertical
232.2	18.7	16.4	35.1	46.0	-10.9	Peak	Vertical
257.5	15.5	17.6	33.1	46.0	-12.9	Peak	Vertical
750.2	12.6	28.6	41.2	46.0	-4.8	Peak	Vertical
750.2	12.6	28.6	41.2	46.0	-4.8	Peak	Vertical
776.5	6.4	28.8	35.2	46.0	-10.8	QP	Vertical

Note:

- Measure Level (dBμV/m) = Reading Level (dBμV) + Factor (dB/m)
Factor (dB/m) = Cable Loss (dB) + Antenna Factor (dB/m)
- The amplitude of radiated emissions (frequency range from 9kHz to 30MHz) is that proximity to ambient noise, which also are attenuated more than 20 dB below the permissible value. Therefore, the data is not presented in the report.
- QP measurement was not performed when peak measure level was lower than the QP limit.

Test Site	SIP-AC2	Test Date	2022/04/18
Test Engineer	Allen Zou	Test Mode	Mode 1

Frequency (MHz)	Reading Level (dBμV)	Factor (dB/m)	Measure Level (dBμV/m)	Limit (dBμV/m)	Margin (dB)	Detector	Polarization
Between 1GHz ~ 18GHz							
7562.0	49.0	-5.9	43.1	74.0	-30.9	Peak	Horizontal
8191.0	49.1	-5.0	44.1	74.0	-29.9	Peak	Horizontal
11480.5	47.1	-2.9	44.2	74.0	-29.8	Peak	Horizontal
7562.0	50.1	-5.9	44.2	74.0	-29.8	Peak	Vertical
8293.0	46.5	-4.8	41.7	74.0	-32.3	Peak	Vertical
11463.5	46.4	-3.1	43.3	74.0	-30.7	Peak	Vertical

Notes:

- Measure Level (dBμV/m) = Reading Level (dBμV) + Factor (dB/m)
 Factor (dB/m) = Cable Loss (dB) + Antenna Factor (dB/m) - Pre-Amplifier Gain (dB)
- Average measurement was not performed when the peak level lower than average limit.

Test Site	SIP-TR2	Test Date	2022/04/15
Test Engineer	Chase Zhu	Test Mode	Mode 1

Frequency (GHz)	Reading Level @0.75m&1m (dB μ V)	Factor (dB/m)	Measure Level @1m (dB μ V/m)	Measure Level @3m (dB μ V/m)	Limit (dB μ V/m)	Margin (dB)	Detector	Result
Between 18 ~ 50GHz								
37.8	36.7	43.3	80.0	70.5	74.0	-3.5	Peak	Pass
37.8	17.1	43.3	60.3	50.8	54.0	-3.2	Average	Pass
48.4	40.1	46.3	86.3	74.3	88.0	-13.7	Peak	Pass
48.4	18.3	46.3	64.5	52.5	68.0	-15.5	Average	Pass

Notes:

- Measure Level (dB μ V/m) = Reading Level (dB μ V) + Factor (dB/m)
 Factor (dB/m) = Cable Loss (dB) + Antenna Factor (dB/m) - Pre-Amplifier Gain (dB)
 Measure Level @3m = Measure Level @1.0m + 20 * log(1m / 3m)
- The Vertical and Horizontal polarization were evaluated, only the worst-case test results are shown in the table.

Frequency (GHz)	Reading Level @0.75m&1m (dB μ V)	Factor (dB/m)	Measure Level @0.75m (dB μ V/m)	Measure Level @3m (dB μ V/m)	Limit (dB μ V/m)	Margin (dB)	Detector	Result
Above 50G								
72.4	44.8	42.7	87.5	75.5	88.0	-12.5	Peak	Pass
72.4	24.0	42.7	66.7	54.7	68.0	-13.3	Average	Pass
96.6	53.2	44.7	97.9	85.8	88.0	-2.2	Peak	Pass
96.6	27.9	44.7	72.6	60.5	68.0	-7.5	Average	Pass

Notes:

- Measure Level (dB μ V/m) = Reading Level (dB μ V) + Factor (dB/m)
 Factor (dB/m) = Cable Loss (dB) + Antenna Factor (dB/m) + Mixer Conversion Loss (dB)
 Measure Level @3m = Measure Level @0.75m + 20 * log(0.75m / 3m)
- The Vertical and Horizontal polarization were evaluated, only the worst-case test results are shown in the table.

6.4. Radiated Restricted Band Edge Measurement

6.4.1. Test Limit

For 15.205 requirement:

Radiated emissions which fall in the restricted bands, as defined in Section 15.205(a) of FCC part 15, must also comply with the radiated emission limits specified in Section 15.209(a).

Frequency (MHz)	Frequency (MHz)	Frequency (MHz)	Frequency (GHz)
0.090 - 0.110	16.42 - 16.423	399.9 - 410	4.5 - 5.15
¹ 0.495 - 0.505	16.69475 - 16.69525	608 - 614	5.35 - 5.46
2.1735 - 2.1905	16.80425 - 16.80475	960 - 1240	7.25 - 7.75
4.125 - 4.128	25.5 - 25.67	1300 - 1427	8.025 - 8.5
4.17725 - 4.17775	37.5 - 38.25	1435 - 1626.5	9.0 - 9.2
4.20725 - 4.20775	73 - 74.6	1645.5 - 1646.5	9.3 - 9.5
6.215 - 6.218	74.8 - 75.2	1660 - 1710	10.6 - 12.7
6.26775 - 6.26825	108 - 121.94	1718.8 - 1722.2	13.25 - 13.4
6.31175 - 6.31225	123 - 138	2200 - 2300	14.47 - 14.5
8.291 - 8.294	149.9 - 150.05	2310 - 2390	15.35 - 16.2
8.362 - 8.366	156.52475 - 156.52525	2483.5 - 2500	17.7 - 21.4
8.37625 - 8.38675	156.7 - 156.9	2690 - 2900	22.01 - 23.12
8.41425 - 8.41475	162.0125 - 167.17	3260 - 3267	23.6 - 24.0
12.29 - 12.293	167.72 - 173.2	3332 - 3339	31.2 - 31.8
12.51975 - 12.52025	240 - 285	3345.8 - 3358	36.43 - 36.5
12.57675 - 12.57725	322 - 335.4	3600 - 4400	(²)
13.36 - 13.41	--	--	--

All out of band emissions appearing in a restricted band as specified in Section 15.205 of the Title 47 CFR must not exceed the limits shown in Table per Section 15.209.

FCC Part 15 Subpart C Paragraph 15.209		
Frequency [MHz]	Field Strength [$\mu\text{V}/\text{m}$]	Measured Distance [Meter]
0.009 ~ 0.490	2400/F (kHz)	300
0.490 ~ 1.705	24000/F (kHz)	30
1.705 ~ 30	30	30
30 ~ 88	100	3
88 ~ 216	150	3
216 ~ 960	200	3
Above 960	500	3

6.4.2. Test Procedure Used

ANSI C63.10-2013 Section 6.3

ANSI C63.10-2013 Section 6.6

ANSI C63.10-2013 Section 6.10

6.4.3. Test Setting

Peak Field Strength Measurements

1. Analyzer center frequency was set to the frequency of the radiated spurious emission of interest
2. RBW = 1MHz
3. VBW = 3MHz
4. Detector = peak
5. Sweep time = auto couple
6. Trace mode = max hold
7. Trace was allowed to stabilize

Average Field Strength Measurements

1. Analyzer center frequency was set to the frequency of the radiated spurious emission of interest
2. RBW = 1MHz
3. VBW $\geq 1/T$
4. As an alternative, the instrument may be set to linear detector mode. Ensure that video filtering is applied in linear voltage domain (rather than in a log or dB domain). Some instruments require linear display mode in order to accomplish this. Others have a setting for Average-VBW Type, which can be set to "Voltage" regardless of the display mode
5. Detector = Peak
6. Sweep time = auto
7. Trace mode = max hold
8. Allow max hold to run for at least 50 times (1/duty cycle) traces

6.4.4. Test Setup

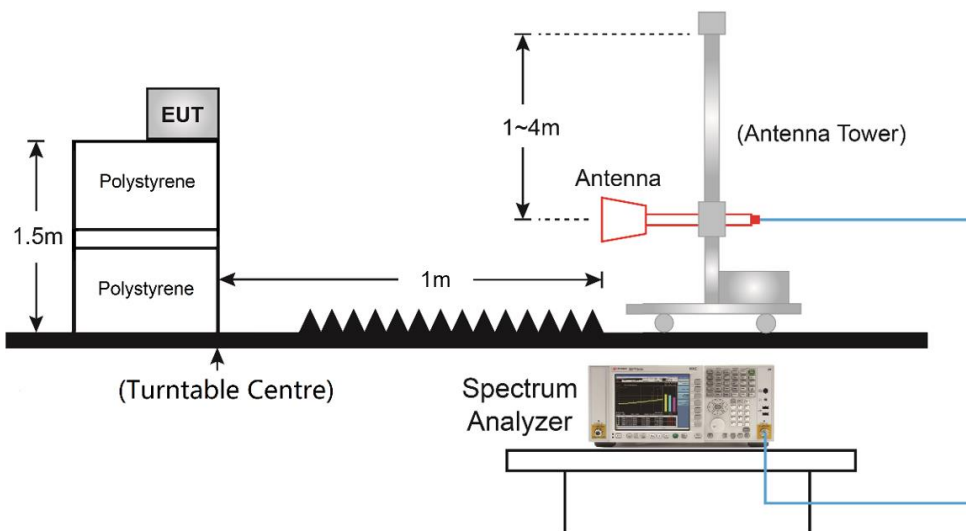

6.4.5. Test Result

Site: SIP-AC2	Test Date: 2022/04/14
Limit: FCC_Part15.209_RE(1m)	Engineer: Allen Zou
Probe: SIP-AC2_BBHA9170_18-40GHz(06598)	Polarity: Horizontal
EUT: Radar	Power: DC 5.8V
Note: Mode 1	

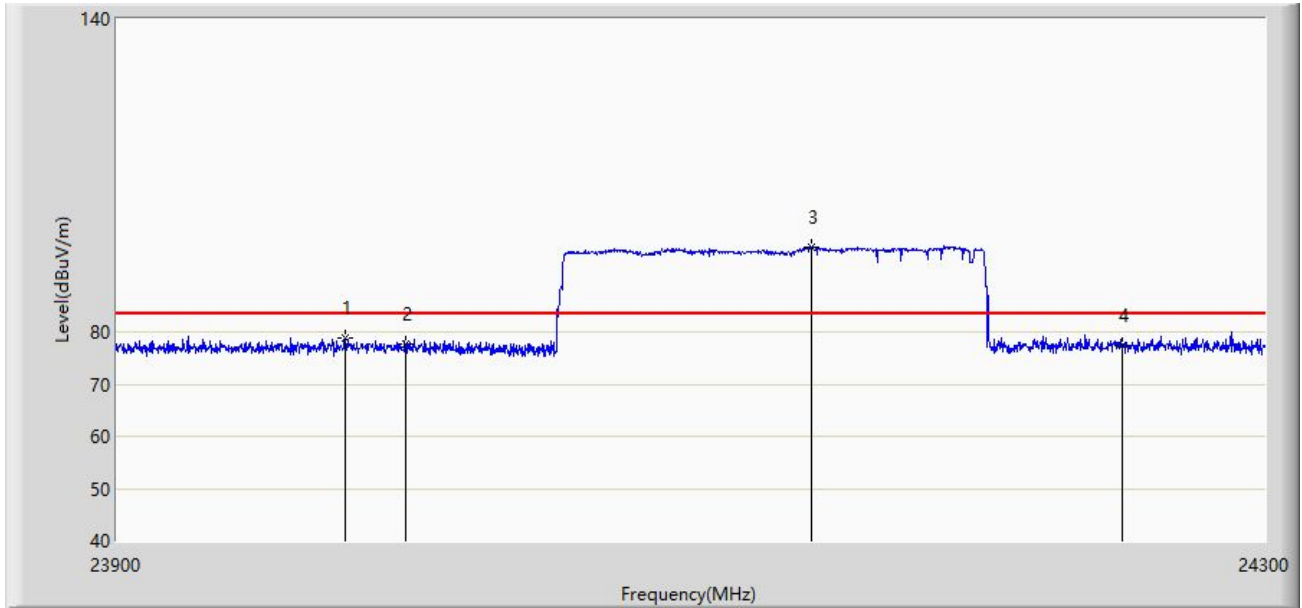

No	Flag	Mark	Frequency (MHz)	Measure Level (dBμV/m)	Reading Level (dBμV)	Margin (dB)	1M Limit (dBμV/m)	Factor (dB/m)	Type
1			23979.400	78.846	36.264	-4.694	83.540	42.582	PK
2			24000.000	77.740	35.209	-5.800	83.540	42.531	PK
3		*	24141.400	96.375	53.694	N/A	N/A	42.681	PK
4			24250.000	77.247	34.295	-6.293	83.540	42.952	PK

Note: Measure Level (dBμV/m) = Reading Level (dBμV) + Factor (dB/m)

Factor (dB/m) = Cable Loss (dB) + Antenna Factor (dB/m) – Pre-Amplifier Gain (dB)

Note 2: Distance limit (d_{limit}) = 3, Distance measured (d_{measured}) = 1

Distance Extrapolation Factor (DEF) = 20 * log (d_{limit} / d_{measured})

1 M Limit (dBμV/m) = 3 M Limit (dBμV/m) + Distance Extrapolation Factor = 3 M Limit (dBμV/m) + 20 * log (d_{limit} / d_{measured})

Site: SIP-AC2	Test Date: 2022/04/14
Limit: FCC_Part15.209_RE(1m)	Engineer: Allen Zou
Probe: SIP-AC2_BBHA9170_18-40GHz(06598)	Polarity: Horizontal
EUT: Radar	Power: DC 5.8V
Note: Mode 1	

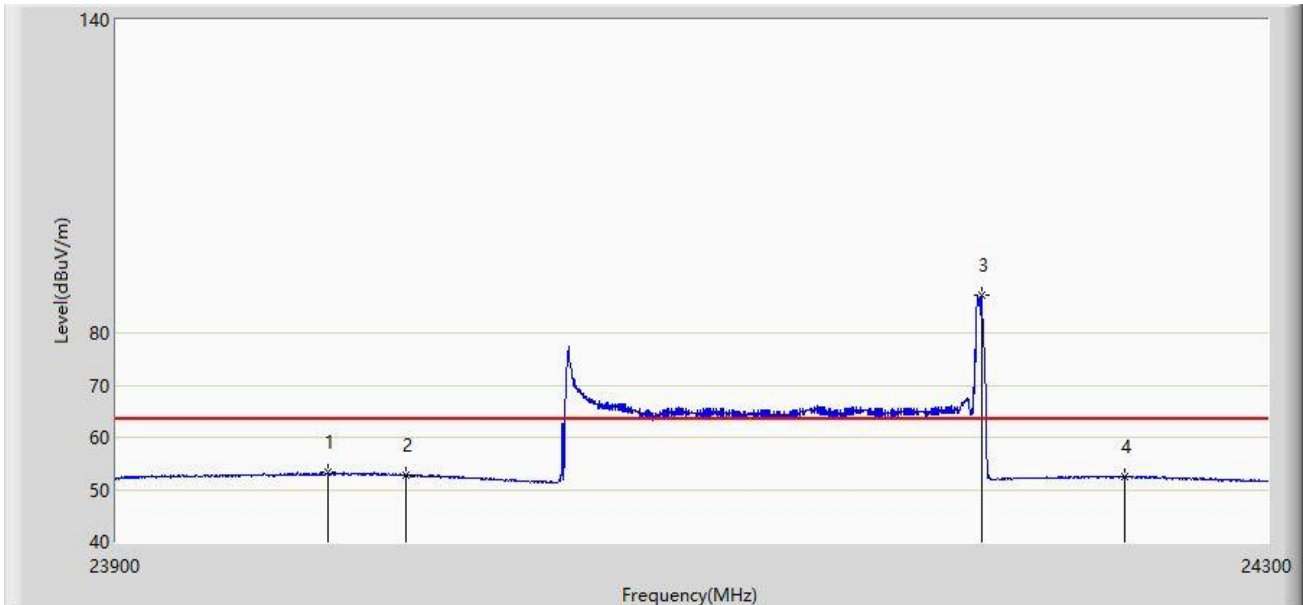

No	Flag	Mark	Frequency (MHz)	Measure Level (dBμV/m)	Reading Level (dBμV)	Margin (dB)	1M Limit (dBμV/m)	Factor (dB/m)	Type
1			23973.199	53.247	10.700	-10.293	63.540	42.547	AV
2			24000.000	52.888	10.357	-10.652	63.540	42.531	AV
3		*	24200.000	87.370	44.482	N/A	N/A	42.888	AV
4			24250.000	52.382	9.430	-11.158	63.540	42.952	AV

Note: Measure Level (dBμV/m) = Reading Level (dBμV) + Factor (dB/m)

Factor (dB/m) = Cable Loss (dB) + Antenna Factor (dB/m) – Pre-Amplifier Gain (dB)

Note 2: Distance limit (d_{limit}) = 3, Distance measured ($d_{measured}$) = 1

Distance Extrapolation Factor (DEF) = $20 * \log (d_{limit} / d_{measured})$

1 M Limit (dBμV/m) = 3 M Limit (dBμV/m) + Distance Extrapolation Factor

Site: SIP-AC2	Test Date: 2022/04/14
Limit: FCC_Part15.209_RE(1m)	Engineer: Allen Zou
Probe: SIP-AC2_BBHA9170_18-40GHz(06598)	Polarity: Vertical
EUT: Radar	Power: DC 5.8V
Note: Mode 1	

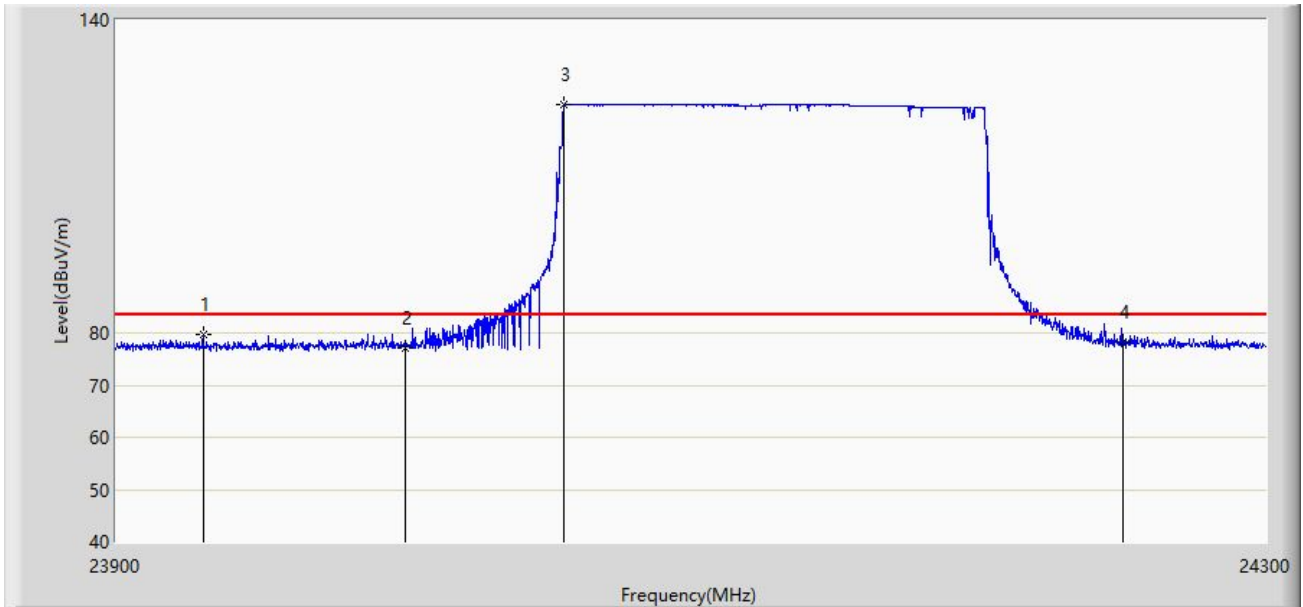

No	Flag	Mark	Frequency (MHz)	Measure Level (dB μ V/m)	Reading Level (dB μ V)	Margin (dB)	1M Limit (dB μ V/m)	Factor (dB/m)	Type
1			23930.199	79.649	37.157	-3.891	83.540	42.493	PK
2			24000.000	77.217	34.686	-6.323	83.540	42.531	PK
3		*	24055.199	123.770	81.408	N/A	N/A	42.361	PK
4			24250.000	78.334	35.382	-5.206	83.540	42.952	PK

Note: Measure Level (dB μ V/m) = Reading Level (dB μ V) + Factor (dB/m)

Factor (dB/m) = Cable Loss (dB) + Antenna Factor (dB/m) – Pre-Amplifier Gain (dB)

Note 2: Distance limit (d_{limit}) = 3, Distance measured ($d_{measured}$) = 1

Distance Extrapolation Factor (DEF) = $20 * \log(d_{limit} / d_{measured})$

1 M Limit (dB μ V/m) = 3 M Limit (dB μ V/m) + Distance Extrapolation Factor

Site: SIP-AC2	Test Date: 2022/04/14
Limit: FCC_Part15.209_RE(1m)	Engineer: Allen Zou
Probe: SIP-AC2_BBHA9170_18-40GHz(06598)	Polarity: Vertical
EUT: Radar	Power: DC 5.8V
Note: Mode 1	

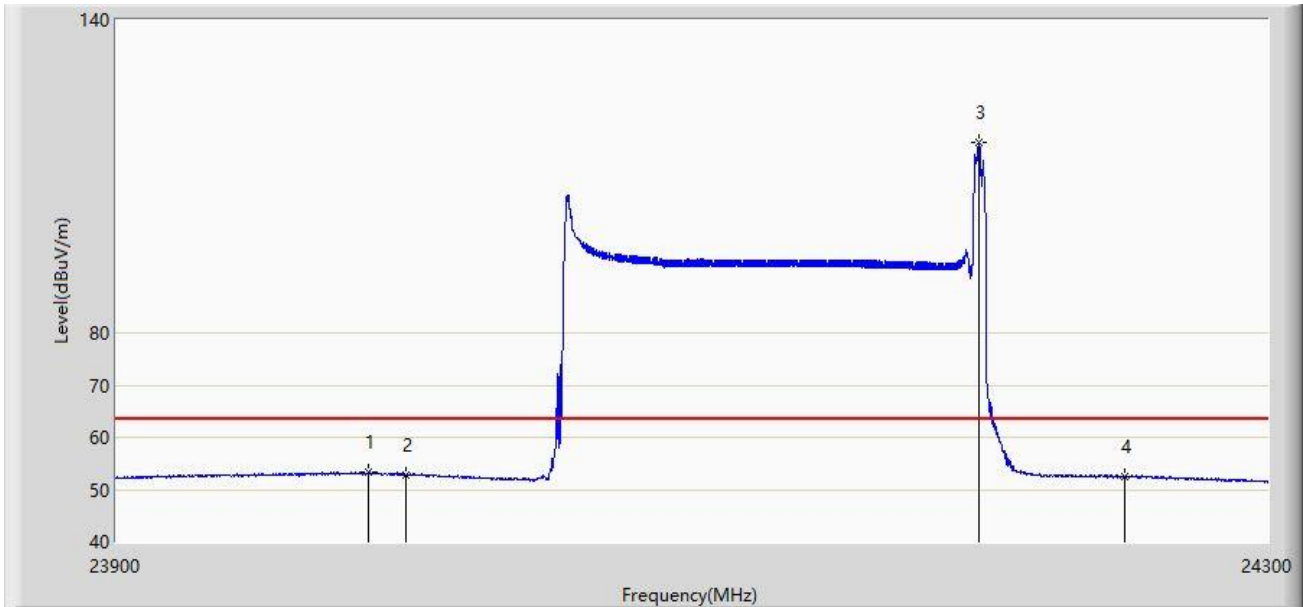

No	Flag	Mark	Frequency (MHz)	Measure Level (dBμV/m)	Reading Level (dBμV)	Margin (dB)	1M Limit (dBμV/m)	Factor (dB/m)	Type
1			23987.000	53.233	10.639	-10.307	63.540	42.594	AV
2			24000.000	52.849	10.318	-10.691	63.540	42.531	AV
3		*	24199.000	116.413	73.535	N/A	N/A	42.877	AV
4			24250.000	52.444	9.492	-11.096	63.540	42.952	AV

Note: Measure Level (dBμV/m) = Reading Level (dBμV) + Factor (dB/m)

Factor (dB/m) = Cable Loss (dB) + Antenna Factor (dB/m) – Pre-Amplifier Gain (dB)

Note 2: Distance limit (d_{limit}) = 3, Distance measured ($d_{measured}$) = 1

Distance Extrapolation Factor (DEF) = $20 * \log(d_{limit} / d_{measured})$

1 M Limit (dBμV/m) = 3 M Limit (dBμV/m) + Distance Extrapolation Factor

6.5. 20dB Spectrum Bandwidth Measurement

6.5.1. Test Limit

Intentional radiators must be designed to ensure that the 20 dB bandwidth of the emission in the specific band.

6.5.2. Test Procedure used

ANSI C63.10-2013 Clause 6.9.2

6.5.3. Test Setting

1. Set the spectrum span range to overlap the nominal center frequency
2. Set RBW = 1% ~ 5% of the OBW
3. VBW $\geq 3 \times$ RBW
4. Detector = Peak
5. Trace mode = max hold
6. Sweep = auto couple
7. Allow the trace to stabilize and marker the highest level
8. Use Occupied BW function to determine two frequencies, one at the lowest frequency and the other at the highest frequency

6.5.4. Test Setup

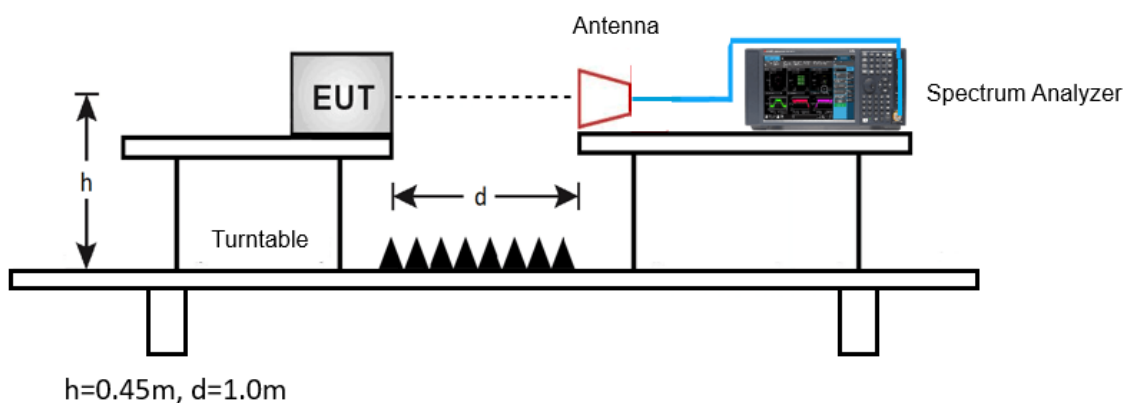

6.5.5. Test Result

Test Site	SIP-TR2	Test Date	2022/04/22
Test Engineer	Chase Zhu		

20dB Bandwidth (MHz)	f _L (MHz)	f _L Limit (MHz)	f _H (MHz)	f _H Limit (MHz)	Result
151.96	24051.535	≥ 24000	24203.493	≤ 24250	Pass

Note: Low Frequency (F_L) F_L = Center Frequency + Lower Boundary;

High Frequency (F_H) F_H = Center Frequency + Upper Boundary

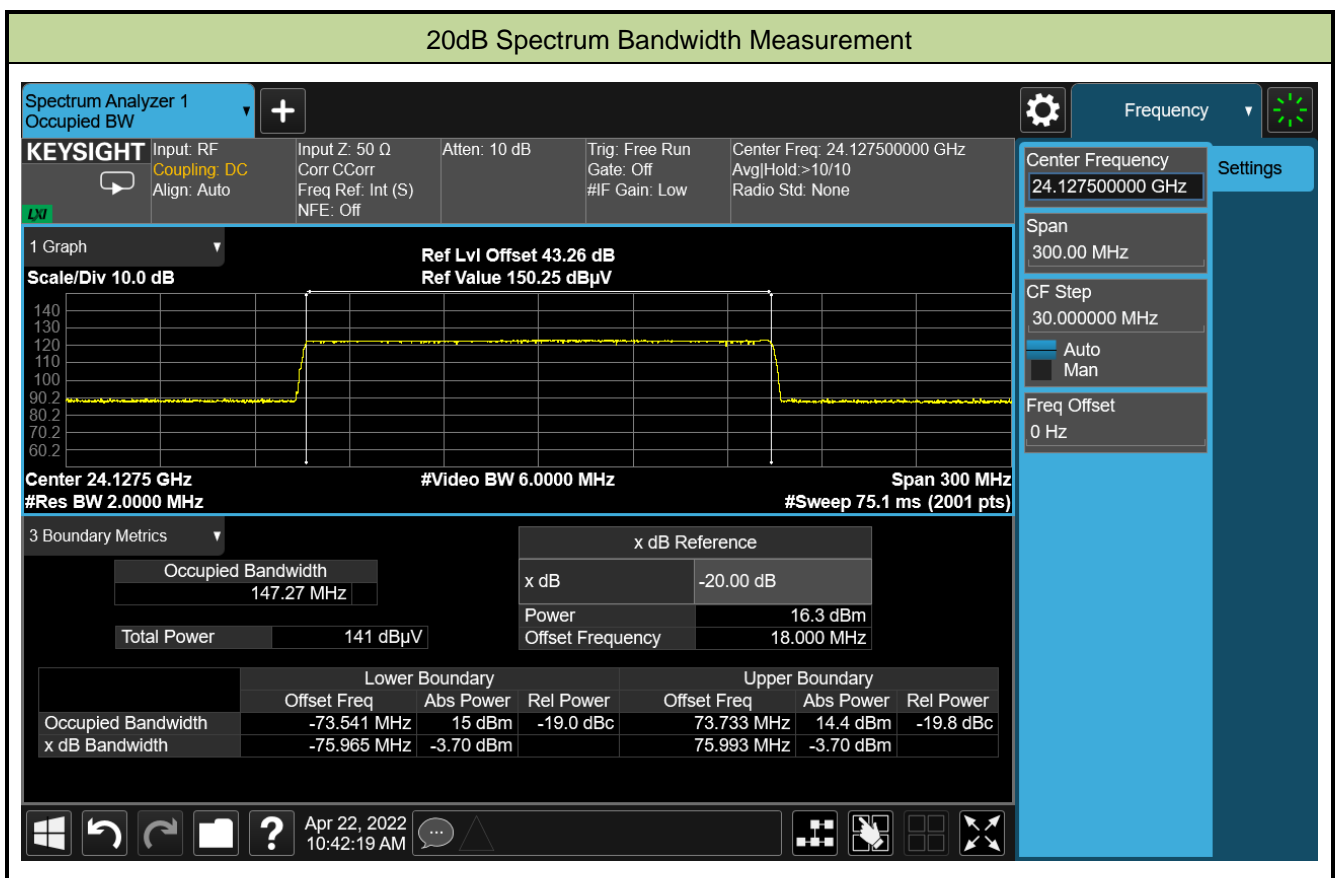

Appendix A - Test Setup Photograph

Refer to "2202RSU040-UT" file.

Appendix B - EUT Photograph

Refer to "2202RSU040-UE" file.