

Guangzhou Xaircraft Technology CO.,LTD

TEST REPORT

SCOPE OF WORK

FCC TESTING-M3DL1A

REPORT NUMBER

240726022SZN-004

ISSUE DATE

31 October 2024

[REVISED DATE]

[-----]

PAGES

26

DOCUMENT CONTROL NUMBER

FCC 15C_Tx_b

© 2017 INTERTEK



RF TEST REPORT

Report No. : 240726022SZN-004
Product : XAG DL1 Data Link
Model No. : M3DL1A
FCC ID : 2A46G-M3DL1A

Applicant: Guangzhou Xaircraft Technology CO.,LTD
Block C, No.115, Gaopu Road, Tianhe District, Guangzhou
City, Guangdong, P.R.China

**Test Method/
Standard:** FCC Part 15 Subpart E;
KDB 789033 D02 v02r01;
KDB 662911 D01 v02r01;
KDB 905462 D02 v02;
ANSI C63.10-2013

Test By: Intertek Testing Services Shenzhen Ltd. Longhua Branch
101, 201, Building B, No. 308 Wuhe Avenue, Zhangkengjing Community,
GuanHu Subdistrict, LongHua District, Shenzhen, P.R. China.

Prepared and Checked by:

Approved by:

Allen Qin
Engineer

Johnny Wang
Project Engineer
Date: 31 October 2024

- The test results reported in this test report shall refer only to the sample actually tested and shall not refer or be deemed to refer to bulk from which such a sample may be said to have been obtained.
- This report is for the exclusive use of Intertek's Client and is provided pursuant to the agreement between Intertek and its Client. Intertek's responsibility and liability are limited to the terms and conditions of the agreement. Intertek assumes no liability to any party, other than to the Client in accordance with the agreement, for any loss, expense or damage occasioned by the use of this report. Only the Client is authorized to copy or distribute this report. Any use of the Intertek name or one of its marks for the sale or advertisement of the tested material, product or service must first be approved in writing by Intertek. The observations and test results referenced from this report are relevant only to the sample tested. This report by itself does not imply that the material, product, or service is or has ever been under an Intertek certification program.
- For Terms And Conditions of the services, it can be provided upon request.
- The evaluation data of the report will be kept for 3 years from the date of issuance.

Intertek Testing Service Shenzhen Ltd. Longhua Branch

101, 201, Building B, No. 308 Wuhe Avenue, Zhangkengjing Community, GuanHu Subdistrict, LongHua District, Shenzhen.
Tel: (86 755) 8601 6288 Fax: (86 755) 8601 6751

Table of Contents

Summary of Tests	3
1. General information	4
1.1 Identification of the EUT	4
1.2 Additional information about the EUT	5
1.3 Antenna description (15.203)	5
1.4 Peripherals equipment.....	5
2. Test specifications	6
2.1 Test standard	6
2.2 Operation mode.....	7
2.3 EUT Exercising Software	8
3. Maximum Output Power test (FCC 15.407)	9
3.1 Operating environment.....	9
3.2 Test setup & procedure	9
3.3 Limit	9
3.4 Measured data of Maximum Output Power test results	9
4. Power Spectrum Density test (FCC 15.407).....	10
4.1 Operating environment.....	10
4.2 Test setup & procedure	10
4.3 Limit	10
4.4 Measured data of Power Spectrum Density test results.....	10
5. Minimum 6 dB RF Bandwidth (FCC 15.407)	11
5.1 Operating environment.....	11
5.2 Test setup & procedure	11
5.3 Limit	12
5.4 Measured data of 6dB down Emission Bandwidth test results.....	12
6. Radiated Emission test (FCC 15.205 & 15.209 & 15.407)	13
6.1 Operating environment.....	13
6.2 Test setup & procedure	13
6.3 Limit	15
6.4 Radiated spurious emission test data	17
6.4.1 Measurement results: frequencies equal to or less than 1 GHz	17
6.4.2 Measurement results: frequency above 1GHz	19
7. Power Line Conducted Emission test	21
7.1 Operating environment.....	21
7.2 Test setup & procedure	21
7.3 Limit	21
7.4 Power Line Conducted Emission test data	22
8. Frequency Stability Test	24
8.1 Test setup & procedure	24
8.2 Frequency Stability Test Data.....	25

Summary of Tests

FCC Parts	Test	Section	Results
15.203	Antenna Requirement	1.3	Pass
15.407 a (1)/(3)	Maximum output power test	3	Pass
15.407 a (1)/(3)	Power Spectrum Density test	4	Pass
15.407 e	6dB Bandwidth	5	Pass
15.407 b, 15.205, 15.209	Radiated spurious emission test	6	Pass
15.207	AC line conducted emission test	7	Pass
15.407 g	Frequency Stability	8	Pass

1. General information

1.1 Identification of the EUT

Product:	XAG DL1 Data Link
Model No.:	M3DL1A
Type of Device:	Master device
Nominal Channel Bandwidth:	802.11a/n-HT20(20MHz)
Frequency range:	5725MHz~5850MHz
Channel Number and Operating Frequency:	5 channels for 5745 MHz ~ 5825 MHz (802.11a/n20-HT20);
Modulation:	802.11a: OFDM (BPSK, QPSK, 16QAM, 64QAM) 802.11n: OFDM (BPSK, QPSK, 16QAM, 64QAM)
Rated Power:	DC 3.65 V from rechargeable battery
Test Date(s):	26 July 2024 to 08 October 2024

Note 1: This report is for the exclusive use of Intertek's Client and is provided pursuant to the agreement between Intertek and its Client. Intertek's responsibility and liability are limited to the terms and conditions of the agreement. Intertek assumes no liability to any party, other than to the Client in accordance with the agreement, for any loss, expense or damage occasioned by the use of this report. Only the Client is authorized to permit copying or distribution of this report and then only in its entirety. Any use of the Intertek name or one of its marks for the sale or advertisement of the tested material, product or service must first be approved in writing by Intertek. The observations and test results in this report are relevant only to the sample tested. This report by itself does not imply that the material, product, or service is or has ever been under an Intertek certification program.

Note 2: When determining the test conclusion, the Measurement Uncertainty of test has been considered.

1.2 Additional information about the EUT

The equipment under test (EUT) is a XAG DL1 Data Link with Bluetooth 5.0 (dual-mode) function operating in 2402-2480MHz, 2.4G WIFI function operating in 2412-2462MHz and 5G WIFI function operating in 5725MHz~5850MHz. The EUT is powered by DC 3.65 V from rechargeable battery. For more detail information pls. refer to the user manual.

For more detail features, please refer to User's description as file name "descri.pdf".

Related Submittal(s) Grants

This is an application for certification of U–NII device (5GHz Wi-Fi transmitter portion).

For the BT BLE function was tested and demonstrated in report 240726022SZN-002.

For the 2.4GHz WIFI function was tested and demonstrated in report 240726022SZN-003.

1.3 Antenna description (15.203)

The EUT uses PCB Antenna which in accordance to Section 15.203 is considered sufficient to comply with the provisions of this section.

Antenna0 Gain: 3.7 dBi Max for 5G WIFI.

Antenna1 Gain: 3.7 dBi Max for 5G WIFI.

Antenna2 Gain: 5.87 dBi Max for 5G WIFI.

Antenna3 Gain: 5.87 dBi Max for 5G WIFI.

MIMO Gain: 10.87 dBi Max for 5G WIFI.

1.4 Peripherals equipment

Description	Manufacturer	Remark
C to C Cable (Provided by Applicant)	N/A	un-shielded, 100cm
Adaptor (Provided by Intertek)	GS	MODEL: GS-W30A0936 Input:100-240V~50/60Hz, 0.8A Output:DC 5V 3A, 9V 3A, 12V 2.5A, 15V 2A

2. Test specifications

2.1 Test standard

The EUT was performed according to the procedures in FCC Part 15 E, Section 15.203, 15.207, 15.209, 15.407 and ANSI C63.10/2013, method of measurement: KDB 789033.

The test of radiated measurements according to FCC Part 15 Section 15.33(a) had been conducted and the field strength of this frequency band was all meet limit requirement, thus we evaluate the EUT pass the specified test.

The AC power conducted emissions was investigated over the frequency range from 0.15 MHz to 30 MHz using a receiver bandwidth of 9 kHz (15.207 paragraph).

Radiated emissions were investigated cover the frequency range from 9KHz to 30MHz using a receiver RBW of 9kHz, from 30 MHz to 1000 MHz using a receiver RBW of 120 kHz record QP reading, and the frequency over 1 GHz using a spectrum analyzer RBW of 1 MHz, VBW of 3MHz, Detector=Peak record for Peak reading, RBW of 1 MHz, VBW of 3MHz, Detector=RMS record for Average reading recorded on the report.

The EUT setup configurations please refer to the photo of radiated setup photos.pdf & conducted setup photos.pdf.

2.2 Operation mode

The EUT was supplied by and it was run in TX mode that was controlled by client provided RF testing program.

The EUT was transmitted continuously during the test. The worst case test result was showed in the report.

With individual verifying, the maximum output power was found at 6 Mbps data rate for 802.11a mode, 6.5 Mbps data rate for 802.11n-HT20 mode. The final tests were executed under these conditions and recorded in this report individually.

2.3 EUT Exercising Software

The EUT exercise program (provided by client) used during radiated and conducted testing was designed to exercise the various system components in a manner similar to a typical use. The worst case configuration is used in all specified testing.

Table for Parameters of Test Software Setting

During testing, Channel & Power Controlling Software provided by the customer was used to control the operating channel as well as the output power level. The RF output power selection is for the setting of RF output power expected by the customer and is going to be fixed on the firmware of the final end product.

Test software: QSPR

3. Maximum Output Power test (FCC 15.407)

3.1 Operating environment

Temperature: 25 °C
Relative Humidity: 55 %
Atmospheric Pressure: 1011 hPa

3.2 Test setup & procedure

The power output per FCC §15.407(a) was measured on the EUT using a 50 ohm SMA cable connected to Average Power Meter and the measurement method refer to 789033 D02. Power was read directly and cable loss correction (0.5dB) was added to the reading to obtain power at the EUT antenna terminals.

Block Diagram:

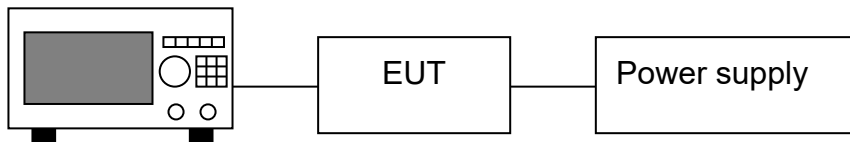

Power meter

3.3 Limit

Frequency range (MHz)	Max Conducted TX Power	Max EIRP
5725~5850	30dBm (1W)	4W (36dBm) with 6dBi antenna

- Remark:
- 1) *Where B is the 26dB emission Bandwidth in MHz.
 - 2) The device was declared as Master device.
 - 3) Tx Power Reduction (dBm-by-dBi) required when antenna exceeds 6dBi.

3.4 Measured data of Maximum Output Power test results

Max Conducted TX Power

The more detail please refer to “Appendix of 240726022SZN-004” Appendix D.

4. Power Spectrum Density test (FCC 15.407)

4.1 Operating environment

Temperature: 25 °C
Relative Humidity: 50 %
Atmospheric Pressure: 1013 hPa

4.2 Test setup & procedure

Method of Measurement:

The power spectrum density per FCC §15.407(a) was measured from the antenna port of the EUT using a 50 ohm spectrum analyzer with the resolution bandwidth set at 1MHz/500KHz, the video bandwidth set at 3 MHz/2MHz (measurement method refer to KDB 789033 D02). Power spectrum density was read directly and cable loss reading to obtain power at the EUT antenna terminals.

Block Diagram:

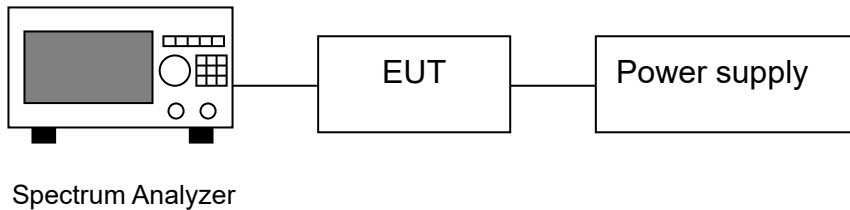

4.3 Limit

Frequency range(MHz)	Max Conducted Power Spectral Density
5150~5250	*17dBm/MHz for master device
	11dBm/MHz for mobile/portable client device
5250~5350	11dBm/MHz
5470~5725	11dBm/MHz
5725~5850	30dBm/500KHz

Remark: 1) The device was declared as Master device.
2) Tx Power Reduction (dBm-by-dBi) required when antenna exceeds 6dBi.

4.4 Measured data of Power Spectrum Density test results

The more detail please refer to “Appendix of 240726022SZN-004” Appendix E.

5. Minimum 6 dB RF Bandwidth (FCC 15.407)

5.1 Operating environment

Temperature: 25 °C
Relative Humidity: 50 %
Atmospheric Pressure: 1011 hPa

5.2 Test setup & procedure

The Minimum 6 dB RF Bandwidth per 789033 D02 was measured from the antenna port of the EUT using a 50 ohm spectrum analyzer with the resolution bandwidth set at 100KHz, and set the video bandwidth (VBW) $\geq 3 \times$ RBW. For each RF output channel investigated, the spectrum analyzer center frequency was set to the channel carrier. A PEAK output reading was taken, a DISPLAY line was drawn 6 dB lower than PEAK level. The 6dB bandwidth was determined from where the channel output spectrum intersected the display line.

For 26dB down Emission Bandwidth

The 26dB down Emission Bandwidth per 789033 D02 was measured from the antenna port of the EUT using a 50 ohm spectrum analyzer with the resolution bandwidth set RBW = approximately 1% of the emission bandwidth. Set the VBW > RBW, Detector = Peak, Trace mode = max hold (Measure the maximum width of the emission that is 26 dB down from the maximum of the emission. Compare this with the RBW setting of the analyzer. Readjust RBW and repeat measurement as needed until the RBW/EBW ratio is approximately 1%).

For 99% Occupied Bandwidth

The 99% Occupied Bandwidth per 789033 D02 was measured from the antenna port of the EUT using a 50 ohm spectrum analyzer with the resolution bandwidth set center frequency to the nominal EUT channel center frequency, set span = 1.5 times to 5.0 times the OBW, set RBW = 1 % to 5 % of the OBW, set VBW $\geq 3 \times$ RBW, The 99% occupied bandwidth was determined from where the channel output spectrum intersected the display line.

Block Diagram:

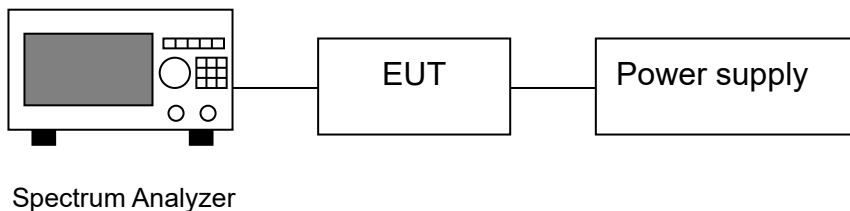

5.3 Limit

Frequency range(MHz)	Minimum 6 dB RF Bandwidth Limit
5150~5250	N/A
5250~5350	N/A
5470~5725	N/A
5725~ 5850	≥500KHz

5.4 Measured data of 6dB down Emission Bandwidth test results

The more detail please refer to “Appendix of 240726022SZN-004” Appendix C.

Note: 99% Occupied Bandwidth within the U-NII band and 26dB Emission Bandwidth for reference. The more detail please refer to “Appendix of 240726022SZN-004” Appendix B and Appendix A.

6. Radiated Emission test (FCC 15.205 & 15.209 & 15.407)

6.1 Operating environment

Temperature:	23	°C
Relative Humidity:	56	%
Atmospheric Pressure	1011	hPa

6.2 Test setup & procedure

The Diagram below shows the test setup, which is utilized to make these measurements.

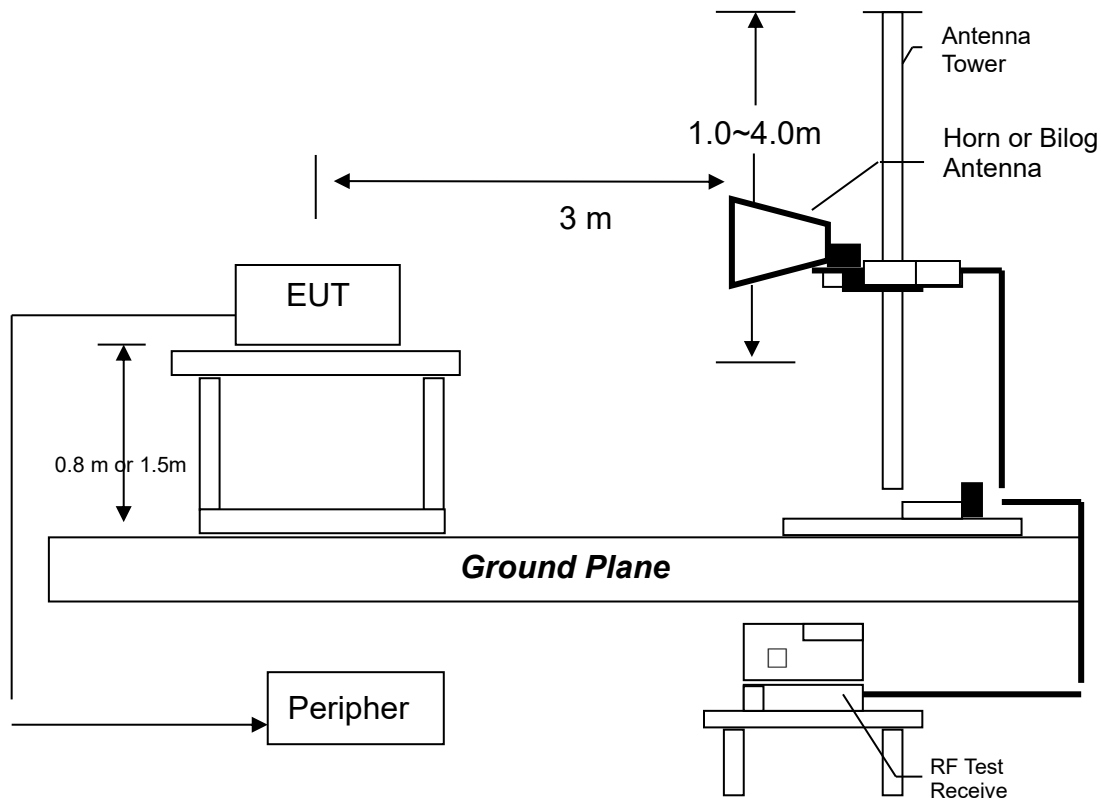

Radiated emission measurements were performed from 9KHz to tenth harmonic or 40GHz.

The EUT for testing is arranged on a styrene turntable with the height of 0.8m up to 1GHz and 1.5m above 1GHz. If some peripherals apply to the EUT, the peripherals will be connected to EUT and the whole system. During the test, all cables were arranged to produce worst-case emissions. The signal is maximized through rotation. The height of antenna and polarization is changing constantly for exploring for maximum signal level. The height of antenna can be up to 4 meters and down to 1 meter.

The measurement for radiated emission will be done at the distance of three meters unless the signal level is too low to measure at that distance. In the case of the reading under noise floor, a pre-amplifier is used and/or the test is conducted at a closer distance. And then all readings are extrapolated back to the equivalent three meter reading using inverse scaling with distance.

Testing settings (refer to KDB 789033 D02)

Peak Measurements below 1GHz

- 1, Analyzer center frequency was set to the frequency of the radiated spurious emission.
- 2, Span=encompass the entire emission
- 3, RBW=120KHz
- 4, Detector=Quasi-Peak
- 5, Trace was allowed to stabilize

Peak Measurements above 1GHz

- 1, Analyzer center frequency was set to the frequency of the radiated spurious emission.
- 2, Span=encompass the entire emission
- 3, RBW=1MHz
- 4, VBW=3MHz
- 4, Detector= Peak (Max-hold)
- 5, Trace was allowed to stabilize

Average Measurements above 1GHz

- 1, Analyzer center frequency was set to the frequency of the radiated spurious emission.
- 2, Span=encompass the entire emission
- 3, RBW=1MHz
- 4, VBW=3MHz
- 4, Detector= RMS (Max-hold)
- 5, Trace was allowed to stabilize

6.3 Limit

The spurious Emission shall test through the 10th harmonic or 40GHz (whichever is lower). In addition, radiated emissions which fall in the restricted bands, as defined in §15.205(a), must also comply with the radiated emission limits specified in §15.209(a).

Notes:

- 1, All emission out-side of the 5.15-5.35GHz & 5.47-5.725GHz band shall not exceed an EIRP of -27dBm/MHz (68.2dBuV/m, test distance: 3 meter), For the band 5.725-5.85GHz, all emissions shall be limited to a level of -27 dBm/MHz at 75 MHz or more above or below the band edge increasing linearly to 10 dBm/MHz at 25 MHz above or below the band edge, and from 25 MHz above or below the band edge increasing linearly to a level of 15.6 dBm/MHz at 5 MHz above or below the band edge, and from 5 MHz above or below the band edge increasing linearly to a level of 27 dBm/MHz at the band edge.
- 2, The spectrum is measured from 9KHz to the 10th harmonic of the fundamental frequency of the transmitter using QP detector below 1GHz, above 1GHz, average & peak measurements were taken using for test. The worst-case emission are reported however emission whose levels were not within 20dB of the respective limited were not reported.
- 3, The test was performed on EUT under 802.11a/n-HT20 continuously transmitting mode. Simultaneous transmitting was considered during the testing. All mode had been tested, but only the worst-case is recorded in the following graph and table.

6.3.1 Field Strength Calculation

The field strength is calculated by adding the reading on the Spectrum Analyzer to the factors associated with preamplifiers (if any), antennas, cables, pulse desensitization and average factors (when specified limit is in average and measurements are made with peak detectors). A sample calculation is included below.

$$FS = RA + AF + CF - AG + PD$$

Where

- FS = Field Strength in dB μ V/m
- RA = Receiver Amplitude (including preamplifier) in dB μ V
- CF = Cable Attenuation Factor in dB
- AF = Antenna Factor in dB
- AG = Amplifier Gain in dB
- PD = Pulse Desensitization in dB

In the radiated emission table which follows, the reading shown on the data table may reflect the preamplifier gain. An example of the calculations, where the reading does not reflect the preamplifier gain, follows:

$$FS = RA + AF + CF - AG + PD$$

Example

Assume a receiver reading of 62.0 dB μ V is obtained. The antenna factor of 7.4 dB and cable factor of 1.6 dB is added. The amplifier gain of 29 dB is subtracted. The pulse desensitization factor of the spectrum analyzer was 0 dB. The net field strength for comparison to the appropriate emission limit is 32 dB μ V/m. This value in dB μ V/m was converted to its corresponding level in μ V/m.

$$\begin{aligned} RA &= 62.0 \text{ dB}\mu\text{V} \\ AF &= 7.4 \text{ dB} \\ CF &= 1.6 \text{ dB} \\ AG &= 29.0 \text{ dB} \\ PD &= 0 \text{ dB} \\ FS &= 62 + 7.4 + 1.6 - 29 + 0 = 42 \text{ dB}\mu\text{V/m} \end{aligned}$$

$$\text{Level in mV/m} = \text{Common Antilogarithm} [(42 \text{ dB}\mu\text{V/m})/20] = 125.9 \mu\text{V/m}$$

6.4 Radiated spurious emission test data

6.4.1 Measurement results: frequencies equal to or less than 1 GHz

Applicant: Guangzhou Xaircraft Technology CO.,LTD

Date of Test: 07 September 2024

Model: M3DL1A

Worst Case Operating Mode: Simulation transmission

Radiated Emissions

ANT Polarity: Horizontal

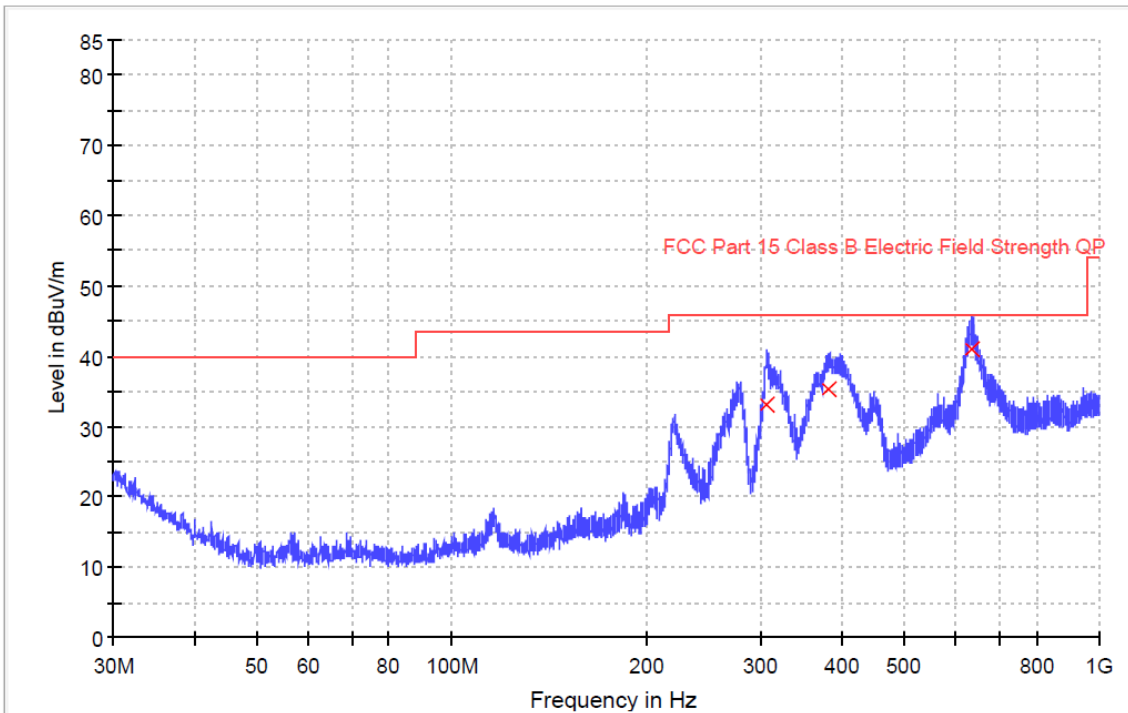

Frequency (MHz)	QuasiPeak (dBuV/m)	Meas. Time (ms)	Bandwidth (kHz)	Polarization	Corr. (dB/m)	Margin - QPK (dB)	Limit - QPK (dBuV/m)
307.193667	33.2	1000.0	120.000	H	20.6	12.8	46.0
380.946000	35.2	1000.0	120.000	H	24.5	10.8	46.0
636.120667	41.0	1000.0	120.000	H	29.4	5.0	46.0

NOTES:

1. Quasi-Peak detector is used for frequency below 1GHz.
2. All measurements were made at 3 meters. Harmonic emissions not detected at the 3-meter distances were measured at 0.3-meter and an inverse proportional extrapolation was performed to compare the signal level to the 3-meter limit. No other harmonic emissions than those reported were detected at a test distance of 0.3-meter.
3. Negative value in the margin column shows emission below limit.
4. All emissions are below the QP limit.

Applicant: Guangzhou Xaircraft Technology CO.,LTD
 Date of Test: 07 September 2024 Model: M3DL1A
 Worst Case Operating Mode: Simulation transmission

Radiated Emissions

ANT Polarity: Vertical

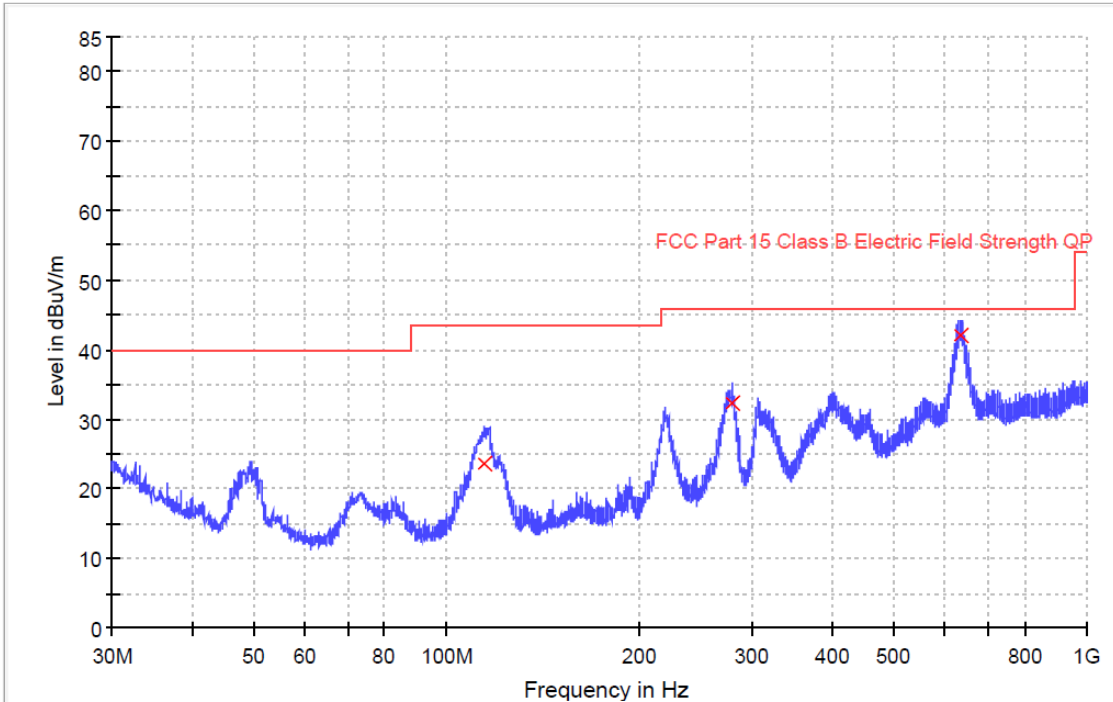

Frequency (MHz)	QuasiPeak (dBuV/m)	Meas. Time (ms)	Bandwidth (kHz)	Polarization	Corr. (dB/m)	Margin - QPK (dB)	Limit - QPK (dBuV/m)
114.648667	23.5	1000.0	120.000	V	14.7	20.0	43.5
279.354667	32.3	1000.0	120.000	V	19.9	13.7	46.0
637.672667	42.1	1000.0	120.000	V	29.4	3.9	46.0

NOTES:

1. Quasi-Peak detector is used for frequency below 1GHz.
2. All measurements were made at 3 meters. Harmonic emissions not detected at the 3-meter distances were measured at 0.3-meter and an inverse proportional extrapolation was performed to compare the signal level to the 3-meter limit. No other harmonic emissions than those reported were detected at a test distance of 0.3-meter.
3. Negative value in the margin column shows emission below limit.
4. All emissions are below the QP limit.

6.4.2 Measurement results: frequency above 1GHz

The worst case occurred at 802.11a

Channel 149/6 Mbps

Polarization	Frequency (MHz)	Reading (dBμV)	Pre-Amp Gain (dB)	Antenna Factor (dB)	Net at 3m (dBμV/m)	Peak Limit at 3m (dBμV/m)	Margin (dB)
Horizontal	11490.000	46.3	36.3	38.9	48.9	68.2	-19.3
Horizontal	17235.000	49.9	34.7	41.0	56.2	68.2	-12.0

Polarization	Frequency (MHz)	Reading (dBμV)	Pre-Amp Gain (dB)	Antenna Factor (dB)	Net at 3m (dBμV/m)	Average Limit at 3m (dBμV/m)	Margin (dB)
Horizontal	11490.000	37.7	36.3	38.9	40.3	54.0	-13.7
Horizontal	17235.000	40.4	34.7	41.0	46.7	54.0	-7.3

Channel 157/6Mbps

Polarization	Frequency (MHz)	Reading (dBμV)	Pre-Amp Gain (dB)	Antenna Factor (dB)	Net at 3m (dBμV/m)	Peak Limit at 3m (dBμV/m)	Margin (dB)
Horizontal	11570.000	47.0	36.3	38.9	49.6	68.2	-18.6
Horizontal	17325.000	50.0	34.7	41.0	56.3	68.2	-11.9

Polarization	Frequency (MHz)	Reading (dBμV)	Pre-Amp Gain (dB)	Antenna Factor (dB)	Net at 3m (dBμV/m)	Average Limit at 3m (dBμV/m)	Margin (dB)
Horizontal	11570.000	38.3	36.3	38.9	40.9	54.0	-13.1
Horizontal	17325.000	39.0	34.7	41.0	45.3	54.0	-8.7

Channel 165/6Mbps

Polarization	Frequency (MHz)	Reading (dBμV)	Pre-Amp Gain (dB)	Antenna Factor (dB)	Net at 3m (dBμV/m)	Peak Limit at 3m (dBμV/m)	Margin (dB)
Horizontal	11650.000	47.7	36.3	38.9	50.3	68.2	-17.9
Horizontal	17475.000	50.4	34.7	41.0	56.7	68.2	-11.5

Polarization	Frequency (MHz)	Reading (dBμV)	Pre-Amp Gain (dB)	Antenna Factor (dB)	Net at 3m (dBμV/m)	Average Limit at 3m (dBμV/m)	Margin (dB)
Horizontal	11650.000	38.5	36.3	38.9	41.1	54.0	-12.9
Horizontal	17475.000	40.5	34.7	41.0	46.8	54.0	-7.2

- * Emission within the restricted band meets the requirement of section 15.205. The corresponding limit as per 15.209 is based on Quasi peak limit for frequencies below 1000 MHz and average limit for frequencies over 1000 MHz. The radio frequency emissions above 1GHz also meet corresponding 20dB permitted peak limit with a peak detector function. All unwanted emissions outside of the 5.15-5.35GHz & 5.47-5.725GHz & 5725-5850 bands are complied with the limit.

7. Power Line Conducted Emission test

7.1 Operating environment

Temperature:	24	°C
Relative Humidity:	55	%
Atmospheric Pressure	1011	hPa

7.2 Test setup & procedure

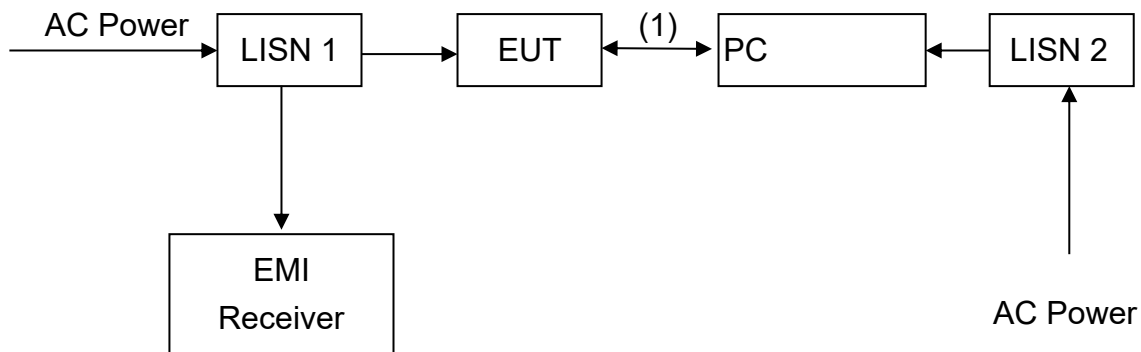

The EUT are connected to the main power through a line impedance stabilization network (LISN). This provides a 50 ohm/50 uH coupling impedance for the measuring equipment. The peripheral devices are also connected to the main power through a LISN that provides a 50 ohm/50 uH coupling impedance with 50 ohm termination.

Both sides (Line and Neutral) of AC line are checked for maximum conducted interference. In order to find the maximum emission, the relative positions of equipment and all of the interface cables must be changed according to ANSI C63.10/2013 on conducted measurement.

The bandwidth of the field strength meter (R & S Test Receiver ESCI 30) is set at 9 kHz.

7.3 Limit

Frequency (MHz)	Conducted Limit (dBuV)	
	Q.P.	Ave.
0.15~0.50	66 – 56*	56 – 46*
0.50~5.00	56	46
5.00~30.0	60	50

*Decreases with the logarithm of the frequency.

7.4 Power Line Conducted Emission test data

Applicant: Guangzhou Xaircraft Technology CO.,LTD

Date of Test: 04 September 2024

Worst Case Operating Mode:

Phase: Live

Model: M3DL1A

Transmit (5745MHz)

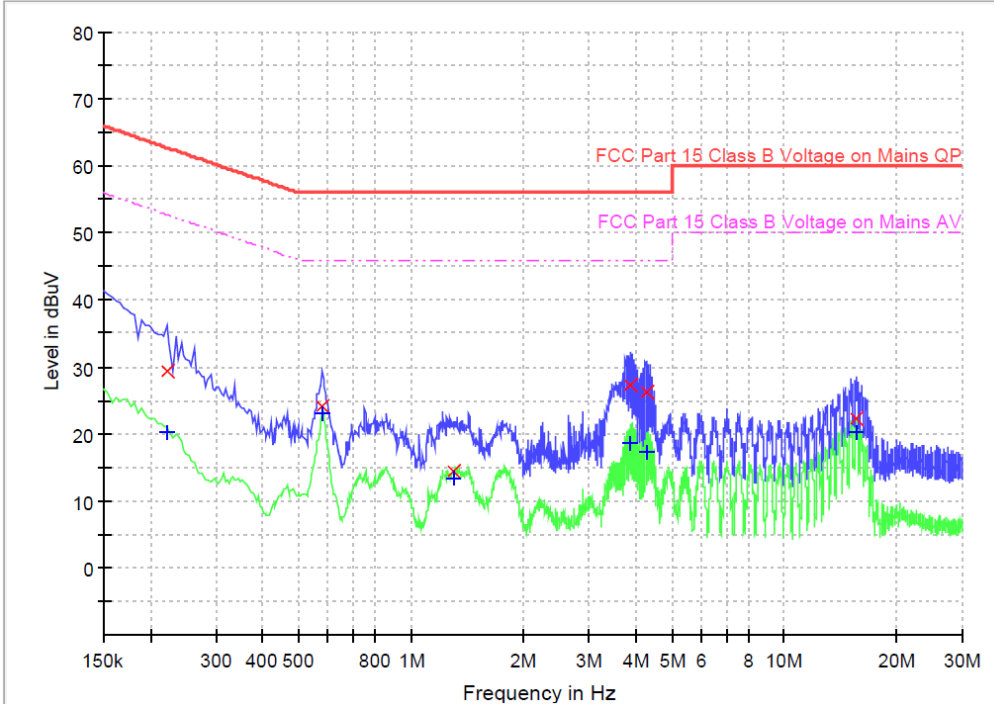

Limit and Margin QP

Frequency (MHz)	Quasi Peak (dB μ V)	Bandwidth (kHz)	Line	Corr. (dB)	Margin (dB)	Limit (dB μ V)
0.222000	29.3	9.000	L1	9.6	33.4	62.7
0.578000	24.1	9.000	L1	9.6	31.9	56.0
1.298000	14.5	9.000	L1	9.6	41.5	56.0
3.874000	27.2	9.000	L1	9.7	28.8	56.0
4.266000	26.3	9.000	L1	9.7	29.7	56.0
15.566000	22.2	9.000	L1	10.4	37.8	60.0

Limit and Margin AV

Frequency (MHz)	Average (dBuV)	Bandwidth (kHz)	Line	Corr. (dB)	Margin (dB)	Limit (dBuV)
0.222000	20.3	9.000	L1	9.6	32.4	52.7
0.578000	23.1	9.000	L1	9.6	22.9	46.0
1.298000	13.2	9.000	L1	9.6	32.8	46.0
3.874000	18.6	9.000	L1	9.7	27.4	46.0
4.266000	17.3	9.000	L1	9.7	28.7	46.0
15.566000	20.3	9.000	L1	10.4	29.7	50.0

Remark:

1. Corr. Factor (dB) = LISN Factor (dB) + Cable Loss (dB)
2. Margin (dB) = Limit (dBuV) – Level (dBuV)

Applicant: Guangzhou Xaircraft Technology CO.,LTD
Date of Test: 04 September 2024
Worst Case Operating Mode:
Phase: Neutral

Model: M3DL1A
Transmit (5745MHz)

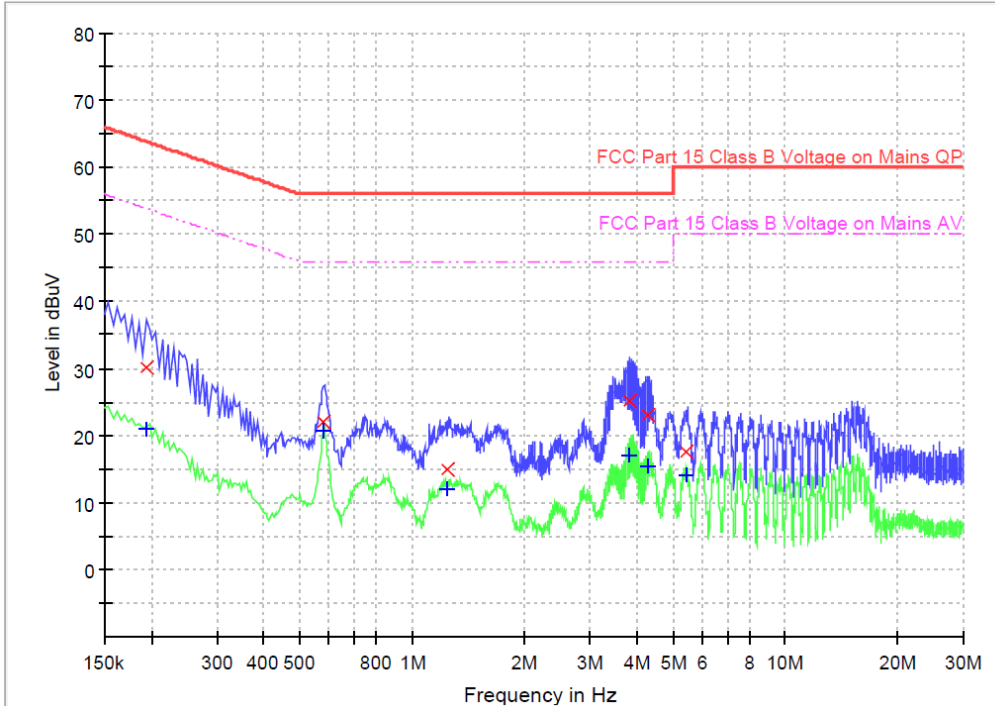

Limit and Margin QP

Frequency (MHz)	Quasi Peak (dBμV)	Bandwidth (kHz)	Line	Corr. (dB)	Margin (dB)	Limit (dBμV)
0.194000	30.1	9.000	N	9.6	33.8	63.9
0.578000	22.1	9.000	N	9.6	33.9	56.0
1.242000	14.9	9.000	N	9.6	41.1	56.0
3.818000	25.2	9.000	N	9.7	30.8	56.0
4.306000	23.0	9.000	N	9.7	33.0	56.0
5.438000	17.4	9.000	N	9.8	42.6	60.0

Limit and Margin AV

Frequency (MHz)	Average (dBuV)	Bandwidth (kHz)	Line	Corr. (dB)	Margin (dB)	Limit (dBuV)
0.194000	20.9	9.000	N	9.6	33.0	53.9
0.578000	20.6	9.000	N	9.6	25.4	46.0
1.242000	12.0	9.000	N	9.6	34.0	46.0
3.818000	16.9	9.000	N	9.7	29.1	46.0
4.306000	15.5	9.000	N	9.7	30.5	46.0
5.438000	14.2	9.000	N	9.8	35.8	50.0

Remark:

1. Corr. Factor (dB) = LISN Factor (dB) + Cable Loss (dB)
2. Margin (dB) = Limit (dBuV) – Level (dBuV)

8. Frequency Stability Test

8.1 Test setup & procedure

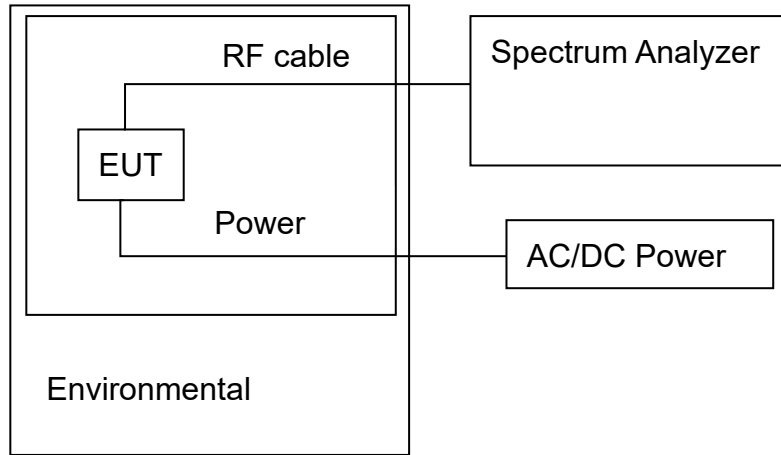

Note1: The frequency stability is measured with the temperature variation range of -20°C to +50°C, and voltage supply variation range of 85% to 115% of nominal AC supply voltage.

Note2: To ensure emission at the band-edge is maintained within the authorized band, the frequency 802.11a/n-HT20 channel 149, 157, 165 are selected to test and the worst case was reported.

Block Diagram:

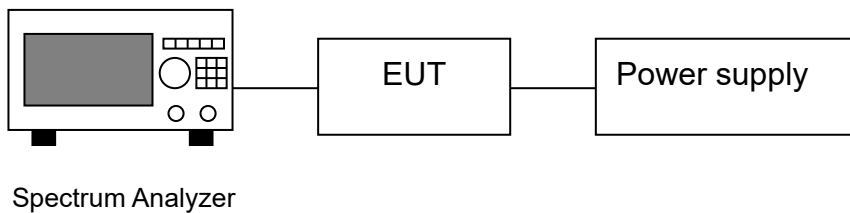

8.2 Frequency Stability Test Data

20C is taken as temperature in normal condition (NT).

120.0 VAC is normal voltage (NV)

102.0 VAC is low voltage (LV)

138 VAC is high voltage (HV)

The more detail please refer to "Appendix of 221125030SZN-004" Appendix F.

Note: All emissions are maintained within the band of operation under all conditions of normal operation as specified in the user manual. It fulfills the requirement of 15.407(g).

Appendix A: Test equipment list

Equipment No.	Equipment	Manufacturer	Model No.	Serial No.	Cal. Date	Due Date
SZ182-02	RF Power Meter	Anritsu	ML2496A	1302005	2024-04-22	2025-04-22
SZ182-02-01	Power Sensor	Anritsu	MA2411B	1207429	2024-04-22	2025-04-22
SZ061-13	BiConiLog Antenna	ETS	3142E	00217919	2022-07-13	2025-07-13
SZ185-03	EMI Receiver	R&S	ESCI	101975	2024-04-23	2025-04-23
SZ061-09	Double - Ridged Waveguide Horn Antenna	ETS	3115	00092346	2022-10-14	2025-10-14
SZ056-06	Signal Analyzer	R&S	FSV 40	101101	2023-12-13	2024-12-13
SZ181-08	Microwave System Amplifier	keysight	83017A	MY57280108	2024-07-29	2025-07-29
SZ188-05	Anechoic Chamber	ETS	FACT 3-2.0	CT001880-Q13914102	2021-12-12	2024-12-12
SZ062-02	RF Cable	RADIALL	RG 213U	--	2024-05-01	2024-11-01
SZ062-05	RF Cable	RADIALL	0.04-26.5GHz	--	2024-05-01	2024-11-01
SZ062-12	RF Cable	RADIALL	0.04-26.5GHz	--	2024-05-01	2024-11-01
SZ185-02	EMI Test Receiver	R&S	ESCI	100692	2024-07-09	2025-07-09
SZ187-02	Two-Line V-Network	R&S	ENV216	100073	2024-04-23	2025-04-23
SZ188-03	Shielding Room	ETS	RFD-100	4100	2022-12-20	2025-12-20
SZ062-16	RF Cable	HUBER+SUHNER	CBL2-BN-1m	110127-2231000	2024-07-10	2025-07-10
SZ016-12	Programmable Temperature & Humidity Chamber	Terchy	MHK-120NK	AB0105	2023-12-14	2024-12-14

Expanded uncertainty of radiated emission measurement is ± 4.9 dB.

Expanded uncertainty of conducted emission measurement is ± 3.6 dB.

***** End of Report*****