

**CFR 47 FCC PART 22 H
CFR 47 FCC PART 24 E
CFR 47 FCC PART 27**

TEST REPORT

For

LTE MODULE

MODEL NUMBER: EG25-G

REPORT NUMBER: 4791318657-1-RF-5

ISSUE DATE: March 20, 2024

FCC ID: 2A46G-EG25-G

Prepared for

**Guangzhou Xaircraft Technology CO.,LTD
Block C, No.115, Gaopu Road, Tianhe District, GuangzhouCity, Guangdong, P.R.
510663 China**

Prepared by

UL Verification Services (Guangzhou) Co., Ltd, Song Shan Lake Branch

Building 10, Innovation Technology Park, No. 1, Li Bin Road, Song Shan Lake Hi-Tech Development Zone Dongguan, 523808, People's Republic of China

Tel: +86 769 22038881

Fax: +86 769 33244054

Website: www.ul.com

Revision History

<u>Rev.</u>	<u>Issue Date</u>	<u>Revisions</u>	<u>Revised By</u>
V0	03/20/2024	Initial Issue	

Note:

1. This test report is only published to and used by the applicant, and it is not for evidence purpose in China.
2. The measurement result for the sample received is <Pass> according to < CFR 47 FCC PART 22 H >< CFR 47 FCC PART 24 E> > < CFR 47 FCC PART 27 > < when < Simple Acceptance > decision rule is applied.
3. This test report includes radiated test results and conducted power test results due to the change of GSM/WCDMA/LTE antenna from the original model (FCC ID: 2A46G-EG25-G).

TABLE OF CONTENTS

1. ATTESTATION OF TEST RESULTS	4
2. TEST METHODOLOGY	5
3. FACILITIES AND ACCREDITATION	5
4. CALIBRATION AND UNCERTAINTY	6
4.1. <i>MEASURING INSTRUMENT CALIBRATION</i>	<i>6</i>
4.2. <i>MEASUREMENT UNCERTAINTY.....</i>	<i>6</i>
5. EQUIPMENT UNDER TEST	7
5.1. <i>DESCRIPTION OF EUT</i>	<i>7</i>
5.2. <i>TEST CHANNEL CONFIGURATION.....</i>	<i>7</i>
5.3. <i>MAXIMUM AVERAGE OUTPUT POWER</i>	<i>8</i>
5.4. <i>WORST-CASE CONFIGURATION AND MODE.....</i>	<i>9</i>
5.5. <i>DESCRIPTION OF AVAILABLE ANTENNAS</i>	<i>10</i>
5.6. <i>DESCRIPTION OF TEST SETUP.....</i>	<i>11</i>
6. MEASURING INSTRUMENT AND SOFTWARE USED	12
7. ANTENNA TERMINAL TEST RESULTS.....	13
7.1. <i>EFFECTIVE (ISOTROPIC) RADIATED POWER OF TRANSMITTER</i>	<i>13</i>
8. RADIATED SPURIOUS EMISSIONS	17

1. ATTESTATION OF TEST RESULTS

Applicant Information

Company Name: Guangzhou Xaircraft Technology CO.,LTD
Address: Block C, No.115, Gaopu Road, Tianhe District, GuangzhouCity, Guangdong, P.R. 510663 China

Manufacturer Information

Company Name: Guangzhou Xaircraft Technology CO.,LTD
Address: Block C, No.115, Gaopu Road, Tianhe District, GuangzhouCity, Guangdong, P.R. 510663 China

EUT Information

EUT Name: LTE MODULE
Model: EG25-G
Sample Received Date: February 28, 2024
Sample Status: Normal
Sample ID: 7208081
Date of Tested: February 28, 2024 to March 19, 2024

APPLICABLE STANDARDS	
STANDARD	TEST RESULTS
CFR 47 FCC PART 22 H	PASS
CFR 47 FCC PART 24 E	PASS
CFR 47 FCC PART 27	PASS

Prepared By:

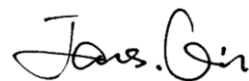

James Qin
Project Engineer

Checked By:

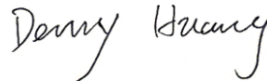

Denny Huang
Senior Project Engineer

Approved By:



Stephen Guo
Operations Manager

2. TEST METHODOLOGY

The tests documented in this report were performed in accordance with ANSI C63.26-2015, 971168 D01 Power Meas License Digital Systems v03r01, 971168 D02 Misc Rev Approv License Devices v02r01, 412172 D01 v01r01 Determining ERP and EIRP, CFR 47 FCC Part 2, Part 22 H, Part 24 E, Part 27.

3. FACILITIES AND ACCREDITATION

Accreditation Certificate	<p>A2LA (Certificate No.: 4102.01) UL Verification Services (Guangzhou) Co., Ltd. Song Shan Lake Branch. has been assessed and proved to be in compliance with A2LA.</p> <p>FCC (FCC Designation No.: CN1187) UL Verification Services (Guangzhou) Co., Ltd. Song Shan Lake Branch. Has been recognized to perform compliance testing on equipment subject to the Commission's Declaration of Conformity (DoC) and Certification rules</p> <p>ISED (Company No.: 21320) UL Verification Services (Guangzhou) Co., Ltd. Song Shan Lake Branch. has been registered and fully described in a report filed with ISED. The Company Number is 21320 and the test lab Conformity Assessment Body Identifier (CABID) is CN0046.</p> <p>VCCI (Registration No.: G-20192, C-20153, T-20155 and R-20202) UL Verification Services (Guangzhou) Co., Ltd. Song Shan Lake Branch. has been assessed and proved to be in compliance with VCCI, the Membership No. is 3793. Facility Name: Chamber D, the VCCI registration No. is G-20192 and R-20202 Shielding Room B, the VCCI registration No. is C-20153 and T-20155</p>
---------------------------	--

Note 1: All tests measurement facilities use to collect the measurement data are located at Building 10, Innovation Technology Park, Song Shan Lake Hi tech Development Zone, Dongguan, 523808, China

Note 2: The test anechoic chamber in UL Verification Services (Guangzhou) Co., Ltd. Song Shan Lake Branch had been calibrated and compared to the open field sites and the test anechoic chamber is shown to be equivalent to or worst case from the open field site.

Note 3: For below 30 MHz, lab had performed measurements at test anechoic chamber and comparing to measurements obtained on an open field site. And these measurements below 30 MHz had been correlated to measurements performed on an OFS.

4. CALIBRATION AND UNCERTAINTY

4.1. MEASURING INSTRUMENT CALIBRATION

The measuring equipment utilized to perform the tests documented in this report has been calibrated in accordance with the manufacturer's recommendations and is traceable to recognize national standards.

4.2. MEASUREMENT UNCERTAINTY

Where relevant, the following measurement uncertainty levels have been estimated for tests performed on the apparatus:

Test Item	Uncertainty
Conduction emission	3.62 dB
Radiated Emission (Included Fundamental Emission) (9 kHz ~ 30 MHz)	2.2 dB
Radiated Emission (Included Fundamental Emission) (30 MHz ~ 1 GHz)	4.00 dB
Radiated Emission (Included Fundamental Emission) (1 GHz to 40 GHz)	5.78 dB (1 GHz-18 GHz)
	5.23dB (18 GHz-26 GHz)
	5.64 dB (26 GHz-40 GHz)
Bandwidth	1.1 %
Note: This uncertainty represents an expanded uncertainty expressed at approximately the 95 % confidence level using a coverage factor of k=2.	

5. EQUIPMENT UNDER TEST

5.1. DESCRIPTION OF EUT

EUT Name	LTE MODULE
Model	EG25-G

5.2. TEST CHANNEL CONFIGURATION

Band	Mode	Low	Middle	High
GSM850	GRPS/EGPRS	128	190	251
		824.2 MHz	836.6 MHz	848.8 MHz
GSM1900	GRPS/EGPRS	512	661	810
		1850.2 MHz	1880.0 MHz	1909.8 MHz
WCDMA Band 2	HSDPA/HSUPA	9262	9400	9538
		1852.4 MHz	1880.0 MHz	1907.6 MHz
WCDMA Band 4	HSDPA/HSUPA	1312	1413	1513
		1712.4 MHz	1732.6 MHz	1752.6 MHz

5.3. MAXIMUM AVERAGE OUTPUT POWER

GSM 850						
Part 22H						
ERP Limit(W)	7					
Antenna Gain (dBi)	1.78					
Mode	Ch	Freq(MHz)	Conducted Average	ERP	99% OBW	Emission
			power (dBm)	(W)	(MHz)	Designator
GRPS(GMSK)	190	836.6	31.55	1.31	0.245	245KGXW
EGPRS(8PSK)	251	848.8	25.72	0.34	0.245	245KG7W

GSM 1900						
Part 24						
EIRP Limit(W)	2					
Antenna Gain (dBi)	2.14					
Mode	Ch	Freq(MHz)	Conducted Average	EIRP	99% OBW	Emission
			power (dBm)	(W)	(MHz)	Designator
GRPS(GMSK)	512	1850.2	29.45	1.44	0.243	243KGXW
EGPRS(8PSK)	512	1850.2	25.96	0.65	0.246	246KG7W

WCDMA Band2						
Part 24						
EIRP Limit(W)	2					
Antenna Gain (dBi)	2.14					
Mode	Ch	Freq(MHz)	Conducted Average	EIRP	99% OBW	Emission
			power (dBm)	(W)	(MHz)	Designator
Rel99	9400	1907.6	21.80	0.25	4.137	4M14F9W
HSDPA	9400	1907.6	21.01	0.21	4.144	4M14F9W
HSUPA	9400	1907.6	20.63	0.19	4.132	4M13F9W

WCDMA Band4						
Part 27						
EIRP Limit(W)	1					
Antenna Gain (dBi)	2.44					
Mode	Ch	Freq(MHz)	Conducted Average	EIRP	99% OBW	Emission
			power (dBm)	(W)	(MHz)	Designator
Rel99	1513	1752.6	22.74	0.33	4.131	4M13F9W
HSDPA	1513	1752.6	21.79	0.26	4.140	4M14F9W
HSUPA	1513	1752.6	21.52	0.25	4.130	4M13F9W

Note: Bold font is the Max. power for each band.

5.4. WORST-CASE CONFIGURATION AND MODE

The radiated spurious emissions measurements were carried out in semi-anechoic chamber with 3-meter test range, and EUT was investigated in three orthogonal orientations X, Y and Z. It was determined that X orientation was the worst-case orientation.

Radiated spurious emissions were investigated below 30 MHz, 30 MHz - 1 GHz and above 1 GHz. There were no emissions found on below 1GHz and above 18 GHz, the emissions between 1 GHz – 18 GHz were tested the highest transmitting power channel and the worse configuration.

For GSM850/1900, GPRS worst results are shown in test report. For WCDMA, HSDPA worst results are shown in test report.

The EUT have three kinds of antenna and have the same antenna type, only the worst-case antenna data record in this report.

5.5. DESCRIPTION OF AVAILABLE ANTENNAS

Antenna	Model	Antenna Type	Remark
Main	AN0827-FPC71GX	FPC	MAIN Antenna
Div.	AN0827-FPC72GX	FPC	DIV Antenna
Antenna	Band	Antenna Type	MAX Antenna Gain (dBi)
Main	GSM850	FPC	1.78
Main	GSM1900	FPC	2.14
Main	WCDMA Band 2	FPC	2.14
Main	WCDMA Band 4	FPC	2.44

Note: The value of the antenna gain was declared by customer.

Band	Transmit and Receive Mode	Description
GSM850	<input checked="" type="checkbox"/> 1TX, 2RX	Main antenna can be used as transmitting/receiving antenna, Div. antenna can be used as receiving antenna.
GSM1900	<input checked="" type="checkbox"/> 1TX, 2RX	Main antenna can be used as transmitting/receiving antenna, Div. antenna can be used as receiving antenna.
WCDMA Band 2	<input checked="" type="checkbox"/> 1TX, 2RX	Main antenna can be used as transmitting/receiving antenna, Div. antenna can be used as receiving antenna.
WCDMA Band 4	<input checked="" type="checkbox"/> 1TX, 2RX	Main antenna can be used as transmitting/receiving antenna, Div. antenna can be used as receiving antenna.

5.6. DESCRIPTION OF TEST SETUP

Conducted

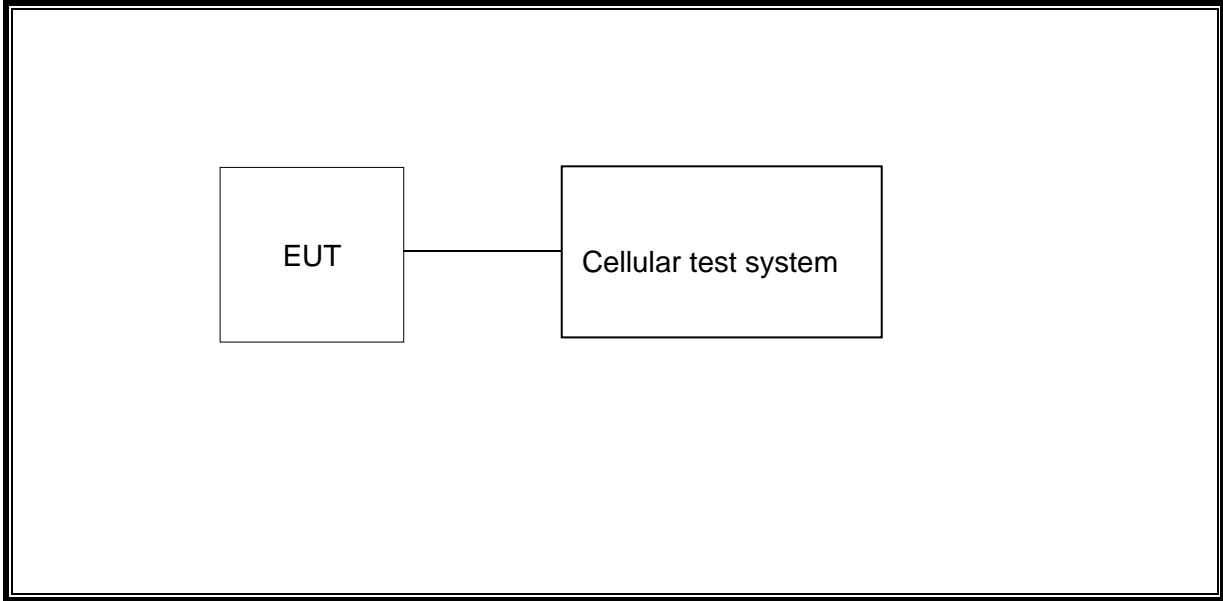

Radiated

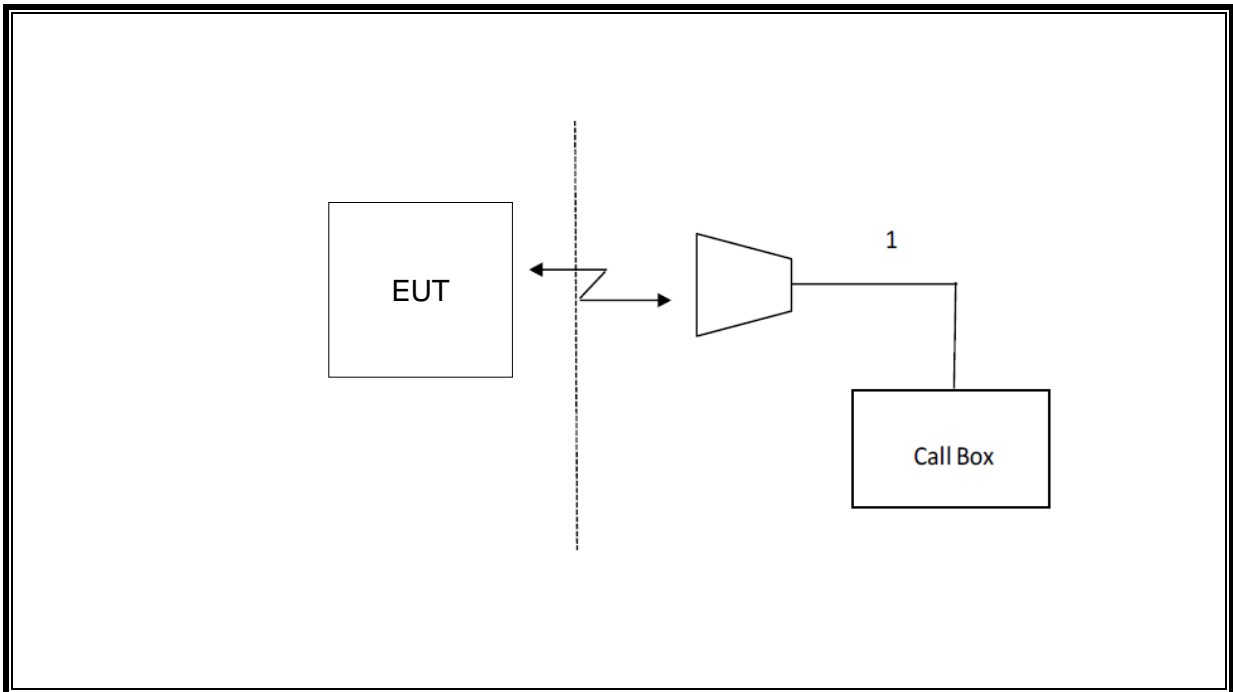

6. MEASURING INSTRUMENT AND SOFTWARE USED

Antenna Terminal Test						
Instrument						
Used	Equipment	Manufacturer	Model No.	Serial No.	Last Cal.	Next Cal.
<input checked="" type="checkbox"/>	Spectrum Analyzer	R&S	FSV40	S422060001	Oct.12, 2023	Oct.11, 2024
<input checked="" type="checkbox"/>	Wideband Radio Communication Tester	R&S	CMW500	155523	Oct.12, 2023	Oct.11, 2024
<input checked="" type="checkbox"/>	DC Power Supply	Array	3662A	A1512015	Oct.12, 2023	Oct.11, 2024
Software						
Used	Description	Manufacturer	Name	Version		
<input checked="" type="checkbox"/>	Tonsend Cellular Test System	Tonsend	JS1120 RF Auto Test System	3.1.46		
Radiated Test						
Instrument						
Used	Equipment	Manufacturer	Model No.	Serial No.	Last Cal.	Next Cal.
<input checked="" type="checkbox"/>	MXE EMI Receiver	KESIGHT	N9038A	MY56400036	Oct.12, 2023	Oct.11, 2024
<input checked="" type="checkbox"/>	Hybrid Log Periodic Antenna	TDK	HLP-3003C	130959	Aug.02, 2021	Aug.01, 2024
<input checked="" type="checkbox"/>	Preamplifier	HP	8447D	2944A09099	Oct.12, 2023	Oct.11, 2024
<input checked="" type="checkbox"/>	EMI Measurement Receiver	R&S	ESR26	101377	Oct.12, 2023	Oct.11, 2024
<input checked="" type="checkbox"/>	Horn Antenna	TDK	HRN-0118	130940	July 20, 2021	July 19, 2024
<input checked="" type="checkbox"/>	Horn Antenna	Schwarzbeck	BBHA9170	697	July 20, 2021	July 19, 2024
<input checked="" type="checkbox"/>	Preamplifier	TDK	PA-02-0118	TRS-305-00067	Oct.12, 2023	Oct.11, 2024
<input checked="" type="checkbox"/>	Preamplifier	TDK	PA-02-2	TRS-307-00003	Oct.12, 2023	Oct.11, 2024
<input checked="" type="checkbox"/>	Loop antenna	Schwarzbeck	1519B	00008	Dec.14, 2021	Dec.13, 2024
<input checked="" type="checkbox"/>	High Pass Filter	Wi	WHKX10-2700-3000-18000-40SS	23	Oct.12, 2023	Oct.11, 2024
Software						
Used	Description	Manufacturer	Name	Version		
<input checked="" type="checkbox"/>	Test Software for Radiated disturbance	Farad	EZ-EMC	Ver. UL-3A1		

7. ANTENNA TERMINAL TEST RESULTS

7.1. EFFECTIVE (ISOTROPIC) RADIATED POWER OF TRANSMITTER

RULE PART(S)

FCC: §2.1046, §22.913, §24.232, §27.50

LIMITS

22.913(a) The ERP of mobile transmitters and auxiliary test transmitters must not exceed 7 Watts.

24.232(c) Mobile/portable stations are limited to 2 watts e.i.r.p. peak power and the equipment must employ means to limit the power to the minimum necessary for successful communications.

27.50(c) Portable stations (hand-held devices) in the 600 MHz uplink band and the 698-746 MHz band, and fixed and mobile stations in the 600 MHz uplink band are limited to 3 watts ERP.

27.50(d) Fixed, mobile, and portable (hand-held) stations operating in the 1710-1755 MHz band and mobile and portable stations operating in the 1695-1710 MHz and 1755-1780 MHz bands are limited to 1 watts EIRP.

27.50(h) Mobile stations are limited to 2.0 watts EIRP. All user stations are limited to 2.0 watts transmitter output power.

In addition, when the transmitter power is measured in terms of average value, the peak-to-average ratio of the power shall not exceed 13 dB.

TEST PROCEDURE

Refer to ANSI C63.26:2015 and KDB 971168 D01 Section 5.6

$ERP/ EIRP = P_{Meas} + GT - LC$

where:

ERP or EIRP = effective or equivalent isotropically radiated power, respectively (expressed in the same units as P_{Meas} , typically dBW or dBm);

P_{Meas} = measured transmitter output power or PSD, in dBm or dBW;

GT = gain of the transmitting antenna, in dBd (ERP) or dBi (EIRP);

LC = signal attenuation in the connecting cable between the transmitter and antenna, in dB

The transmitter has a maximum radiated ERP / EIRP output powers as follows:

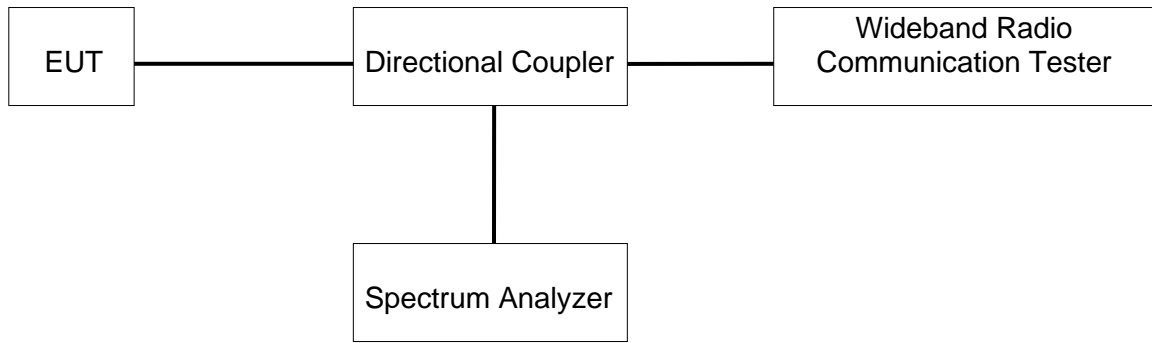
TEST SETUP**TEST ENVIRONMENT**

Temperature	23.1°C	Relative Humidity	63.8%
Atmosphere Pressure	101kPa	Test Voltage	DC 5.8 V

RESULTS

GSM 850

GSM 850			Conducted Power(dBm)		
Bandwidth	Band		Channel	Channel	Channel
			128	190	251
0.2M	GPRS850	TestSlot 1	31.38	31.55	31.37
		TestSlot 2	30.86	30.94	31
		TestSlot 3	29.22	29.47	29.41
		TestSlot 4	27.8	28.01	28.3
	EGPRS850	TestSlot 1	25.36	25.46	25.72
		TestSlot 2	24.14	24.25	24.53
		TestSlot 3	22.53	22.62	22.88
		TestSlot 4	21.33	21.4	21.76

GSM 1900

GSM 1900			Conducted Power(dBm)		
Bandwidth	Band		Channel	Channel	Channel
			512	661	810
0.2M	GPRS1900	TestSlot 1	29.45	29.39	29.11
		TestSlot 2	28.01	28.12	28.28
		TestSlot 3	26.19	26.31	26.43
		TestSlot 4	24.79	25.23	25.03
	EGPRS1900	TestSlot 1	25.96	25.94	25.78
		TestSlot 2	25.06	25.11	24.91
		TestSlot 3	23.55	23.64	23.56
		TestSlot 4	22.32	22.35	22.32

WCDMA

Band 2		Average Power (dBm)		
		9262CH	9400CH	9538CH
WCDMA	12.2kbps RMC	21.72	21.8	21.48
	64kbps RMC	21.59	21.61	21.32
	144kbps RMC	21.59	21.61	21.35
	384kbps RMC	21.62	21.66	21.31
HSDPA	Subtest 1	20.62	20.8	20.54
	Subtest 2	20.55	20.87	20.6
	Subtest 3	20.55	20.98	20.68
	Subtest 4	20.63	21.01	20.7
HSUPA	Subtest 1	19.84	20.59	19.85
	Subtest 2	19.94	20.57	19.83
	Subtest 3	20.02	20.56	20.05
	Subtest 4	19.99	20.61	19.84
	Subtest 5	20.75	20.63	20.58

Band 4		Average Power (dBm)		
		1312CH	1413CH	1513CH
WCDMA	12.2kbps RMC	22.66	22.59	22.74
	64kbps RMC	22.55	22.46	22.55
	144kbps RMC	22.5	22.39	22.64
	384kbps RMC	22.52	22.43	22.62
HSDPA	Subtest 1	21.69	21.64	21.79
	Subtest 2	21.76	21.65	21.70
	Subtest 3	21.76	21.65	21.83
	Subtest 4	21.76	21.64	21.82
HSUPA	Subtest 1	20.98	21.2	21.14
	Subtest 2	21.2	21.17	21.42
	Subtest 3	21.12	20.97	21.12
	Subtest 4	21.27	21.13	21.12
	Subtest 5	21.52	21.48	21.43

8. RADIATED SPURIOUS EMISSIONS

RULE PART(S)

FCC: §2.1053, §22.917, §24.238, §27.53.

LIMIT

Part §22.917(a), §24.238(a), §27.53(h)

The power of any emission outside of the authorized operating frequency ranges must be attenuated below the transmitting power (P) by a factor of at least $43 + 10 \log (P)$ dB.

TEST PROCEDURE

According to the C 63.26-2015 section 5.5.2.2.3

Below 1GHz test procedure as below:

For radiated emissions measurements performed at frequencies less than or equal to 1 GHz, the EUT shall be placed on a RF-transparent table or support at a nominal height of 80 cm above the reference ground plane. Radiated measurements shall be made with the measurement antenna positioned in both horizontal and vertical polarization. The measurement antenna shall be varied from 1 m to 4 m in height above the reference ground in a search for the relative positioning that produces the maximum radiated signal level (i.e., field strength or received power). When orienting the measurement antenna in vertical polarization, the minimum height of the lowest element of the antenna shall clear the site reference ground plane by at least 25 cm.

Above 1GHz test procedure as below:

For radiated measurements performed at frequencies above 1 GHz, the EUT shall be placed on an RF transparent table or support at a nominal height of 1.5 m above the ground plane. Radiated measurements shall be made with the measurement antenna positioned in both horizontal and vertical polarization. The height scan of the measurement antenna shall be varied from 1 m to 4 m in a search for the relative positioning that produces the maximum radiated signal level (i.e., field strength or received power). When using the direct field strength method and the EUT is manipulated through three different orientations, then the scan height range of the measurement antenna is limited to 2.5 m, or 0.5 m above the top of the EUT, whichever is higher.

Radiated Power Measurement Calculation According to ANSI C63.26-2015

- a) E (dB μ V/m) = Measured amplitude level (dB μ V) + Cable Loss (dB) + Antenna Factor (dB/m).
- b) E (dB μ V/m) = Measured amplitude level (dBm) + 107 + Cable Loss (dB) + Antenna Factor (dB/m).
- c) E (dB μ V/m) = EIRP (dBm) - 20log(D) + 104.8; where D is the measurement distance (in the far field region) in m.
- d) EIRP (dBm) = E (dB μ V/m) + 20log(D) - 104.8; where D is the measurement distance (in the far field region) in m.

So, from d)

The measuring distance is usually at 3m, then $20 * \text{Log}(3) = 9.5424$

Then, EIRP (dBm) = E (dB μ V/m) + 9.5424 - 104.8 = E (dB μ V/m) - 95.2576

The limit line is derived from $43 + 10\log(P)$ dB below the transmitter power P(Watts)

$$\begin{aligned} &= P(W) - [43 + 10\log(P)] \text{ (dB)} \\ &= [30 + 10\log(P)] \text{ (dBm)} - [43 + 10\log(P)] \text{ (dB)} \\ &= -13\text{dBm}. \end{aligned}$$

$$\text{EIRP}[\text{dBm}] = E[\text{dB}\mu\text{V/m}] - 95.25$$

$$E[\text{dB}\mu\text{V/m}] = 95.25 + \text{EIRP}[\text{dBm}]$$

$$E[\text{dB}\mu\text{V/m}] = 82.25$$

NOTE 1: Radiated spurious emissions were investigated below 30 MHz, 30 MHz – 1 GHz and above 1 GHz. There were no emissions found on below 30 MHz and 30 MHz – 1 GHz.

Although these tests were performed other than open area test site, adequate comparison measurements were confirmed against 30 m open area test site.

Therefore sufficient tests were made to demonstrate that the alternative site produces results that correlate with the one of tests made in an open field based on KDB 414788.

NOTE 2: Please refer to section 5.4 for bandwidth and RB setting about LTE bands.

NOTE 3: All the test modes have been tested, only the worst data record in the report.

Note 4: For all radiated test, EUT in each of three orthogonal axis emissions had been tested, but only the worst case (X axis) data recorded in the report.

X axis, Y axis, Z axis positions:

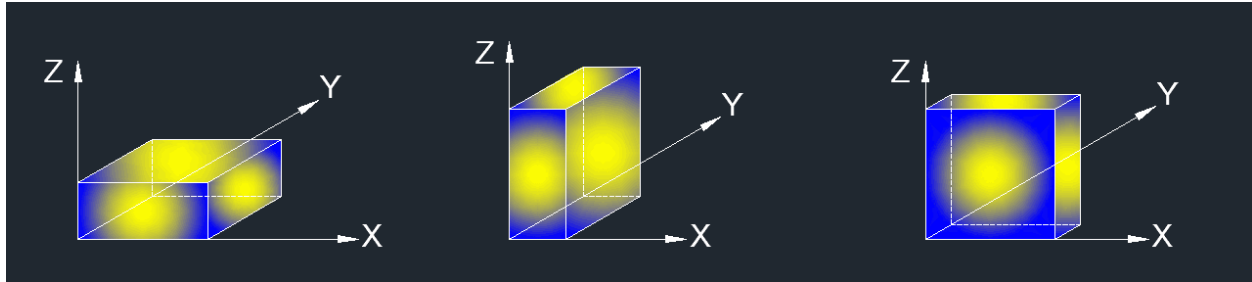

TEST SETUP

Test Setup for Below 1 GHz

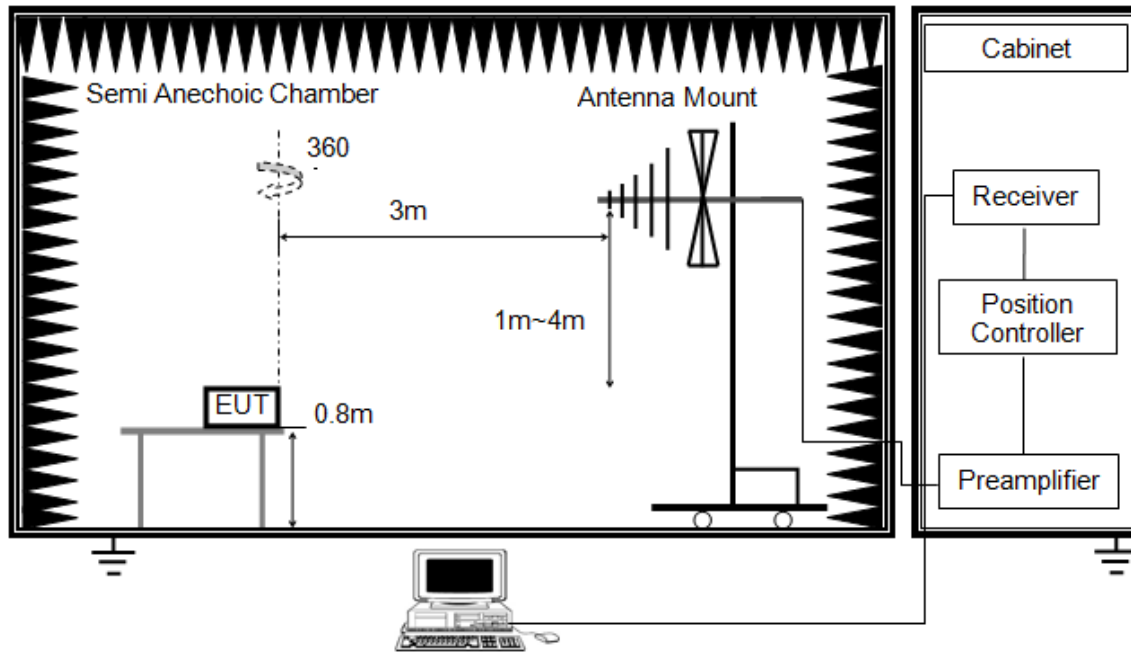

Test Setup for Above 1 GHz

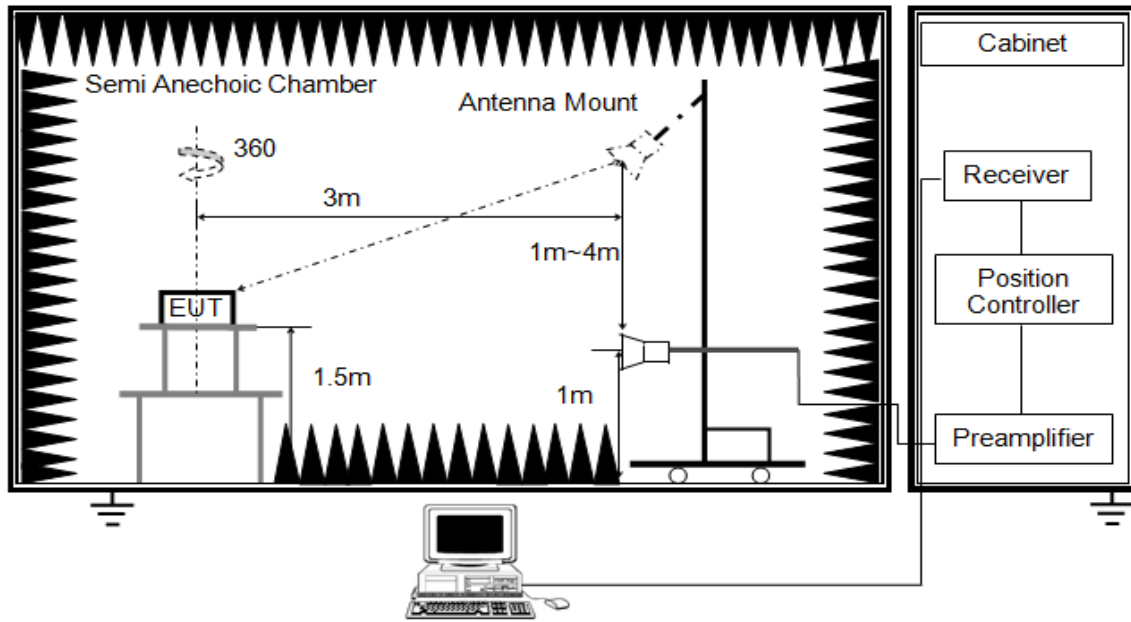

TEST ENVIRONMENT

Temperature	24.3°C	Relative Humidity	61%
Atmosphere Pressure	101kPa	Test Voltage	DC 5.8 V

RESULTS

GSM 850
GPRS- Low Channel-Horizontal (worst case)

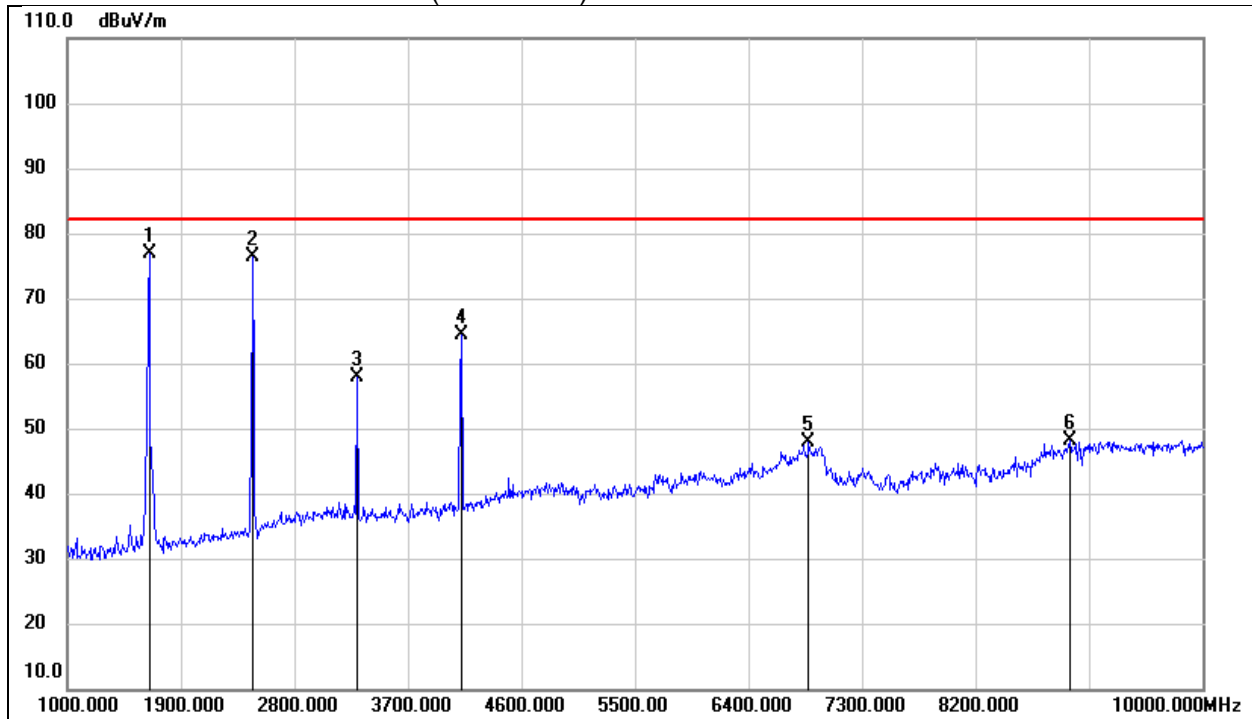

No.	Frequency (MHz)	Reading (dBuV)	Correct (dB/m)	Result (dBuV/m)	Limit (dBuV/m)	Margin (dB)	Remark
1	1648.000	88.99	-12.22	76.77	82.25	-5.48	peak
2	2467.000	84.92	-8.66	76.26	82.25	-5.99	peak
3	3295.000	63.74	-5.91	57.83	82.25	-24.42	peak
4	4123.000	68.36	-3.90	64.46	82.25	-17.79	peak
5	6877.000	42.21	5.60	47.81	82.25	-34.44	peak
6	8947.000	38.80	9.37	48.17	82.25	-34.08	peak

GPRS- Low Channel- Vertical

No.	Frequency (MHz)	Reading (dBuV)	Correct (dB/m)	Result (dBuV/m)	Limit (dBuV/m)	Margin (dB)	Remark
1	1648.000	88.94	-12.22	76.72	82.25	-5.53	peak
2	2467.000	82.46	-8.66	73.80	82.25	-8.45	peak
3	3295.000	66.01	-5.91	60.10	82.25	-22.15	peak
4	4114.000	51.49	-3.94	47.55	82.25	-34.70	peak
5	6976.000	38.53	6.09	44.62	82.25	-37.63	peak
6	9280.000	37.83	9.85	47.68	82.25	-34.57	peak

GPRS- Mid Channel- Horizontal

No.	Frequency (MHz)	Reading (dBuV)	Correct (dB/m)	Result (dBuV/m)	Limit (dBuV/m)	Margin (dB)	Remark
1	1666.000	84.31	-12.16	72.15	82.25	-10.10	peak
2	2512.000	83.55	-8.43	75.12	82.25	-7.13	peak
3	3340.000	64.65	-5.90	58.75	82.25	-23.50	peak
4	4186.000	51.55	-3.61	47.94	82.25	-34.31	peak
5	6886.000	39.89	5.63	45.52	82.25	-36.73	peak
6	9145.000	37.72	9.80	47.52	82.25	-34.73	peak

GPRS- Mid Channel- Vertical

No.	Frequency (MHz)	Reading (dBuV)	Correct (dB/m)	Result (dBuV/m)	Limit (dBuV/m)	Margin (dB)	Remark
1	1666.000	87.33	-12.16	75.17	82.25	-7.08	peak
2	2512.000	83.77	-8.43	75.34	82.25	-6.91	peak
3	3340.000	68.20	-5.90	62.30	82.25	-19.95	peak
4	4186.000	50.90	-3.61	47.29	82.25	-34.96	peak
5	6841.000	38.88	5.40	44.28	82.25	-37.97	peak
6	9181.000	37.48	9.81	47.29	82.25	-34.96	peak

GPRS- High Channel- Horizontal

No.	Frequency (MHz)	Reading (dBuV)	Correct (dB/m)	Result (dBuV/m)	Limit (dBuV/m)	Margin (dB)	Remark
1	1693.000	88.17	-12.08	76.09	82.25	-6.16	peak
2	2548.000	83.62	-8.25	75.37	82.25	-6.88	peak
3	3394.000	62.41	-5.88	56.53	82.25	-25.72	peak
4	4240.000	49.03	-3.35	45.68	82.25	-36.57	peak
5	6850.000	39.17	5.46	44.63	82.25	-37.62	peak
6	8794.000	38.48	8.29	46.77	82.25	-35.48	peak

GPRS- High Channel- Vertical

No.	Frequency (MHz)	Reading (dBuV)	Correct (dB/m)	Result (dBuV/m)	Limit (dBuV/m)	Margin (dB)	Remark
1	1693.000	87.67	-12.08	75.59	82.25	-6.66	peak
2	2548.000	79.62	-8.25	71.37	82.25	-10.88	peak
3	3394.000	63.41	-5.88	57.53	82.25	-24.72	peak
4	4240.000	51.03	-3.35	47.68	82.25	-34.57	peak
5	6850.000	38.67	5.46	44.13	82.25	-38.12	peak
6	9262.000	36.32	9.84	46.16	82.25	-36.09	peak

GSM 1900

GPRS- Low Channel- Horizontal

No.	Frequency (MHz)	Reading (dBuV)	Correct (dB/m)	Result (dBuV/m)	Limit (dBuV/m)	Margin (dB)	Remark
1	3690.000	61.66	-4.52	57.14	82.25	-25.11	peak
2	5550.000	52.01	0.98	52.99	82.25	-29.26	peak
3	9255.000	39.65	10.59	50.24	82.25	-32.01	peak
4	11100.000	43.82	15.14	58.96	82.25	-23.29	peak
5	13860.000	33.30	21.67	54.97	82.25	-27.28	peak
6	18000.000	28.95	25.69	54.64	82.25	-27.61	peak

GPRS- Low Channel- Vertical(worst case)

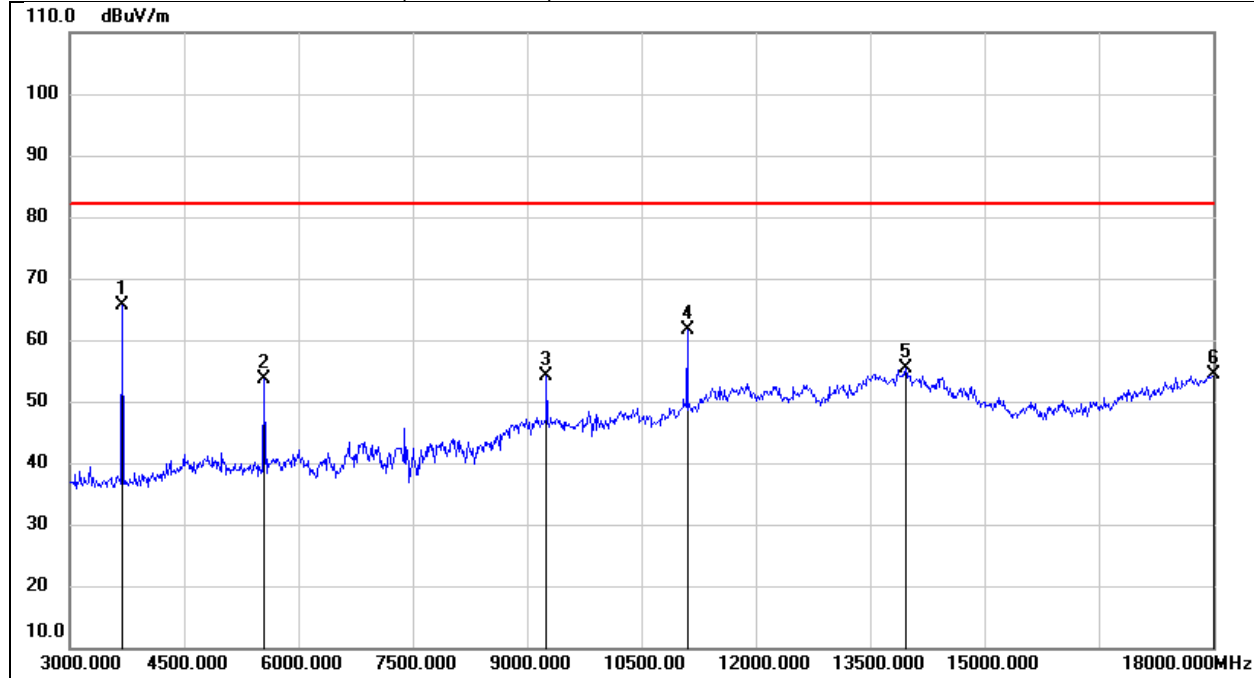

No.	Frequency (MHz)	Reading (dBuV)	Correct (dB/m)	Result (dBuV/m)	Limit (dBuV/m)	Margin (dB)	Remark
1	3690.000	70.21	-4.52	65.69	82.25	-16.56	peak
2	5550.000	52.74	0.98	53.72	82.25	-28.53	peak
3	9255.000	43.60	10.59	54.19	82.25	-28.06	peak
4	11100.000	46.44	15.14	61.58	82.25	-20.67	peak
5	13965.000	33.43	21.89	55.32	82.25	-26.93	peak
6	18000.000	28.80	25.69	54.49	82.25	-27.76	peak

GPRS- Mid Channel- Horizontal

No.	Frequency (MHz)	Reading (dBuV)	Correct (dB/m)	Result (dBuV/m)	Limit (dBuV/m)	Margin (dB)	Remark
1	3750.000	51.31	-4.38	46.93	82.25	-35.32	peak
2	5640.000	57.52	1.24	58.76	82.25	-23.49	peak
3	7515.000	42.90	6.33	49.23	82.25	-33.02	peak
4	9405.000	38.64	10.66	49.30	82.25	-32.95	peak
5	11280.000	44.62	15.80	60.42	82.25	-21.83	peak
6	13935.000	32.95	21.82	54.77	82.25	-27.48	peak

GPRS- Mid Channel- Vertical

No.	Frequency (MHz)	Reading (dBuV)	Correct (dB/m)	Result (dBuV/m)	Limit (dBuV/m)	Margin (dB)	Remark
1	3750.000	64.97	-4.38	60.59	82.25	-21.66	peak
2	5640.000	55.90	1.24	57.14	82.25	-25.11	peak
3	7515.000	48.34	6.33	54.67	82.25	-27.58	peak
4	9405.000	43.11	10.66	53.77	82.25	-28.48	peak
5	11280.000	43.63	15.80	59.43	82.25	-22.82	peak
6	13170.000	36.68	19.46	56.14	82.25	-26.11	peak

GPRS- High Channel- Horizontal

No.	Frequency (MHz)	Reading (dBuV)	Correct (dB/m)	Result (dBuV/m)	Limit (dBuV/m)	Margin (dB)	Remark
1	3810.000	53.92	-4.24	49.68	82.25	-32.57	peak
2	5730.000	52.88	1.49	54.37	82.25	-27.88	peak
3	8910.000	38.35	9.82	48.17	82.25	-34.08	peak
4	11460.000	39.57	16.46	56.03	82.25	-26.22	peak
5	13605.000	34.37	21.12	55.49	82.25	-26.76	peak
6	17865.000	30.54	24.89	55.43	82.25	-26.82	peak

GPRS- High Channel- Vertical

No.	Frequency (MHz)	Reading (dBuV)	Correct (dB/m)	Result (dBuV/m)	Limit (dBuV/m)	Margin (dB)	Remark
1	3810.000	63.39	-4.24	59.15	82.25	-23.10	peak
2	5730.000	48.17	1.49	49.66	82.25	-32.59	peak
3	7635.000	43.89	6.33	50.22	82.25	-32.03	peak
4	9555.000	42.14	10.85	52.99	82.25	-29.26	peak
5	11460.000	39.80	16.46	56.26	82.25	-25.99	peak
6	13365.000	38.28	20.31	58.59	82.25	-23.66	peak

WCDMA Band 2

HSDPA- Low Channel- Horizontal

No.	Frequency (MHz)	Reading (dBuV)	Correct (dB/m)	Result (dBuV/m)	Limit (dBuV/m)	Margin (dB)	Remark
1	3705.000	48.07	-4.48	43.59	82.25	-38.66	peak
2	5550.000	45.84	0.98	46.82	82.25	-35.43	peak
3	11835.000	34.94	17.51	52.45	82.25	-29.80	peak
4	13500.000	34.05	20.90	54.95	82.25	-27.30	peak
5	13980.000	33.40	21.92	55.32	82.25	-26.93	peak
6	17700.000	31.26	23.91	55.17	82.25	-27.08	peak

HSDPA- Low Channel- Vertical

No.	Frequency (MHz)	Reading (dBuV)	Correct (dB/m)	Result (dBuV/m)	Limit (dBuV/m)	Margin (dB)	Remark
1	3690.000	57.73	-4.52	53.21	82.25	-29.04	peak
2	5550.000	44.72	0.98	45.70	82.25	-36.55	peak
3	11775.000	34.86	17.35	52.21	82.25	-30.04	peak
4	12675.000	36.39	17.99	54.38	82.25	-27.87	peak
5	13920.000	33.60	21.79	55.39	82.25	-26.86	peak
6	18000.000	29.42	25.69	55.11	82.25	-27.14	peak

HSDPA- Mid Channel- Horizontal

No.	Frequency (MHz)	Reading (dBuV)	Correct (dB/m)	Result (dBuV/m)	Limit (dBuV/m)	Margin (dB)	Remark
1	3750.000	49.64	-4.38	45.26	82.25	-36.99	peak
2	5640.000	43.79	1.24	45.03	82.25	-37.22	peak
3	11655.000	35.76	17.01	52.77	82.25	-29.48	peak
4	12240.000	35.10	17.79	52.89	82.25	-29.36	peak
5	13920.000	33.76	21.79	55.55	82.25	-26.70	peak
6	17955.000	29.71	25.42	55.13	82.25	-27.12	peak

HSDPA- Mid Channel- Vertical(worst case)

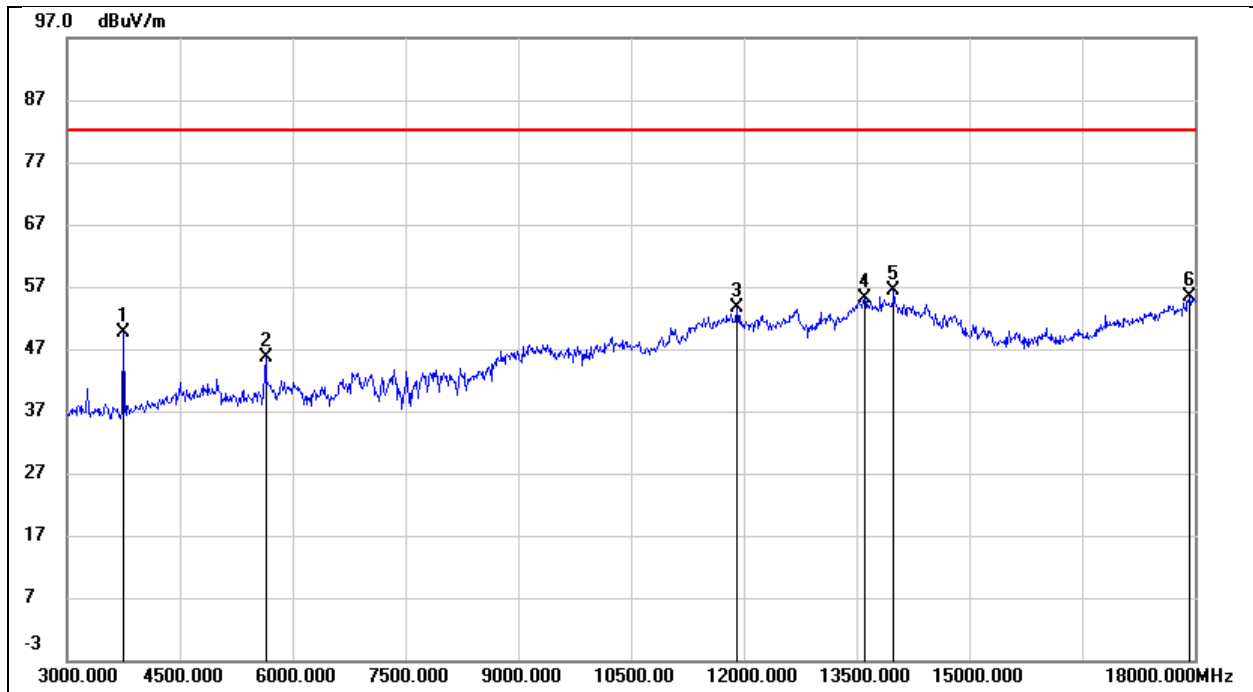

No.	Frequency (MHz)	Reading (dBuV)	Correct (dB/m)	Result (dBuV/m)	Limit (dBuV/m)	Margin (dB)	Remark
1	3750.000	54.07	-4.38	49.69	82.25	-32.56	peak
2	5640.000	44.49	1.24	45.73	82.25	-36.52	peak
3	11910.000	35.86	17.72	53.58	82.25	-28.67	peak
4	13605.000	34.00	21.12	55.12	82.25	-27.13	peak
5	13995.000	34.54	21.95	56.49	82.25	-25.76	peak
6	17925.000	30.14	25.25	55.39	82.25	-26.86	peak

HSDPA- High Channel- Horizontal

No.	Frequency (MHz)	Reading (dBuV)	Correct (dB/m)	Result (dBuV/m)	Limit (dBuV/m)	Margin (dB)	Remark
1	4770.000	41.73	-0.43	41.30	82.25	-40.95	peak
2	6870.000	36.86	6.05	42.91	82.25	-39.34	peak
3	9135.000	36.89	10.55	47.44	82.25	-34.81	peak
4	11670.000	35.37	17.07	52.44	82.25	-29.81	peak
5	13635.000	33.92	21.19	55.11	82.25	-27.14	peak
6	18000.000	29.06	25.69	54.75	82.25	-27.50	peak

HSDPA- High Channel- Vertical

No.	Frequency (MHz)	Reading (dBuV)	Correct (dB/m)	Result (dBuV/m)	Limit (dBuV/m)	Margin (dB)	Remark
1	3810.000	48.08	-4.24	43.84	82.25	-38.41	peak
2	7035.000	36.50	6.67	43.17	82.25	-39.08	peak
3	9750.000	36.20	11.35	47.55	82.25	-34.70	peak
4	11910.000	34.80	17.72	52.52	82.25	-29.73	peak
5	13875.000	33.54	21.70	55.24	82.25	-27.01	peak
6	18000.000	29.62	25.69	55.31	82.25	-26.94	peak

WCDMA Band 4

HSDPA- Low Channel- Horizontal(worst case)

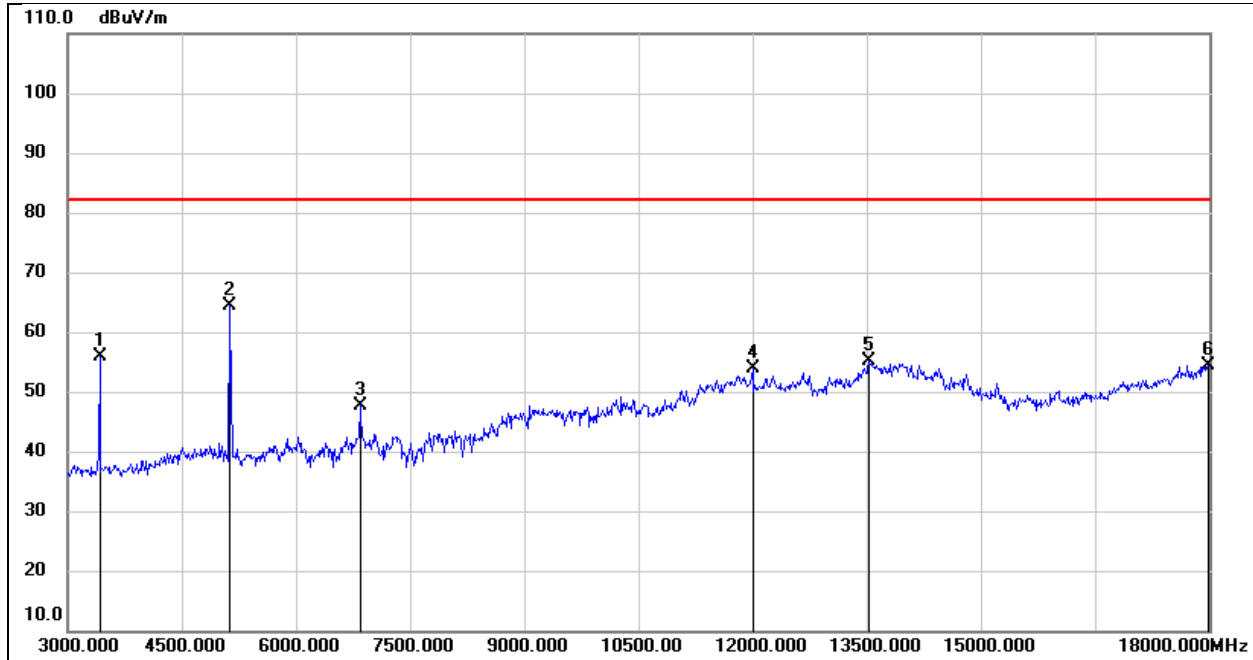

No.	Frequency (MHz)	Reading (dBuV)	Correct (dB/m)	Result (dBuV/m)	Limit (dBuV/m)	Margin (dB)	Remark
1	3420.000	60.87	-5.01	55.86	82.25	-26.39	peak
2	5130.000	63.90	0.55	64.45	82.25	-17.80	peak
3	6840.000	41.72	5.89	47.61	82.25	-34.64	peak
4	12000.000	36.01	17.96	53.97	82.25	-28.28	peak
5	13530.000	34.19	20.96	55.15	82.25	-27.10	peak
6	17985.000	28.76	25.60	54.36	82.25	-27.89	peak

HSDPA- Low Channel- Vertical

No.	Frequency (MHz)	Reading (dBuV)	Correct (dB/m)	Result (dBuV/m)	Limit (dBuV/m)	Margin (dB)	Remark
1	3420.000	65.36	-5.01	60.35	82.25	-21.90	peak
2	5130.000	63.74	0.55	64.29	82.25	-17.96	peak
3	10275.000	40.56	12.54	53.10	82.25	-29.15	peak
4	12000.000	37.52	17.96	55.48	82.25	-26.77	peak
5	13620.000	34.16	21.15	55.31	82.25	-26.94	peak
6	17985.000	29.40	25.60	55.00	82.25	-27.25	peak

HSDPA- Mid Channel- Horizontal

No.	Frequency (MHz)	Reading (dBuV)	Correct (dB/m)	Result (dBuV/m)	Limit (dBuV/m)	Margin (dB)	Remark
1	3450.000	56.75	-4.99	51.76	82.25	-30.49	peak
2	5190.000	60.39	0.60	60.99	82.25	-21.26	peak
3	10395.000	37.10	12.78	49.88	82.25	-32.37	peak
4	12120.000	36.29	17.87	54.16	82.25	-28.09	peak
5	13650.000	33.96	21.21	55.17	82.25	-27.08	peak
6	18000.000	28.94	25.69	54.63	82.25	-27.62	peak

HSDPA- Mid Channel- Vertical

No.	Frequency (MHz)	Reading (dBuV)	Correct (dB/m)	Result (dBuV/m)	Limit (dBuV/m)	Margin (dB)	Remark
1	3465.000	62.93	-4.98	57.95	82.25	-24.30	peak
2	5190.000	60.53	0.60	61.13	82.25	-21.12	peak
3	8670.000	41.18	8.08	49.26	82.25	-32.99	peak
4	10395.000	39.45	12.78	52.23	82.25	-30.02	peak
5	12120.000	38.22	17.87	56.09	82.25	-26.16	peak
6	13860.000	34.22	21.67	55.89	82.25	-26.36	peak

HSDPA- High Channel- Horizontal

No.	Frequency (MHz)	Reading (dBuV)	Correct (dB/m)	Result (dBuV/m)	Limit (dBuV/m)	Margin (dB)	Remark
1	3495.000	57.74	-4.96	52.78	82.25	-29.47	peak
2	5250.000	54.36	0.64	55.00	82.25	-27.25	peak
3	7005.000	39.89	6.69	46.58	82.25	-35.67	peak
4	12270.000	35.35	17.77	53.12	82.25	-29.13	peak
5	13860.000	33.24	21.67	54.91	82.25	-27.34	peak
6	17925.000	30.01	25.25	55.26	82.25	-26.99	peak

HSDPA- High Channel- Vertical

No.	Frequency (MHz)	Reading (dBuV)	Correct (dB/m)	Result (dBuV/m)	Limit (dBuV/m)	Margin (dB)	Remark
1	3495.000	64.08	-4.96	59.12	82.25	-23.13	peak
2	5250.000	54.56	0.64	55.20	82.25	-27.05	peak
3	7005.000	41.93	6.69	48.62	82.25	-33.63	peak
4	12270.000	35.69	17.77	53.46	82.25	-28.79	peak
5	13920.000	33.08	21.79	54.87	82.25	-27.38	peak
6	17865.000	29.30	24.89	54.19	82.25	-28.06	peak

END OF REPORT