

# P40 Agricultural UAS

## User Manual

Version 1.0 EN

**XAG**

## **To User**

Dear user, thank you for choosing XAG products.

For safety purposes and better user experience, it is highly recommended that you read this manual carefully and strictly follow the instructions hereof.

## **Contact Us**

If you have any questions about this document, please contact our Technical Support team via email:  
[info@xa.com](mailto:info@xa.com)

## Safety Guidelines

- Please make sure that the drone operator has passed the drone operation training programme and obtained a drone pilot certificate prescribed by laws and regulations where the product is used in advance. Never operate the drone without permission unless otherwise provided.
- Observe the surroundings, ensure a safe distance from the obstacles and the crowd as well as eliminate unsafe conditions including environmental factors like bad weather and extreme temperatures before operation.
- NEVER operate while drowsy, drunk or in a poor mental state so as to prevent accidents.
- Keep the product away from heat to avoid damage to the electronic device and other components.
- Instead of operating alone, the beginner should seek help from a veteran beforehand and operate the drone accompanied by the veteran.
- Please operate within maximum takeoff weight to avoid dangers caused by overload.
- It is a MUST to do the pre-flight inspection and eliminate co-frequency interference prior to operation.
- Stay away from the operating machine. Do NOT touch the spinning propellers with your body or other components. Loose clothing is NEVER allowed as it should get caught in the spinning propellers easily and cause injury.
- For safety purposes, it is NOT recommended to install the propellers until finishing the trial run of the drone and inspections of the remote control devices, motors and other modules.
- NEVER install/remove any module or insert/extract circuit while the power is on.
- NEVER take the human body or animal, whether still or moving, as an obstacle for the obstacle avoidance experiment.
- NEVER impede, intervene or impact the drone with the human body, animal or any other object.
- Should there be adverse weather conditions like a strong wind, rain, snow and hail, hover the drone and return to home as soon as possible. Weather not permitting, hover the drone and fly towards a nearby safe place.
- Drone operator shall strictly comply with relevant laws and regulations where the product is used, including but not limited to the flight height, flight area and visual line of sight.

## List of Items

Please check that the following items are all present when unpacking the box. Should there be any item missed, please contact your dealer.

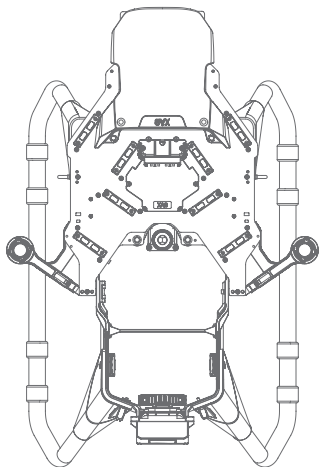

Airframe  
×1



No.4 Arm  
Module  
×1



No.3 Arm  
Module  
×1



No.2 Arm  
Module  
×1



No.1 Arm  
Module  
×1

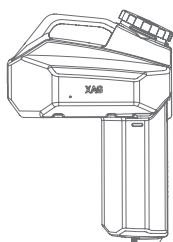

Smart Liquid Tank (20L)  
×2

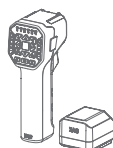

ACS2(B) ControlStick<sup>[1]</sup>(X4 RTK Ver)  
×1



RealTerra (optional)  
×1



Tool Kit  
×1



USB-Type-C Cable  
×1

[1]: ACS2(B) ControlStick namely ACS2 Remote Control.

# About P40 Agricultural UAV

The main components of P40 Agricultural UAV are as follows:

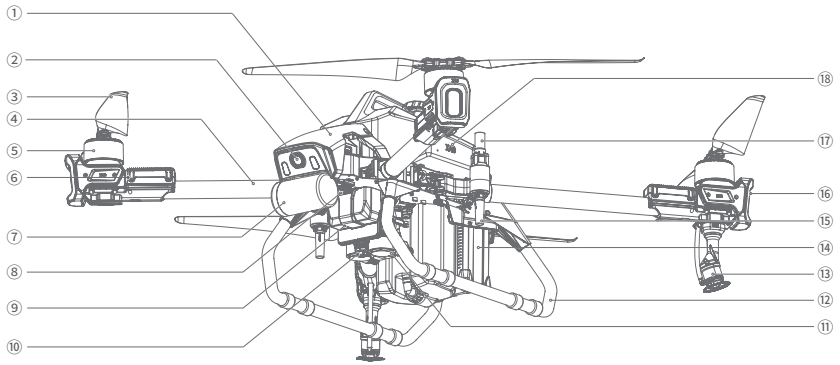

(Above) Figure 1: Airframe Module Structure 1

(Below) Figure 2: Airframe Module Structure 2

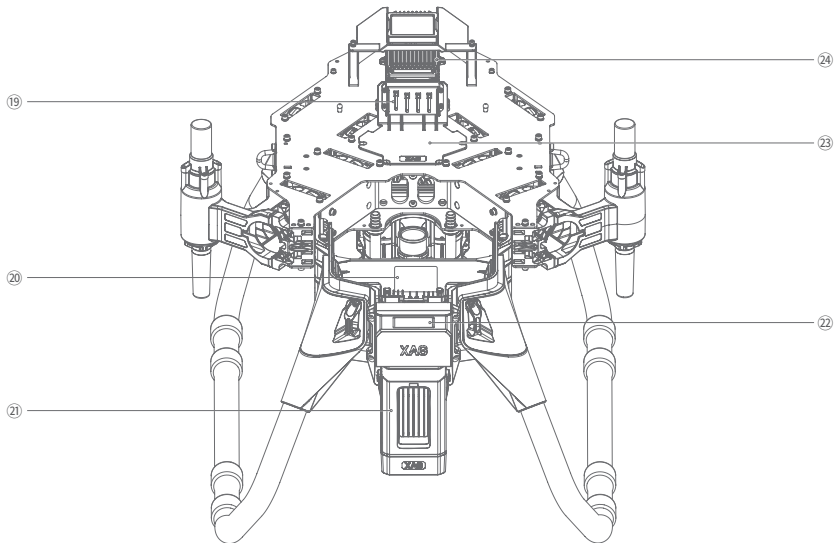

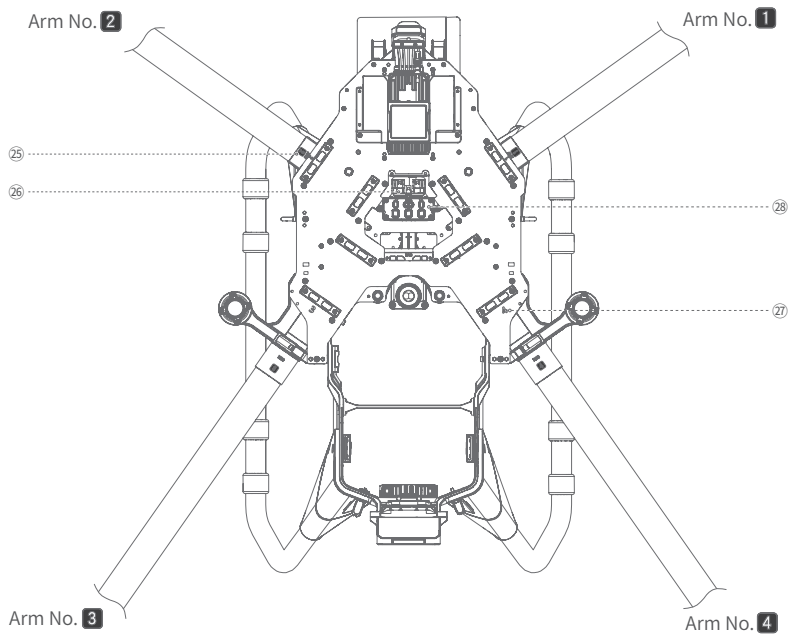

(Below) Figure 3: Airframe Module Structure 3

- |                                     |                             |                                       |
|-------------------------------------|-----------------------------|---------------------------------------|
| ① Head Cover                        | ⑪ Peristaltic Pump          | ⑳ RealTerra System                    |
| ② PSL Camera                        | ⑫ Landing Gear              | ㉑ Flight Status Indicator             |
| ③ Propeller                         | ⑬ Nozzle                    | ㉒ Central Cabin Cover                 |
| ④ Arm                               | ⑭ Smart Battery             | ㉓ Super X4 Intelligent Control System |
| ⑤ Motor                             | ⑮ 2.4GHz Antenna            | ㉔ Arm Position Number                 |
| ⑥ ESC (Electronic Speed Controller) | ⑯ Spraying Status Indicator | ㉕ Spraying Hub                        |
| ⑦ Dynamic Radar                     | ⑰ RTK Antenna               | ㉖ Airframe Position Number            |
| ⑧ Terrain Sensor                    | ⑱ Liquid Tank               | ㉗ ESC Hub                             |
| ⑨ Spraying Hub Housing              | ⑲ Liquid Tank Sensor Patch  |                                       |
| ⑩ Searchlight                       | ㉘ Airframe Nameplate        |                                       |



There are labels on the upper plate of the airframe and the aluminium sleeves of arms. The numbers correspond to the position numbers of arms. 1 for **1**; 2 for **2**; 3 for **3**; 4 for **4**.

# Airframe Assembly

## Preparation

### Remove Spraying Hub Housing

Remove Spraying Hub Housing by unscrewing its 6 screws (2 on the top and 2 on both left side and right side)

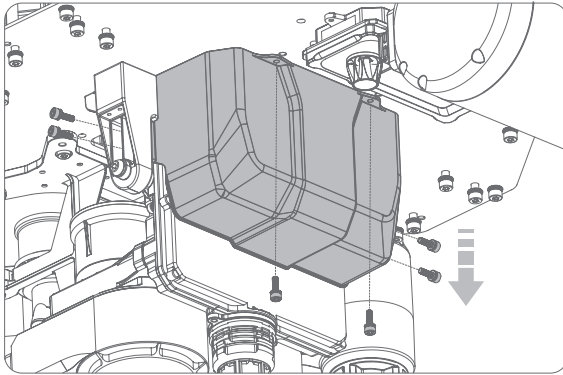

### Remove Central Cabin Cover and Arm Bracket

Pull off the Liquid Tank Sensor Cable on the Spraying Hub.

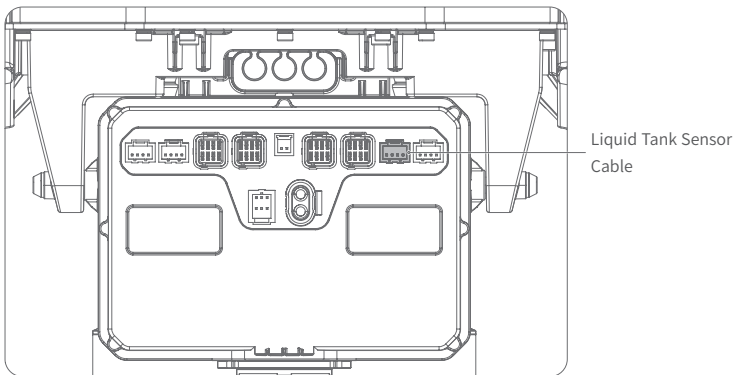

Remove 8 Arm Brackets and Central Cabin Cover.

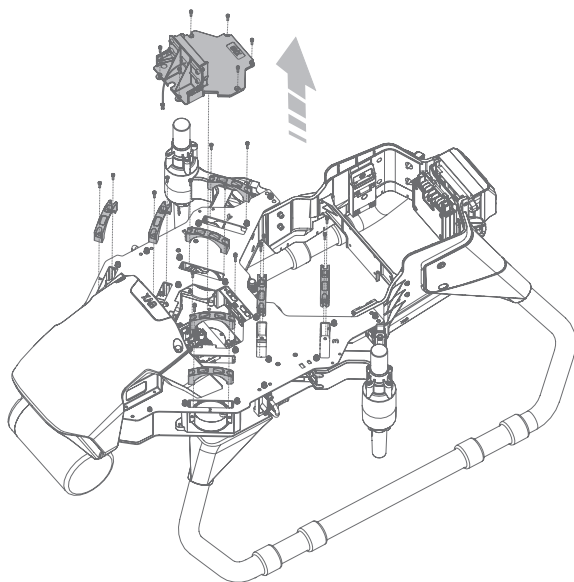



## Arms Assembly

Put the wire into the Arm. By matching the Arm Position Number to the Airframe Position Number, insert the Arm into the Airframe and fit the Arm Bracket.

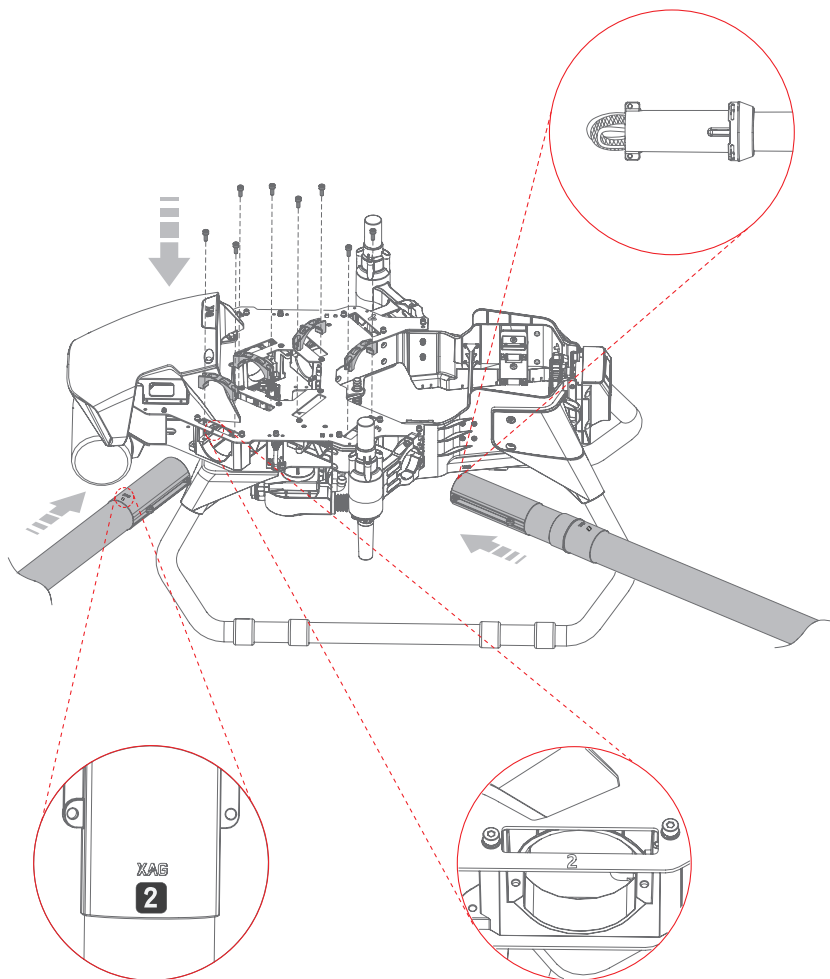

## Cable Connection

### Connect ESC Power Cables

Upon Arms assembly, push the ESC Power Cables of Arm No.1 & No.2 into the hole of the Bottom Central Compartment and connect to those of arm No.3 & No.4. (The red connector fits only to the other red connector while the black one connects to the other black one).

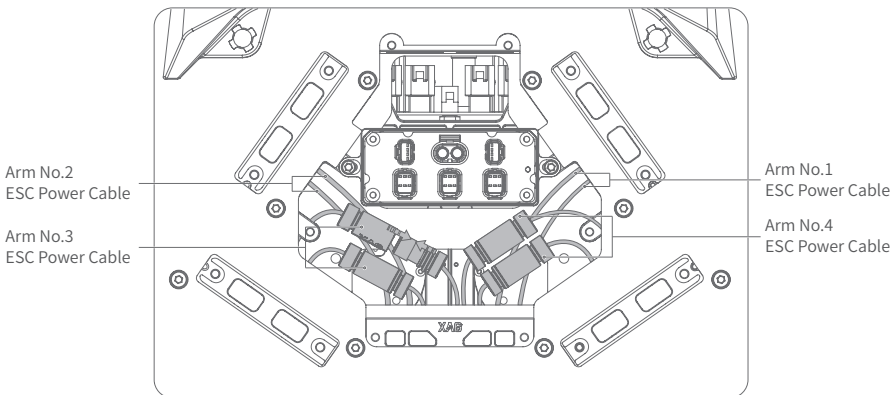

Lock ESC Power Cables of Arm No.3 & No.4 with Fastener.

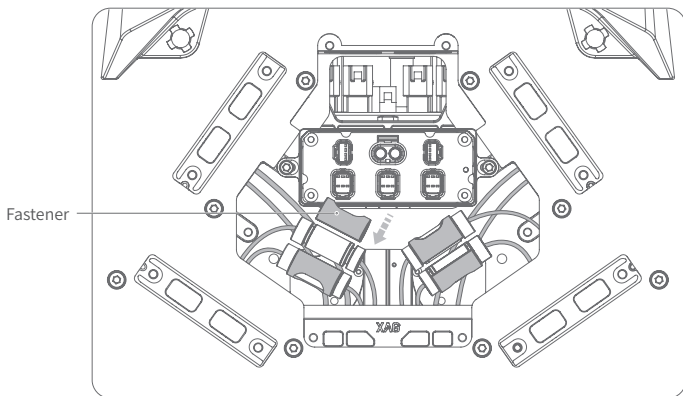

### Warning

⚠ Please remove the Fastener preceding connection of ESC Power Cables of Arm No.1 & No.2 and lock the Fastener back upon connection lest the connector get loose.

Tighten connectors on both sides with cable ties upon the connection between Power Cables of Arm No.1 & No.2 in the Bottom Central Compartment. (The red connector fits only to the other red connector while the black one connect to the other black one)

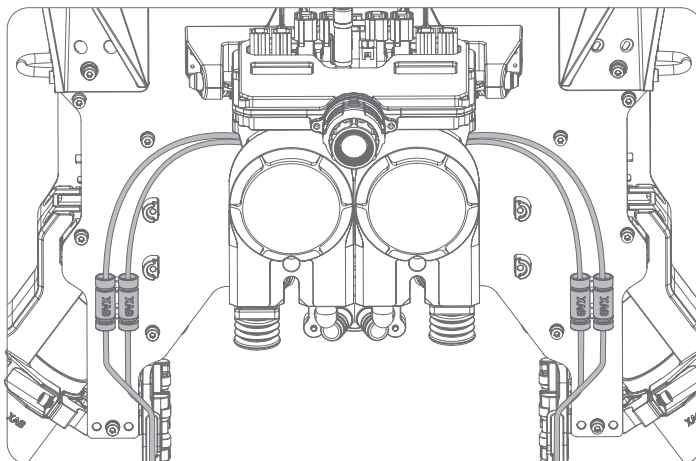

#### Connect Signal Cable of Flight Indicator and Sprayer

Pull the Flight Indicator Signal Cables of Arm No.1 and Arm No.2, plus those of the lights and sprayers of Arm No.3 and Arm No.4 through the hole on the Spraying Hub to the Bottom Central Compartment.

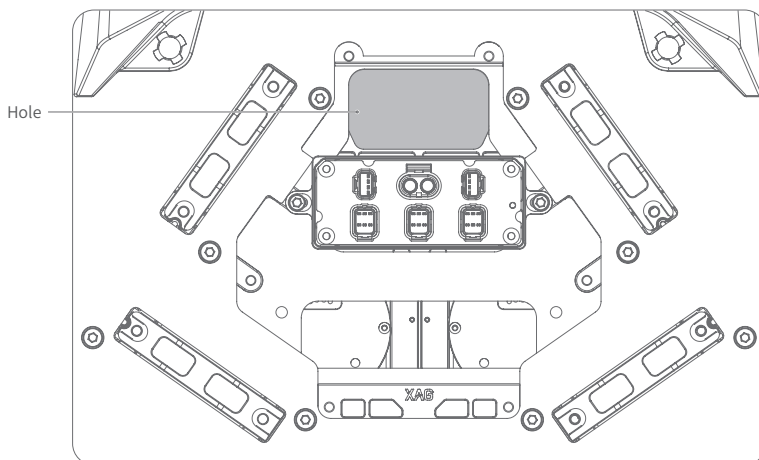

## Connect Male and Female Connectors of Flight Indicator

Before connecting the Flight Indicator Signal Cables, match the Female Connector of Arm No.1 to the Male Connector of Arm No.4 and match the Female Connector of Arm No.2 to the Female Connector of Arm No.3.

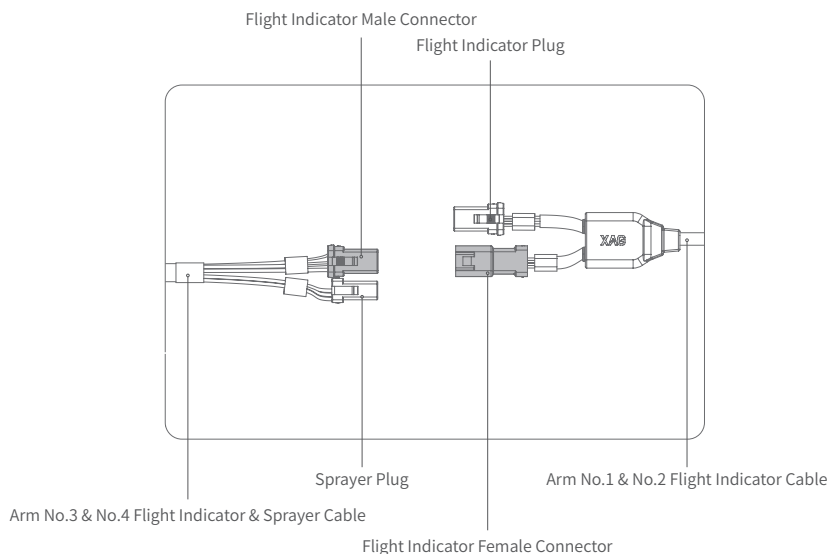

## Connect Cable of Flight Indicator and Sprayer

Upon connection of Flight Indicator Signal Cables between Arm No.1 & No.4 and Arm No.2 & No.3, insert the Flight Indicator Plug of Arm No.1 and that of Arm No.2 into Right LED Indicator LED\_R and Left LED Indicator LED\_L respectively.

Insert sprayer plug of Arm No.3 and that of Arm No.4 into Left sprayer ATO\_L and Right sprayer ATO\_R respectively.

