

Shenzhen Ruitong Qianye Technology Co., Ltd

1.4 Operating Temperature : -25°C~85°C

2.Test instrument : L:创达 1068+1310;DCR:502BC;SIZE:Callipers

3. Bill of Material

NO	Item	Material
1	WIRE	φ 0.08*105P 2UEW-
2	FERRITE	43.5*5.3*1 L-shaped double slot perforated ferrite hard magnetic tape double-sided adhesive
3	GLUE	Water-based white glue
4	SOLDER	HQ-996/JS-996
5	Tin	Thousand Island Pure Tin
6	High temperature adhesive	8mm high-temperature adhesive paper
7		
8		

三 . CIRCUIT DIAGRAM

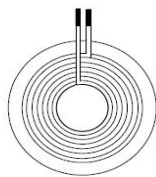

N1



Unit : MM

四 . OUTSIDE DIAGRA

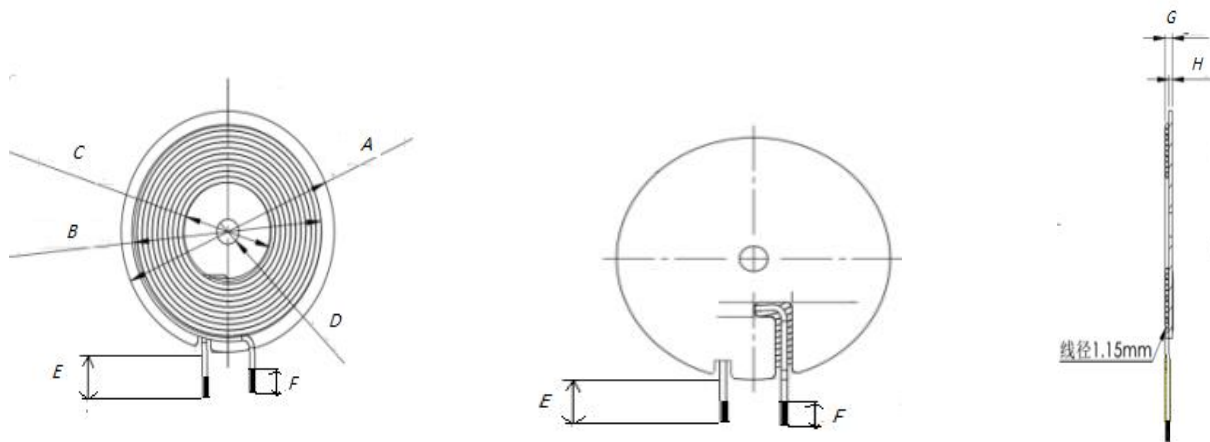

Note: The coil outlet position should not be covered with high-temperature adhesive tape, and the front of the magnetic film should be covered with black film and the back should be covered with double-sided adhesive tape.

Standard	A	B	C	D	E	F	G	
STD	43.5±0.5	39±0.5	13.4±0.3	5.3±0.5	20±2	3±1	2.0±0.2	

Unit : MM

五 . PACKAGE

5.1 Packing pictures:

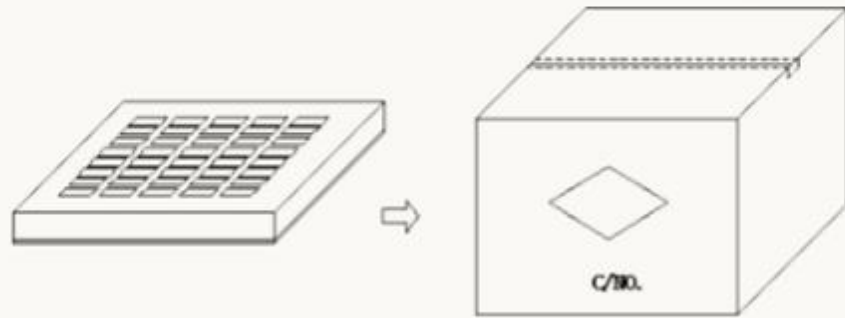

5.2 Packing Quantity:

Item	Quantity	Material
Box	350 Pcs	345*330*50 mm
Big Carton	1750 Pcs	360*340*280 mm

5.3 *The packaging shall be based on the existing packing plate and the actual delivery package shall prevail .If there is any requirement,we can customize it.*

六、Storage and Use condition

6.1 Storage condition

6.1.1

Recommended keeping conditions: $-25^{\circ}\text{C} \sim 85^{\circ}\text{C}$, 70%RH (Max.)

6.1.2

Storage life : Within the limits of six months from being produced.

6.2 Use condition

Use condition limit: $T=-25^{\circ}\text{C} \sim 85^{\circ}\text{C}$, $\text{RH} \leq 90\%$.