

# 承 認 書

## SPECIFICATION FOR APPROVAL

客 戶:  
CUSTOMER:

客 戶 料 號:  
CUST P/N:

音 澤 料 號:  
FINE P/N:

產 品 型 號:  
DESC:

日 期:  
DATE:

版 本:  
Version:

**A11 开槽单线圈 0.08\*105P\*10TS\*6.5UH**

**G50MMX0.9MM**

**2021/05/07**

**A.0**

擬制 PREPARED BY	審核 CHECKED BY	批准 APPROVED BY	客戶承認 CUSTOMER APPROVE
马莉	但可清	但可清	

## 东莞市音泽电子科技有限公司

Dongguan Yinze Electronic Technology Co., Ltd

工廠地址：东莞市石排镇埔心村莲湖路四街一号

Factory address: No. 1, Lianhu Road, Puxin Village, Shipai Town, Dongguan City

但可清 TEL: 18617251159



# SPECIFICATION

產品型號: DESC	<b>A11 开槽单线圈</b> <b>0.08*105P*10TS*6.5UH</b>	版本 Rev: A.0	客戶 CUST: 客戶料号 CUST P/N:	
---------------	---	----------------	----------------------------	--

一、尺寸 DIMENSION:(mm)

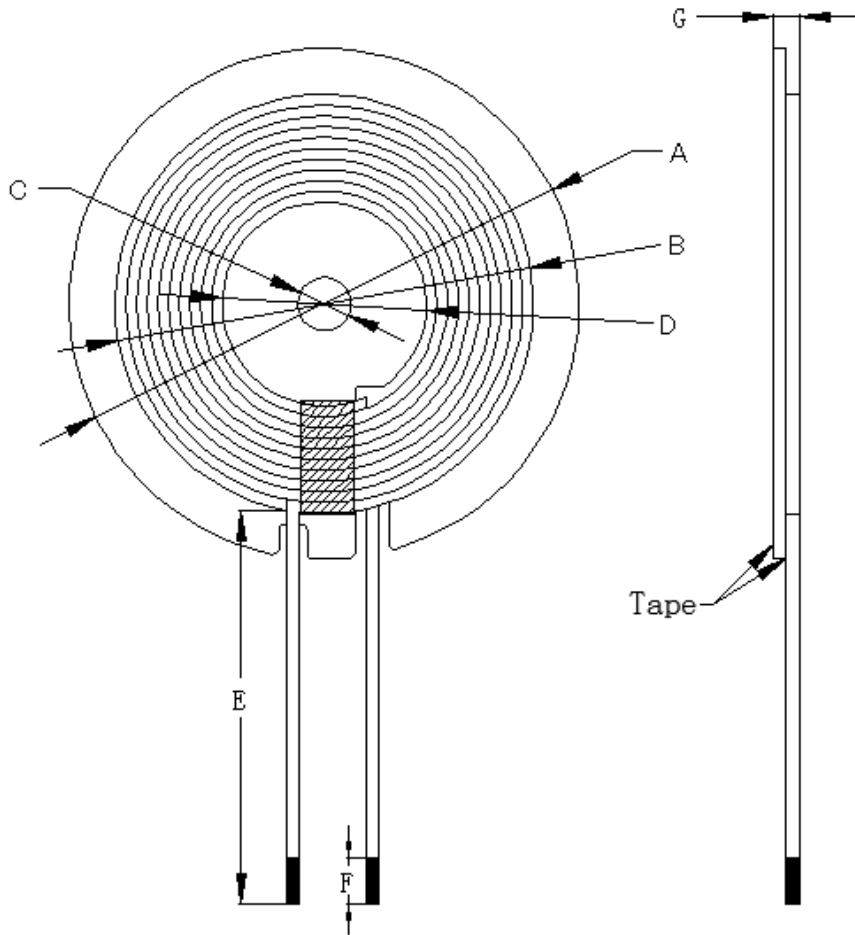

A	50±1
B	42.5±1
C	5.3±0.5
D	20.5±0.5
E	10±2
F	5±2
G	2.3±0.5
H	
J	
K	

注:

- 1.交叉出线;
- 2.线圈贴圆形开槽硬磁片, 磁片尺寸 50±1mm

Concentrate:

1. Cross out;
2. The coil is attached to a round slotted hard magnetic sheet, and the size of the magnetic sheet is 50±1mm

二、原理图 SCHEMATIC DIAGRAM:

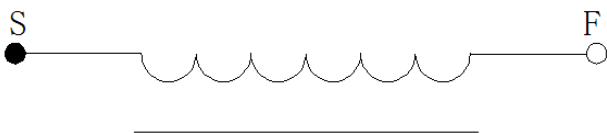

## 三、绕线参数 Winding Specification:

序号 NO.	端子 TERMINAL		线径 WIRE	圈数 Turns	绕线方向 Winding Direction
1	S	F	热风线 0.08*105P	10Ts	CCW

## 四、电气特性 ELECTRICAL CHARACTERISTICS:

温度 TEMPERATURE:25±10°C, 湿度 RELATIVE HUMIDITY:65±20%

序号 NO.	项目 ITEM	端子 TERMINAL	标准 SPECIFICATION	测试条件 TEST FREQUENCY	测试仪器 TEST EQUIPMENTS
1	IND.	S-F	3.8uH ±10%单独线圈	100KHz/1.0V	LCZ METER 1062B
2	IND.	S-F	6.5uH ±10%加磁片	100KHz/1.0V	LCZ METER 1062B
3	DCR	S-F	≤480mΩ		LCZ METER 502B

拟制/日期 PREPARED BY/DATE

审核/日期 CHECKED BY/DATE

马莉 2021.05.07

但可清 2021.05.07