

# SPECIFICATION

產品型號: DESC	Φ25x38-6.5uH-40mm	版本 Rev: A.0	客戶 CUST: 客戶料号 CUST P/N:	<b>XXX</b>
---------------	-------------------	----------------	----------------------------	------------

一、尺寸 DIMENSION:(mm)

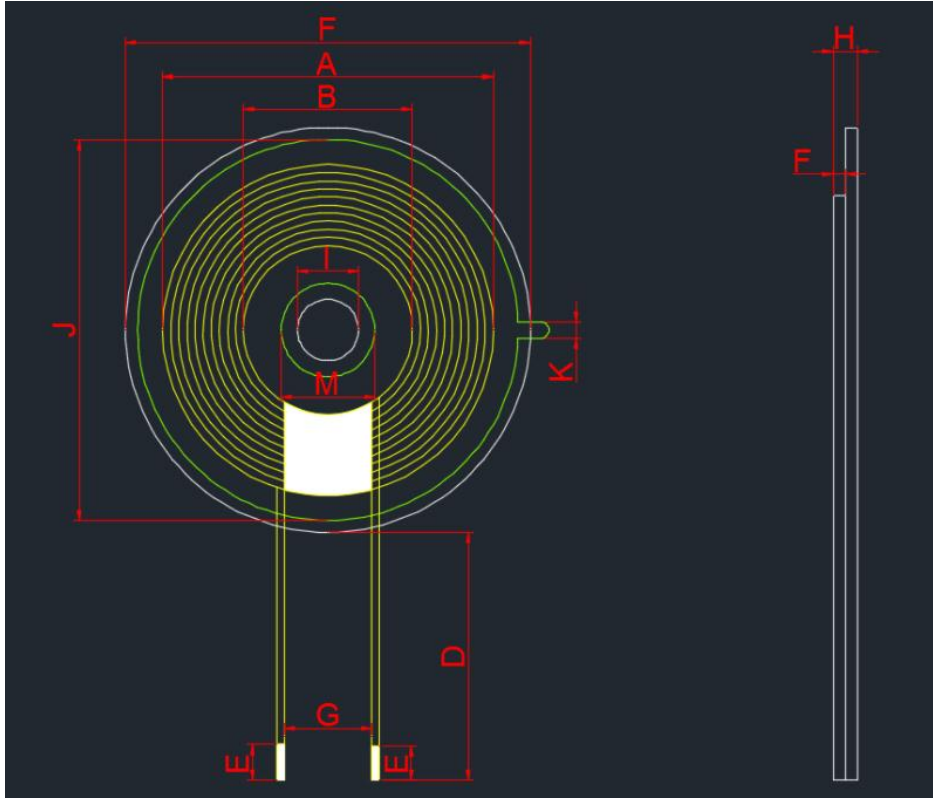

A	39±1.5
B	20.5±0.5
C	1.25 Max
D	40±3
E	3±1
F	45±1.5
G	10.0 ref
H	2.2 Max
I	5 ref
M	5.0 ref
J	43±1

注:

- 1.交叉出线;
- 2.出线位置缠 8mm(ref)宽度高温胶纸 1-2Ts;
- 3.线圈贴圆形硬磁片, 磁片尺寸 50±0.7mm,内孔 5.3mm,厚度为 0.8±0.2mm。

二、原理图 SCHEMATIC DIAGRAM:



三、绕线参数 Winding Specification:

序号 NO.	端子 TERMINAL		线径 WIRE	圈数 Turns	绕线方向 Winding Direction
1	S	F	丝包线 1±0.15	10Ts	CCW

四、电气特性 ELECTRICAL CHARACTERISTICS:

温度 TEMPERATURE:25±10°C, 湿度 RELATIVE HUMIDITY:65±20%

序号 NO.	项目 ITEM	端子 TERMINAL	标准 SPECIFICATION	测试条件 TEST FREQUENCY	测试仪器 TEST EQUIPMENTS
1	IND.	S-F	3.8uH ±20%单独线圈	100KHz/1.0V	LCZ METER 1062B
2	IND.	S-F	6.3uH ±10%加磁片	100KHz/1.0V	LCZ METER 1062B
3	DCR	S-F	≤70mΩ		LCZ METER 502B

擬制/日期 PREPARED BY/DATE

審核/日期 CHECKED BY/DATE