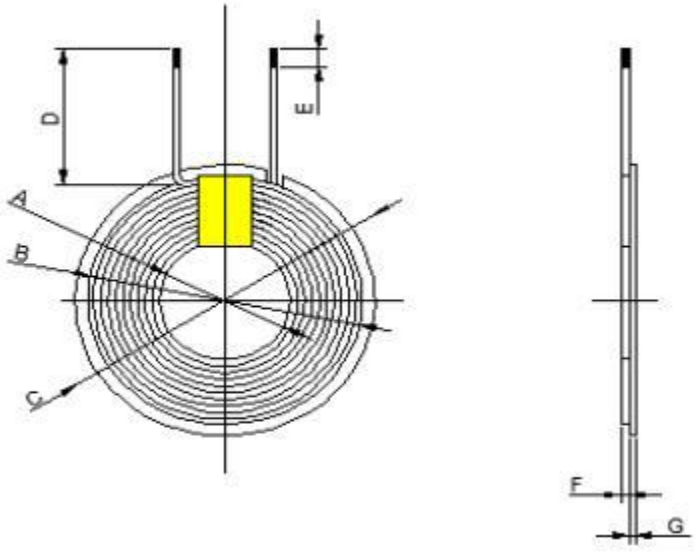

SHENZHEN YONGMAN DIGITAL CO.,LTD

specification

Document number		name of a part	Wireless charging and transmission coil module				
product size	Φ 50* Φ 5*H2.5	Adhesion mode	Acetone self-adhesive				
						A	20.5 ± 0.5
						B	41.0 ± 1.0
						C	50.0 ± 0.5
						D	50 ± 2
						E	5MAX
						F	1.9MAX
						G	0.8 ± 0.1
						H	2.5M AX
						unit:MM	
wire stock	At 0.07 * 100 shares		Wire way	Single line fold circle type	have pour	The coil is in the counter clockwise direction	
number of turns	10Ts						
Magnetic sheet size	Φ 50* Φ 5*0.8	L	$6.8 \pm 10\%$				
Coil size	Φ 41.0*20.5	Test frequency	100KHZ	test mode	Series test		
visitor one-panelled							

door meanin g See							
tabulat ion		examine and verify		affirm	chen lihua	date	20240620