

Product Name: LTE Module	Report No: FCC022022-05502RF12(c)
Product Model: TOBY-L3414	Security Classification: Open
Version: V1.0	Total Page: 44

Testing Report

Prepared By:	Checked By:	Approved By:	
Stone Tang	Randy Lv	Daniel Chen	
<i>Stone Tang</i>	<i>Randy Lv</i>	<i>Daniel Chen</i>	

FCC Radio Test Report

FCC ID: 2A3Z6TOBYL3414

According to

**47 CFR FCC Part 24E
47 CFR FCC Part 2
ANSI C63.26**

Equipment : LTE Module
Model No. : TOBY-L3414
Trademark : TASHANG
Product No. : 20220820018527
Applicant : Tashang Semiconductor(Shanghai) Co., Ltd.
Room 818, Building 4, No.89, Sanshahong Road, Chengqiao Town,
Chongming District, Shanghai

- The test result referred exclusively to the presented test model /sample.
- Without written approval of TIRT Inc. the test report shall not reproduced except in full.
- Date of Receipt: 2022.09.05
- Date of Test: 2022.09.06-2022.09.30
- Issued Date: 2022.10.20

Lab: Beijing TIRT Technology Service Co.,Ltd Shenzhen
Add: Plant 3, Gongjindianzi, Shatian, Kengzi Street, Pingshan District, Shenzhen,
Guangdong, China
TEL: +86-0755-27087573

Table of Contents

REPORT ISSUED HISTORY	5
1 . GENERAL SUMMARY	6
2 . SUMMARY OF TEST RESULTS	7
2.1 TEST FACILITY	8
2.2 MEASUREMENT UNCERTAINTY	8
3 . GENERAL INFORMATION	9
3.1 GENERAL DESCRIPTION OF EUT	9
3.2 DESCRIPTION OF TEST MODES AND TEST CONDITION	10
3.3 EUT TEST CONDITIONS	10
3.4 BLOCK DIGRAM SHOWING THE CONFIGURATIONOFSYSTEMTESTED	11
3.5 DESCRIPTION OF SUPPORT UNITS	11
4 . TEST RESULT	12
4.1 OUTPUT POWER MEASUREMENT	12
4.1.1 LIMIT	12
4.1.2 TEST PROCEDURE	12
4.1.3 TEST SETUP LAYOUT	13
4.1.4 TEST DEVIATION	14
4.1.5 TEST RESULTS	14
4.2 OCCUPIED BANDWIDTH MEASUREMENT	15
4.2.1 APPLICABLE STANDARD	15
4.2.2 TEST PROCEDURE	15
4.2.3 TEST SETUP LAYOUT	15
4.2.4 TEST DEVIATION	15
4.2.5 TEST RESULTS	15
4.3 CONDUCTED EMISSIONS MEASUREMENT	16
4.3.1 LIMIT	16
4.3.2 APPLICABLE STANDARD	16
4.3.3 TEST PROCEDURES	16
4.3.4 TEST SETUP LAYOUT	16
4.3.5 TEST DEVIATION	16
4.3.6 TEST RESULTS	16
4.4 RADIATED EMISSIONS MEASUREMENT	17
4.4.1 LIMIT	17
4.4.2 TEST PROCEDURES	17
4.4.3 TEST SETUP LAYOUT	18
4.4.4 TEST DEVIATION	19
4.4.5 TEST RESULTS	19

Table of Contents

4.5 BAND EDGE MEASUREMENT	20
4.5.1 THE REQUIREMENT FOR SECTION § 22.917(A), §24.238(A)	20
4.5.2 TEST PROCEDURES	20
4.5.3 TEST SETUP LAYOUT	20
4.5.4 TEST DEVIATION	20
4.5.5 TEST RESULTS	20
4.6 PEAK TO AVERAGE RATIO MEASUREMENT	21
4.6.1 LIMIT	21
4.6.2 TEST PROCEDURES	21
4.6.3 TEST SETUP LAYOUT	21
4.6.4 TEST DEVIATION	21
4.6.5 TEST RESULTS	21
4.7 FREQUENCY STABILITY MEASUREMENT	22
4.7.1 LIMIT	22
4.7.2 TEST PROCEDURES	22
4.7.3 TEST SETUP LAYOUT	22
4.7.4 TEST DEVIATION	22
4.7.5 TEST RESULTS	22
5. LIST OF MEASUREMENT EQUIPMENTS	23
APPENDIX A – RF OUTPUT POWER	25
TEST DATA:	25
APPENDIX B - OCCUPIED BANDWIDTH	26
TEST DATA:	26
TEST GRAPHS	27
APPENDIX C - CONDUCTED EMISSIONS	29
TEST DATA:	29
TEST GRAPHS	30
APPENDIX D - RADIATED EMISSION (9KHZ TO 30MHZ)	32
APPENDIX E - RADIATED EMISSION(30MHZ-1GHZ)	33
APPENDIX F - RADIATED EMISSION (ABOVE 1GHZ)	36
APPENDIX G - BAND EDGE	38
TEST GRAPHS	39
APPENDIX H - PEAK TO AVERAGE RATIO	41
TEST GRAPHS	42
APPENDIX I - FREQUENCY STABILITY	44

REPORT ISSUED HISTORY

Report Version	Description	Issued Date
R00	Original Issue.	Oct. 20, 2022
R01	Revised issue	Nov. 03, 2022

1. GENERAL SUMMARY

Equipment : LTE Module
Brand Name : TASHANG
Test Model : TOBY-L3414
Series Model : /
Applicant : Tashang Semiconductor(Shanghai) Co., Ltd.
Address : Room 818, Building 4, No.89, Sanshahong Road, Chengqiao Town,
Chongming District, Shanghai, China
Manufacturer : Tashang Semiconductor(Shanghai) Co., Ltd.
Address : Room 818, Building 4, No.89, Sanshahong Road, Chengqiao Town,
Chongming District, Shanghai, China
Standard(s) : FCC Rules and Regulations Part 24 Subpart E - Personal Communication
Services
ANSI C63.26:2015
47 CFR FCC Part 2
ANSI/TIA/EIA-603-E-2016
FCC KDB 971168 D01 Power Meas License Digital Systems v03r01

The above equipment has been tested and found compliance with the requirement of the relative standards by TIRT Inc.

2. SUMMARY OF TEST RESULTS

Test procedures according to the technical standard(s):

FCC Rules	Description of Test	Result
Section 15.207	N/A	N/A
§2.1046; § 24.232 (c)	RF Output Power	Compliant
§ 2.1049; § 24.238	99% & -26 dB Occupied Bandwidth	Compliant
§ 2.1051, § 24.238 (a)	Spurious Emissions at Antenna Terminal	Compliant
§ 2.1053 § 24.238 (a)	Field Strength of Spurious Radiation	Compliant
§ 24.238 (a)	Out of band emission, Band Edge	Compliant
§ 2.1055 § 24.235	Frequency stability vs. temperature Frequency stability vs. voltage	Compliant
KDB 971168 D01 Power Meas License Digital Systems v03r01	Peak to average ratio	Compliant

2.1 TEST FACILITY

Company:	Beijing TIRT Technology Service Co.,Ltd Shenzhen
Address:	101, 3 # Factory Building, Gongjin Electronics Shatin Community, Kengzi Street, Pingshan District, Shenzhen, China
CNAS Registration Number:	CNAS L14158
A2LA Registration Number:	6049.01
FCC Accredited Lab. Designation Number:	CN1309
FCC Test Firm Registration Number:	825524
Telephone:	+86-0755-27087573

2.2 MEASUREMENT UNCERTAINTY

ISO/IEC 17025 requires that an estimate of the measurement uncertainties associated with the emissions test results be included in the report. The measurement uncertainties given below are based on a 95% confidence level (based on a coverage factor (k=2))

The TIRT measurement uncertainty as below table:

Uncertainty	
Parameter	Uncertainty
Occupied Channel Bandwidth	±142.12kHz
RF power conducted	±0.74dB
RF power radiated	±3.25dB
Spurious emissions, conducted	±1.78dB
Spurious emissions, radiated (30MHz ~ 1GHz)	±4.6dB
Spurious emissions, radiated (1GHz ~ 18GHz)	±4.9dB
Conduction Emissions(150kHz~30MHz)	±3.1dB
Humidity	±4.6%
Temperature	±0.7°C
Time	±1.25%

Note: Unless specifically mentioned, the uncertainty of measurement has not been taken into account to declare the compliance or non-compliance to the specification.

3. GENERAL INFORMATION

3.1 GENERAL DESCRIPTION OF EUT

Equipment	LTE Module	
Brand Name	TASHANG	
Test Model	TOBY-L3414	
Series Model	/	
Model Difference(s)	/	
Software Version	M31.04.11.01.01	
Hardware Version	V1.0	
Antenna Type	External Antenna	
Antenna Gain	GSM 1900	0.43 dBi
Modulation Type	GMSK for GSM/GPRS 8PSK for EGPRS	
GPRS Class	Multi-Class 12	
Operation Frequency	GSM 1900: 1850.2-1909.8 MHz	300 Channels
Max. ERP Power	GSM/GPRS 1900:	30.48 dBm
	EDGE 1900:	26.38 dBm
Normal Test Voltage	3.8Vdc	
Extreme Test Voltage	3.3 to 4.2Vdc	
Operating Temperature	-40 °C to 85 °C	

Note:

1. For a more detailed features description, please refer to the manufacturer's specifications or the user's manual.

3.2 DESCRIPTION OF TEST MODES AND TEST CONDITION

Pre-Scan has been conducted to determine the worst-case mode from all possible combinations between available modulations, data rates, XYZ axis and antenna ports. The worst case was found when positioned on X-plane for EIRP and X-axis for radiated emission. Following channel(s) was (were) selected for the final test as listed below:

Test Item	Tested Channel	Test Mode
EIRP	PCS1900: 512, 661, 810	GSM, GPRS, EGPRS
RF Output Power	PCS1900: 512, 661, 810	GSM, GPRS, EGPRS
Conducted Emission	PCS1900: 512, 661, 810	GSM, GPRS, EGPRS
Radiated Emission	PCS1900: 512, 661, 810	GSM, GPRS, EGPRS
Band Edge	PCS1900: 512, 810	GSM, GPRS, EGPRS
Peak to Average Ratio	PCS1900: 512, 661, 810	GSM, GPRS, EGPRS
Frequency Stability	PCS1900: 512, 661, 810	GSM, GPRS, EGPRS

3.3 EUT TEST CONDITIONS

Test Item	Temperature	Humidity	Test Voltage	Tested By
EIRP	24.2°C	56%	3.8V DC	Stone Tang
RF Output Power	24.6°C	55%	3.8V DC	Stone Tang
Occupied Bandwidth	24.6°C	55%	3.8V DC	Stone Tang
Conducted Emission	24.6°C	55%	3.8V DC	Stone Tang
Radiated Emission	24.2°C	55%	3.8V DC	Stone Tang
Band Edge	24.2°C	55%	3.8V DC	Stone Tang
Peak to Average Ratio	24.6°C	55%	3.8V DC	Stone Tang
Frequency Stability	Normal and Extreme	Normal and Extreme	Normal and Extreme	Stone Tang

3.4 BLOCK DIGRAM SHOWING THE CONFIGURATION OF SYSTEM TESTED

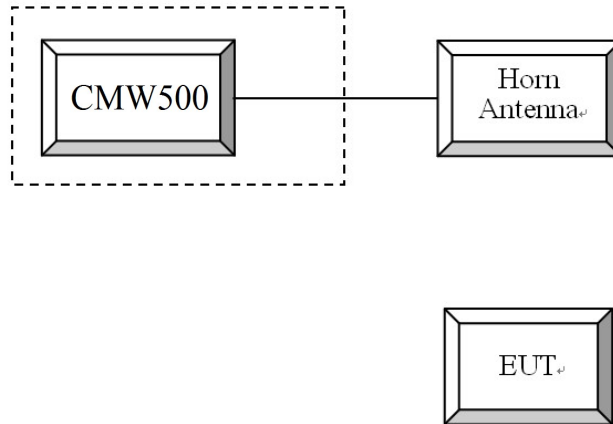

3.5 DESCRIPTION OF SUPPORT UNITS

The EUT has been tested as an independent unit together with other necessary accessories or support units. The following support units or accessories were used to form a representative test configuration during the tests.

Item	Equipment	Mfr/Brand	Model/Type No.	Series No.
1	Wideband Radio Communication Tester	Rohde & Schwarz	CMW500	1201.0002K50-116064

4. TEST RESULT

4.1 OUTPUT POWER MEASUREMENT

4.1.1 LIMIT

The substitution method, in ANSI/TIA-603-E-2016, was used for ERP/EIRP measurement, and the spectrum analyzer configuration follows KDB 971168 D01 Power Meas. License Digital Systems v03. The ERP of mobile transmitters must not exceed 7 Watts (Cellular Band) and the EIRP of mobile transmitters are limited to 2 Watts (PCS Band).

4.1.2 TEST PROCEDURE

The measurements procedures specified in ANSI/TIA-603-E-2016 were applied.

In an anechoic antenna test chamber, a half-wave dipole antenna for the frequency band of interest is placed at the reference centre of the chamber. An RF Signal source for the frequency band of interest is connected to the dipole with a cable that has been constructed to not interfere with the radiation pattern of the antenna. A known (measured) power (P_{in}) is applied to the input of the dipole, and the power received (P_r) at the chamber's probe antenna is recorded.

The relevant equation for determining the ERP or EIRP from the conducted RF output power measured using the guidance provided above is:

$$ERP/EIRP = SGLevel - P_{cl} + G_a$$

where:

ERP/EIRP = effective or equivalent radiated power, respectively (expressed in the same units as SGLevel, typically dBW or dBm);

SGLevel = Signal generator output power or PSD, in dBm or dBW;

G_a = gain of the transmitting antenna, in dBd (ERP) or dBi (EIRP);

P_{cl} = signal attenuation in the connecting cable between the transmitter and antenna.

The EUT is substituted for the dipole at the reference centre of the chamber and a scan is performed to obtain the radiation pattern.

From the radiation pattern, the co-ordinates where the maximum antenna gain occurs are identified.

The EUT is then put into continuously transmitting mode at its maximum power level. Power mode measurements are performed with the receiving antenna placed at the coordinates determined in Step 3 to determine the output power as defined in Rule 24.232 (b) and (c). The "reference path loss" from Step1 is added to this result.

This value is EIRP since the measurement is calibrated using a half-wave dipole antenna of known gain (2.15 dBi) and known input power (P_{in}).

ERP can be calculated from EIRP by subtracting the gain of the dipole, $ERP = EIRP - 2.15dBi$.

Both horizontal and vertical antenna polarities were tested and performed pretest to three orthogonal axis. The worst case emissions were reported.

4.1.3 TEST SETUP LAYOUT

Conducted method:

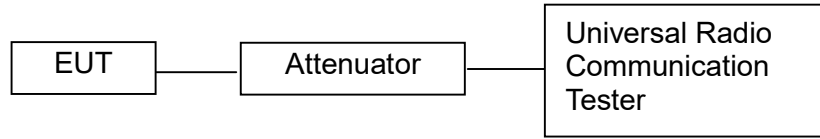

Radiated method:

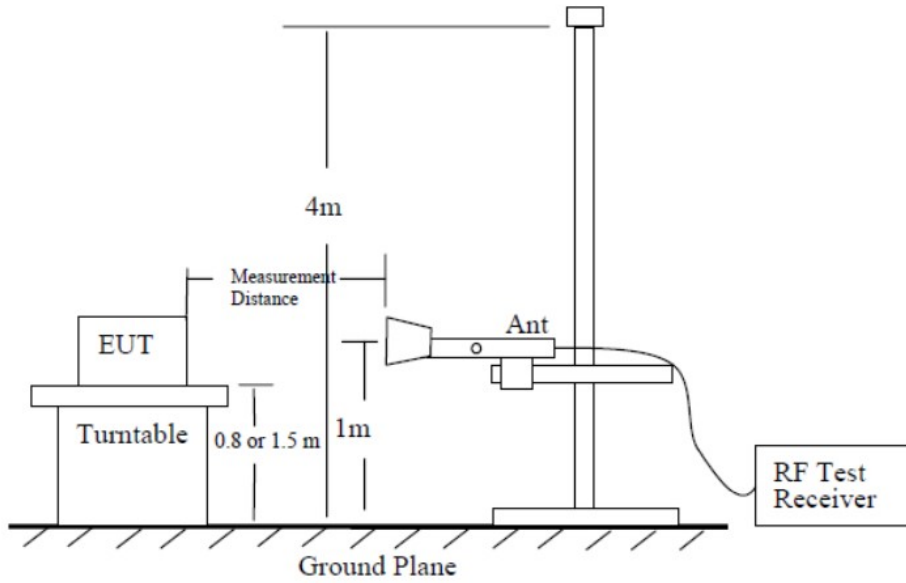

Test site-up for radiated ERP and/or EIRP measurements

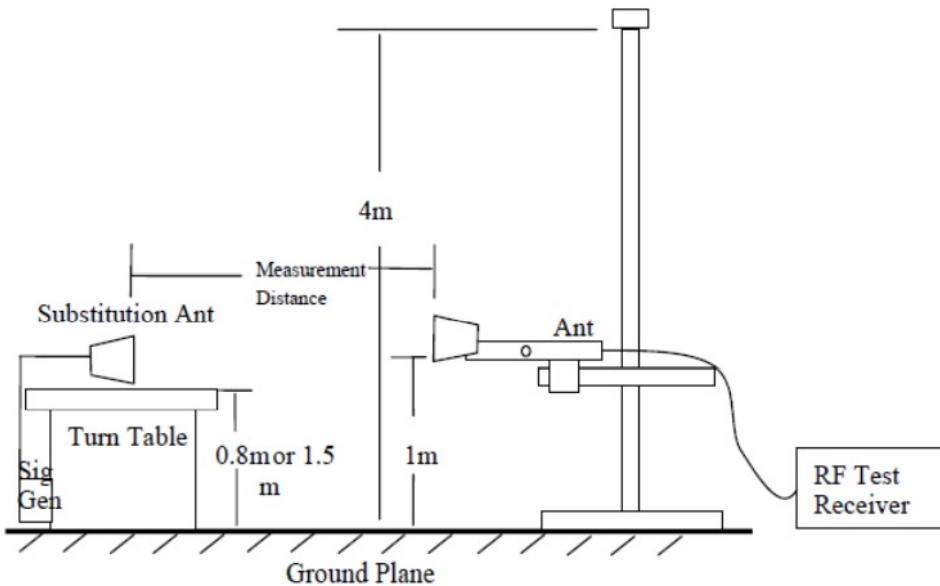

Substitution method set-up for radiated emission

4.1.4 TEST DEVIATION

No deviation

4.1.5 TEST RESULTS

Please refer to the Appendix A.

4.2 OCCUPIED BANDWIDTH MEASUREMENT

4.2.1 APPLICABLE STANDARD

FCC § 2.1049, § 22.917, § 22.905 and § 24.238.

4.2.2 TEST PROCEDURE

The EUT makes a call to the communication simulator. All measurements were done at low, middle and high operational frequency range. The communication simulator station system controlled a EUT to export maximum output power under transmission mode and specific channel frequency. Use OBW measurement function of Spectrum analyzer to measure 99 % occupied bandwidth and 26dB bandwidth.

99% occupied bandwidth&-26dB occupied bandwidth test:

1. Set the resolution bandwidth (RBW) = 10 kHz.
2. Set the video bandwidth (VBW) = 30 kHz.
3. Detector = Peak.
4. Trace mode = max hold.
5. Sweep = auto couple.
6. Allow the trace to stabilize.
7. Measurements are to be performed with the EUT set to the low, middle and high channel of each frequency band.

4.2.3 TEST SETUP LAYOUT

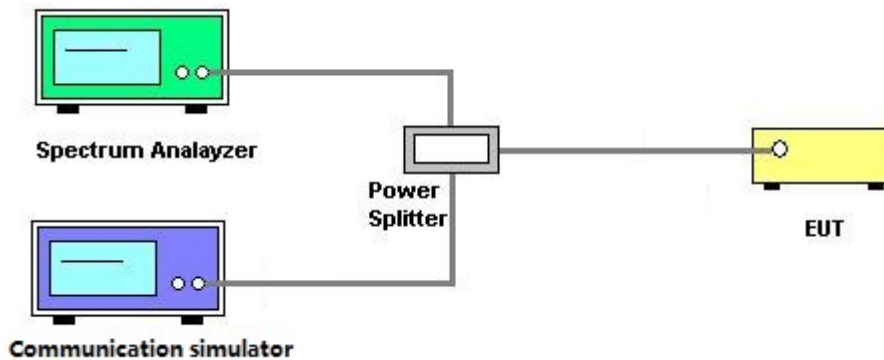

4.2.4 TEST DEVIATION

No deviation

4.2.5 TEST RESULTS

Please refer to the Appendix B.

4.3 CONDUCTED EMISSIONS MEASUREMENT

4.3.1 LIMIT

The power of any emission outside of the authorized operating frequency ranges must be attenuated below the transmitting power (P) by a factor of at least $43 + 10 \log(P)$ dB. The emission limit equal to -13dBm.

4.3.2 APPLICABLE STANDARD

FCC §2.1051, §22.917(a) and §24.238(a).

The spectrum was to be investigated to the tenth harmonics of the highest fundamental frequency as specified in §2.1051

4.3.3 TEST PROCEDURES

1. The testing follows FCC KDB 971168 v03r01 Section 6.0.
2. The EUT was connected to spectrum analyzer and system simulator via a power divider.
3. The band edges of low and high channels for the highest RF powers were measured. Set $RBW \geq 1\%$ EBW in the 1MHz band immediately outside and adjacent to the band edge.
4. Set spectrum analyzer with RMS detector.
5. The RF fundamental frequency should be excluded against the limit line in the operating frequency band.

4.3.4 TEST SETUP LAYOUT

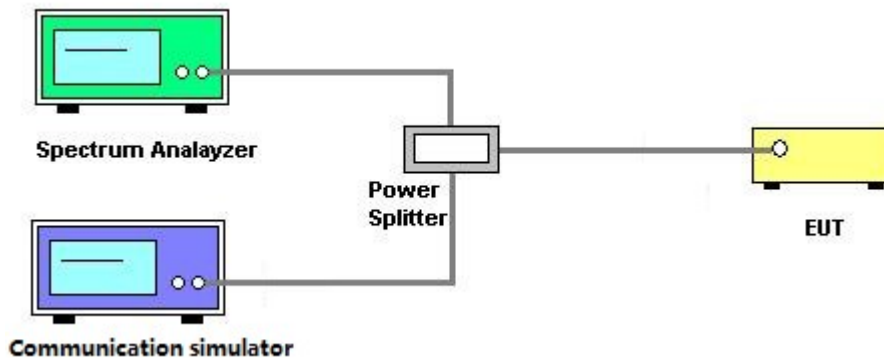

4.3.5 TEST DEVIATION

No deviation

4.3.6 TEST RESULTS

Please refer to the Appendix C.

4.4 RADIATED EMISSIONS MEASUREMENT

4.4.1 LIMIT

The power of any emission outside of the authorized operating frequency ranges must be attenuated below the transmitting power (P) by a factor of at least $43 + 10 \log(P)$ dB. The emission limit equal to -13dBm.

4.4.2 TEST PROCEDURES

1. Substitution method is used for E.I.R.P measurement. In the semi-anechoic chamber, EUT placed on the 0.8m height of Turn Table, rotated the table around 360 degrees to search the maximum radiation power and receiver antenna shall be rotated vertical and horizontal polarization and moved height from 1m to 4m to find the maximum polar radiated power. The "Read Value" is the spectrum reading the maximum power value.
2. The substitution horn antenna is substituted for EUT at the same position and signals generator export the CW signal to the substitution antenna via a TX cable. Rotated the Turn Table and moved receiving antenna to find the maximum radiation power. Adjust output power level of S.G to get a Value of spectrum reading equal to "Read Value " of step a. Record the power level of S.G
3. The bandwidth of test receiver is set at 9kHz in below 30MHz. and set at 120kHz in 30-1000MHz, and 1MHz in above 1000MHz.
The frequency range from 9kHz to 20GHz is checked.
The final measurement in band 9-90kHz, 110-490kHz and above 1000MHz is performed with Average detector. Except those frequency bands mention above, the final measurement for frequencies below 1000MHz is performed with Quasi Peak detector.
Spurious emissions in dB = $10 \lg(\text{TXpwr in Watts}/0.001)$ – the absolute level
Spurious attenuation limit in dB = $43 + 10\text{Log}(P)$ (power out in Watts)

4.4.3 TEST SETUP LAYOUT

Below 30MHz

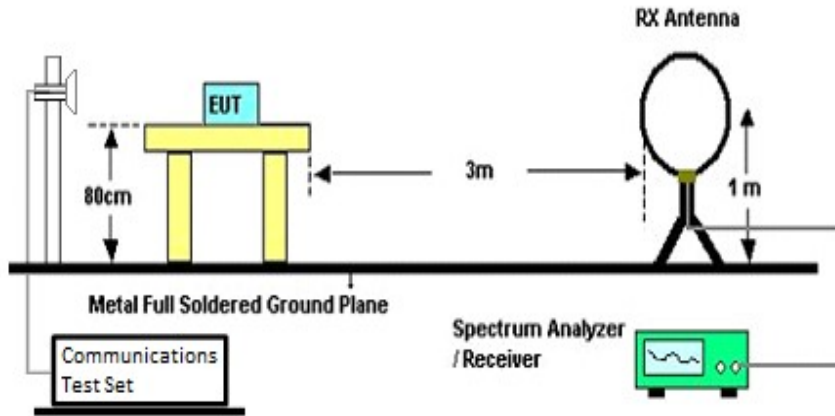

30MHz to 1GHz

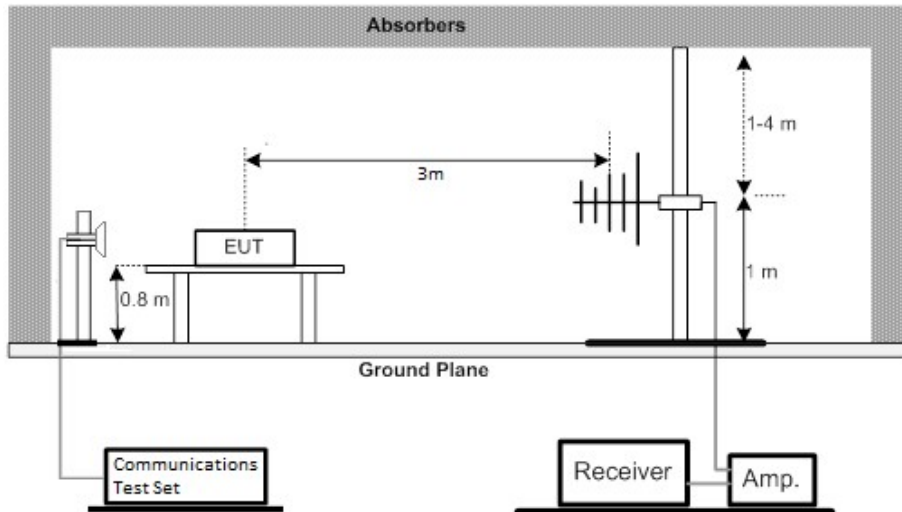

Above 1GHz

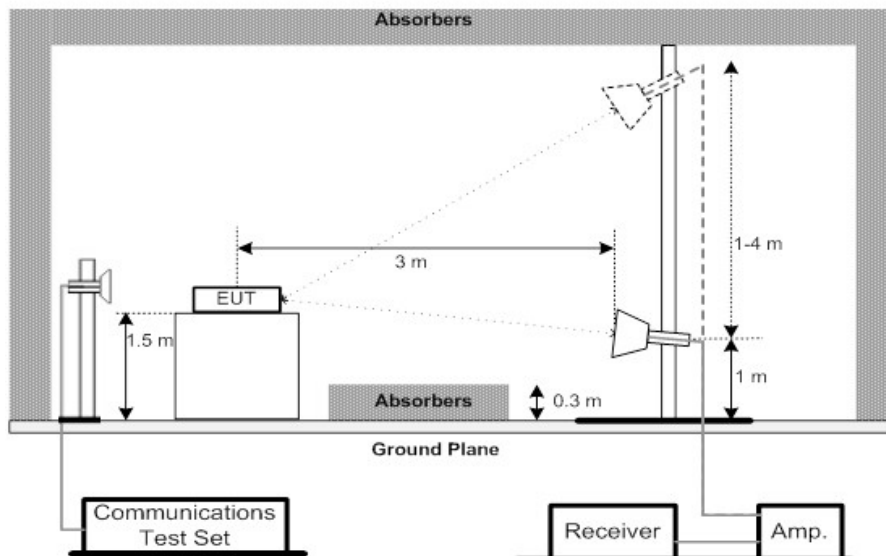

4.4.4 TEST DEVIATION

No deviation

4.4.5 TEST RESULTS

Please refer to the Appendix D, E, F.

4.5 BAND EDGE MEASUREMENT

4.5.1 THE REQUIREMENT FOR SECTION § 22.917(A), §24.238(A)

The Requirement For Section § 22.917(a), §24.238(a)

According to § 22.917(a), the power of any emissions outside of the authorized operating frequency ranges must be attenuated below the transmitting power (P) by a factor of at least $43 + 10 \log(P)$ dB.

According to §24.238(a), the power of any emissions outside of the authorized operating frequency ranges must be attenuated below the transmitting power (P) by a factor of at least $43 + 10 \log(P)$ dB.

4.5.2 TEST PROCEDURES

All measurements were done at low and high operational frequency range.

The RF output of the transmitter was connected to the input of the spectrum analyzer through sufficient attenuation.

4.5.3 TEST SETUP LAYOUT

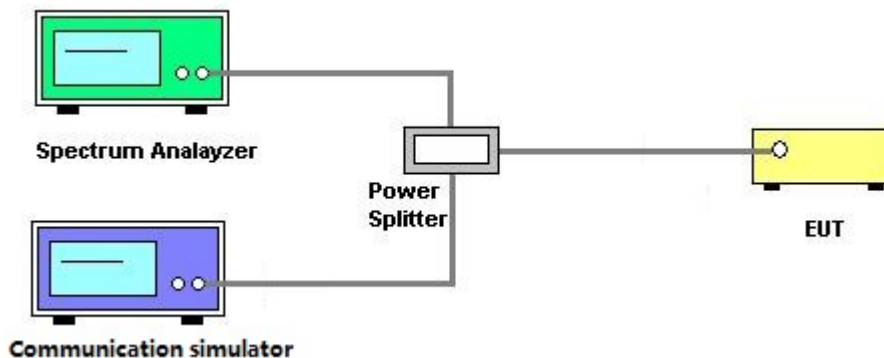

4.5.4 TEST DEVIATION

No deviation

4.5.5 TEST RESULTS

Please refer to the Appendix G.

4.6 PEAK TO AVERAGE RATIO MEASUREMENT

4.6.1 LIMIT

In measuring transmissions in this band using an average power technique, the peak to-average ratio (PAR) of the transmission may not exceed 13 dB.

4.6.2 TEST PROCEDURES

1. Set resolution/measurement bandwidth \geq signal's occupied bandwidth;
2. Set the number of counts to a value that stabilizes the measured CCDF curve;
3. Record the maximum PAPR level associated with a probability of 0.1%.

4.6.3 TEST SETUP LAYOUT

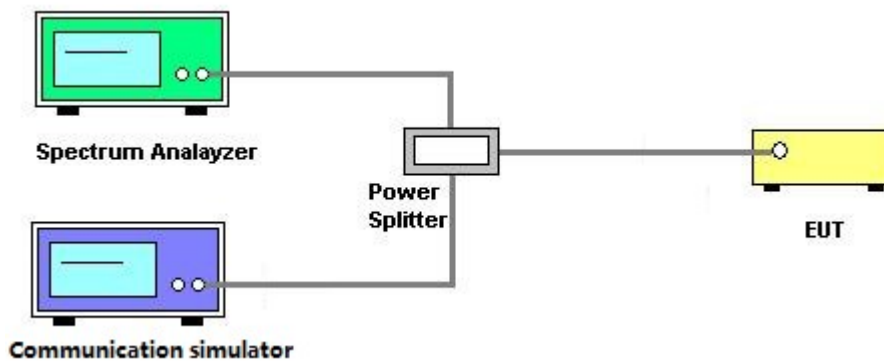

4.6.4 TEST DEVIATION

No deviation

4.6.5 TEST RESULTS

Please refer to the Appendix H.

4.7 FREQUENCY STABILITY MEASUREMENT

4.7.1 LIMIT

± 1.5 ppm is for base and fixed station. ± 2.5 ppm is for mobile station.

4.7.2 TEST PROCEDURES

1. Device is placed at the oven room. The oven room could control the temperatures and humidity. Power warm up is at least 15 min and power applied should perform before recording frequency error.
2. EUT is connected the external power supply to control the DC input power. The test voltage range is from minimum to maximum working voltage. Each step shall be record the frequency error rate.
3. The temperature range step is 10 degrees in this test items. All temperature levels shall be hold the $\pm 0.5^{\circ}\text{C}$ during the measurement testing. The each temperature step shall be at least 0.5 hours, consider the EUT could be test under the stability condition.
4. The frequency error was recorded frequency error from the communication simulator.

4.7.3 TEST SETUP LAYOUT

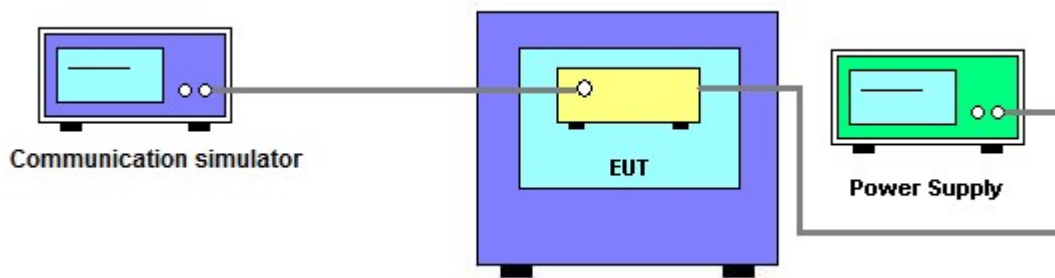

4.7.4 TEST DEVIATION

No deviation

4.7.5 TEST RESULTS

Please refer to the Appendix I.

5. LIST OF MEASUREMENT EQUIPMENTS

Radiated Emission Measurement(9kHz-30MHz)						
Item	Kind of Equipment	Manufacturer	Type No.	Serial No.	Calibrated date	Calibrated until
1	Loop Antenna	SCHWARZBECK	FMZB1519B	00029	2021/11/10	2022/11/09
2	EMI Test Receiver	Rohde&Schwarz	ESR7	102013	2021/11/10	2022/11/09
3	ECSI RF IN RF Cable	Rohde&Schwarz	AP-X1	\	2021/11/10	2022/11/09
4	Measurement Software	Farad	EZ-EMC Ver.TW-03A2	N/A	N/A	N/A
5	Wideband Radio Communication Tester	Rohde & Schwarz	CMW500	1201.0002K50-116064	2021/11/03	2022/11/02

Radiated Emission Measurement(30MHz-1GHz)						
Item	Kind of Equipment	Manufacturer	Type No.	Serial No.	Calibrated date	Calibrated until
1	Integral Antenna	Schwarzbeck	VULB 9163	VULB 9163-361	2021/11/10	2022/11/09
2	EMI Test Receiver	Rohde&Schwarz	ESR7	102013	2021/11/10	2022/11/09
3	Preamplifier	CD Systems Inc	PAP-03036-30	85060000	2021/11/10	2022/11/09
4	ECSI RF IN RF Cable	Rohde&Schwarz	AP-X1	\	2021/11/10	2022/11/09
5	Measurement Software	Farad	EZ-EMC Ver.TW-03A2	N/A	N/A	N/A
6	Wideband Radio Communication Tester	Rohde & Schwarz	CMW500	1201.0002K50-116064	2021/11/03	2022/11/02

Radiated Emission Measurement(Above 1GHz)						
Item	Kind of Equipment	Manufacturer	Type No.	Serial No.	Calibrated date	Calibrated until
1	Preamplifier	emci	EMC012645SE	980417	2021/11/10	2022/11/09
2	Preamplifier	Schwarzbeck	BBV9721	9721-019	2021/11/10	2022/11/09
3	Horn Antenna	Schwarzbeck	BBHA 9170	9170#685	2021/11/10	2022/11/09
4	Integral Antenna	Schwarzbeck	BBHA 9120D	BBHA 9120D 1201	2021/11/10	2022/11/09
5	Spectrum analyzer	Agilent	N9010A	MY52221119	2021/11/10	2022/11/09
6	Measurement Software	Farad	EZ-EMC Ver.TW-03A2	N/A	N/A	N/A
7	ECSI RF IN RF Cable	Rohde&Schwarz	AP-X1	\	2021/11/10	2022/11/09
8	Wideband Radio Communication Tester	Rohde & Schwarz	CMW500	1201.0002K50-116064	2021/11/03	2022/11/02

Conducted Emission & Band Edge & Occupied Bandwidth Measurement						
	Kind of Equipment	Manufacturer	Type No.	Serial No.	Calibrated date	Calibrated until
1	Wideband Radio Communication Tester	Rohde & Schwarz	CMW500	1201.0002K50-116064	2021/11/03	2022/11/02
2	Spectrum Analyzer	KEYSIGHT	N9020B	MY57463781	2021/11/10	2022/11/09

Frequency Stability Measurement						
	Kind of Equipment	Manufacturer	Type No.	Serial No.	Calibrated date	Calibrated until
1	Wideband Radio Communication Tester	Rohde & Schwarz	CMW500	1201.0002K50-116064	2021/11/03	2022/11/02
2	Spectrum Analyzer	KEYSIGHT	N9020B	MY57463781	2021/11/10	2022/11/09
3	Temp&Humidity Chamber	ETMOA	NTH1100-30A	16080628	2021/11/10	2022/11/09

Remark: "N/A" denotes no model name, serial no. or calibration specified.

APPENDIX A – RF OUTPUT POWER

TEST DATA:

GSM1900		Tune-up	Conducted Power (dBm)			EIRP (dBm)		
			Channel 512	Channel 661	Channel 810	Channel 512	Channel 661	Channel 810
			1850.2 (MHz)	1880 (MHz)	1909.8 (MHz)	1850.2 (MHz)	1880 (MHz)	1909.8 (MHz)
GSM (CS)		30±2dB	29.2	29.49	29.90	29.63	29.92	30.33
GPRS/EDGE (GMSK)	1 Tx Slot	30.00	29.74	29.90	30.05	30.17	30.33	30.48
	2 Tx Slot	29.00	28.5	28.70	28.86	28.93	29.13	29.29
	3 Tx Slot	28.00	27.29	27.45	27.61	27.72	27.88	28.04
	4 Tx Slot	27.00	25.91	26.30	26.69	26.34	26.73	27.12
EDGE (8PSK)	1 Tx Slot	26.00	25.32	25.95	25.77	25.75	26.38	26.20
	2 Tx Slot	24.00	24.13	24.74	24.52	24.56	25.17	24.95
	3 Tx Slot	22.00	23.23	23.53	23.37	23.66	23.96	23.80
	4 Tx Slot	21.00	22.37	22.18	22.46	22.80	22.61	22.89

APPENDIX B - OCCUPIED BANDWIDTH

TEST DATA:

PCS 1900 Band (Part 24E) GSM mode			
Channel	Frequency (MHz)	99% Occupied Bandwidth (kHz)	-26dB occupied bandwidth (kHz)
512	1850.2	243.14	312.10
661	1880.0	240.92	301.90
810	1909.8	239.86	306.70

PCS 1900 Band (Part 24E) EGPRS mode			
Channel	Frequency (MHz)	99% Occupied Bandwidth (kHz)	-26dB occupied bandwidth (kHz)
512	1850.2	240.01	305.30
661	1880.0	239.64	303.50
810	1909.8	240.52	303.70

TEST GRAPHS

PCS 1900-channel 512 (GSM mode)



PCS 1900-channel 661 (GSM mode)



PCS 1900-channel 810 (GSM mode)



PCS 1900-channel 512 (EGPRS mode)



PCS 1900-channel 661 (EGPRS mode)



PCS 1900-channel 810 (EGPRS mode)



APPENDIX C - CONDUCTED EMISSIONS

TEST DATA:

Band	Channel	Frequency Range	Frequency (MHz)	Result (dBm)	Limit (dBm)	Verdict
PCS1900 GSM mode	661	0.009~0.15MHz	0.009	-54.414	-43	PASS
PCS1900 GSM mode	661	0.15~30MHz	0.15	-33.616	-33	PASS
PCS1900 GSM mode	661	30~20000MHz	18342.0	-28.915	-13	PASS
PCS1900 EGPRS mode	661	0.009~0.15MHz	0.009	-53.930	-43	PASS
PCS1900 EGPRS mode	661	0.15~30MHz	0.15	-34.042	-33	PASS
PCS1900 EGPRS mode	661	30~20000MHz	17763.0	-30.173	-13	PASS

Note: We tested Low, Middle and High channels, Only the worst mode data is reflected in the report.

TEST GRAPHS

PCS1900 Channel 661-0.009~0.15MHz(GSM mode)

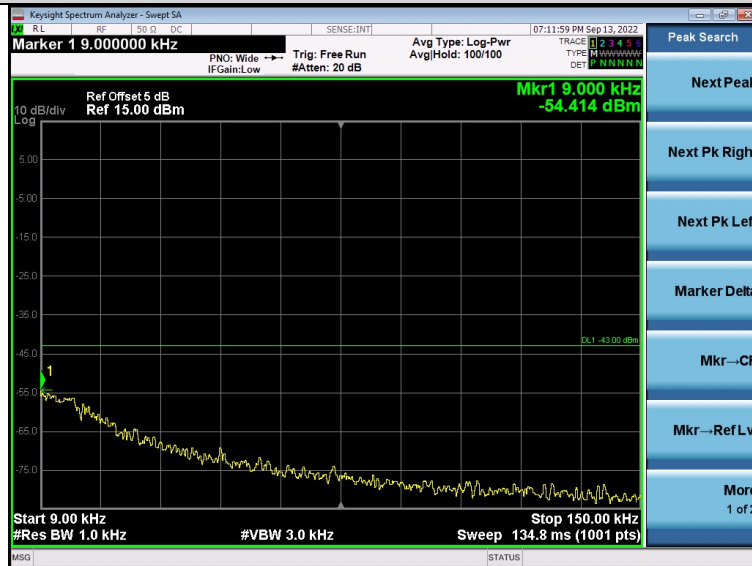

PCS1900 Channel 661-0.15~30MHz(GSM mode)

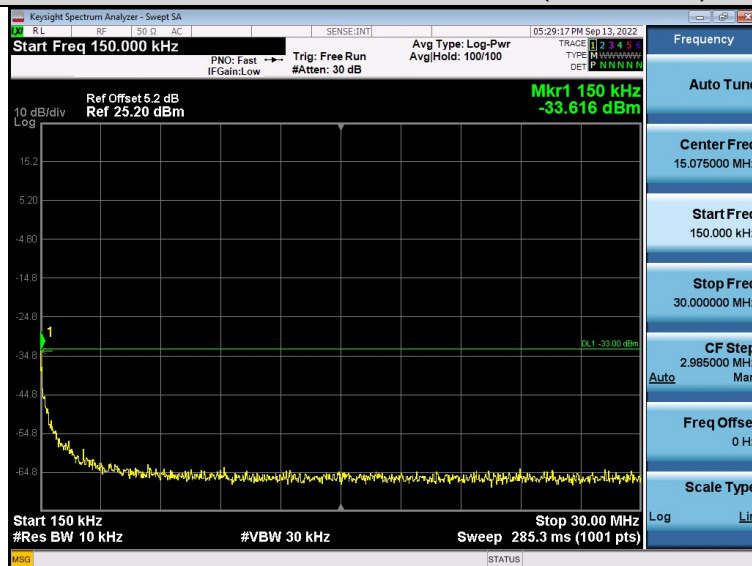

PCS1900 Channel 661-30~20000MHz(GSM mode)



PCS1900 Channel 661-0.009~0.15MHz(EGPRS mode)



PCS1900 Channel 661-0.15~30MHz(EGPRS mode)

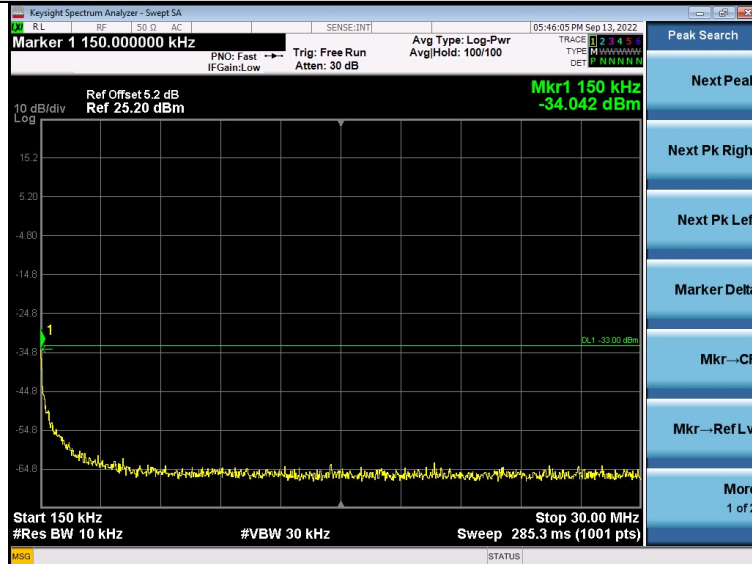

PCS1900 Channel 661-30~20000MHz(EGPRS mode)



APPENDIX D - RADIATED EMISSION (9KHz TO 30MHz)

Test Mode:	GSM1900 TX Mode
------------	-----------------

The amplitude of spurious emissions attenuated more than 20 dB below the permissible value is not required to be report.

APPENDIX E - RADIATED EMISSION(30MHZ-1GHZ)

Note:

1. Emissions attenuated more than 20 dB below the permissible value are not reported.
2. The EUT is tested radiation emission at each test mode in three axes. The worst emissions are reported in all test mode and channels.
3. Measurement = Reading + Correct Factor
Over = Measurement – Limit.
4. The EUT is tested radiation emission at each test mode (GSM mode, GPRS mode and EGPRS mode) in three axes. The worst case emission(the GSM mode) are reflected in the following form.

Test Mode:	GSM1900 TX Mode
------------	-----------------

Site: SH-CB02	Polarization: <i>Vertical</i>	Temperature: 24 (C)
Limit: FCC PART 24 EMISSION	Power: DC 3.8V	Humidity: 58 %
EUT: LTE module	Distance: 3m	
M/N: TOBY-L3414	Mode: TX_GSM1900	
Note:		

Radiated Emission Measurement

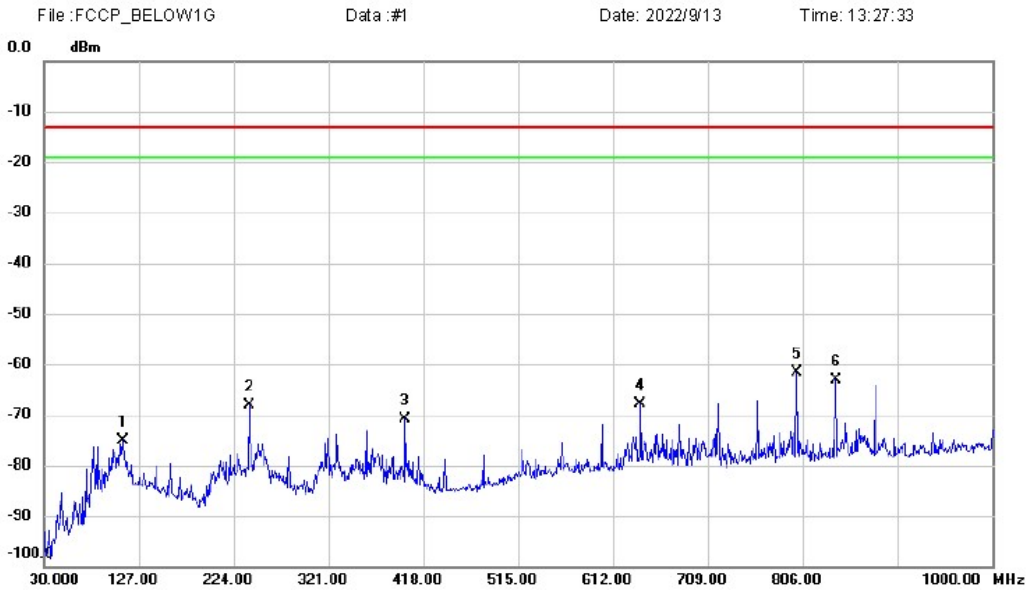

No.	Mk.	Freq.	Reading	Correct	Measure-	Limit	Margin	Detector	Comment
		MHz	Level	Factor	ment				
			dBm	dB	dBm	dBm	dB		
1		110.5100	-75.25	0.01	-75.24	-13.00	-62.24	RMS	
2		239.5200	-62.55	-5.49	-68.04	-13.00	-55.04	RMS	
3		399.5700	-69.34	-1.55	-70.89	-13.00	-57.89	RMS	
4		640.1300	-69.71	1.95	-67.76	-13.00	-54.76	RMS	
5	*	800.1800	-64.97	3.44	-61.53	-13.00	-48.53	RMS	
6		839.9500	-66.74	3.60	-63.14	-13.00	-50.14	RMS	

APPENDIX F - RADIATED EMISSION (ABOVE 1GHZ)

- Note: 1. Emissions attenuated more than 20 dB below the permissible value are not reported (For example:18-20GHz).
2. The EUT is tested radiation emission at each test mode in three axes. The worst emissions are reported in all test mode and channels.
3. Measurement = Reading + Correct Factor
 Over = Measurement – Limit.
4. The EUT is tested radiation emission at each test mode (GSM mode, GPRS mode and EGPRS mode) in three axes. The worst case emission(the GSM mode) are reflected in the following form.

Test Mode:	GSM1900 TX Mode
-------------------	-----------------

Site: SH-CB02	Polarization: <i>Horizontal</i>	Temperature: 24 (C)
Limit: FCC PART 24 EMISSION	Power: DC 3.8V	Humidity: 58 %
EUT: LTE module	Distance: 3m	
M/N: TOBY-L3414	Mode: TX_GSM1900	
Note:		

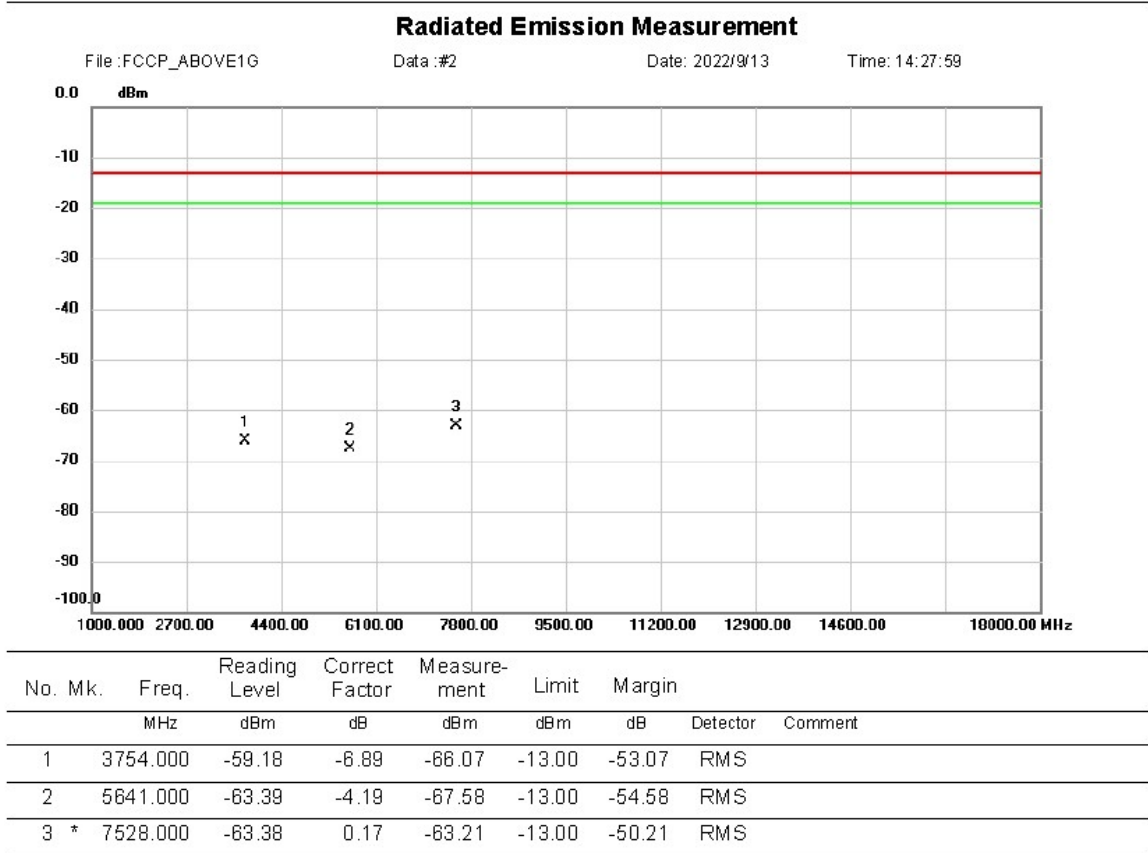

APPENDIX G - BAND EDGE

GSM mode
PCS Band (Part 24E)

Mode	Frequency (MHz)	Emission (dBm)	Limit (dBm)	Verdict
PCS1900	1850.000	-31.868	-13	PASS
	1910.000	-34.064	-13	PASS

EGPRS mode
PCS Band (Part 24E)

Mode	Frequency (MHz)	Emission (dBm)	Limit (dBm)	Verdict
PCS1900	1850.000	-31.474	-13	PASS
	1910.000	-32.088	-13	PASS

Note: The offset on the picture below = The loss of test cable+Splitter.

TEST GRAPHS

PCS1900 Low Channel (GSM mode)

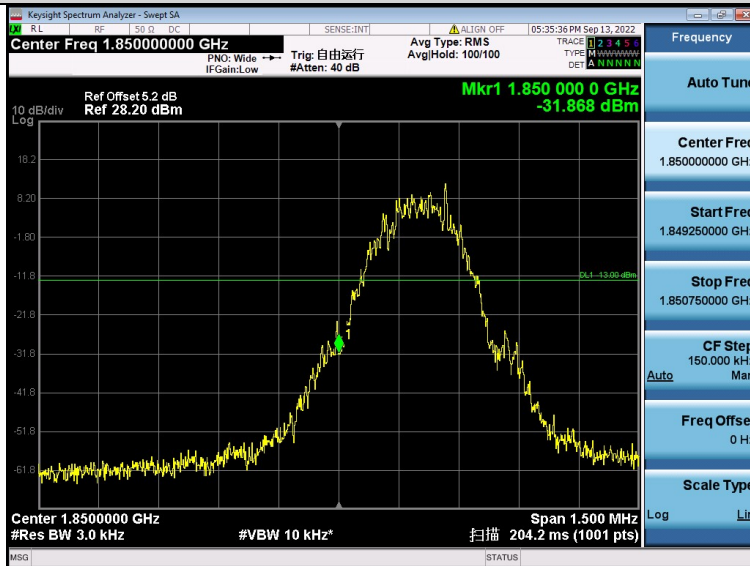

PCS1900 High Channel (GSM mode)

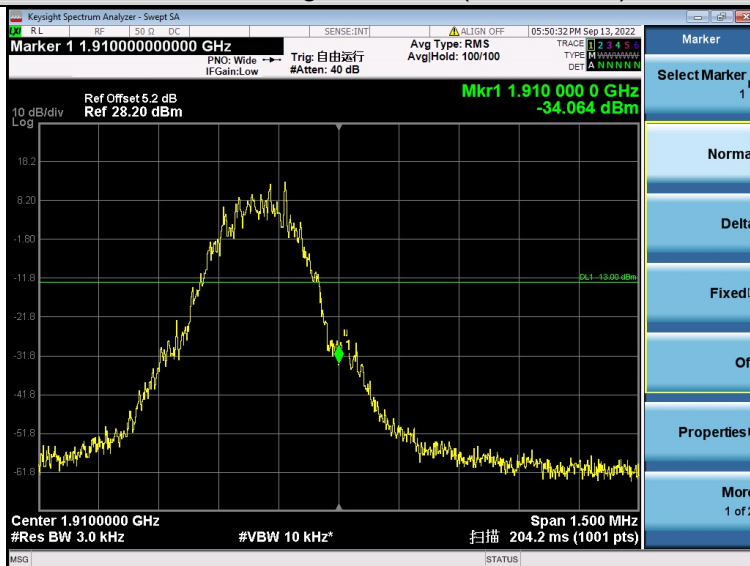

PCS1900 Low Channel (EGPRS mode)

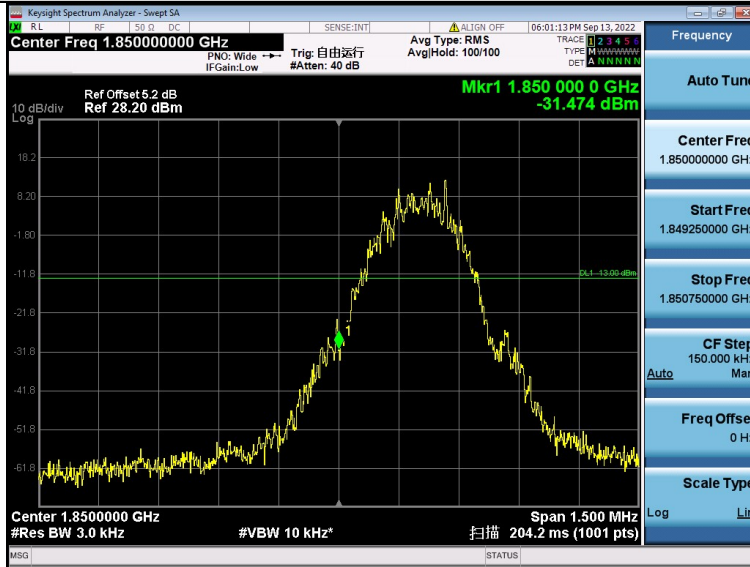

PCS1900 High Channel (EGPRS mode)

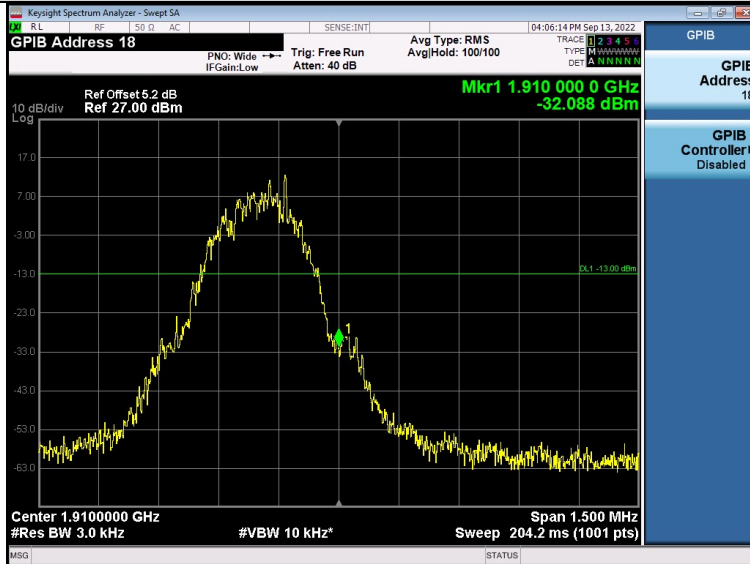

APPENDIX H - PEAK TO AVERAGE RATIO

Mode	CHANNEL	Frequency (MHz)	PEAK TO AVERAGE RATIO (dB)	Limit(dB)	Verdict
GSM1900	512	1850.2	2.92	13	PASS
GSM1900	661	1880.0	2.92	13	PASS
GSM1900	810	1909.8	2.92	13	PASS
EGPRS1900	512	1850.2	2.92	13	PASS
EGPRS1900	661	1880.0	2.92	13	PASS
EGPRS1900	810	1909.8	2.92	13	PASS

TEST GRAPHS

PCS1900-Channel 512(GSM mode)

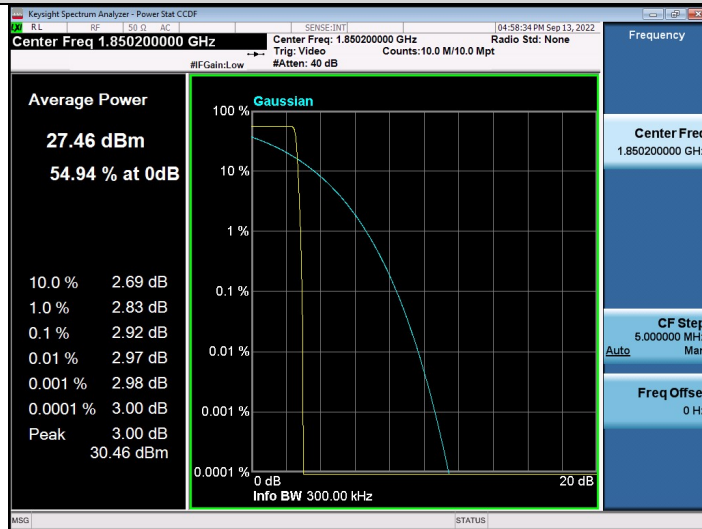

PCS1900-Channel 661(GSM mode)

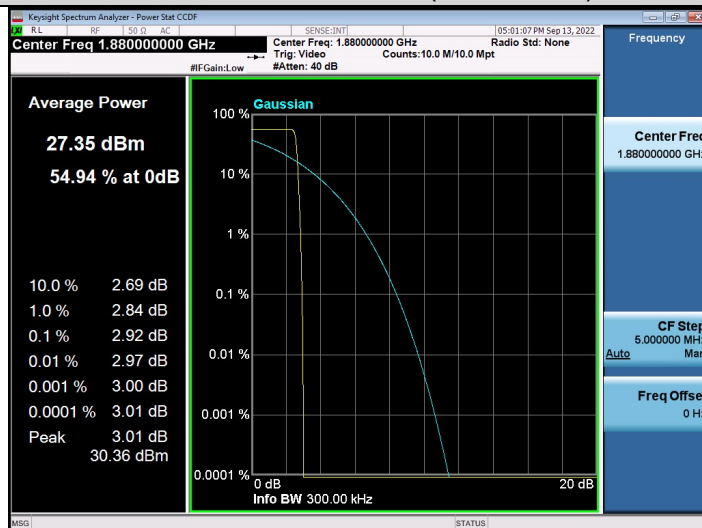

PCS1900-Channel 810(GSM mode)

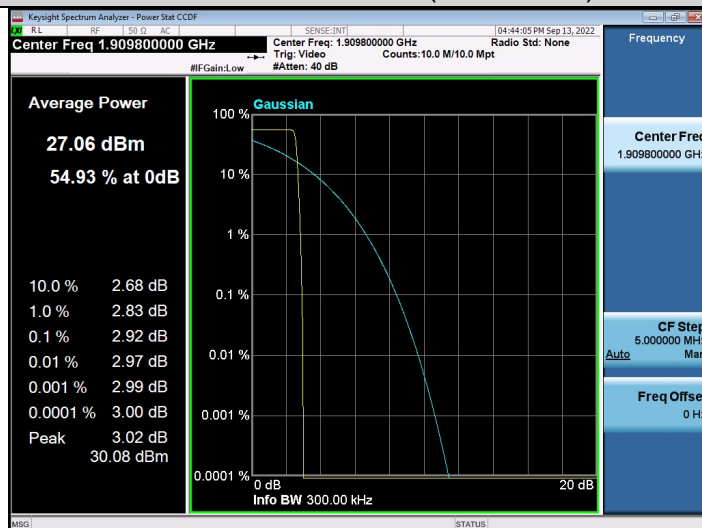

PCS1900-Channel 512(EGPRS mode)

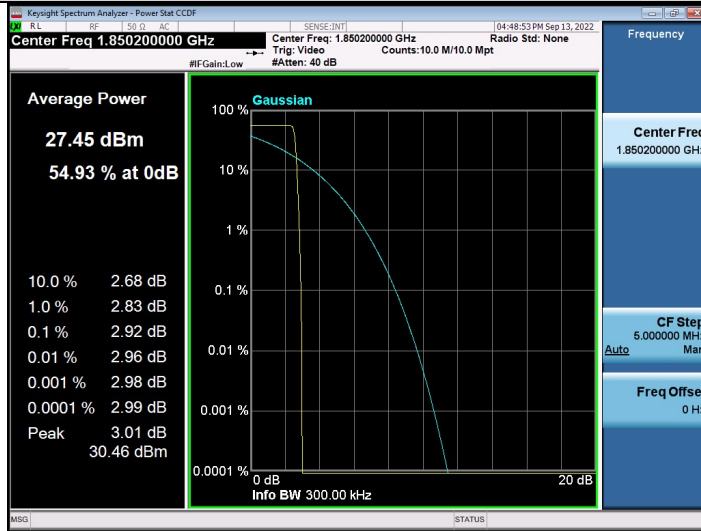

PCS1900-Channel 661(EGPRS mode)

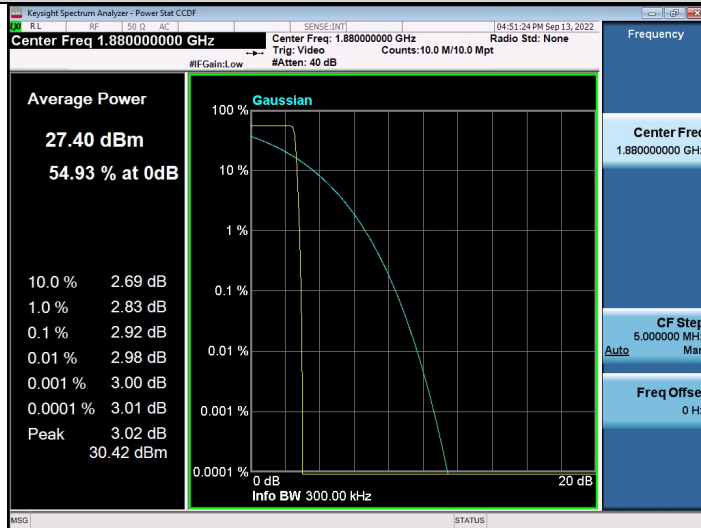

PCS1900-Channel 810(EGPRS mode)

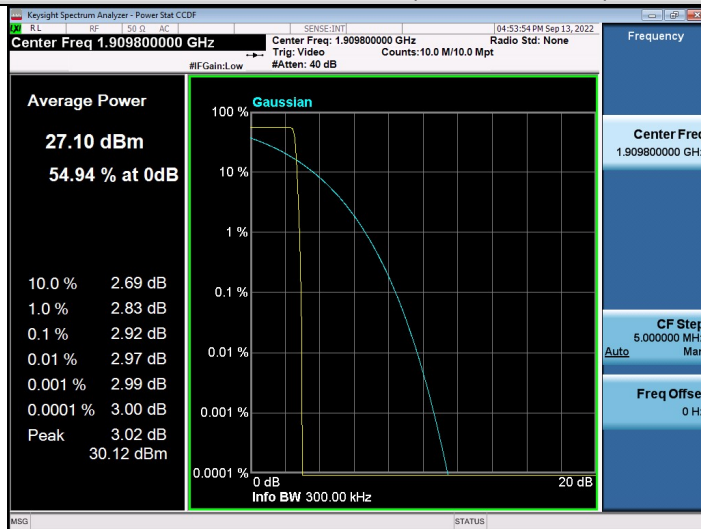

APPENDIX I - FREQUENCY STABILITY

PCS 1900				
Channel:	661	Frequency:	1880MHz	
Temperature vs. Frequency Stability				
Temperature(°C)	Frequency Error (Hz)	Frequency Error (ppm)	Limit (ppm)	
-40	4.32	0.002297872	±2.5	
-30	4.321	0.002298404		
-20	5.69	0.003026596		
-10	4.22	0.002244681		
0	-3.15	-0.001675532		
10	-3.18	-0.001691489		
20	-5.22	-0.002776596		
30	-3.11	-0.001654255		
40	2.66	0.001414894		
50	1.95	0.001037234		
60	2.36	0.001255319		
70	4.66	0.002478723		
85	6.25	0.003324468		
Max. Deviation (ppm)	6.25	0.002478723		

PCS 1900			
Channel:	661	Frequency:	1880MHz
Voltage vs. Frequency Stability			
Voltage(Volts)	Frequency Error (Hz)	Frequency Error (ppm)	Limit (ppm)
4.2	-5.22	-0.002776596	±2.5
3.8	-9.19	-0.004888298	
3.3	-7.32	-0.003893617	
Max. Deviation (ppm)	9.19	-0.002776596	

Note: We tested Low, Middle and High channels, Only the worst mode data is reflected in the report.

End of Test Report