

RF MEASUREMENT REPORT

FCC ID: 2A3Y3-NSM01
Applicant: Honeywell Safety Products USA, Inc.
Product: Smart Main Module
Model No.: NSM-01
Brand Name: Honeywell and/or NORTH
FCC Classification: Ultra Wideband Transmitter
FCC Rule Part(s): Part 15 Subpart F (Section 15.519)
Test Date: December 03, 2021 ~ March 07, 2022

Reviewed By:

Jame Yuan

Approved By:

Robin Wu



The test results relate only to the samples tested.

This equipment has been shown to be capable of compliance with the applicable technical standards as indicated in the measurement report and was tested in accordance with the measurement procedures specified in ANSI C63.10-2013. Test results reported herein relate only to the item(s) tested.

The test report shall not be reproduced except in full without the written approval of MRT Technology (Suzhou) Co., Ltd.

Revision History

Report No.	Version	Description	Issue Date	Note
2111RSU020-U1	Rev. 01	Initial Report	03-07-2022	Valid

CONTENTS

Description	Page
1. General Information	5
1.1. Applicant	5
1.2. Manufacturer	5
1.3. Testing Facility	5
1.4. Product Information.....	6
1.5. Radio Specification	6
2. Test Configuration	7
2.1. Test System Connection Diagram.....	7
2.2. Applied Standards.....	7
2.3. Test Environment Condition	7
2. Antenna Requirement	8
3. Measuring Instrument	9
4. Measurement Uncertainty.....	10
5. Test Result.....	11
5.1. Summary.....	11
5.2. Operating Bandwidth	12
5.2.1. Test Limit	12
5.2.2. Test Procedure used	12
5.2.3. Test Setting	12
5.2.4. Test Setup	13
5.2.5. Test Result	13
5.3. Peak Power within 50 MHz bandwidth and Maximum Average Emissions	14
5.3.1. Test Limit	14
5.3.2. Test Procedure Used	14
5.3.3. Test Setting	14
5.3.4. Test Setup	15
5.3.5. Test Result	15
5.4. Cessation Time	16
5.4.1. Test Limit	16
5.4.2. Test Procedure Used	16
5.4.3. Test Setting	16
5.4.4. Test Setup	16
5.4.5. Test Result	16
5.5. Radiated Spurious Emission.....	17
5.5.1. Test Limit	17

5.5.2.	Test Procedure Used	17
5.5.3.	Test Setting	18
5.5.4.	Test Setup	18
5.5.5.	Test Result	19
5.6.	AC Conducted Emissions	20
5.6.1.	Test Limit	20
5.6.2.	Test Setup	20
5.6.3.	Test Result	20
Appendix A – Test Result		21
A.1	Operating Bandwidth Test Result.....	21
A.2	Peak Power and Maximum Average Emissions Test Result	22
A.3	Cessation Time Test Result	23
A.4	Radiated Spurious Emission Test Result.....	24
A.5	AC Conducted Emissions Test Result	27
Appendix B - Test Setup Photograph		29
Appendix C - EUT Photograph		30

1.4. Product Information

Product Name	Smart Main Module
Model No.	NSM-01
EUT Identification No.	20211105Sample#03
Hardware Version	V1.3
Software Version	V1.0
UWB Specification	3993.6MHz, Single Channel
Bluetooth Specification	v5.1, Single mode
Power Supply	DC 5V,1A
Remark: The information of EUT was provided by the manufacturer, and the accuracy of the information shall be the responsibility of the manufacturer.	

1.5. Radio Specification

Operation Frequency	3993.6MHz
Channel Number	1
Type of modulation	BPM-BPSK

Note: For other features of this EUT, test report will be issued separately.

2. Test Configuration Test System Connection Diagram

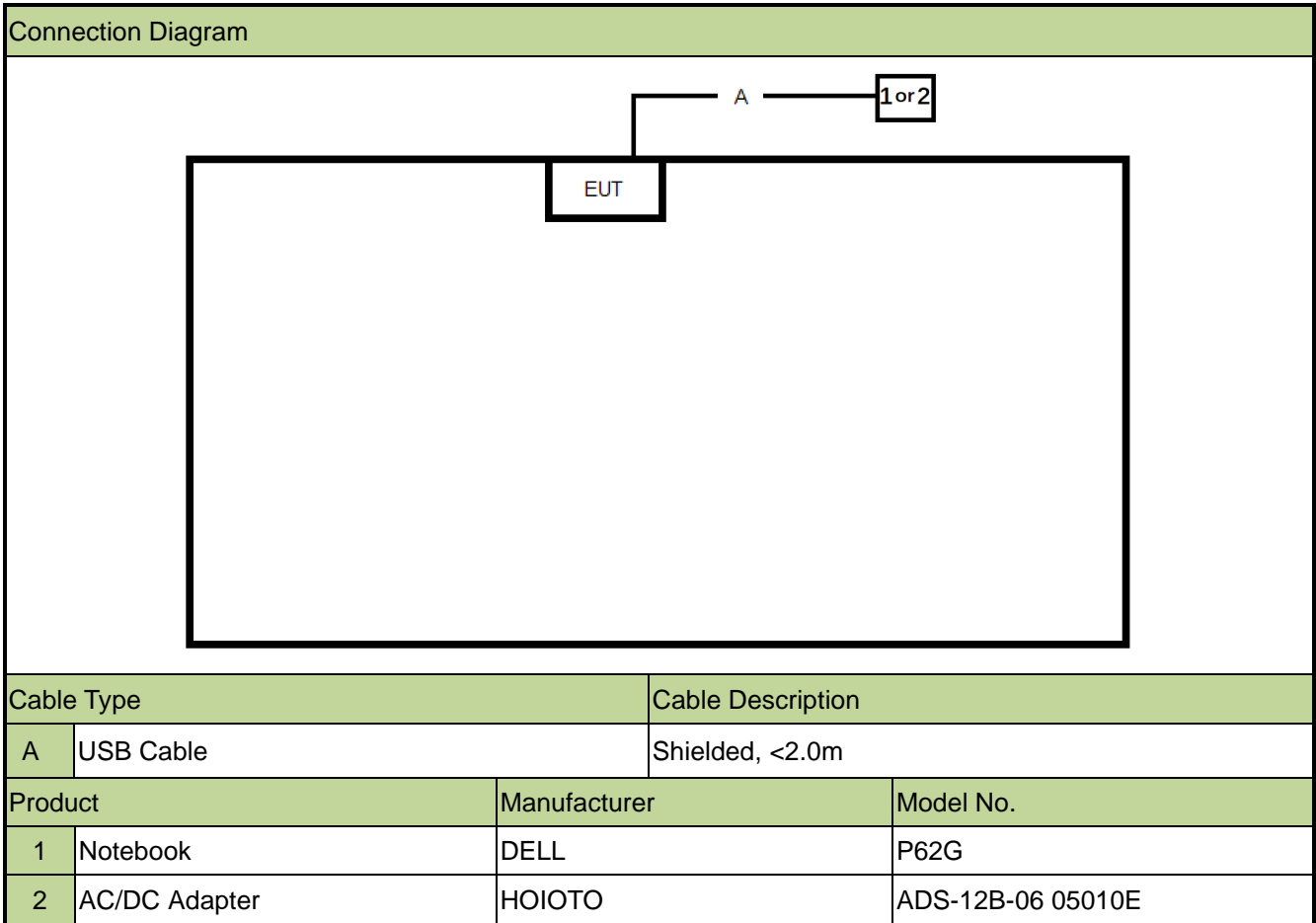

2.2. Applied Standards

According to the specifications of the manufacturer, the EUT must comply with the requirements of the following standards:

- FCC Part 15.519
- KDB 393764 D01 UWB FAQ v02
- ANSI C63.10-2013

2.3. Test Environment Condition

Ambient Temperature	15 ~ 35°C
Relative Humidity	20 ~ 75%RH

2. Antenna Requirement

Excerpt from §15.203 of the FCC Rules/Regulations:

“An intentional radiator antenna shall be designed to ensure that no antenna other than that furnished by the responsible party can be used with the device. The use of a permanently attached antenna or of an antenna that uses a unique coupling to the intentional radiator shall be considered sufficient to comply with the provisions of this section.”

- The antenna of the EUT is **permanently attached**.
- There are no provisions for connection to an external antenna.

Conclusion:

The unit complies with the requirement of §15.203.

3. Measuring Instrument

No.	Instrument	Manufacturer	Model No.	Asset No.	Last Cali. Date	Cali. Due Date	Test Site
1	Loop Antenna	Schwarzbeck	FMZB 1519	MRTSUE06025	1 year	2022/10/28	WZ-AC1/WZ-AC2
2	Horn Antenna	ETS	3117	MRTSUE06257	1 year	2022/9/25	WZ-AC1/WZ-AC2
3	Horn Antenna	Schwarzbeck	BBHA 9170	MRTSUE06597	1 year	2022/12/1	WZ-AC1/WZ-AC2
4	TRILOG Antenna	Schwarzbeck	VULB 9162	MRTSUE06022	1 year	2022/5/24	WZ-AC2
5	EMI Test Receiver	Agilent	N9038A	MRTSUE06125	1 year	2022/6/24	WZ-AC2
6	Thermohygrometer	Mingle	ETH529	MRTSUE06170	1 year	2022/12/1	WZ-AC2
7	Horn Antenna	Schwarzbeck	BBHA 9120D	MRTSUE06171	1 year	2022/10/21	WZ-AC2
8	Preamplifier	Schwarzbeck	BBV 9718	MRTSUE06176	1 year	2022/11/12	WZ-AC2
9	Anechoic Chamber	RIKEN	WZ-AC2	MRTSUE06213	1 year	2022/4/29	WZ-AC2
10	Thermohygrometer	testo	Testo 608-H1	MRTSUE11038	1 year	2022/11/11	WZ-AC2
11	Signal Analyzer	Agilent	N9040B	US60080142	1 year	2022/03/14	WZ-AC2
12	Two-Line V-Network	R&S	ENV216	MRTSUE06002	1 year	2022/6/8	WZ-SR2
13	Shielding Room	MIX-BEP	WZ-SR2	MRTSUE06215	/	/	WZ-SR2
14	Thermohygrometer	testo	608-H1	MRTSUE06404	1 year	2022/6/28	WZ-SR2
15	Four-Line V-Network	R&S	ENV432	MRTSUE06615	1 year	2022/10/10	WZ-SR2
16	EMI Test Receiver	R&S	ESR3	MRTSUE06909	1 year	2022/11/1	WZ-SR2
17	USB Power Sensor	Agilent	U2021XA	MRTSUE06030	1 year	2022/10/10	WZ-SR3/WZ-SR5
18	Signal Analyzer	Agilent	N9020A	MRTSUE06106	1 year	2022/4/13	WZ-SR5
19	Thermohygrometer	testo	608-H1	MRTSUE06402	1 year	2022/6/28	WZ-SR5
20	Shielding Room	HUAMING	WZ-SR5	MRTSUE06442	/	/	WZ-SR5
21	Signal Analyzer	Keysight	N9010B	MRTSUE06457	1 year	2022/6/24	WZ-SR5
22	Attenuator	SHX	6dB	MRTSUE06592	1 year	2022/5/24	WZ-SR5
23	Attenuator	SHX	WDTS100-20dB-6G-B	MRTSUE06680	1 year	2022/9/15	WZ-SR5

Software	Version	Function
EMI Software	V3	EMI Test Software

4. Measurement Uncertainty

Where relevant, the following test uncertainty levels have been estimated for tests performed on the EUT as specified in CISPR 16-4-2. This uncertainty represents an expanded uncertainty expressed at approximately the 95% confidence level using a coverage factor of $k = 2$.

Conducted Emission Measurement
Measurement Uncertainty for a Level of Confidence of 95% ($U=2Uc(y)$): 9kHz~150kHz: 3.74dB 150kHz~30MHz: 3.44dB
Radiated Disturbance
Measurement Uncertainty for a Level of Confidence of 95% ($U=2Uc(y)$): Horizontal: 9KHz~300MHz: 5.04dB 300MHz~1GHz: 4.95dB 1GHz~6GHz: 6.40dB Vertical: 9KHz~300MHz: 5.24dB 300MHz~1GHz: 6.03dB 1GHz~40GHz: 6.40dB
Spurious Emissions, Conducted
Measuring Uncertainty for a Level of Confidence of 95% ($U=2Uc(y)$): 0.78dB
Output Power
Measuring Uncertainty for a Level of Confidence of 95% ($U=2Uc(y)$): 1.13dB
Power Spectrum Density
Measuring Uncertainty for a Level of Confidence of 95% ($U=2Uc(y)$): 1.15dB
Occupied Bandwidth
Measuring Uncertainty for a Level of Confidence of 95% ($U=2Uc(y)$): 0.28%

5. Test Result

5.1. Summary

FCC Section(s)	Test Description	Test Condition	Test Result
§15.519(b)	Occupied Bandwidth	Radiated	Pass
§15.519(c)	Maximum Average Emissions		Pass
§15.519(c)	Peak Power within 50 MHz Bandwidth		Pass
§15.519(a)(1)	Transmission duration requirements		Pass
§15.519(c)	Radiated Spurious Emissions below 960 MHz		Pass
§15.519(c), (d)	Radiated Spurious Emissions above 960 MHz		Pass
15.207	AC Conducted Emissions 150kHz - 30MHz	Line Conducted	Pass

Notes:

1. The analyzer plots shown in this section were all taken with a correction table loaded into the analyzer. The correction table was used to account for the losses of the cables and attenuators used as part of the system to connect the EUT to the analyzer at all frequencies of interest.
2. All modes of operation and data rates were investigated. For radiated emission test, every axis (X, Y, Z) was also verified and showed the worst axis in the test setup photos. The test results shown in the following sections represent the worst case emissions.

5.2. Operating Bandwidth

5.2.1. Test Limit

§15.503 (a) UWB bandwidth. For the purpose of this subpart, the UWB bandwidth is the frequency band bounded by the points that are 10 dB below the highest radiated emission, as based on the complete transmission system including the antenna. The upper boundary is designated f_H and the lower boundary is designated f_L . The frequency at which the highest radiated emission occurs is designated f_M .

§15.503 (b) Center frequency. The center frequency, f_C , equals $(f_H + f_L)/2$.

§15.503 (c) Fractional bandwidth. The fractional bandwidth equals $2(f_H - f_L) / (f_H + f_L)$.

§15.503 (d) Ultra-wideband (UWB) transmitter. An intentional radiator that, at any point in time, has a fractional bandwidth equal to or greater than 0.20 or has a UWB bandwidth equal to or greater than 500 MHz, regardless of the fractional bandwidth.

§15.519 (b) The UWB bandwidth of a device operating under the provisions of this section must be contained between 3100 MHz and 10,600 MHz.

5.2.2. Test Procedure used

ANSI C63.10 – 2013 – Section 10.1

5.2.3. Test Setting

The frequency at which the maximum power level is measured with the peak detector is designated f_M . The peak power measurements shall be made using a spectrum analyzer or EMI receiver with a 1 MHz resolution bandwidth and a video bandwidth of 1 MHz or greater. The instrument shall be set to peak detection using the maximum-hold trace mode. The outermost 1 MHz segments above and below f_M , where the peak power falls by 10 dB relative to the level at f_M , are designated as f_H and f_L , respectively:

- a) For the lowest frequency bound f_L , the emission is searched from a frequency lower than f_M that has, by inspection, a peak power much lower than 10 dB less than the power at f_M and increased toward f_M until the peak power indicates 10 dB less than the power at f_M . The frequency of that segment is recorded.
- b) This process is repeated for the highest frequency bound f_H , beginning at a frequency higher than f_M that has, by inspection, a peak power much lower than 10 dB below the power at f_M . The frequency of that

segment is recorded.

c) The two recorded frequencies represent the highest f_H and lowest f_L bounds of the UWB transmission, and the -10 dB bandwidth ($B - 10$) is defined as $(f_H - f_L)$. The center frequency (f_c) is mathematically determined from $(f_H + f_L) / 2$.

d) The fractional bandwidth is defined as $2(f_H - f_L) / (f_H + f_L)$.

e) Determine whether the -10 dB bandwidth ($f_H - f_L$) is ≥ 500 MHz, or whether the fractional bandwidth $2(f_H - f_L) / (f_H + f_L)$ is ≥ 0.2 .

5.2.4. Test Setup

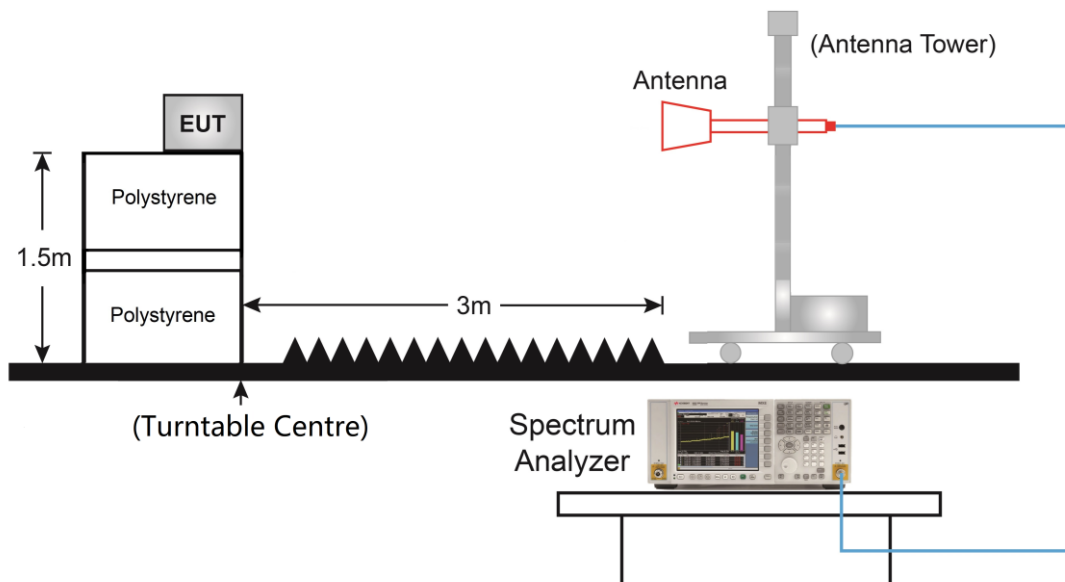

5.2.5. Test Result

Refer to Appendix A.1.

5.3. Peak Power within 50 MHz bandwidth and Maximum Average Emissions

5.3.1. Test Limit

§15.519 (c) There is a limit on the peak level of the emissions contained within a 50 MHz bandwidth centered on the frequency at which the highest radiated emission occurs, f_M . That limit is 0 dBm EIRP.

§15.519 (c) The radiated emissions above 960 MHz from a device operating under the provisions of this section shall not exceed the following average limits when measured using a resolution bandwidth of 1 MHz:

Assigned frequency band (MHz)	EIRP in dBm
3100 – 10600	-41.3

5.3.2. Test Procedure Used

ANSI C63.10 – 2013 – Section 10.3

5.3.3. Test Setting

The radiated emission of 6~9GHz frequency band are performed at 3 meters test distance.

Peak Power within 50 MHz bandwidth

Peak EIRP power is measured using RBW of 50MHz.

The peak detector of the instrument is selected and the maximum hold feature activated.

Maximum Average Emissions

The following procedure shall be used for evaluating rms-average power spectral density:

- a) Set the RBW to 1 MHz
- b) Set the VBW to 3 MHz
- c) Set the frequency span to examine the spectrum across a convenient frequency segment
- d) Select the power averaging (rms) detector
- e) Set the sweep time so that there is no more than a 1 ms integration period over each measurement bin

5.3.4. Test Setup

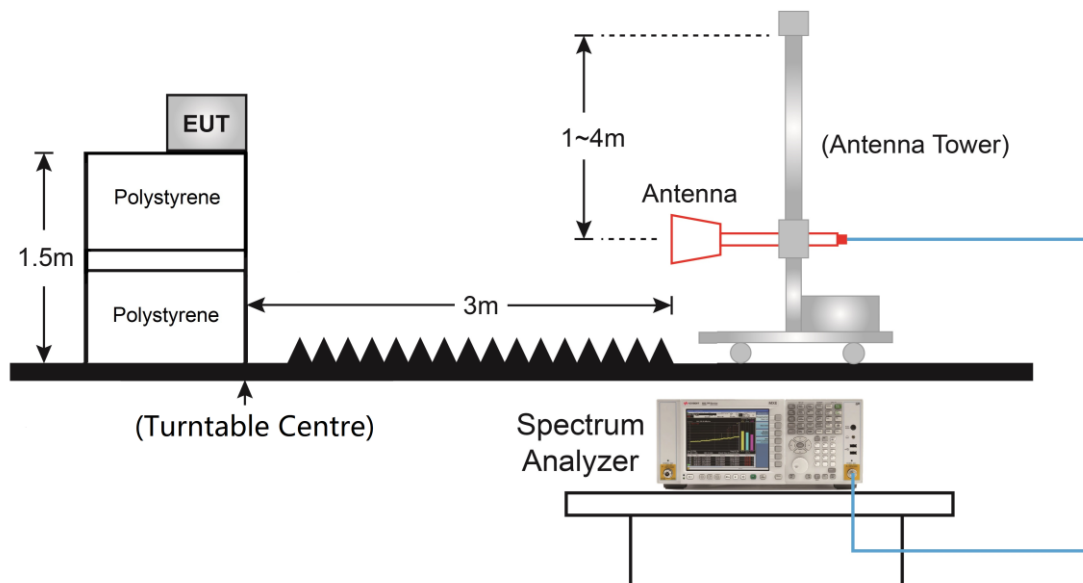

5.3.5. Test Result

Refer to Appendix A.2.

5.4. Cessation Time

5.4.1. Test Limit

§15.519 (a)(1) A UWB device operating under the provisions of this section shall transmit only when it is sending information to an associated receiver. The UWB intentional radiator shall cease transmission within 10 seconds unless it receives an acknowledgement from the associated receiver that its transmission is being received. An acknowledgment of reception must continue to be received by the UWB intentional radiator at least every 10 seconds or the UWB device must cease transmitting.

5.4.2. Test Procedure Used

Transmission is monitored when the EUT initiates the UWB link with the accessory.

5.4.3. Test Setting

1. Set instrument center frequency to UWB channel center frequency.
2. RBW = 1MHz.
3. VBW = 3MHz.
4. Detector = Peak.
5. Sweep time = auto couple.

5.4.4. Test Setup

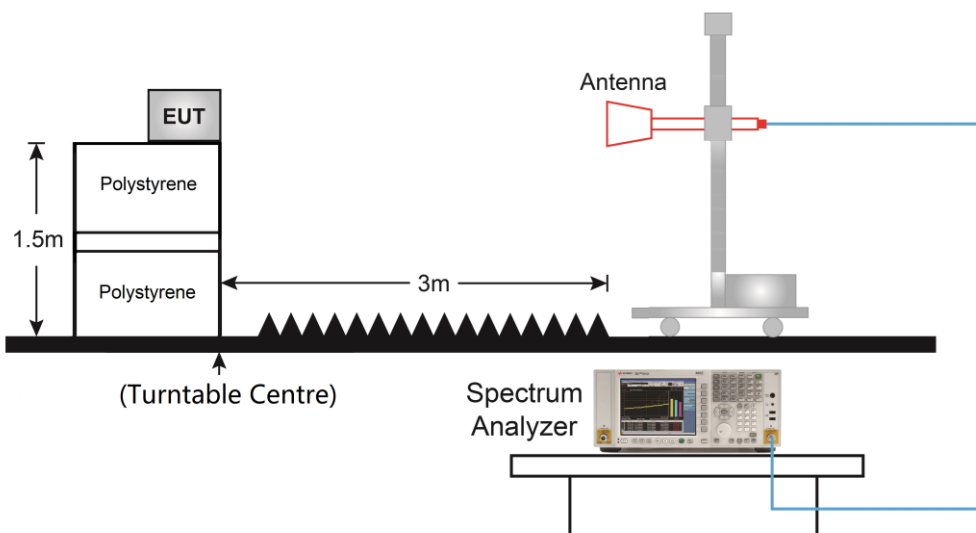

5.4.5. Test Result

Refer to Appendix A.3.

5.5. Radiated Spurious Emission

5.5.1. Test Limit

§15.519 (c) The radiated emissions at or below 960 MHz from a device operating under the provisions of this section shall not exceed the emission levels in § 15.209.

FCC Part 15 Subpart C Paragraph 15.209		
Frequency [MHz]	Field Strength [uV/m]	Measured Distance [Meters]
0.009 – 0.490	2400/F (kHz)	300
0.490 – 1.705	24000/F (kHz)	30
1.705 – 30	30	30
30 – 88	100	3
88 – 216	150	3
216 – 960	200	3
Above 960	500	3

§15.519 (c) The radiated emissions above 960 MHz from a device operating under the provisions of this section shall not exceed the following average limits when measured using a resolution bandwidth of 1 MHz:

Frequency [MHz]	RBW [kHz]	EIRP of spurious [dBm]
960 – 1610	1000	-75.3
1610 – 1990	1000	-63.3
1990 – 3100	1000	-61.3
3100 – 10600	1000	-41.3
Above 10600	1000	-61.3

§15.519 (d) In addition to the radiated emission limits specified in the table in paragraph (c) of this section, UWB transmitters operating under the provisions of this section shall not exceed the following average limits when measured using a resolution bandwidth of no less than 1 kHz:

Frequency [MHz]	RBW [kHz]	EIRP of spurious [dBm]
1164 – 1240	≥ 1	-85.3
1559 – 1610	≥ 1	-85.3

5.5.2. Test Procedure Used

ANSI C63.10 – 2013 – Section 10.2 & 10.3

5.5.3. Test Setting

Another test required for these types of devices involves the measurement of the maximum of the average power contained in any spectral lines present within the 1164 MHz to 1240 MHz and 1559 MHz to 1610 MHz frequency ranges. The measurement setup is similar to that described in 10.3.7 of ANSI C63.10. The rms detector is selected, and the sweep time and number of measurement bins are set to provide the requisite 1 ms integration time. In this test, the RBW may be reduced to a minimum of 1 kHz (30 kHz is recommended) to enhance the resolution of the individual spectral lines. A ratio of $VBW / RBW > 3$ shall be maintained when possible.

5.5.4. Test Setup

Below 30MHz Test Setup

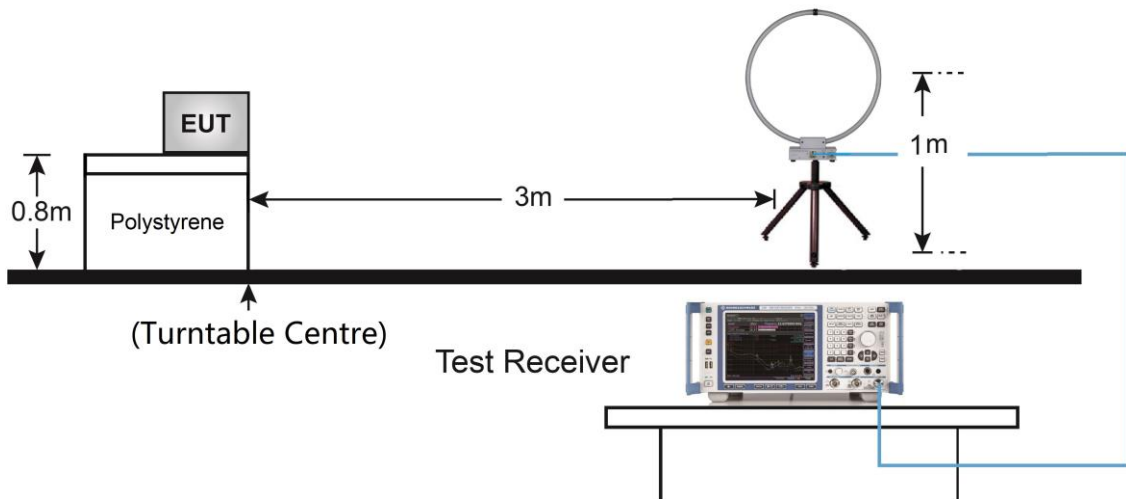

Above 30MHz Test Setup:

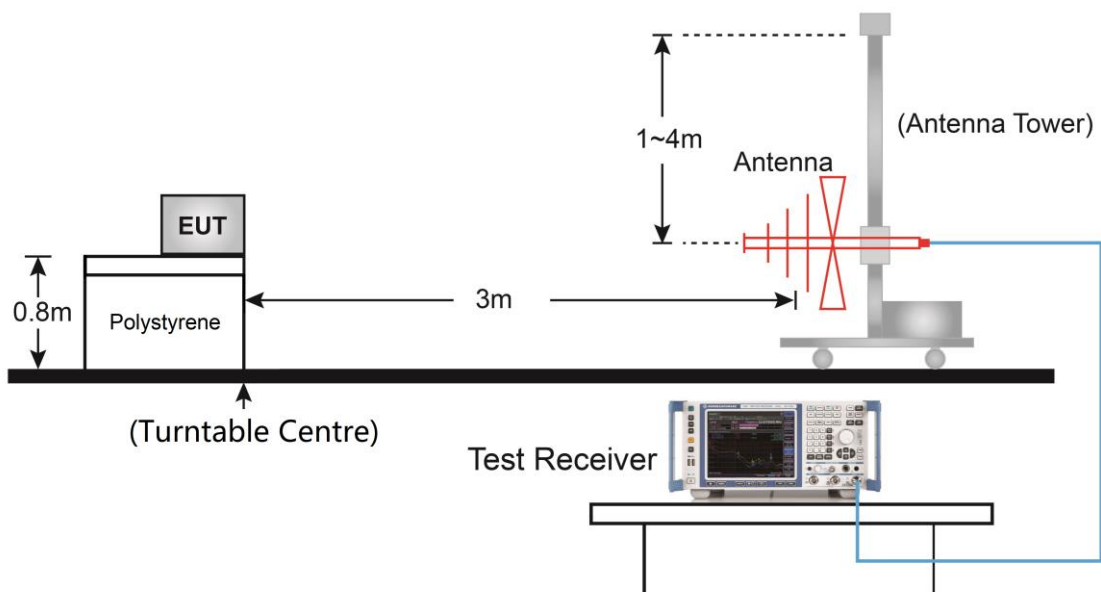

Above 1GHz Test Setup:

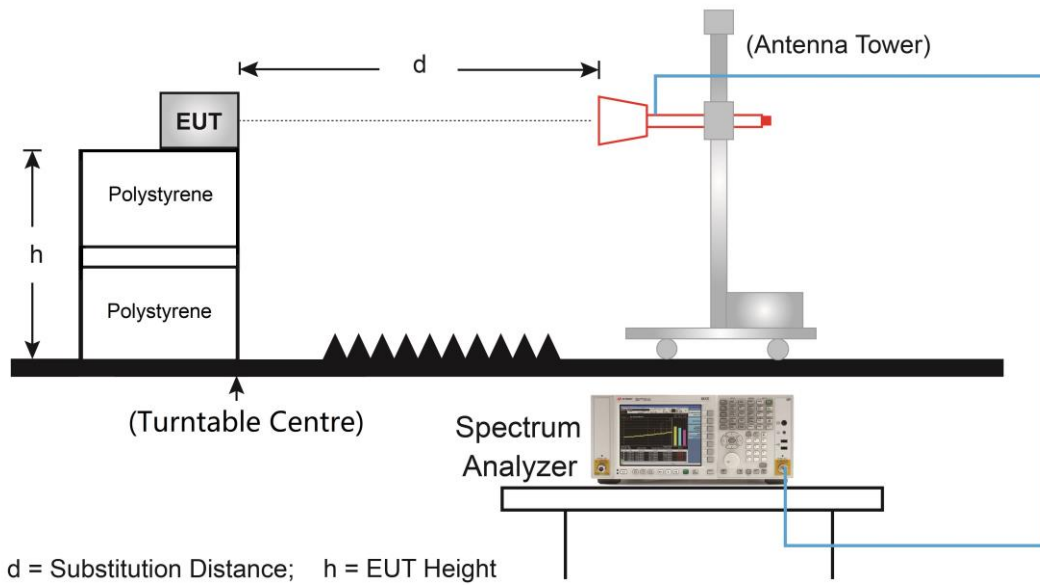

5.5.5. Test Result

Refer to Appendix A.4.

5.6. AC Conducted Emissions

5.6.1. Test Limit

RSS-GEN Issue 5 Section 8.8 Limits		
Frequency (MHz)	QP (dBuV)	AV (dBuV)
0.15 - 0.50	66 - 56	56 - 46
0.50 - 5.0	56	46
5.0 - 30	60	50

Note 1: The lower limit shall apply at the transition frequencies.

Note 2: The limit decreases linearly with the logarithm of the frequency in the range 0.15MHz to 0.5MHz.

5.6.2. Test Setup

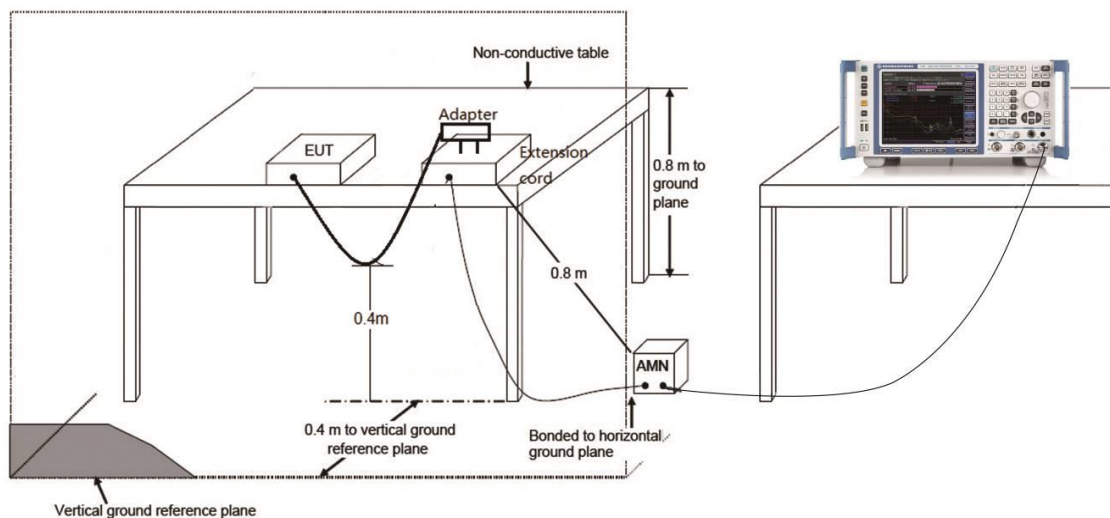

5.6.3. Test Result

Refer to Appendix A.5.

Appendix A – Test Result

A.1 Operating Bandwidth Test Result

Test Site	WZ-AC2	Test Engineer	Tommy Tang
Test Date	2022/1/11		

Frequency (MHz)	F _L (MHz)	Limit (MHz)	F _H (MHz)	Limit (MHz)	Result
3993.6	3706	> 3100	4344	< 10600	Pass

Frequency (MHz)	10dB Bandwidth (MHz)	Limit (MHz)	Result	F _C (MHz)
3993.6	638	≥ 500	Pass	4025

Note 1: 10dB Bandwidth = F_H - F_L = 4344 – 3706 = 638 MHz

Note 2: F_C = (F_H + F_L) / 2 = 4025 MHz

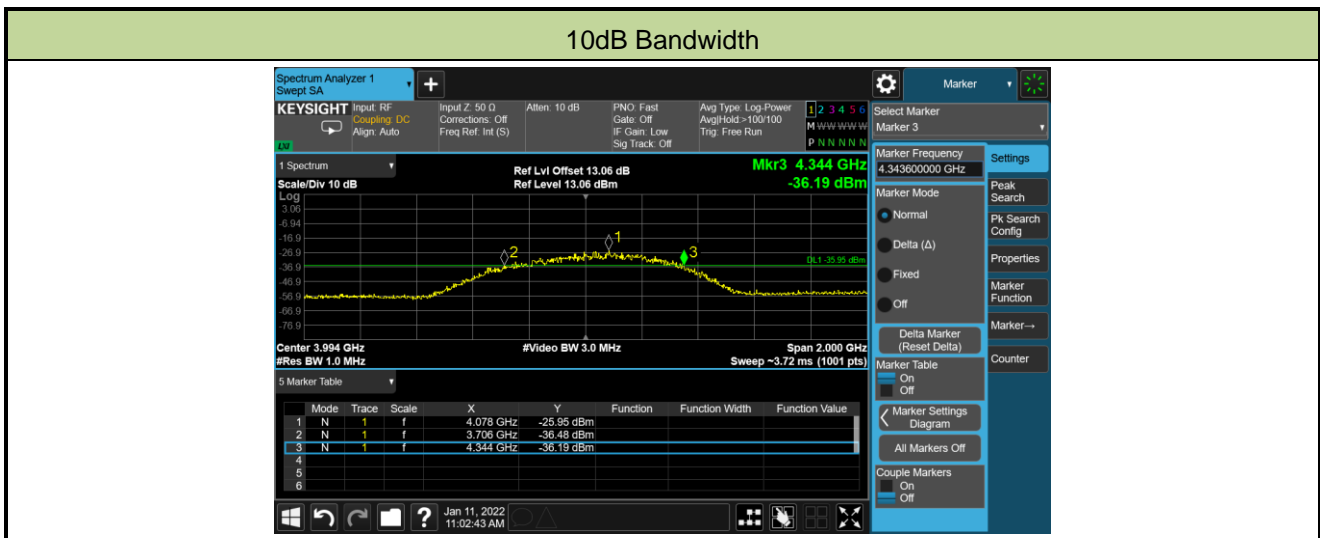

A.2 Peak Power and Maximum Average Emissions Test Result

Test Site	WZ-AC2	Test Engineer	Tommy Tang
Test Date	2021/12/03		

Test Result of Peak Output Power

Frequency (MHz)	Peak Power (dBm/50MHz)	Limit (dBm/50MHz)	Margin (dB)	Result
3993.6	-8.62	0	8.62	Pass

Test Result of Maximum Average Emissions

Frequency (MHz)	Average Power (dBm/MHz)	Limit (dBm/MHz)	Margin (dB)	Result
3993.6	-49.712	-41.3	8.412	Pass

A.3 Cessation Time Test Result

Test Site	WZ-AC2	Test Engineer	Tommy Tang
Test Date	2022/03/01 ~ 2022/03/05		

EUT initials the UWB Link (9.76s < 10s)

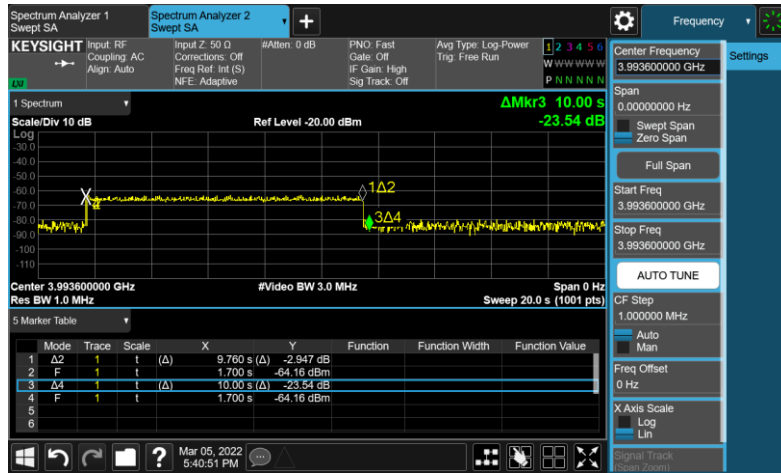

Zoom-in Plot during On-time and Packets Exchanged (Transmit at close to 20ms intervals)

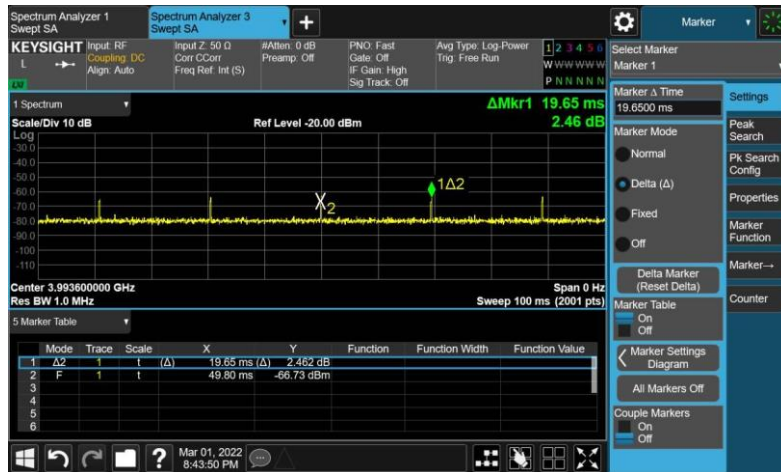

A.4 Radiated Spurious Emission Test Result

Test Site	WZ-AC2	Test Engineer	Tommy Tang
Test Date	2021/12/30		

Frequency Range (MHz)	Measure Level (dBm)	Limit (dBm)	Margin (dB)	Detector	Polarity	Verdict
960 ~ 1610	-84.33	-75.30	9.03	Average	Horizontal	Pass
	-82.32	-75.30	7.02	Average	Vertical	Pass
1610 ~ 1990	-74.93	-63.30	11.63	Average	Horizontal	Pass
	-74.90	-63.30	11.60	Average	Vertical	Pass
1990 ~ 3100	-73.43	-61.30	12.13	Average	Horizontal	Pass
	-73.06	-61.30	11.76	Average	Vertical	Pass
3100 - 10600	-48.95	-41.30	7.65	Average	Horizontal	Pass
	-57.99	-41.30	16.69	Average	Vertical	Pass
Above 10600	-70.67	-61.30	9.37	Average	Horizontal	Pass
	-69.76	-61.30	8.46	Average	Vertical	Pass
1164 ~ 1240	-95.32	-85.30	10.02	Average	Horizontal	Pass
	-95.98	-85.30	10.68	Average	Vertical	Pass
1559 ~ 1610	-97.49	-85.30	12.19	Average	Horizontal	Pass
	-96.05	-85.30	10.75	Average	Vertical	Pass

The Result of Radiated Emission below 1GHz:

Site: WZ-AC2	Time: 2021/12/30
Temperature: 25°C	Humidity: 54%
Limit: FCC_Part15.209_RE(3m)	Engineer: Tommy Tang
Probe: WZ-AC2_VULB9162_0.03-7GHz	Polarity: Horizontal
EUT: Smart Main Module	Power: By Battery
Test Mode: Transmit by UWB at channel 3993.6MHz	

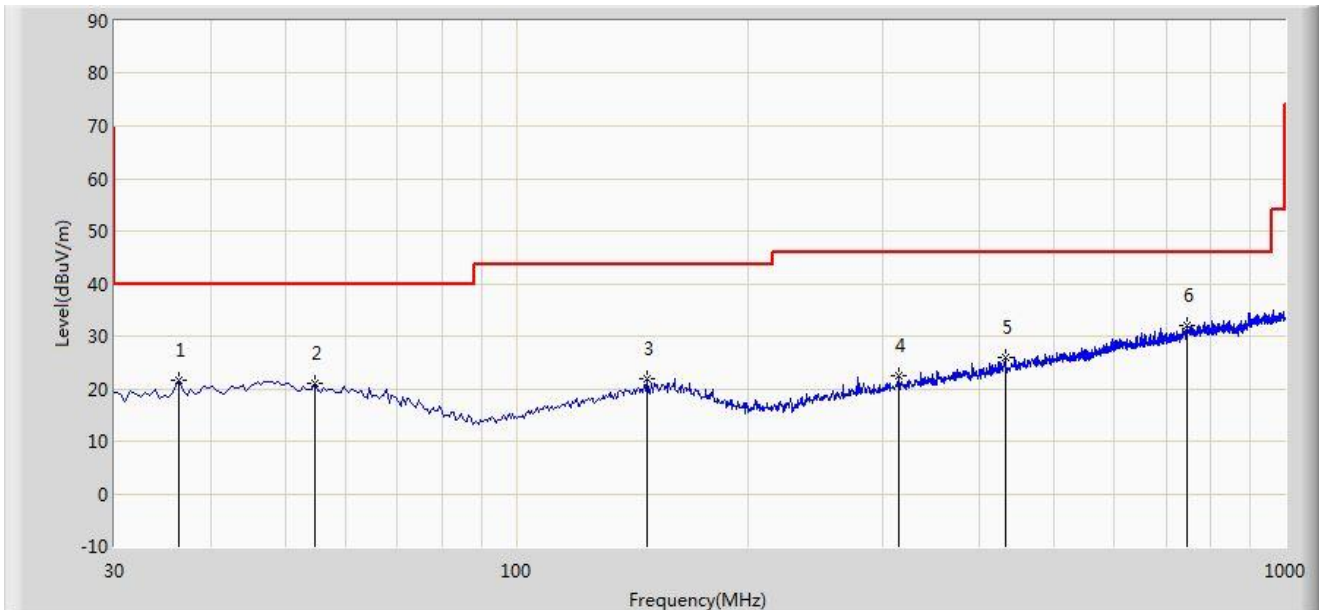

No	Flag	Mark	Frequency (MHz)	Measure Level (dBμV/m)	Reading Level (dBμV)	Margin (dB)	Limit (dBμV/m)	Factor (dB/m)	Type
1			36.305	21.494	4.286	-18.506	40.000	17.208	PK
2			54.735	20.910	2.703	-19.090	40.000	18.207	PK
3			147.855	22.013	4.011	-21.487	43.500	18.002	PK
4			313.725	22.482	3.830	-23.518	46.000	18.652	PK
5			432.065	25.888	4.077	-20.112	46.000	21.811	PK
6		*	744.405	32.088	4.022	-13.912	46.000	28.065	PK

Note 1: Measure Level (dBμV/m) = Reading Level (dBμV) + Factor (dB/m)

Factor (dB/m) = Cable Loss (dB) + Antenna Factor (dB/m)

Note 2: QP measurement was not performed when peak measure level was lower than the QP limit.

Note 3: The amplitude of radiated emissions (frequency range from 9kHz to 30MHz and 18GHz to 34GHz) is that proximity to ambient noise, which also are attenuated more than 20 dB below the permissible value.

Therefore, the data is not presented in the report.

Site: WZ-AC2	Time: 2021/12/30
Temperature: 25°C	Humidity: 54%
Limit: FCC_Part15.209_RE(3m)	Engineer: Tommy Tang
Probe: WZ-AC2_VULB9162_0.03-7GHz	Polarity: Vertical
EUT: Smart Main Module	Power: By Battery
Test Mode: Transmit by UWB at channel 3993.6MHz	

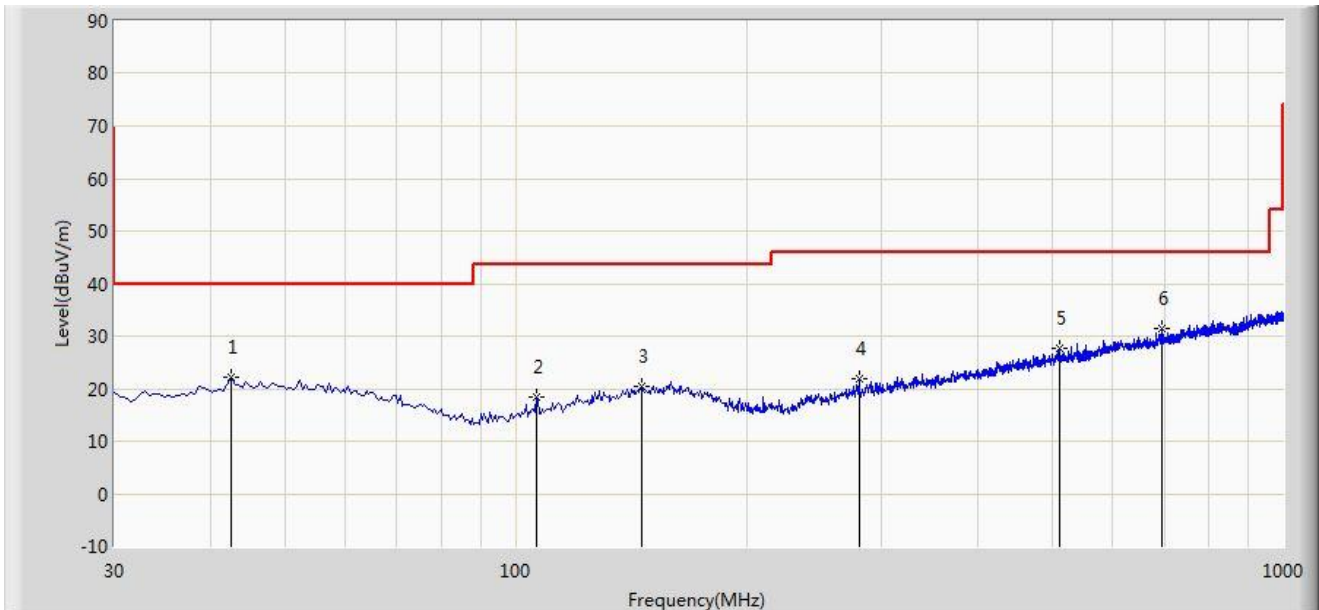

No	Flag	Mark	Frequency (MHz)	Measure Level (dBμV/m)	Reading Level (dBμV)	Margin (dB)	Limit (dBμV/m)	Factor (dB/m)	Type
1			42.610	22.284	4.010	-17.716	40.000	18.274	PK
2			106.630	18.380	4.406	-25.120	43.500	13.974	PK
3			145.915	20.362	2.456	-23.138	43.500	17.906	PK
4			280.260	21.849	4.161	-24.151	46.000	17.688	PK
5			510.635	27.743	4.317	-18.257	46.000	23.426	PK
6		*	694.935	31.458	4.597	-14.542	46.000	26.860	PK

Note 1: Measure Level (dBμV/m) = Reading Level (dBμV) + Factor (dB/m)

Factor (dB/m) = Cable Loss (dB) + Antenna Factor (dB/m)

Note 2: QP measurement was not performed when peak measure level was lower than the QP limit.

Note 3: The amplitude of radiated emissions (frequency range from 9kHz to 30MHz and 18GHz to 35GHz) is that proximity to ambient noise, which also are attenuated more than 20 dB below the permissible value.

Therefore, the data is not presented in the report.

A.5 AC Conducted Emissions Test Result

Site: WZ-SR2	Time: 2022/03/07
Temperature: 18.4°C	Humidity: 39.7%
Limit: FCC_Part15.107_CE_AC Power_Class B	Engineer: Helen Han
Probe: ENV216_101683_Filter Off_E	Polarity: Line
EUT: Smart Shield Main Module	Power: AC 120V/60Hz

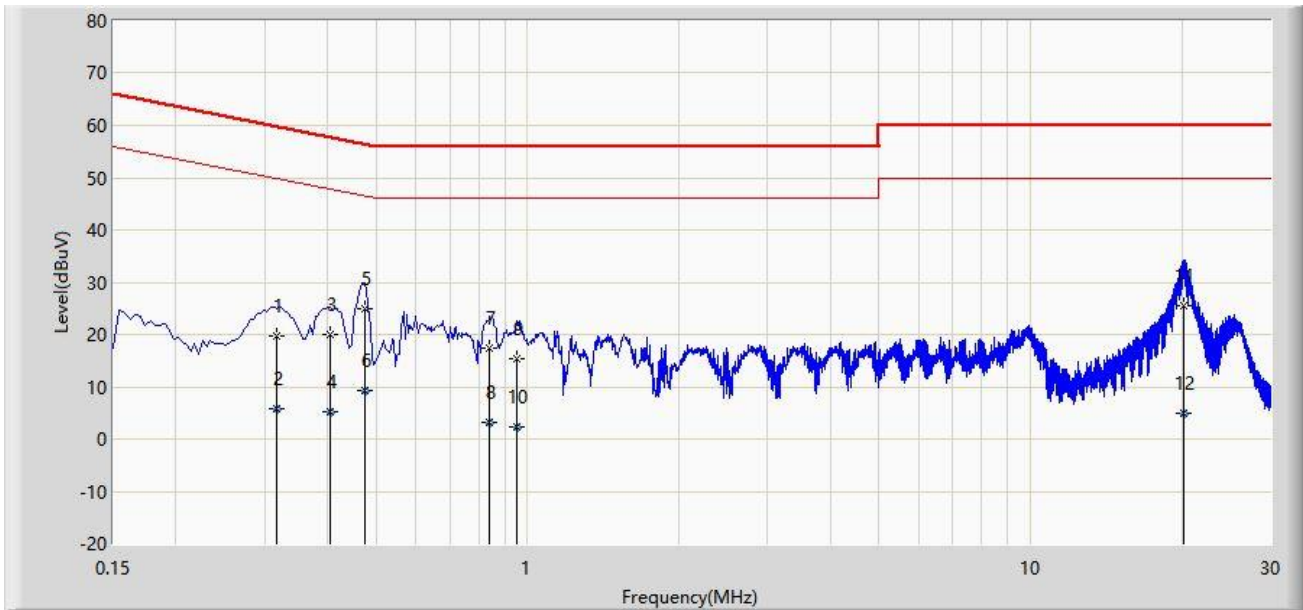

No	Flag	Mark	Frequency (MHz)	Measure Level (dBμV)	Reading Level (dBμV)	Margin (dB)	Limit (dBμV)	Factor (dB)	Type
1			0.318	19.828	9.920	-39.931	59.759	9.908	QP
2			0.318	5.854	-4.053	-43.904	49.759	9.908	AV
3			0.406	19.864	9.951	-37.865	57.730	9.913	QP
4			0.406	5.338	-4.575	-42.391	47.730	9.913	AV
5		*	0.474	24.865	14.947	-31.579	56.444	9.918	QP
6			0.474	9.168	-0.750	-37.275	46.444	9.918	AV
7			0.842	17.298	7.359	-38.702	56.000	9.939	QP
8			0.842	3.309	-6.630	-42.691	46.000	9.939	AV
9			0.950	15.322	5.376	-40.678	56.000	9.946	QP
10			0.950	2.178	-7.769	-43.822	46.000	9.946	AV
11			20.158	25.588	14.107	-34.412	60.000	11.481	QP
12			20.158	4.826	-6.655	-45.174	50.000	11.481	AV

Note: Measure Level (dBμV) = Reading Level (dBμV) + Factor (dB)

Factor (dB) = Cable Loss (dB) + LISN Factor (dB)

Site: WZ-SR2	Time: 2022/03/07
Temperature: 18.4°C	Humidity: 39.7%
Limit: FCC_Part15.107_CE_AC Power_Class B	Engineer: Helen Han
Probe: ENV216_101683_Filter Off_E	Polarity: Neutral
EUT: Smart Shield Main Module	Power: AC 120V/60Hz

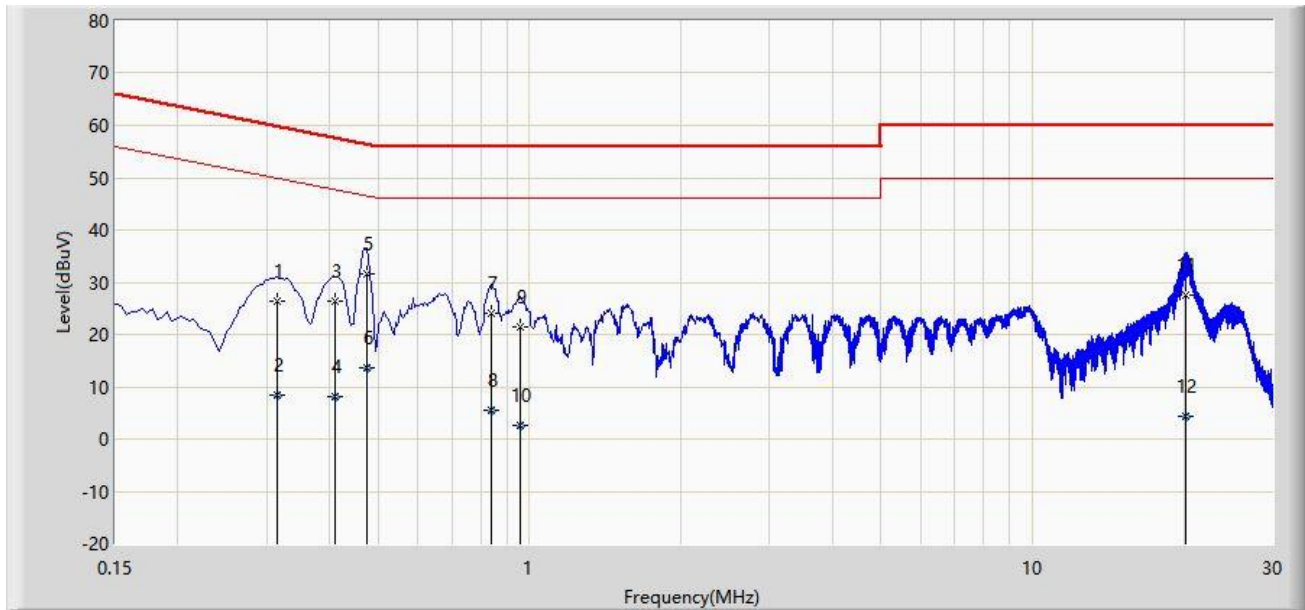

No	Flag	Mark	Frequency (MHz)	Measure Level (dBµV)	Reading Level (dBµV)	Margin (dB)	Limit (dBµV)	Factor (dB)	Type
1			0.314	26.498	16.581	-33.366	59.864	9.917	QP
2			0.314	8.477	-1.440	-41.387	49.864	9.917	AV
3			0.410	26.383	16.459	-31.265	57.648	9.924	QP
4			0.410	8.237	-1.686	-39.411	47.648	9.924	AV
5		*	0.474	31.657	21.729	-24.786	56.444	9.928	QP
6			0.474	13.630	3.702	-32.813	46.444	9.928	AV
7			0.842	23.971	14.017	-32.029	56.000	9.954	QP
8			0.842	5.472	-4.482	-40.528	46.000	9.954	AV
9			0.958	21.563	11.605	-34.437	56.000	9.959	QP
10			0.958	2.727	-7.231	-43.273	46.000	9.959	AV
11			20.158	27.510	15.794	-32.490	60.000	11.716	QP
12			20.158	4.411	-7.305	-45.589	50.000	11.716	AV

Note: Measure Level (dBµV) = Reading Level (dBµV) + Factor (dB)

Factor (dB) = Cable Loss (dB) + LISN Factor (dB)

Appendix B - Test Setup Photograph

Refer to "2111RSU020-UT" file.

Appendix C - EUT Photograph

Refer to "2111RSU020-UE" file.

————— The End —————