

东莞市金赞智能科技有限公司

DONGGUAN KIMCHEN INDUSTRY INTL LIMITED



东莞市金赞智能科技有限公司

产品规格书

PRODUCT SPECIFICATION

客 户:	深圳市倍力奇科技有限公司
CUSTOMER:	_____
客户料号:	3-122DX01010AA-029
CUST P/N:	_____
金赞料号:	_____
K C P/N:	_____
产品型号:	16.9*38*0.08*24P*2P*11TS*43mm
D E S E :	_____
日 期:	2021.12.13
D A T E :	_____
版 本:	A.0
VERSION :	_____

(客户承认受领印) ACCEPTANCE STAMP

拟制 PREPARED BY	跟单员 MERCHANDISER	工程审核 ENGINEER CHECKED BY	制程审核 PRODUCTION CHECKDEDED BY	批准 APPROVED BY
贺亮				

Address: 东莞市石碣镇西沙路 2 号 Tel: 86-076986018114 Fax: 86-076986015646

Http://www.jzcoil.com

文件编号 FileNo: KC-JZ-09-008

东莞市金赞智能科技有限公司

DONGGUAN KIMCHEN INDUSTRY INTL LIMITED

版本变更履历
Version Change History

客户料号:
CUST P/N

3-122DX01010AA-029

金赞型号:
KC DESE

16.9*38*0.08*24P*2P*11TS*43mm

版本 Rev.	变更前 Before Change	变更后内容 DESCRIPTION (Content Or Reason For Changed)	日期 Date	修订者 Revisor
A.0	--	新发行 (Initial Release)	2021/12/13	贺亮

拟制
PREPARED BY

工程审核
ENGINEER CHECKED BY

制程审核
PRODUCTION CHECKED BY

贺亮

胡志军

王海燕

Address: 东莞市石碣镇西沙路 2 号 Tel: 86-076986018114 Fax: 86-076986015646

Http://www.jzcoil.com

文件编号 FileNo: KC-JZ-09-008

东莞市金赞智能科技有限公司

DONGGUAN KIMCHEN INDUSTRY INTL LIMITED

规格内容
Specification客户料号:
CUST P/N

3-122DX01010AA-029

金赞型号:
KC DESE

16.9*38*0.08*24P*2P*11TS*43mm

1. 产品外形尺寸 (OVERALL DIMENSIONS OF PRODUCTS):

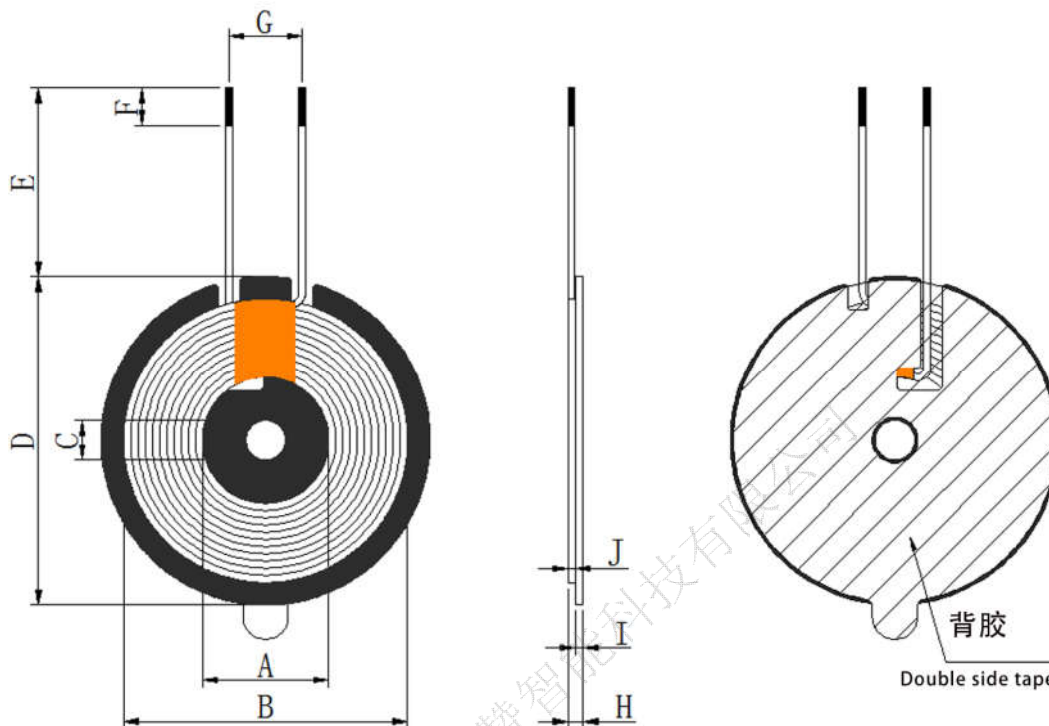

单位(Unit):毫米(mm)

A	B	C	D	E	F	G	H	I	J
16.9±0.5	38±1	5.3±0.5	44±1	43±1	3±1	10±2	1.8MAX	0.5±0.1	0.55±0.05

参考数据 Ref Thickness: 线圈 Coil thickness 0.55mm; 胶水 Epoxy Glue: 0.15mm; 铁氧体 Ferrite core: 0.5mm;
双面胶 Double side tape : 0.08mm; 胶布 Kapton tape: 0.12mm;

PS: H 总厚度不含离形纸 Total thickness not including release paper

圈数 Turns	线径 Wire Dia.	绕线方式 疏/密 Wdg. Type Spred/Close	绕线方向 Wdg. Direction	相交 是/否 Intersect Yes/Not	线圈 正/反贴 Coil Positive/Anti Paste
11turns	0.08*24P*2P 热风绞线 (Litz wire)	密绕 (Close)	逆时针 (Anticlockwise)	是 (Yes)	反贴 (Anti/-Paste)

拟制
PREPARED BY

贺亮

工程审核
ENGINEER CHECKED BY

胡志军

制程审核
PRODUCTION CHECKED BY

高海华

Address: 东莞市石碣镇西沙路 2 号

Tel: 86-076986018114

Fax: 86-076986015646

Http://www.jzcoil.com

文件编号 FileNo: KC-JZ-09-008

东莞市金赞智能科技有限公司

DONGGUAN KIMCHEN INDUSTRY INTL LIMITED

规格内容
Specification客户料号:
CUST P/N

3-122DX01010AA-029

金赞型号:
KC DESE

16.9*38*0.08*24P*2P*11TS*43mm

所有材料要求合格 ROHS 标准 Rohs Standard

2. 电气特性 (ELECTRICAL CHARACTERISTICS):

温度 TEMPERATURE: 25 ± 10 °C, 湿度 RELATIVE HUMIDITY: 65 ± 10%

序号 NO.	项目 ITEM	端子 TERMINAL	标准 SPECIFICATION	测试条件 TEST FREQUENCY	测试仪器 TEST EQUIPMENTS
1	IND	S-F	线圈 Coil: 3.8 uH ± 10%	1kHz/V	LCZ METER 1062
2	IND	S-F	线圈加磁片 Coil+Ferrite: 6.6 uH ± 10%	1kHz/V	LCZ METER 1062
3	DCR	S-F	阻值 Resistance: 20m Ω MAX	1kHz/V	LCZ METER 1062
4	Q 值	S-F	Q 值 Q Value: 35 MIN	100kHz/V	LCZ METER 1062

3. 材料清单 (BILL OF MATERIALS):

序号 number	材料名称 Material name	品名描述 Description	物料代码 Material Code
1	线圈 Copper wire	0.08*24P*2P litz wire	
2	铁氧体 Ferrite core	G44*5.3*0.5H	
3	双面胶 Double side tape	42*5.3*0.08H	
4	金手指胶布 Kapton tape	8mm	
5	胶水 Epoxy glue	JS-E103	

拟制
PREPARED BY

贺亮

工程审核
ENGINEER CHECKED BY

胡志军

制程审核
PRODUCTION CHECKED BY

王海燕

Address: 东莞市石碣镇西沙路 2 号 Tel: 86-076986018114 Fax: 86-076986015646

Http://www.jzcoil.com

文件编号 FileNo: KC-JZ-09-008