

东莞市金赞智能科技有限公司

DONGGUAN KIMCHEN INDUSTRY INTL LIMITED



产品规格书

PRODUCT SPECIFICATION

客 户:	
CUSTOMER:	深圳市倍力奇科技有限公司
客户料号:	
CUST P/N:	3-122DX01010AA-011
金赞料号:	
KC P/N :	
产品型号:	20.5*40*0.08*24P*2P*20TS*9.5
D E S E :	
日 期:	2020.11.19
D A T E :	
版 本:	A.0
VERSION :	

(客户承认受领印) ACCEPTANCE STAMP

拟制 PREPARED BY	跟单员 MERCHANDISER	工程审核 ENGINEER CHECKED BY	制程审核 PRODUCTION CHECKDEDED BY	批准 APPROVED BY
梁少艳				

Add: NO 2 Xisha Road Shijie Donguan 523290 Guangdong China

Tel: 86-769 86018114 Fax: 86-769 86015646

Http://www.jzcoil.com

FileNo: KC-JZ-11-034

东莞市金赞智能科技有限公司

DONGGUAN KIMCHEN INDUSTRY INTL LIMITED

规格内容 Specification		客户料号: CUST P/N	3-122DX01010AA-011
		金赞型号: KC DESE	20.5*40*0.08*24P*2P*20TS*9.5

1. 产品外形尺寸 (OVERALL DIMENSIONS OF PRODUCTS):

拟制 PREPARED BY	工程审核 ENGINEER CHECKED BY	制程审核 PRODUCTION CHECKED BY
梁少艳		

Add: NO 2 Xisha Road Shijie Donguan 523290 Guangdong China

Tel: 86-769 86018114 Fax: 86-769 86015646

Http://www.jzcoil.com

FilNo: KC-JZ-11-027

东莞市金赞智能科技有限公司

DONGGUAN KIMCHEN INDUSTRY INTL LIMITED

规格内容
Specification

客户料号: CUST P/N	3-122DX01010AA-011
金赞型号: KC DESE	20.5*40*0.08*24P*2P*20TS*9.5

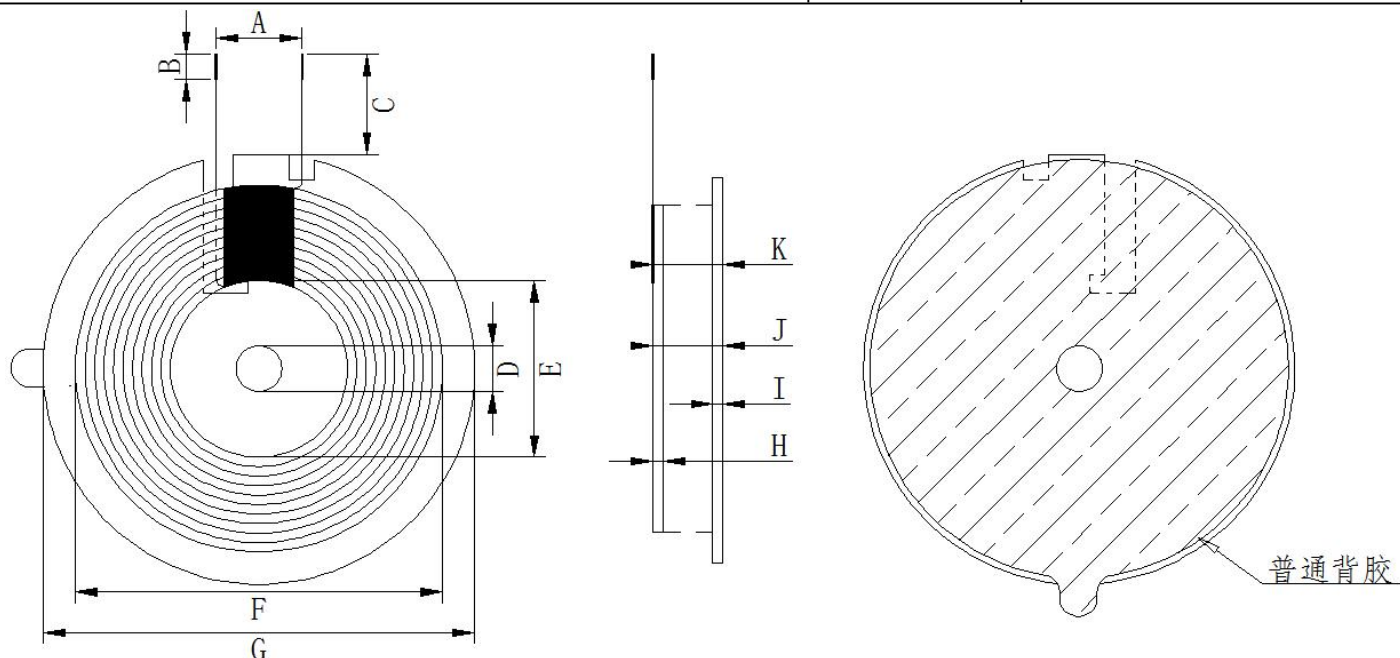

单位(Unit):毫米(mm)

A	B	C	D	E	F	G	H	I	J	K
10±2	3±1	9.5±1	5.3±0.5	20.5±0.5	40±1	44±1	0.55±0.05	0.8±0.1	1.5MAX	1.9MAX

PS: 1. J 不包含 8MM 胶布; 2. K 包含 8MM 胶布; 3. J、K 不含离型纸

圈数 Turns	线径 Wire Dia.	绕线方式 疏/ 密	绕线方向 Wdg. Direction	相交 是/ 否	线圈 正/反贴 Coil
-------------	-----------------	--------------	------------------------	------------	-----------------

拟制 PREPARED BY	工程审核 ENGINEER CHECKED BY	制程审核 PRODUCTION CHECKED BY
梁少艳		

Add: NO 2 Xisha Road Shijie Donguan 523290 Guangdong China

Tel: 86-769 86018114 Fax: 86-769 86015646

Http://www.jzcoil.com

FileNo: KC-JZ-11-027

东莞市金赞智能科技有限公司

DONGGUAN KIMCHEN INDUSTRY INTL LIMITED

规格内容
Specification客户料号:
CUST P/N

3-122DX01010AA-011

金赞型号:
KC DESE

20.5*40*0.08*24P*2P*20TS*9.5

		Wdg. Type Spred/Close		Intersect Yes/Not	Positive/Anti Paste
20TS	0.08*24P*2P 热风绞线 (Hot Air stranded Wire)	密绕 (Close)	逆时针 (Anticlockwise)	是 (Yes)	反贴 (Anti-Paste)

所有材料要求合格 ROHS 标准

2. 电气特性 (ELECTRICAL CHARACTERISTICS):

温度 TEMPERATURE: 25 ± 10 °C, 湿度 RELATIVE HUMIDITY: 65 ± 10%

序号 NO.	项目 ITEM	端子 TERMINAL	标准 SPECIFICATION	测试条件 TEST FREQUENCY	测试仪器 TEST EQUIPMENTS
1	IND	S-F	线圈: 3.6UH ± 10%	1kHz/V	LCZ METER 1062
2	IND	S-F	线圈加磁片: 6.3UH ± 10%	1kHz/V	LCZ METER 1062

3. 材料清单 (BILL OF MATERIALS):

拟制 PREPARED BY	工程审核 ENGINEER CHECKED BY	制程审核 PRODUCTION CHECKED BY
梁少艳		

Add: NO 2 Xisha Road Shijie Donguan 523290 Guangdong China

Tel: 86-769 86018114 Fax: 86-769 86015646

Http://www.jzcoil.com

FilNo: KC-JZ-11-027

东莞市金赞智能科技有限公司

DONGGUAN KIMCHEN INDUSTRY INTL LIMITED

规格内容
Specification客户料号:
CUST P/N

3-122DX01010AA-011

金赞型号:
KC DESE

20.5*40*0.08*24P*2P*20TS*9.5

序号 number	材料名称 Material name	品名描述 Description	物料代码 Material Code
1	线材	0.08*24P 热风绞线	JX-2U-F-0009
2	磁片	G44*5.3*0.8H(双槽带孔)	
3	背胶	42.5*5.3*0.08H(有孔带手撕)	
4	胶布	8MM	

拟制
PREPARED BY

梁少艳

工程审核
ENGINEER CHECKED BY制程审核
PRODUCTION CHECKED BY

Add: NO 2 Xisha Road Shijie Donguan 523290 Guangdong China

Tel: 86-769 86018114 Fax: 86-769 86015646

Http://www.jzcoil.com

FilNo: KC-JZ-11-027