

# 承 認 書

## SPECIFICATION FOR APPROVAL

|                        |  |
|------------------------|--|
| 客 戶:<br>CUSTOMER:      | Shenzhen Chuang Wei Da Technology Co., LTD |
| 客 戶 料 號:<br>CUST P/N:  | Coil Antenna                               |
| 淘 软 料 號:<br>BESOFTP/N: |  |
| 產 品 型 號:<br>DESC:      | Φ19*19x47-12Ts-0.08x105-50mm               |
| 日 期:<br>DATE:          | 2023/07/08                                 |
| 版 本:<br>Version:       | A.0  |

| 擬 制<br>PREPARED BY | 審 核<br>CHECKED BY | 批 准<br>APPROVED BY | 客 戶 承 認<br>CUSTOMER APPROVE |
|--------------------|-------------------|--------------------|-----------------------------|
| 冯伯群                | 苏燕平               | 钱立谋                |                             |

Shenzhen Tao soft electronics Co., LTD

Address: 701, Building 10, District B,  
Shangcun Community, Gongming Street,  
Guangming District, Shenzhen

TEL: 13824883512



# 版本變更履歷

## Version Change History

| 版本<br>Rev. | 變 更 前<br>Before Change | 變 更 後<br>After Change | 更 改 日 期<br>Change Date | 批 准<br>Approved By |
|------------|------------------------|-----------------------|------------------------|--------------------|
| A.0        | 新发行                    | ----                  | 2023/07/08             | 钱立谋                |
|            |                        |                       |                        |                    |
|            |                        |                       |                        |                    |
|            |                        |                       |                        |                    |
|            |                        |                       |                        |                    |
|            |                        |                       |                        |                    |
|            |                        |                       |                        |                    |
|            |                        |                       |                        |                    |
|            |                        |                       |                        |                    |
|            |                        |                       |                        |                    |
|            |                        |                       |                        |                    |
|            |                        |                       |                        |                    |
|            |                        |                       |                        |                    |
|            |                        |                       |                        |                    |
|            |                        |                       |                        |                    |
|            |                        |                       |                        |                    |
|            |                        |                       |                        |                    |
|            |                        |                       |                        |                    |
|            |                        |                       |                        |                    |
|            |                        |                       |                        |                    |
|            |                        |                       |                        |                    |
|            |                        |                       |                        |                    |
|            |                        |                       |                        |                    |
|            |                        |                       |                        |                    |
|            |                        |                       |                        |                    |
|            |                        |                       |                        |                    |
|            |                        |                       |                        |                    |
|            |                        |                       |                        |                    |
|            |                        |                       |                        |                    |
|            |                        |                       |                        |                    |
|            |                        |                       |                        |                    |
|            |                        |                       |                        |                    |
|            |                        |                       |                        |                    |
|            |                        |                       |                        |                    |
|            |                        |                       |                        |                    |
|            |                        |                       |                        |                    |
|            |                        |                       |                        |                    |
|            |                        |                       |                        |                    |
|            |                        |                       |                        |                    |
|            |                        |                       |                        |                    |
|            |                        |                       |                        |                    |
|            |                        |                       |                        |                    |
|            |                        |                       |                        |                    |
|            |                        |                       |                        |                    |
|            |                        |                       |                        |                    |
|            |                        |                       |                        |                    |
|            |                        |                       |                        |                    |

# SPECIFICATION

|               |                                    |                |  |
|---------------|------------------------------------|----------------|--|
| 產品型號:<br>DESC | $\Phi 19*19x47-12Ts-0.08x105-50mm$ | 版本<br>Rev: A 0 | 客戶 CUST:<br>淘软料号 Fine P/N:<br>客户料号 CUST P/N: |
|---------------|------------------------------------|----------------|--|

一、尺寸 DIMENSION:(mm)

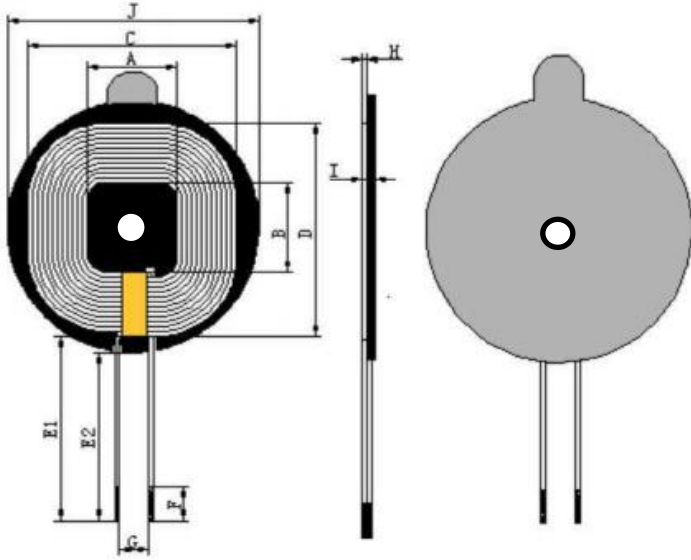

|    |          |
|----|----------|
| A  | 19±0.5   |
| B  | 19±0.5   |
| C  | 47±1     |
| D  | 48±1     |
| E1 | 52±2     |
| E2 | 50±2     |
| F  | 3±1      |
| G  | 8 ref    |
| H  | 1.2 Max  |
| I  | 4 .2 ref |
|    |          |
|    |          |

**注:**

1. 线圈贴磁片，磁片尺寸 50±0.5mm, 内孔5.3mm,厚度为 1.0±0.05mm,开 L 槽。
2. 线圈出线位置缠宽度 8mm ±0.5 高温胶纸。
- 3.磁片背面贴圆形直径 48mm (ref), 内孔6.0mm (ref) 厚度 1.5mmEVA泡棉。

二、原理图 SCHEMATIC DIAGRAM:



三、绕线参数 Winding Specification:

| 序号<br>NO | 端子<br>TERMINAL | 线径<br>WIRE   | 圈数<br>Turns | 绕线方向<br>Winding Direction |
|----------|----------------|--------------|-------------|---------------------------|
| 1        | S F            | 丝包线 0.08*105 | 12Ts        | CCW                       |

四、电气特性 ELECTRICAL CHARACTERISTICS:

温度 TEMPERATURE:25 ±10°C, 湿度 RELATIVE HUMIDITY:65 ±20%

| 序号<br>NO. | 项目<br>ITEM | 端子<br>TERMINAL | 标准<br>SPECIFICATION | 测试条件<br>TEST FREQUENCY | 测试仪器<br>TEST EQUIPMENTS |
|-----------|------------|----------------|---------------------|------------------------|-------------------------|
| 1         | IND.       | S-F            | 6.8uH ±20%单独线圈      | 100KHz/1.0V            | LCZ METER 1062B         |
| 2         | IND.       | S-F            | 10uH ±10%加磁片        | 100KHz/1.0V            | LCZ METER 1062B         |
| 3         | DCR        | S-F            | ≤60m Ω              |                        | LCZ METER 502B          |

|  |  |
|--|--|
| 擬制/日期 PREPARED BY/DATE<br>冯伯群 2023/07/08 | 審核/日期 CHECKED BY/DATE<br>苏燕平2023/07/08 |
|--|--|

## SPECIFICATION

|               |                                     |                |  |
|---------------|-------------------------------------|----------------|--|
| 產品型號:<br>DESC | <b>Φ19*19x47-12Ts-0.08x105-50mm</b> | 版本<br>Rev: A 0 | 客戶 CUST:<br>淘软料号 Fine P/N:<br>客户料号 CUST P/N: |
|---------------|-------------------------------------|----------------|--|

五、包装 PACKONG:

5.1 包装图片 Packing pictures:

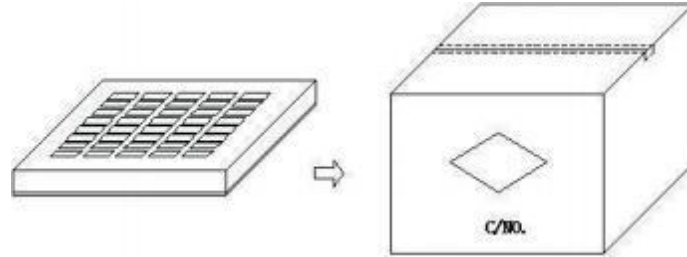

5.2 包装数量及规格 Packing Quantity:

| 项目 Item      | 数量 Quantity | 材料规格 Material |
|--------------|-------------|---------------|
| 盒 Box        | 350 Pcs     | 370*265*55mm  |
| 箱 Big Carton | 1400 Pcs    | 380*270*245mm |

5.3 包装以现有包装盘为参照标准，以实际出货包装为准,如有特需要求可以定制。

The packaging shall be based on the existing packing plate and the actual delivery package shall prevail. If there is any requirement, we can customize it.

六、材料清单 Material list:

| 序号<br>number | 材料名称<br>Material name | 品名描述<br>Description  | 制造商<br>Manufacturer |
|--------------|-----------------------|----------------------|---------------------|
| 1            | 丝包线                   | 丙酮丝包线 0.08*105股      |                     |
| 2            | 无铅锡条                  | 无铅锡条                 |                     |
| 3            | 磁片                    | Φ50*5.3*1 0mm 锰锌硬磁片  |                     |
| 4            | 胶水                    | 201 胶水               |                     |
| 5            | 高温胶纸                  | 8mm 宽高温胶纸            |                     |
| 6            | 带孔EVA                 | 圆形直径 48 mm(ref)EVA泡棉 |                     |

|  |   |
|--|---|
| 擬制/日期 PREPARED BY/DATE<br>冯伯群 2022/04/21 | 審核/日期 CHECKED BY/DATE<br>苏燕平 2022/04/21 |
|--|---|